

GE Fanuc Intelligent Platforms
Motion Solutions Products

Servo Products

Specification Guide, GFH-001F

October 2007



Warnings, Cautions, and Notes as Used in this Publication

Warning

Warning notices are used in this publication to emphasize that hazardous voltages, currents, temperatures, or other conditions that could cause personal injury exist in this equipment or may be associated with its use.

In situations where inattention could cause either personal injury or damage to equipment, a Warning notice is used.

Caution

Caution notices are used where equipment might be damaged if care is not taken.

Note: Notes merely call attention to information that is especially significant to understanding and operating the equipment.

This document is based on information available at the time of its publication. While efforts have been made to be accurate, the information contained herein does not purport to cover all details or variations in hardware or software, nor to provide for every possible contingency in connection with installation, operation, or maintenance. Features may be described herein which are not present in all hardware and software systems. GE Fanuc Automation assumes no obligation of notice to holders of this document with respect to changes subsequently made.

GE Fanuc Automation makes no representation or warranty, expressed, implied, or statutory with respect to, and assumes no responsibility for the accuracy, completeness, sufficiency, or usefulness of the information contained herein. No warranties of merchantability or fitness for purpose shall apply.

The following are trademarks of GE Fanuc Automation North America, Inc.

| | | | |
|-------------------|-------------|-------------|--------------|
| Alarm Master | Genius | ProLoop | Series Six |
| CIMPLICITY | Helpmate | PROMACRO | Series Three |
| CIMPLICITY 90-ADS | Logicmaster | PowerMotion | VersaMax |
| CIMSTAR | Modelmaster | PowerTRAC | VersaPoint |
| Field Control | Motion Mate | Series 90 | VersaPro |
| GEnet | PACSystems | Series Five | VuMaster |
| | Proficy | Series One | Workmaster |

©Copyright 1998—2007 GE Fanuc Automation North America, Inc.
All Rights Reserved.

Contents

| | |
|--|-----------------------|
| Introduction | Introduction-1 |
| Introduction | 0-1 |
| Part I: α Servo System | I-1 |
| Section 1: α SVU Series Servo System Block Diagram | I-2 |
| Section 2: α Series Servo Product Overview | I-3 |
| 2.1 α Series Motors | I-3 |
| 2.2 α Series Motor–Torque Curves | I-4 |
| 2.3 α Series motor holding brake..... | I-5 |
| 2.4 α SVU Series Servo Amplifiers..... | I-6 |
| Section 3: α Series Servo System | I-7 |
| Section 4: α Servo System Options | I-8 |
| 4.1 IP67 Sealing Option on α Series Servo Motors | I-9 |
| 4.2 Absolute Encoder Battery Packs | I-10 |
| Section 5: Installation Guidelines | I-11 |
| 5.1 Motor Environmental Requirements | I-11 |
| 5.2 Servo Amplifier Environmental Requirements | I-11 |
| 5.3 α SVU Series servo amplifier heat Dissipation | I-12 |
| 5.4 α Series Motor Dimensions | I-13 |
| α 6/3000 | I-13 |
| α 6/3000 with Brake, Side View | I-14 |
| α 12/3000, α 22/2000, and α 30/3000, Front View | I-15 |
| α 12/3000, α 22/2000, and α 30/3000, Side View | I-16 |
| α 12/3000, α 22/2000, and α 30/3000 with Brake, Side View..... | I-17 |
| α 40/2000 with Fan, Front And Rear Views | I-18 |
| α 40/2000 with Fan, Top and Side Views | I-19 |
| α 40/2000 with Fan and Brake, Top and Side Views..... | I-20 |
| 5.5 Shaft Loading | I-21 |
| 5.6 α SVU1 Series Amplifier and Panel Cutout Dimensions..... | I-22 |
| α SVU1-80 and SVU1-130 Dimension Drawings..... | I-22 |
| α SVU1-80 and SVU1-130 Panel Cutout Drawings | I-24 |
| 5.7 α SVU Series Switch Settings | I-25 |
| 5.8 Noise Protection | I-26 |
| Separation of Signal and Power Lines | I-26 |
| Grounding | I-26 |
| 5.9 Command Cable Grounding | I-28 |
| 5.10 Selecting a Ground Fault Interrupter..... | I-29 |
| Section 6: α Servo System Power Requirements | I-30 |
| 6.1 Power Line Protection..... | I-30 |
| 6.2 AC Line Filter | I-30 |
| 6.3 Circuit Breaker Selection | I-32 |
| 6.4 Electromagnetic Contactor (MCC) Rating..... | I-32 |
| 6.5 Incoming AC Power | I-33 |
| AC Power Ratings | I-33 |
| 6.6 Discharging Regenerative Energy | I-34 |
| Calculating the Average Regenerative Energy | I-34 |
| Regenerative Discharge Unit Dimensions | I-38 |
| Regenerative Discharge Unit Panel Cutout Dimensions..... | I-40 |
| Section 7: α Servo System Connection | I-41 |
| 7.1 α SVU1 Amplifier Connections | I-41 |
| 7.2 α System Connections..... | I-42 |
| 7.3 α SERIES Servo Connection Diagram | I-44 |
| 7.4 Connection Details..... | I-45 |
| K1—Servo Command Signal Cable (α 6/3000, α 12/3000, α 22/2000, α 30/3000, α 40/2000)..... | I-45 |
| K2—Motor Encoder Feedback Cable (α 6/3000, α 12/3000, α 22/2000, α 30/3000, α 40/2000) | I-47 |
| K3—Three-Phase Servo Power Cable | I-48 |
| K4—Motor Power Cable (α 6/3000)..... | I-48 |
| K4—Motor Power Cable (α 12/3000, α 22/2000) | I-49 |
| K4—Motor Power Cable (α 30/3000, α 40/2000) | I-50 |

| | |
|--|-------------|
| K5—Amplifier Emergency Stop Connection | I-51 |
| K6—Amplifier Control Power Connection | I-51 |
| K7—Separate Regenerative Discharge Unit Power Cable (α 6/3000, α 12/3000, α 22/2000, α 30/3000, α 40/2000) | I-52 |
| K8— Separate Regenerative Discharge Unit Thermal Protection Cable (α 6/3000, α 12/3000, α 22/2000, α 30/3000, α 40/2000) | I-52 |
| K9—Optional Absolute Encoder Battery Cable (α 6/3000, α 12/3000, α 22/2000, α 30/3000, α 40/2000) I-53 | |
| K10—Emergency Stop/Power Enable Cable (α 6/3000, α 12/3000, α 22/2000, α 30/3000, α 40/2000)I-54 | |
| K11—Separate Regenerative Discharge Unit Fan Supply Cable (ZA06B-6089-H711 or ZA06B-6089-H713) | I-55 |
| K12—Motor Brake Power Connection | I-55 |
| K13—Cooling Fan Power Connection (α 40/2000) | I-56 |
| Section 8: α SVU Series Protection and Alarm Functions | I-57 |
| Part II: β Servo System | II-1 |
| Section 9: β Servo System Block Diagram | II-2 |
| Section 10: β Series Servo Product Overview | II-3 |
| 10.1 β Series Motors | II-3 |
| 10.2 β Series Motor Speed–Torque Curves | II-4 |
| 10.3 β Series Motor Holding Brake | II-6 |
| 10.4 β Series Servo Amplifiers | II-8 |
| Section 11: β Series Servo System Specifications | II-9 |
| Section 12: β Servo System Options | II-10 |
| 12.1 Absolute Encoder Battery Packs | II-11 |
| Section 13: Installation Guidelines | II-12 |
| 13.1 Motor Environmental Requirements | II-12 |
| 13.2 Servo Amplifier Environmental Requirements | II-12 |
| 13.3 β servo Amplifier heat dissipation and maintenance | II-13 |
| 13.4 β and β M Series Motor Dimensions | II-14 |
| β 0.5/3000 Motor, Front and Side Views | II-14 |
| β 2/3000, β 3/3000, β 6/2000, and α C12/2000 Motors, Front View | II-15 |
| β 2/3000, β 3/3000, β 6/2000, and α C12/2000 Motors with Brake | II-17 |
| β M0.5/4000, β M1/4000 Motor Front and Side Views | II-18 |
| 13.5 Shaft Loading | II-19 |
| 13.6 β Series Amplifiers Dimensions | II-20 |
| 13.7 Noise Protection | II-21 |
| Separation of Signal and Power Lines | II-21 |
| Grounding | II-21 |
| 13.8 Command Cable Grounding | II-24 |
| 13.9 Selecting a Ground Fault Interrupter | II-25 |
| Section 14: β Servo System Power Requirements | II-26 |
| 14.1 Power Line Protection | II-26 |
| 14.2 AC Line Filter | II-26 |
| 14.3 Circuit Breaker Selection | II-27 |
| 14.4 Electromagnetic Contactor Rating | II-27 |
| 14.5 Incoming AC Power | II-28 |
| AC Power Ratings | II-28 |
| 14.6 Incoming DC Power | II-29 |
| 14.7 Discharging Regenerative Energy | II-29 |
| Calculating the Average Regenerative Energy | II-30 |
| Section 15: β Servo System Connection | II-32 |
| 15.1 System Connections | II-32 |
| 15.2 β Series Connection Diagram | II-35 |
| 15.3 Connection Details | II-36 |
| K1— Servo Command Signal Cable (β 0.5/3000, β 2/3000, β 3/3000, β 6/2000, α C12/2000) | II-36 |
| K2—Motor Encoder Feedback Cable (β 0.5/3000) | II-38 |
| K2—Motor Encoder Feedback Cable (β 2/3000, β 3/3000, β 6/2000) | II-39 |
| K2—Motor Encoder Feedback Cable (α C12/2000) | II-40 |
| K3—Three-Phase Servo Power Cable (user-supplied) | II-41 |
| K4—Motor AC Power Cable (β 0.5/3000) | II-42 |

| | |
|---|--------------|
| K4—Motor AC Power Cable (β 2/3000, β 3/3000, β 6/2000) | II-43 |
| K4—Motor AC Power Cable (α C12/2000) | II-44 |
| K5—Servo Amplifier Emergency Stop Connection | II-45 |
| K7—Regenerative Power Discharge Cable (β 2/3000, β 3/3000, β 6/2000, α C12/2000) K8—Regenerative Power Discharge Thermal Protection Cable | II-46 |
| K9—Absolute Encoder Battery Cable (β 0.5/3000, β 2/3000, β 3/3000, β 6/2000, α C12/2000) | II-47 |
| K10—Emergency Stop/Power Enable Cable (β 0.5/3000, β 2/3000, β 3/3000, β 6/2000, α C12/2000) | II-48 |
| K12—24 VDC Amplifier Power Cable (β 0.5/3000, β 2/3000, β 3/3000, β 6/2000, α C12/2000) | II-48 |
| K13—24 VDC Amplifier Power Daisy Chain Cable (β 0.5/3000, β 2/3000, β 3/3000, β 6/2000, α C12/2000) | II-49 |
| K14—Motor Brake Power Cable (β 2/3000, β 3/3000, β 6/2000, α C12/2000) | II-49 |
| 15.4 β Series Amplifier Protection and Alarm Functions | II-50 |
| Part III: βi and βHVi Series Servo Systems | III-1 |
| Section 16: β i and β HVi Series Servos Overview | III-2 |
| 16.1 β i and β HVi Series Servo Systems | III-2 |
| 16.2 β i Series Servo Amplifier Packages | III-4 |
| Section 17: β i Servo System Options | III-6 |
| Section 18: Servo Motors | III-7 |
| 18.1 Servo Motor Specifications | III-7 |
| 18.2 β is and β HVis Series Motor Speed–Torque Curves | III-9 |
| 18.3 Motor Outline Drawings | III-11 |
| 18.4 β is and β HVis Series Servo Motor Holding Brake | III-16 |
| 18.5 Brake Power Supply Circuit | III-17 |
| 18.6 Motor Connections | III-19 |
| Section 19: β i and β HVi Amplifiers | III-20 |
| 19.1 Amplifier Electrical Specifications | III-20 |
| β i-Series Amplifier Specifications | III-20 |
| β HVi Series Amplifier Specifications | III-20 |
| 19.2 β i & β HVi Series Amplifier Environmental Specifications | III-20 |
| 19.3 β i & β HVi Series Amplifier Status LED and Alarm Functions | III-21 |
| 19.4 Amplifier External Dimensions | III-23 |
| 19.5 Absolute Encoder Battery Options | III-26 |
| Connection Method for Single Amplifiers | III-26 |
| Connection Method for Multiple Amplifiers | III-28 |
| Section 20: Installation Guidelines | III-29 |
| 20.1 β is and β HVis Motor Environmental Requirements | III-29 |
| 20.2 β is & β HVis Servo Amplifier Environmental Requirements | III-30 |
| 20.3 β i and β HVi Amplifier Heat Dissipation and Maintenance Clearance | III-31 |
| Section 21: Heat Dissipation | III-33 |
| Section 22: Noise Protection | III-34 |
| 22.1 Separation of Signal and Power Lines | III-34 |
| 22.2 Grounding | III-34 |
| 22.3 Encoder Feedback Cable Grounding | III-37 |
| Section 23: β i and β HVi Servo System Power Requirements | III-38 |
| 23.1 Power Line Protection | III-38 |
| 23.2 AC Line Filter | III-38 |
| 23.3 Circuit Breaker Selection | III-39 |
| 23.4 Electromagnetic Contactor Rating | III-39 |
| 23.5 Incoming AC power | III-40 |
| AC Power Ratings | III-40 |
| 23.6 Incoming DC Power | III-41 |
| 24 VDC Fuse Locations | III-41 |
| 23.7 Discharging Regenerative Energy | III-42 |
| β SVM1-20i Amplifier Regeneration Options | III-42 |
| β SVM1-40i Amplifier Regeneration Options | III-42 |
| β SVM1-40i, β SVM1-10HVi and β SVM1-20HVi Switch Settings | III-43 |
| Regenerative Discharge Unit Dimensions | III-44 |
| Regenerative Discharge Unit Panel Cutout Dimensions | III-46 |
| Calculating the Average Regenerative Energy | III-47 |
| Section 24: β i and β HVi Series Servo System Connection | III-49 |
| 24.1 Connectors on the Motor Side | III-51 |

| | | |
|---|--|-------------|
| 24.2 | Signal Connectors on the Cable Side (Models $\beta 0.2is$ and $\beta 0.3is$)..... | III-53 |
| 24.3 | Signal Connectors on the Cable Side (models $\beta 0.4is$ to $\beta 22is$ and $\beta 2HVis$ to $\beta 22HVis$)..... | III-54 |
| 24.4 | Power and Brake Connectors on the Cable Side (models $\beta 0.2is$ and $\beta 0.3is$) | III-56 |
| 24.5 | Power and Brake Connectors on the Cable Side (models $\beta 0.4is$ to $\beta 1is$)..... | III-57 |
| 24.6 | Power and Brake Connectors on the Cable Side (models $\beta 2is$, $\beta 2HVis$, $\beta 4is$ and $\beta 4HVis$) | III-58 |
| 24.7 | Power Connectors on the Cable Side (models $\beta 8is$ to $\beta 22is$ and $\beta 8HVis$ to $\beta 22HVis$) | III-59 |
| | Example of connector connection | III-59 |
| | Specifications of plug connectors on the cable side (support for waterproof IP67, TÜV-approved type) | III-60 |
| 24.8 | Brake Connectors on the Cable Side (models $\beta 8is$ to $\beta 22is$ and $\beta 8HVis$ to $\beta 22HVis$) | III-62 |
| 24.9 | Connection to a Conduit Hose | III-63 |
| 24.10 | System Connection Diagram and Cable Reference | III-64 |
| 24.11 | Cable Details | III-67 |
| | FSSB Fiber Optic Servo Command Interface Cable | III-67 |
| | FSSB Cable Specifications | III-67 |
| | FSSB Cable Connections | III-68 |
| | Details of Cable K1- Motor Serial Encoder Feedback..... | III-69 |
| | Details of Cable K2 – AC Power to $\beta SVM1-20i$ Amplifier..... | III-71 |
| | Details of Cable K2 – AC Power to $\beta SVM1-40i$ Amplifier, $\beta SVM1-10HVi$ and $\beta SVM1-20HVi$ | III-72 |
| | Details of Cable K3 – Motor Power to $\beta SVM1-20i$ Amplifier | III-73 |
| | Details of Cable K3 – Motor Power to $\beta SVM1-40i$, $\beta SVM1-10HVi$ and $\beta SVM1-20HVi$ Amplifier | III-74 |
| | Details of Cables K4 and K5 – Regenerative Discharge Resistor..... | III-75 |
| | $\beta SVM1-20i$ | III-75 |
| | $\beta SVM1-40i$ | III-77 |
| | $\beta SVM1-10HVi$ and $\beta SVM1-20HVi$ | III-79 |
| | Details of Cable K6 – 24V, E-Stop and Battery Daisy Chain for Multi-Axis Systems | III-80 |
| | Details of Cable K7 – E-Stop/Power Enable (MCC) | III-81 |
| | Details of Cable K8 – Servo Amplifier Emergency Stop Connection | III-82 |
| | Details of Cable K9 – Optional External Absolute Encoder Battery Connection | III-83 |
| | Details of Cable K10 –External Cooling Fan Connector | III-84 |
| Part IV: αi and αHVi Series Servo Systems..... | | IV-1 |
| | Section 25: αi and αHVi Series Servos Overview | IV-2 |
| | 25.1 αi and αHVi Series Servo Systems..... | IV-2 |
| | 25.2 αi Series Servo Amplifier Packages..... | IV-3 |
| | Section 26: αHVi Servo System Options | IV-4 |
| | Section 27: Servo Motors | IV-5 |
| | 27.1 Servo Motor Specifications | IV-5 |
| | 27.2 αi and $\alpha HVis$ Series Motor Speed–Torque Curves | IV-8 |
| | 27.3 Motor Outline Drawings | IV-10 |
| | αi Motor..... | IV-10 |
| | αHVi Motors | IV-11 |
| | 27.4 Built-in Brake | IV-14 |
| | Brake Connections | IV-14 |
| | Brake Power Supply Circuit | IV-15 |
| | 27.5 Motor Connections..... | IV-17 |
| | 27.6 Cooling Fan | IV-18 |
| | Connecting the Fan Power | IV-18 |
| | Section 28: $\alpha SVM1$ Amplifiers | IV-19 |
| | 28.1 Amplifier Specifications..... | IV-19 |
| | 28.2 αHVi Series Amplifier Status LED and Alarm Functions..... | IV-20 |
| | 28.3 Amplifier External Dimensions | IV-22 |
| | 28.4 Dynamic Braking Module Dimensions | IV-24 |
| | 28.5 Power Supply Dimensions..... | IV-25 |
| | 28.6 Absolute Encoder Battery Options..... | IV-27 |
| | Battery Connection Method for Single Amplifiers..... | IV-27 |
| | Connection Method for Multiple Amplifiers..... | IV-29 |
| | Section 29: Installation Guidelines | IV-30 |
| | 29.1 αi , αHVi and $\alpha HVis$ Motor Environmental Requirements..... | IV-30 |
| | 29.2 αHVi Servo Amplifier Environmental Requirements | IV-31 |
| | Temperature Derating..... | IV-31 |
| | Cabinet Installation | IV-32 |

| | |
|--|-------|
| 29.3 Amplifier Heat Dissipation and Maintenance Clearance | IV-33 |
| Section 30: Heat Dissipation | IV-34 |
| Section 31: Noise Protection | IV-35 |
| 31.1 Grounding | IV-35 |
| 31.2 Separation of Signal and Power Lines | IV-36 |
| 31.3 Cable Clamp and Shield Grounding | IV-37 |
| Terminal processing of the shield sheaths | IV-37 |
| Cable clamp | IV-37 |
| Grounding | IV-37 |
| 31.4 Encoder Feedback Cable Grounding | IV-38 |
| Section 32: α HVi Servo System Power Requirements | IV-40 |
| 32.1 Power Line Protection | IV-40 |
| 32.2 AC Line Filter | IV-40 |
| AC Line Filter Outline Drawings and Specifications | IV-41 |
| 32.3 Circuit Breaker and Magnetic Contactor Selection | IV-42 |
| Sample Configuration for 200V Input Power | IV-43 |
| Sample Configuration for 400V Input Power | IV-44 |
| 32.4 Incoming AC power | IV-45 |
| AC Power Ratings | IV-45 |
| Section 33: α HVi Series Servo System Connection | IV-46 |
| 33.1 Motor Power Connectors | IV-48 |
| 33.2 Encoder Connectors for α i, α HVi and α HVis Motors | IV-49 |
| Crimp Type Connector | IV-49 |
| Solder Type Connector | IV-50 |
| 33.3 Connectors for Power | IV-51 |
| Connector Connection Example | IV-52 |
| Motor Power Connectors (support for waterproof IP67, TUV-approved type) | IV-53 |
| Plug Connectors on the Cable Side (support for waterproof IP67) | IV-54 |
| 33.4 Connectors for the Brake | IV-55 |
| Connector Specifications | IV-55 |
| 33.5 Connectors for the Fan | IV-56 |
| Connector Specifications for α iS 50/3000HV with fan | IV-56 |
| 33.6 Connection to a Conduit Hose | IV-57 |
| 33.7 System Connection Diagram and Cable Reference | IV-58 |
| 33.8 Cable Details | IV-61 |
| Details of Cable K1 – AC Power to PSM-HVi Power Supply | IV-61 |
| Details of Cable K2 - DC Link Bus Bars | IV-62 |
| Details of Cable K4 – Dynamic Brake Module Power (SVM1-180HVi Amplifier Only) | IV-64 |
| Details of Cable K21 – Motor Power to α SVM1-40HVi and α SVM1-80HVi Amplifiers | IV-65 |
| SVM1 Amplifier CZ2 Motor Power Connector | IV-65 |
| Cable Considerations | IV-66 |
| Motor Connector | IV-66 |
| Details of Cable K21 – Motor Power to α SVM1-180HVi Amplifier | IV-66 |
| Details of Cable K22 – Motor Serial Encoder Feedback | IV-67 |
| Details of Cable K24 – Dynamic Brake Module Interlock Signals | IV-68 |
| Details of Cable K25 – Dynamic Brake Driving Coil | IV-69 |
| Details of Cable K26 – Power to Dynamic Brake Module | IV-69 |
| Details of Cable K27 - FSSB Fiber Optic Servo Command Interface Cable | IV-70 |
| FSSB Cable Specifications | IV-70 |
| FSSB Cable Connections | IV-71 |
| Details of Cable K28 | IV-71 |
| Details of Cable K69 – PSM Interface to SVM Amplifiers | IV-72 |
| Details of Cable K70 – Ground Connection | IV-75 |

Introduction

This specification guide provides technical details for the following digital servo systems:

α Series

β Series

β is Series

α i Series

α HVi, β HVi and β i Series servos can be mixed in the same system and/or on the same DSM324i controller module and use the same FSSB fiber optic interface as the β i Series servos.

For feature comparisons and information on related products, refer to the *Motion Solutions Products Catalog*, GFA-483.

Part I, α Series

The α Series amplifiers can communicate with a wide variety of GE Fanuc controllers, including the Power Mate D, Power Mate H, and DSM 300 Series, plus many of the GE Fanuc CNC systems using a Pulse Width Modulated (PWM) interface. The PWM interface uses the standard GE Fanuc digital servo communication protocol.

A motor protection level of IP65 is standard with all α Series motors, and optional IP67 sealing is available on most α Series motors. Torque ratings of 6 to 40 Nm are available on α Series motors.

A 64K absolute encoder is standard on α Series motors. An optional electrically released holding brake is available on all α Series motors.

Additional documentation for α Series:

α Series Servo Motor Descriptions Manual, GFZ-65142E

α Series Servo Amplifier Descriptions Manual, GFZ-65192EN

AC Servo Amplifier Maintenance Manual, GFZ-65005E

α Series Control Motor Maintenance Manual, GFZ-65165E

α Series Control Motor Amplifier Descriptions Manual, GFZ-65162E

Part II, β Series,

The β Series amplifiers can communicate with a wide variety of GE Fanuc controllers, including the Power Mate D, Power Mate H, and DSM 300 Series, plus many of the GE Fanuc CNC systems using a PWM interface.

A motor protection level of IP65 is standard with all β Series motors. Torque ratings of 0.5 to 12 Nm are available on β Series motors.

A 32K counts /revolution absolute mode digital encoder is standard with each β Series servo motor. An optional electrically released holding brake is available on all β Series motors.

The β Series motors feature an improved insulation system on the windings and an overall sealing coating helps protect the motor from the environment.

Additional documentation for β Series:

β Series Servo Motor Descriptions Manual, GFZ-65232EN

β Series Servo Motor Maintenance Manual, GFZ-65235EN

Servo Products Specification Guide

Part III, β is Series

The β i Series amplifiers communicate with the DSM324 controller using the Fanuc Serial Servo Bus (FSSB) fiber optic interface. The FSSB interface uses the standard GE Fanuc servo communication protocol.

A motor protection level of IP65 is standard with β is Series motors. Torque ratings of 0.4 to 22 Nm are available on the β i Series motors.

β is series motors use 64K or 128K absolute encoders. All β is Series servo motors are available with an optional 24VDC holding brake.

- Additional documentation for β i Series and β HVi Series:

AC Servo Motor β is Series Descriptions Manual, GFZ-65302EN

Servo Amplifier β i Series Descriptions Manual, GFZ-65322EN

AC Servo Motor β is Series, AC Spindle Motor β i Series and AC Servo Amplifier β i Series Maintenance Manual, GFZ-65325EN.

Part IV, α i Series

The α HVi series extend the continuous torque range supported by the DSM324i motion controller to 75 Nm. There is relatively little overlap between these servos and the β i-Series servos currently supported by the DMS324i. The α 22/3000HVi and α 22/4000HVis motors have higher rated speeds than the β 22/2000is motor.

Additional documentation for α is Series:

AC Servo Motor α i Series Descriptions Manual, B-65262EN

Servo Amplifier α i Series Descriptions Manual, GFZ-65282EN

Part I:
 α Servo
System

Section 1: α SVU Series Servo System Block Diagram

The following block diagram shows the interconnections of a typical α Series servo system:

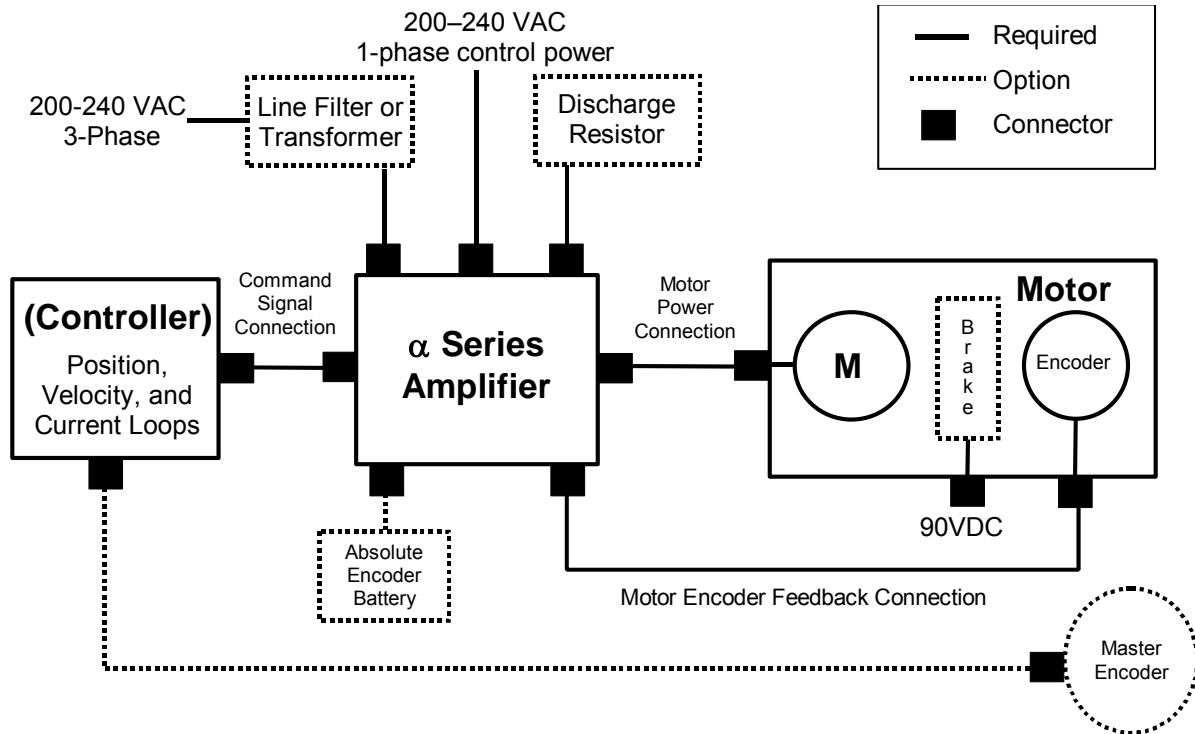

Figure I-1. α SVU Series servo block diagram

NOTE

The 200–240 VAC control power inputs are jumpered to the three-phase bus power inputs (L1C to L1 and L2C to L2) when delivered from the factory. If a separate control power source is desired to maintain alarm status during removal of main bus power, remove the jumper links and connect the separate control power.

Section 2: α Series Servo Product Overview

2.1 α Series Motors

The α Series servo motors include built-in serial encoders with 64K PPR (pulses per revolution) resolution. All α Series motors are available with an optional holding brake, and most are available with an optional IP67 sealing. A fan package is standard on the α 40/2000 servo motor. The servo motors must be used with the designated amplifier package and a GE Fanuc motion controller such as the Motion Mate DSM300 Series.

Table 3HI-1 provides a summary of the α Series servos. See Section 3: for more detailed motor specifications.

Table I-1. α Series Servo Motors

| Motor | Rated Torque | Power Rating | Required Amplifier Kit | Motor Catalog # |
|---------------------------------|--|--------------|------------------------|--|
| α 6/3000 | 6 Nm (53 in-lbs) continuous stall torque; 3000 RPM (max) | 1.4 kW | 80 Amp (IC800APK080) | Motor Only: ZA06B-0128-B575#7008 w/ IP67 Sealing: ZA06B-0128-B575#7076 w/ Brake: ZA06B-0128-B675#7008 w/ IP67 Sealing & Brake: ZA06B-0128-B675#7076 |
| α 12/3000 | 12 Nm (106 in-lbs) continuous stall torque; 3000 RPM (max) | 2.8 kW | 80 Amp (IC800APK080) | Motor Only: ZA06B-0143-B075#7008 w/ IP67 Sealing: ZA06B-0143-B075#7076 w/ Brake: ZA06B-0143-B175#7008 w/ IP67 Sealing & Brake: ZA06B-0143-B175#7076 |
| α 22/2000 | 22 Nm (195 in-lbs) continuous stall torque; 2000 RPM (max) | 3.7 kW | 80 Amp (IC800APK080) | Motor Only: ZA06B-0147-B075#7008 w/ IP67 Sealing: ZA06B-0147-B075#7076 w/ Brake: ZA06B-0147-B175#7008 w/ IP67 Sealing & Brake: ZA06B-0147-B175#7076 |
| α 30/3000 | 30 Nm (265 in-lbs) continuous stall torque; 3000 RPM (max) | 5.2 kW | 130 Amp (IC800APK130) | Motor Only: ZA06B-0153-B075#7008 w/ IP67 Sealing: ZA06B-0153-B075#7076 w/ Brake: ZA06B-0153-B175#7008 w/ IP67 Sealing & Brake: ZA06B-0153-B175#7076 |
| α 40/2000 w/ fan package | 40 Nm (494 in-lbs) continuous stall torque; 2000 RPM (max) | 7.2 kW | 130 Amp (IC800APK130) | Motor w/ Fan Package: ZA06B-0158-B075#7008 w/ Fan Package & Brake: ZA06B-0158-B175#7008 |

2.2 α Series Motor–Torque Curves

The curves shown below illustrate the relationship between the speed of the motor and the output torque. The motor can operate continuously at any combination of speed and torque within the prescribed continuous operating zone. The limit of the continuous operating zone is determined with the motor's ambient temperature at 40°C and its drive current as pure sine wave. Actual operation is limited by the current of the servo drive unit.

α 6/3000

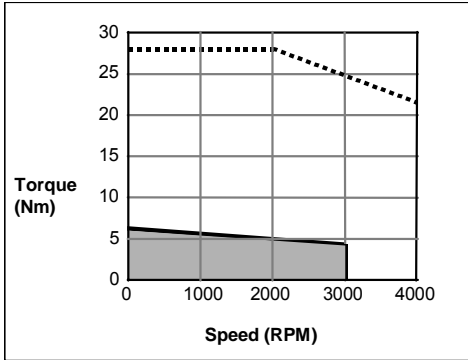

α 12/3000

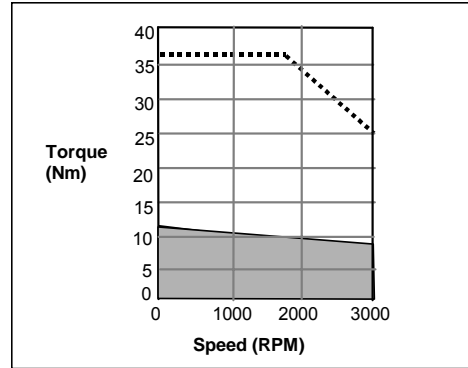

α 22/2000

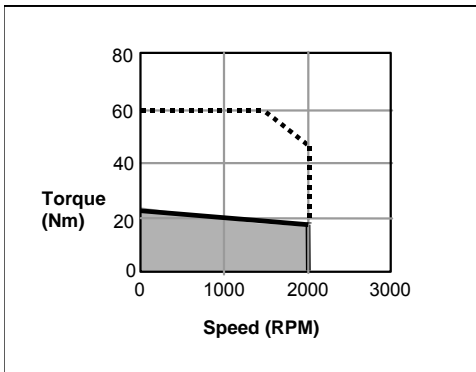

α 30/3000

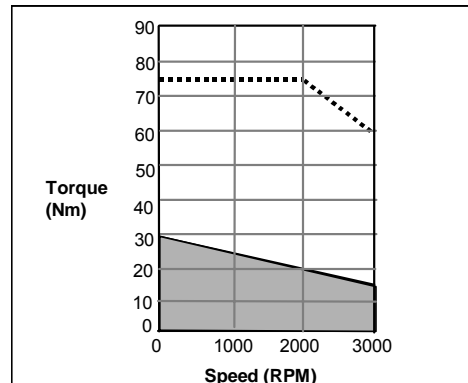

α 40/2000

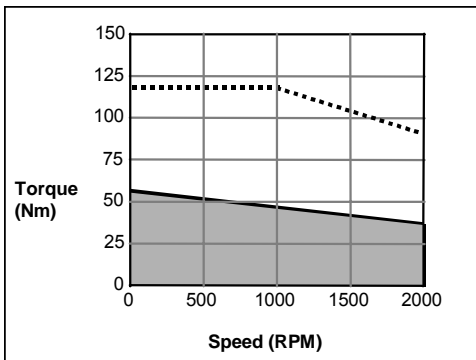

KEY: - - - - = Intermittent operating
 ■ = Continuous operating

Figure I-2. α Series Motor Speed-Torque Curves

2.3 α Series motor holding brake

Any of the servo motors can be ordered with a holding brake. The brake is used to prevent movement on horizontal axes or falling along the vertical axis when the servo motor control is turned off.

Brakes are spring-set and electrically released and are designed for holding stationary loads only. Using the holding brake to stop a moving axis may damage the motor or severely reduce its service life.

The specifications of the built-in brakes are listed in Table 6HI-2:

Table I-2. Brake specifications

| Parameter | SERVO PACKAGE | | | | |
|----------------------------|---|--|--|--|--|
| | α 6/3000 | α 12/2000 | α 22/2000 | α 30/3000 | α 40/2000 |
| Brake torque | 71 in-lb 8 Nm 82 kgf-cm | 310 in-lb 35 Nm 357 kgf-cm | 310 in-lb 35 Nm 357 kgf-cm | 310 in-lb 35 Nm 357 kgf-cm | 310 in-lb 35 Nm 357 kgf-cm |
| Release Response Time | 80 msec | 150 msec | 150 msec | 150 msec | 150 msec |
| Brake Response Time | 40 msec | 20 msec | 20 msec | 20 msec | 20 msec |
| Supply Voltage and Current | 90 VDC ($\pm 10\%$) 0.4 A or less | 90 VDC ($\pm 10\%$) 0.6 A or less | 90 VDC ($\pm 10\%$) 0.6 A or less | 90 VDC ($\pm 10\%$) 0.6 A or less | 90 VDC ($\pm 10\%$) 0.6 A or less |
| Weight Increase | Approx. 5 lb Approx. 2.3 kg | Approx. 13.8 lb Approx. 6.3 kg | Approx. 13.8 lb Approx. 6.3 kg | Approx. 13.8 lb Approx. 6.3 kg | Approx. 22 lb Approx. 10 kg |
| Inertia Increase | 0.00061 in-lb-s ² 0.00007 kg m ² 0.0007 kgf-cm-s ² | 0.0052 in-lb-s ² 0.0006 kg m ² 0.006 kgf-cm-s ² | 0.0052 in-lb-s ² 0.0006 kg m ² 0.006 kgf-cm-s ² | 0.0052 in-lb-s ² 0.0006 kg m ² 0.006 kgf-cm-s ² | 0.0087 in-lb-s ² 0.0010 kg m ² 0.010 kgf-cm-s ² |

An example of a typical **user-supplied** brake power supply is shown below:

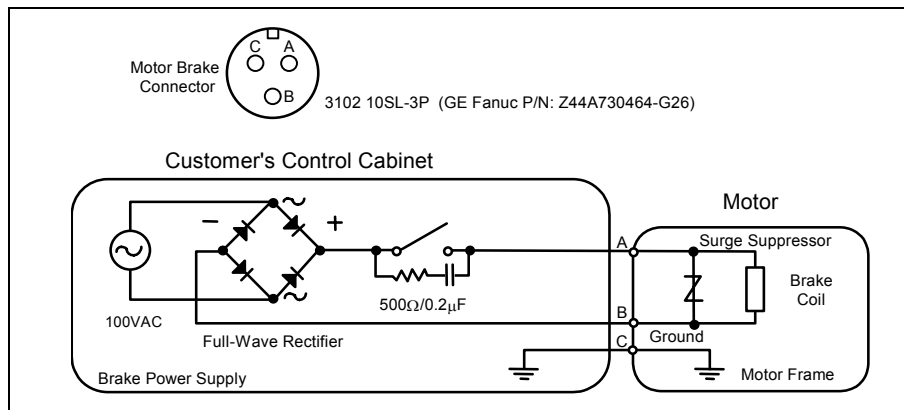

Figure I-3. Typical User-Supplied Brake Power Supply

2.4 α SVU Series Servo Amplifiers

The α SVU Series amplifiers must be matched to the corresponding α Series motor. Because motor characteristics are closely related to amplifier ratings, GE Fanuc restricts the allowable motor/amplifier combinations to those shown in Table 9HI-3 below.

GE Fanuc offers α SVU Series amplifiers either separately, for replacement and spare parts, or as preconfigured packages that include the connectors and spare fuses necessary for most new installations. The catalog numbers for both options and package contents are shown in the following tables.

Table I-3. α SVU Series models

| Motor | Amplifier Model | Amplifier Catalog # | Amplifier Package Catalog # |
|------------------|-----------------|---------------------|-----------------------------|
| α 6/3000 | SVU1-80 | ZA06B-6089-H105 | IC800APK080 |
| α 12/3000 | SVU1-80 | ZA06B-6089-H105 | IC800APK080 |
| α 22/2000 | SVU1-80 | ZA06B-6089-H105 | IC800APK080 |
| α 30/3000 | SVU1-130 | ZA06B-6089-H106 | IC800APK130 |
| α 40/2000 | SVU1-130 | ZA06B-6089-H106 | IC800APK130 |

Table I-4. α SVU Series packages

| Description | Package Contents* | Catalog # |
|---|---|-------------|
| 80 Amp α Series Amplifier Package | <ul style="list-style-type: none"> • 1 SVU1-80 Amp (ZA06B-6093-H105) • 1 Fuse (ZA06B-6089-K250) • 1 External MCC Connector (ZA06B-6089-K201) • 1 E-Stop Connector (ZA02B-0120-K321) | IC800APK080 |
| 130 Amp α Series Amplifier Package | <ul style="list-style-type: none"> • 1 SVU1-130 Amp (ZA06B-6093-H106) • 1 External MCC Connector (ZA06B-6089-K201) • 1 E-Stop Connector (ZA02B-0120-K321) • 2 Fuses (ZA06B-6089-K250) | IC800APK130 |

* If required, amplifier package components can be ordered separately.

Section 3: α Series Servo System

The α Series Servo system consists of a motor and its corresponding amplifier. GE Fanuc offers several servo systems, which are identified in Table 12HI-5 below.

Table I-5. Identification of servo systems

| Parameter (Unit) | SERVO SYSTEM | | | | |
|--|-----------------|------------------|------------------|------------------|-----------------------------|
| | $\alpha 6/3000$ | $\alpha 12/3000$ | $\alpha 22/2000$ | $\alpha 30/3000$ | $\alpha 40/2000$ (w/fan) |
| MOTOR | | | | | |
| Rated output power (kW) | 1.4 | 2.8 | 3.8 | 4.8 | 7.3 |
| Rated torque at stall (Nm) * | 6.0 | 12 | 22 | 30 | 56 |
| Rated torque at stall (in-lb) * | 53 | 106 | 195 | 265 | 495 |
| Rated torque at stall (kgf-cm) * | 61 | 122 | 225 | 306 | 571 |
| Rated output speed (RPM) | 3000 | 3000 | 2000 | 3000 | 2000 |
| Rotor inertia (kg m ²) | 0.002646 | 0.006272 | 0.01176 | 0.01666 | 0.02254 |
| Rotor inertia (in-lb-s ²) | 0.02343 | 0.0555 | 0.1041 | 0.1475 | 0.1996 |
| Rotor inertia (kg-cm-s ²) | 0.027 | 0.064 | 0.12 | 0.17 | 0.23 |
| Continuous RMS current at stall A (rms) | 10.0 | 15.5 | 18.7 | 33.7 | 40.1 |
| Torque constant (Nm/A [rms]) * | 0.60 | 0.77 | 1.17 | 0.89 | 1.40 |
| Torque constant (in-lb/A [rms]) * | 5.3 | 6.8 | 10.4 | 7.9 | 12.4 |
| Torque constant (kgf-cm/A [rms]) * | 6.1 | 7.9 | 12.0 | 9.1 | 14.3 |
| Back EMF constant (V/1000 RPM) * | 21 | 27 | 41 | 31 | 49 |
| Back EMF constant (Vsec/rad) * | 0.20 | 0.26 | 0.39 | 0.30 | 0.47 |
| Armature resistance (Ω) * | 0.18 | 0.17 | 0.140 | 0.046 | 0.080 |
| Mechanical time constant (s) * | 0.004 | 0.005 | 0.004 | 0.003 | 0.003 |
| Thermal time constant (min) | 50 | 60 | 65 | 70 | 30 |
| Static friction (Nm) | 0.3 | 0.8 | 1.2 | 1.8 | 1.8 |
| Static friction (in-lb) | 2.7 | 7.1 | 10.6 | 15.9 | 15.9 |
| Static friction (kgf-cm) | 3 | 8 | 12 | 18 | 18 |
| Maximum allowable current (A [peak]) | 132 | 120 | 160 | 320 | 270 |
| Maximum theoretical torque (Nm) ** | 56 | 66 | 130 | 200 | 270 |
| Maximum theoretical torque (in-lb) ** | 496 | 584 | 1150 | 1770 | 2390 |
| Maximum theoretical torque (kgf-cm) ** | 571 | 670 | 1400 | 2100 | 2800 |
| Weight (kg) | 13 | 18 | 29 | 41 | 55 |
| Weight (lb) | 28.6 | 39.6 | 63.8 | 90.2 | 121 |
| AMPLIFIER | | | | | |
| Amplifier model | SVU1-80 | SVU1-80 | SVU1-80 | SVU1-130 | SVU1-130 |
| Rated output current (rms amps) | 18.7 | 18.7 | 18.7 | 52.2 | 52.2 |
| Current limit (Peak amps) | 80 | 80 | 80 | 130 | 130 |
| Heat loss (watts) | 37.7 | 47.3 | 54 | 70.9 | 80.7 |
| 230 VAC 1 ϕ control power current (A) | 0.13 | 0.13 | 0.13 | 0.26 | 0.26 |
| Weight (kg) | 4.9 | 4.9 | 4.9 | 9.9 | 9.9 |
| Weight (lb) | 10.8 | 10.8 | 10.8 | 21.8 | 21.8 |

* These values are standard values at 20°C with a tolerance of $\pm 10\%$. The speed-torque characteristics vary, depending on the type of software, parameter setting, and input voltage of the digital servo amplifier. (The above figures show average values.) These values may be changed without prior notice.

** Theoretical values. The actual maximum torque is restricted by the current limit values of the drive amplifier.

Section 4: α Servo System Options

Designing a servo control system requires that you understand how the electrical and mechanical aspects of your system interact. GE Fanuc application engineers are available to help you determine your control system requirements.

Table 14HI-6 will help you select which servo options your system requires. Further details for each option are located in the sections indicated.

Table I-6. α Series servo package options

| <i>Servo Option</i> | <i>Consider Selecting When</i> | <i>Catalog #</i> | <i>Section #</i> |
|--------------------------------|---|---|------------------|
| Motor Holding Brake | The system design includes an axis that must hold its position when power is removed. | Motor option (see p. I-3 for motor catalog #) | 2.3 |
| IP67 Sealing | Enables the motor to meet IEC standards for protection from solid objects and water. | Motor option (see p. I-3 for motor catalog #) | 4.1 |
| Absolute Encoder Battery Packs | Avoids having to re-reference the position when power is restored to the control. | IC800ABK001 | 4.2 |
| AC Line Filters | 200—240 VAC is already available to the control cabinet and no transformer is used. Line filters reduce harmonic noise into the servo power supply. | 5.4 kW, 3-phase: ZA81L-0001-0083#3C 10.5 kW, 3-phase: ZA81L-0001-0101#C | 6.2 |
| Prefinished Cables | The cable lengths available from GE Fanuc are appropriate for your application. | Refer to the “Cable Connection” table on p. I-43 | 7.2 |
| External Discharge Resistor | The internal regenerative discharge resistor is insufficient for the application. If required, the regen resistor must be ordered separately. | 16 Ohm 200 Watt: ZA06B-6089-H500 16 Ohm 800 Watt: ZA06B-6089-H713 8 Ohm 800 Watt: ZA06B-6089-H711 | 6.6 |

4.1 IP67 Sealing Option on α Series Servo Motors

Most of the α Series servo motors can be ordered with IP67 Sealing. Motors with the IP67 Sealing meet the IEC standards regarding protection from solid objects and water, as described below:

Standard IP6x: Protection from Solid Objects

- Protected against solid objects greater than 1 mm thickness or diameter
- Dust tight. “No ingress of dust.”

Standard IPx7: Protection from Water

- Protected against dripping water, rate equivalent to 3–5 mm of rain per minute
- Protected against splashing water from any direction
- Protected from harmful damage due to water jets, according to the following test:
 - Spray from all angles of 12.5 liters/minute (3.3 gal/min)
 - Nozzle diameter = 6.3 mm (0.248 in)
 - Pressure = 30 kN/m² (0.3 bar)
 - Distance = 3 m (118 in)
 - Duration = 3 minutes
- Protected from harmful Protected against the effects of immersion, according to the following test:
 - Surface of the water level shall be at least 150 mm (5.9 in) above the highest point of the machine
 - Lowest point of the machine must be at least 1 m (39.4 in) below the surface of the water
 - Duration of the test must be at least 30 minutes
 - Water temperature must not differ from that of the machine by more than 5° C

For more information, refer to CEI/IEC 34–5; 1991 and the GE Fanuc document *Servo and Spindle Motors Exposed to Liquids* (GFK-1046).

4.2 Absolute Encoder Battery Packs

All α Series servo motors feature a built-in serial encoder that can be used in either incremental or absolute mode. To utilize the absolute capability, an optional encoder battery pack (IC800ABK001) must be installed. This pack makes the encoder's position information non-volatile so that the machine does not need to be re-referenced to a home position every time power is restored to the servo system.

The Absolute Encoder Battery Kit (IC800ABK001) contains the following:

- One battery holder (ZA06B-6050-K060)
- Four D-cell, alkaline batteries (ZA98L-0031-0005)

One kit provides battery backup for up to four absolute encoders. A two-meter-long cable (Z44C741863-001) must be ordered separately for each servo axis connected to the battery pack. Kit components cannot be ordered separately.

The battery pack is panel-mounted and requires a cutout in the mounting surface. Mounting dimensions and terminal designations are shown below:

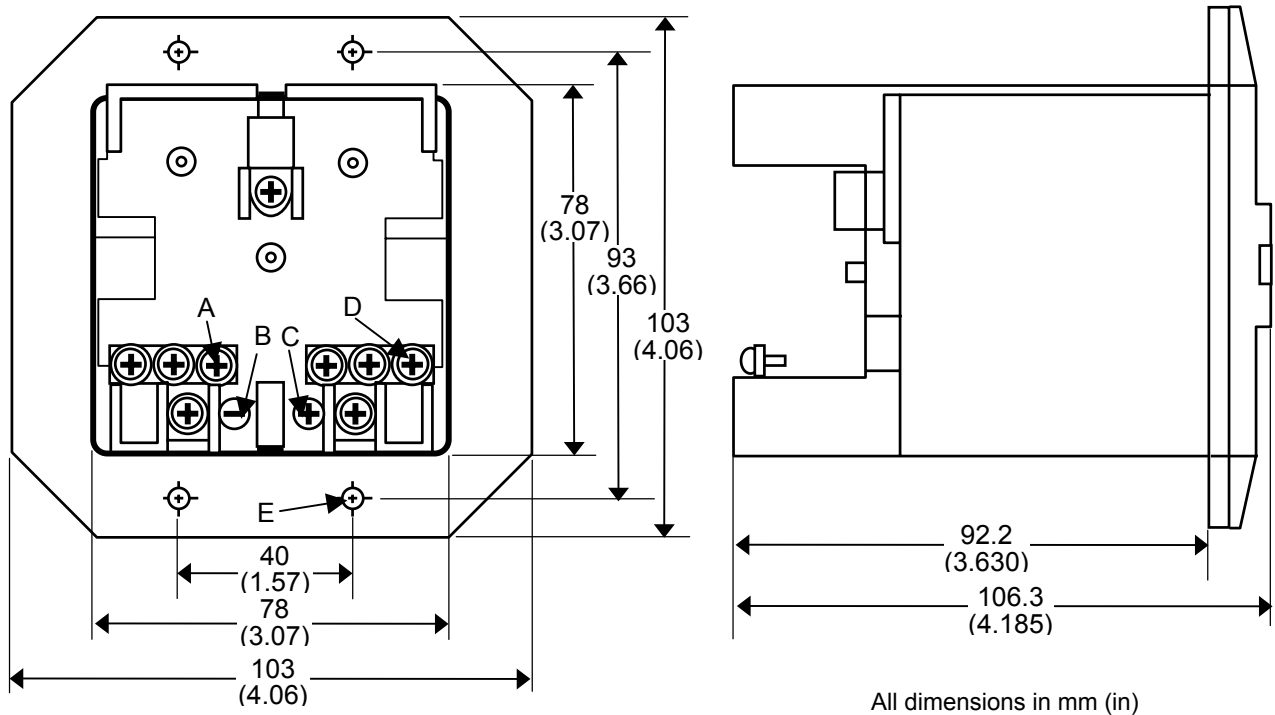

| | |
|---|---|
| A | 3-M3 negative terminal |
| B | Negative terminal indication |
| C | Positive terminal indication |
| D | 3-M3 positive terminal |
| E | 4- \varnothing 4.3 (0.169) mounting holes |

- Note:** Current drain (per encoder) from battery:
- 20 μ A with amplifier power ON
 - 200 μ A with amplifier power OFF

Figure I-4. Absolute encoder battery pack

Section 5: Installation Guidelines

This section includes environmental requirements, motor and amplifier dimension drawings and information on ensuring noise protection and selecting a ground fault interrupter.

5.1 Motor Environmental Requirements

The servo motor must be installed in a location that satisfies the following environmental conditions:

Table I-7. Servo amplifier environmental conditions

| Condition | Description |
|------------------------|--|
| Ambient temperature | The ambient temperature should be -10°C to 40°C. When operating the machine at a temperature higher than 40°C (55°C max), it is necessary to derate the output power so that the motor's temperature rating is not exceeded. |
| Vibration | When installed in a machine, the vibration applied to the motor must not exceed 5G. |
| Altitude | No more than 1,000 m (3,300 ft) above sea level. |
| Drip-Proof Environment | The motors have a drip-proof structure that complies with IP65 of the IEC standard. Optional IP67 Sealing, available on most α Series servo motors, offers further protection from liquids (see Section 4.1 for more details). Nevertheless, to ensure long-term performance, the motor surface should be protected from solvents, lubricants, and fluid spray. A cover should be used when there is a possibility of wetting the motor surface. Also, to prevent fluid from being led to the motor through the cable, put a drip loop in the cable when the motor is mounted. Finally, turn the motor connector sideways or downward as far as possible. If the cable connector will be subjected to moisture, it is recommended that an R class or waterproof plug be used. |

For additional information, see GE Fanuc publication *Servo and Spindle Motors Exposed to Liquids*, GFK-1046.

5.2 Servo Amplifier Environmental Requirements

The servo amplifier must be installed in a location that satisfies the environmental conditions identified in Table 8 below.

Table I-8. Servo amplifier environmental conditions

| Condition | Description |
|-------------------------|--|
| Ambient temperature | 0°C to 55°C (operating). -20°C to 60°C (storage and transportation). |
| Temperature fluctuation | Within 1.1°C/min. |
| Humidity | 30% to 95% RH (no condensation). |
| Altitude | No more than 1000 m (3,300 ft) above sea level. |
| Vibration | No more than 0.5 G during operation. |
| Atmosphere | The circuitry and heat sink must not be exposed to any corrosive and conductive vapor or liquid. |

The amplifier must be installed in a cabinet that protects it from contaminants such as dust, coolant, organic solvents, acid, corrosive gas, and salt. Adequate protection must also be provided for applications where the amplifier could be exposed to radiation, such as microwave, ultraviolet, laser light, or x-rays.

Servo Products Specification Guide

To adequately protect the amplifier, you must ensure that:

- Contaminants such as dust and coolant, cannot enter through the air inlet or outlet.
- The flow of cooling air is not obstructed.
- The amplifier can be accessed for inspection.
- The amplifier can be disassembled for maintenance and later reinstalled.
- There is sufficient separation between the power and signal lines to avoid interference. Noise protection should be provided.

5.3 α SVU Series servo amplifier heat Dissipation

To determine the heat generated by an α Series SVU amplifier with a particular motor, use the table that follows. The α SVU Series amplifiers are mounted with their heat sink extending through a panel cut out in the control enclosure. This design eliminates most of the heat dissipation inside the control cabinet.

Table I-9. Servo amplifier heat dissipation

| <i>Motor Model</i> | <i>Amplifier Model</i> | <i>Total Dissipation</i> | <i>Dissipation Inside Cabinet</i> |
|-------------------------|------------------------|--------------------------|-----------------------------------|
| α 6/3000 | α SVU1-80 | 73 W | 38 W |
| α 12/3000 | α SVU1-80 | 106 W | 47 W |
| α 22/2000 | α SVU1-80 | 127 W | 54 W |
| α 30/3000 | α SVU1-130 | 228 W | 71 W |
| α 40/2000 w/ Fan | α SVU1-130 | 276 W | 81 W |

The following notes apply to the heat values:

- The heat dissipation values are worst case values when motors are run at their continuous output ratings.
- If the heat sink of the amplifier is installed outside the cabinet or if a separate regenerative resistor is installed outside the cabinet, it is unnecessary to add the heat generated by the regenerative resistor to the total heat generated by the cabinet. If the heat sink of a built-in or separate regenerative resistor is installed inside the cabinet, it is necessary to add the heat generated by the regenerative resistor to the heat generated by the cabinet. See Section 6.6 for more information.

5.4 α Series Motor Dimensions

$\alpha 6/3000$

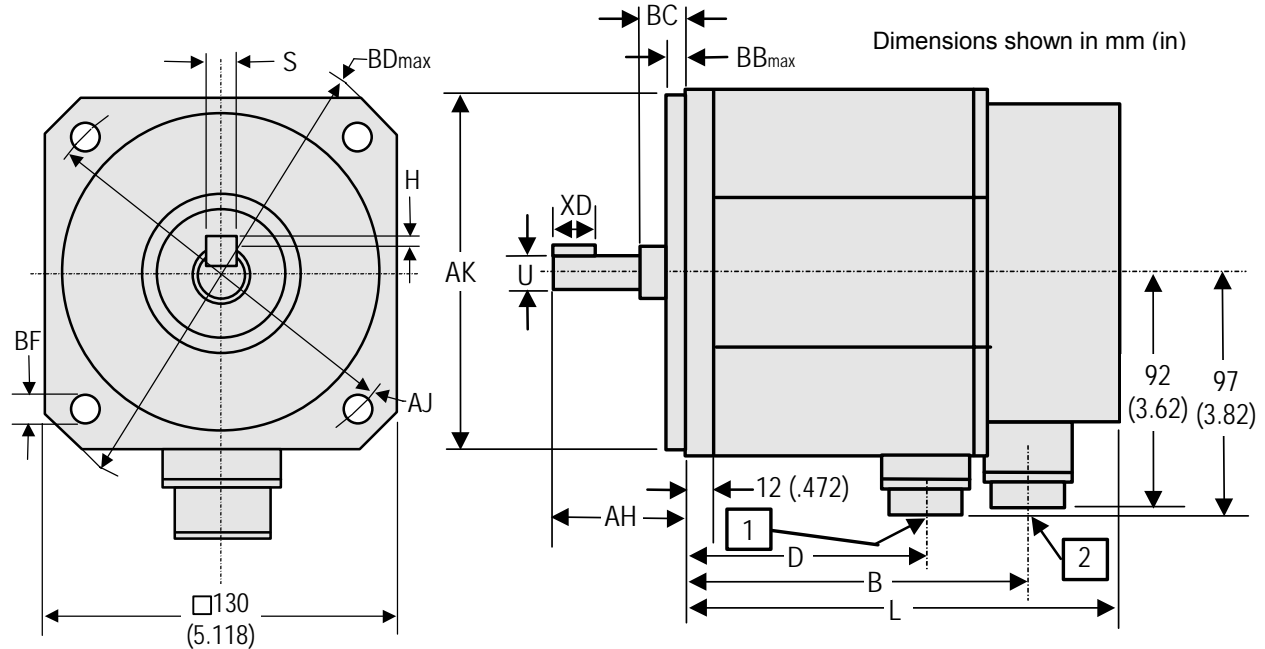

| Dim. | MOTOR $\alpha 6/3000$ |
|----------|--|
| S | $6^{+0}_{-0.030}$ mm (0.2362/0.235 in) |
| H | $2.5^{+0}_{-0.013}$ (0.0984/0.0933) |
| BD | 165 (6.496) |
| AJ (dia) | 145 (5.709) |
| BF (dia) | 9 (0.354) |

| Dim. | MOTOR $\alpha 6/3000$ |
|------|------------------------------------|
| BB | 6 mm (.236 in) |
| XD | 36 (1.417) |
| AK | $110^{+0}_{-0.035}$ (4.331/4.329) |
| U | $19^{+0}_{-0.013}$ (0.7480/0.7475) |
| BC | 15 ± 0.5 (0.610/0.571) |
| AH | 55 (2.165) |
| D | 176 (6.93) |
| B | 221 (8.70) |
| L | 259 (10.20) |

| Connector | Description |
|-----------|----------------------------------|
| 1 | Motor AC Power Connector |
| 2 | Motor Encoder Feedback Connector |

NOTES

1. See the α Connection section (0) for more information about motor cables.
2. Shaft diameter runout = 0.02 mm max (0.00079 in).
3. Flange surface runout = 0.06 mm max (0.00236 in).
4. Rabbet diameter eccentricity = 0.02 mm max (0.00079 in).
5. Maximum radial load for output shaft is 70 kgf (31.8 lb).

Figure I-5. $\alpha 6/3000$ motor, front and side views

α6/3000 with Brake, Side View

(Front view same as α6/3000 without brake)

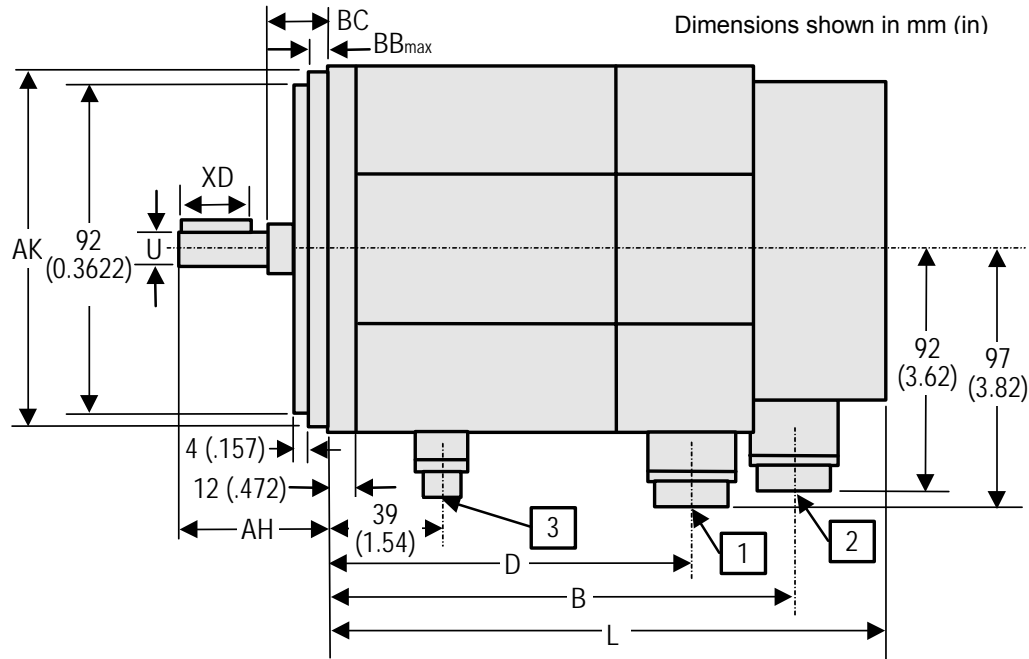

| Dim. | MOTOR |
|------|--|
| | α6/3000 w/ brake |
| BB | 6 mm (0.236 in) |
| XD | 36 (1.917) |
| AK | 110 ⁺⁰ _{-0.035} (4.331/4.329) |
| U | 19 ⁺⁰ _{-0.013} (0.7480/0.7475) |
| BC | 221 (8.70) |
| AH | 55 (2.165) |
| D | 225 (8.858) |
| B | 270 (10.63) |
| L | 309 (12.17) |

| Connector | Description |
|-----------|----------------------------------|
| 1 | Motor AC Power Connector |
| 2 | Motor Encoder Feedback Connector |
| 3 | Brake Connector |

NOTES

1. See the α Connection section (0) for more information about motor cables.
2. Shaft diameter runout = 0.02 mm max (0.00079 in).
3. Flange surface runout = 0.06 mm max (0.00236 in).
4. Rabbet diameter eccentricity = 0.04 mm max (0.00157 in).
5. Maximum radial load for output shaft is 70 kgf (31.8 lb).

Figure I-6. α 6/3000 motor with brake, side view

α12/3000, α22/2000, and α30/3000, Front View

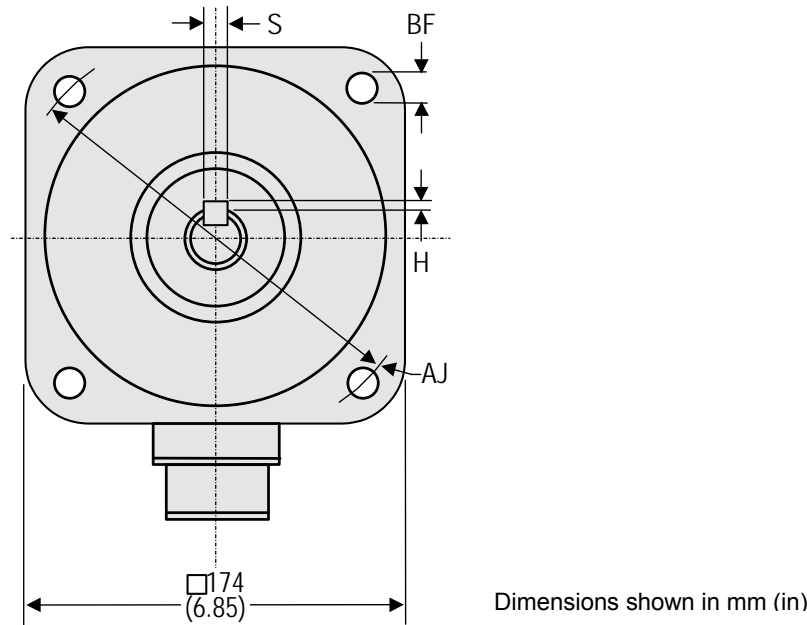

| Dim. | MOTOR | | |
|------|--|--|--|
| | α12/2000 | α22/2000 | α30/3000 |
| S | 10 ⁺⁰ _{-0.036} mm (0.3937/0.3923 in) | 10 ⁺⁰ _{-0.036} mm (0.3937/0.3923 in) | 10 ⁺⁰ _{-0.036} mm (0.3937/0.3923 in) |
| H | 3 ⁺⁰ _{-0.30} (0.1181/0.1063) | 3 ⁺⁰ _{-0.30} (0.1181/0.1063) | 3 ⁺⁰ _{-0.30} (0.1181/0.1063) |
| BF | 13.5 (0.532) | 13.5 (0.532) | 13.5 (0.532) |
| AJ | 200 (7.874) | 200 (7.874) | 200 (7.874) |

NOTES FOR ALL VIEWS (see page 16 for side view and page 17 for side view with brake)

1. See the α Connection section (Section 7.2) for more information about motor cables.
2. Shaft diameter runout = 0.05 mm max (0.00197 in).
3. Flange surface runout = 0.10 mm max (0.00394 in).
4. Rabbet diameter eccentricity = 0.07 mm (0.00276 in).
5. Maximum radial load for output shaft is 450 kgf (204 lb).
6. Taps for eyebolts are M8 by 15 mm (.591 in) deep; eyebolts are not attached.

Figure I-7. α 12/3000, α22/2000, and α30/3000 motors, front view

α12/3000, α22/2000, and α30/3000, Side View

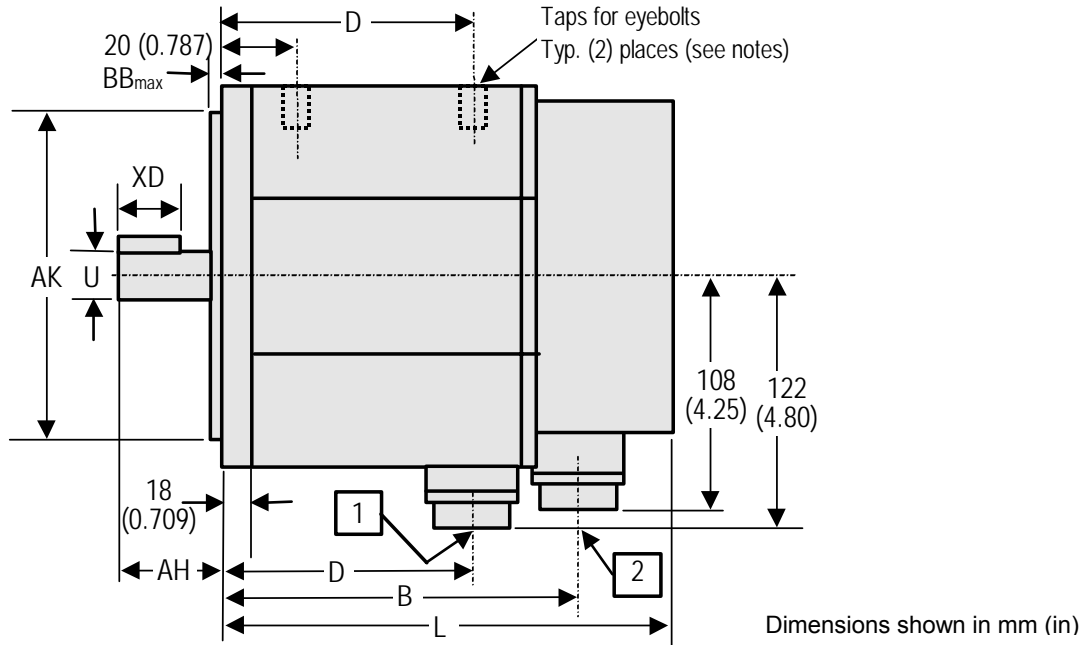

| Dimen. | MOTOR | | |
|--------|--|--|--|
| | α12/2000 | α22/2000 | α30/3000 |
| BB | 3.2 mm (0.126 in) | 3.2 mm (0.126 in) | 3.2 mm (0.126 in) |
| XD | 70 (2.756) | 70 (2.756) | 70 (2.756) |
| AK | 114.3 ⁺⁰ _{-0.025} (4.50/4.499) | 114.3 ⁺⁰ _{-0.025} (4.50/4.499) | 114.3 ⁺⁰ _{-0.025} (4.50/4.499) |
| U | 35 ^{+0.01} ₋₀ (1.3784/1.3779) | 35 ^{+0.01} ₋₀ (1.3784/1.3779) | 35 ^{+0.01} ₋₀ (1.3784/1.3779) |
| AH | 79 (3.11) | 79 (3.11) | 79 (3.11) |
| D | 166 (6.535) | 240 (9.449) | 314 (12.362) |
| B | 215 (8.465) | 289 (11.378) | 363 (14.291) |
| L | 240 (9.45) | 314 (12.36) | 388 (15.28) |

| Connector | Description |
|-----------|----------------------------------|
| 1 | Motor AC Power Connector |
| 2 | Motor Encoder Feedback Connector |

Figure I-8. α 12/3000, α22/2000, and α30/3000 motors, side view

Servo Products Specification Guide

α 12/3000, α 22/2000, and α 30/3000 with Brake, Side View

(Front view same as α 12/3000, α 22/2000, and α 30/3000 without brake; see also Notes on page 15)

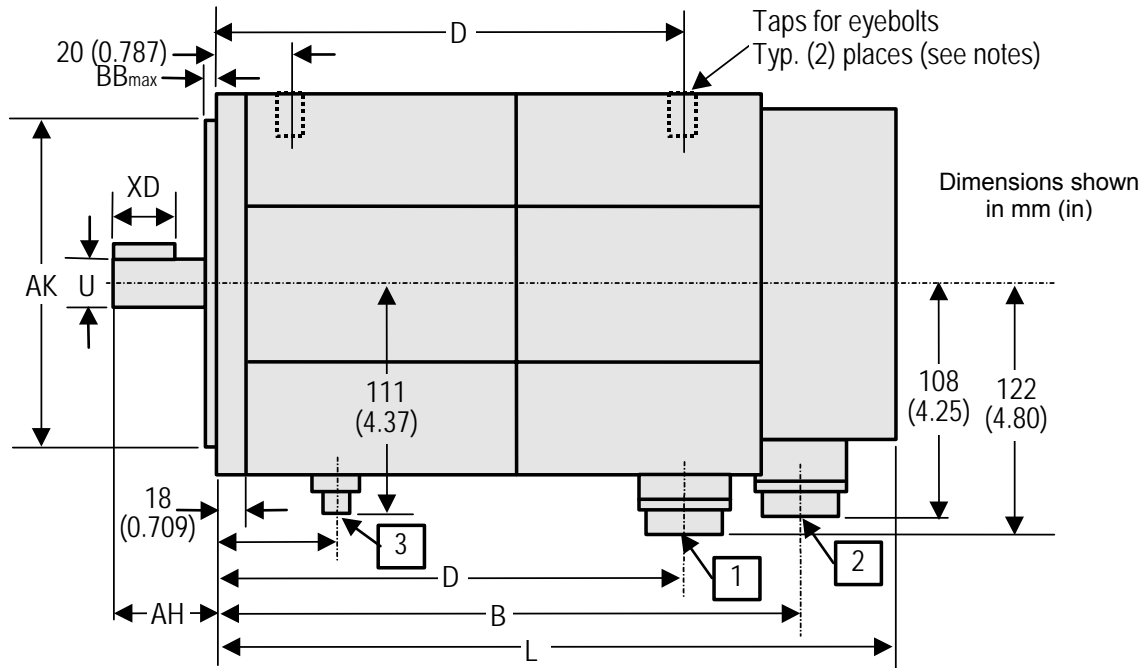

| Dimension | MOTOR | | |
|-----------|--|--|--|
| | α 12/2000 w/brake | α 22/2000 w/brake | α 30/3000 w/brake |
| BB | 3.2 mm (0.126 in) | 3.2 mm (0.126 in) | 3.2 mm (0.126 in) |
| XD | 70 (2.756) | 70 (2.756) | 70 (2.756) |
| AK | 114.3 ⁺⁰ _{-0.025} (4.50/4.499) | 114.3 ⁺⁰ _{-0.025} (4.50/4.499) | 114.3 ⁺⁰ _{-0.025} (4.50/4.499) |
| U | 35 ^{+0.01} ₋₀ (1.3784/1.3779) | 35 ^{+0.01} ₋₀ (1.3784/1.3779) | 35 ^{+0.01} ₋₀ (1.3784/1.3779) |
| AH | 79 (3.11) | 79 (3.11) | 79 (3.11) |
| D | 238 (9.37) | 312 (12.28) | 386 (15.20) |
| B | 287 (11.30) | 361 (14.21) | 435 (17.13) |
| L | 312 (12.28) | 386 (15.20) | 460 (18.11) |

| Connector | Description |
|-----------|----------------------------------|
| 1 | Motor AC Power Connector |
| 2 | Motor Encoder Feedback Connector |
| 3 | Brake Connector |

Figure I-9. α 12/3000, α 22/2000, and α 30/3000 motors with brake, side view

α40/2000 with Fan, Front And Rear Views

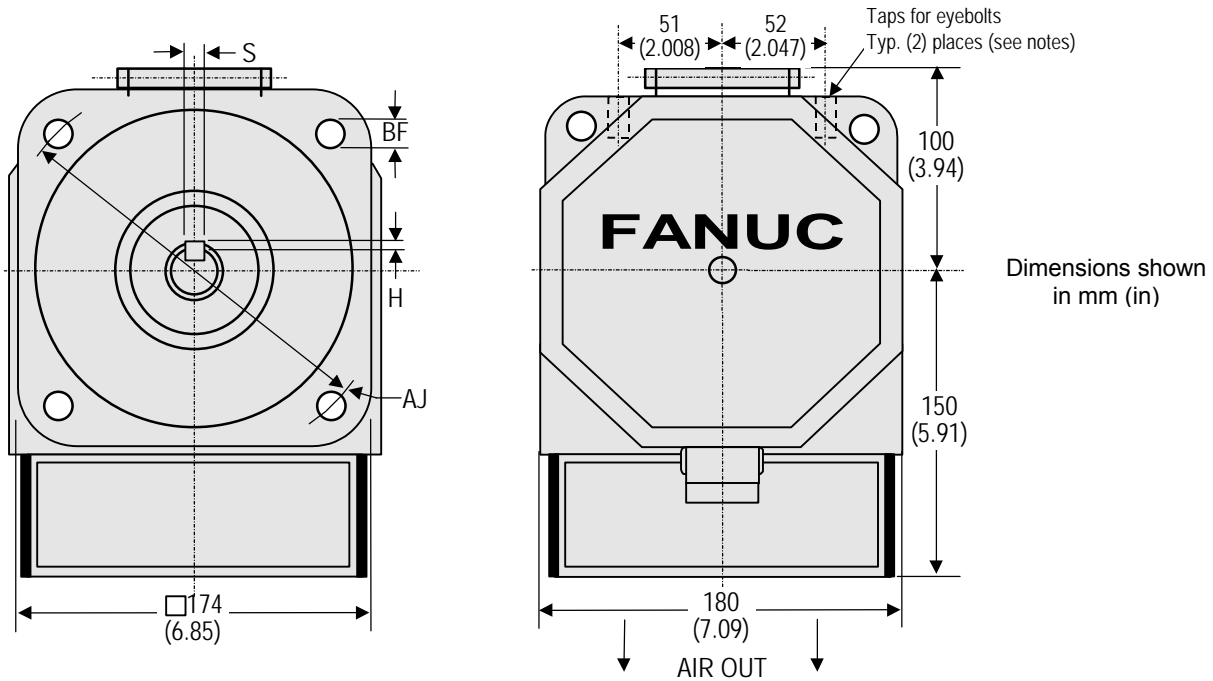

| Dim. | MOTOR |
|-----------|--|
| | α40/2000 w/fan |
| S | 10 ⁺⁰ _{-0.036} mm (0.3937/0.3923 in) |
| H | 3 ⁺⁰ _{-0.30} (0.1181/0.1063) |
| BF (dia.) | 13.5 mm (0.531 in) |
| AJ (dia.) | 200 (7.874) |

NOTES FOR ALL VIEWS (see pages 19 and 20 for top and side views)

1. See Section 7.2 for more information about motor cables.
2. Shaft diameter runout = 0.05 mm max (0.00197 in).
3. Flange surface runout = 10.10 max (0.00394 in).
4. Maximum radial load for output shaft is 450 kgf (990 lb).
5. Taps for eyebolts are M8 by 15 mm (.591 in) deep; eyebolts are not attached.
6. Rabbet diameter eccentricity = 0.07 mm max (0.00276 in).
7. Direction of air flow is downward only.

Figure I-10. α 40/2000 with fan, front and rear views

Servo Products Specification Guide

α 40/2000 with Fan, Top and Side Views

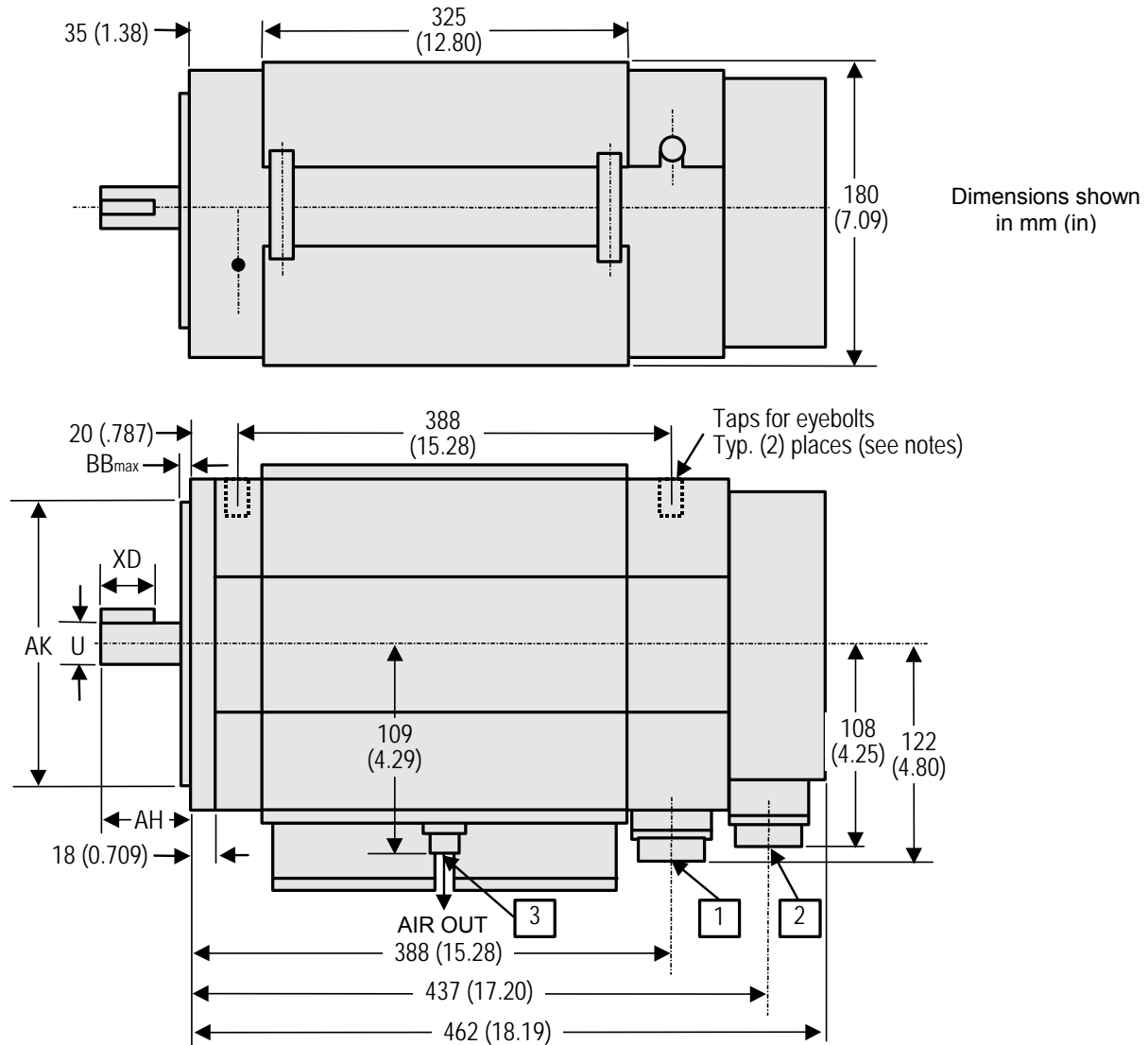

| Dim. | MOTOR |
|------|------------------------------------|
| | α 40/2000 w/fan |
| BB | 3.2 mm (0.126 mm) |
| XD | 70 (2.756) |
| AK | $114.3^{+0}_{-0.025}$ (4.50/4.499) |
| U | $35^{+0.01}_{-0}$ (1.3784/1.3779) |
| AH | 79 (3.11) |

| Connector | Description |
|-----------|----------------------------------|
| 1 | Motor AC Power Connector |
| 2 | Motor Encoder Feedback Connector |
| 3 | Fan Connector |

Figure I-11. α 40/2000 motor with fan, top and side views

α40/2000 with Fan and Brake, Top and Side Views

(Front and rear views same as α40/2000 with fan and without brake)

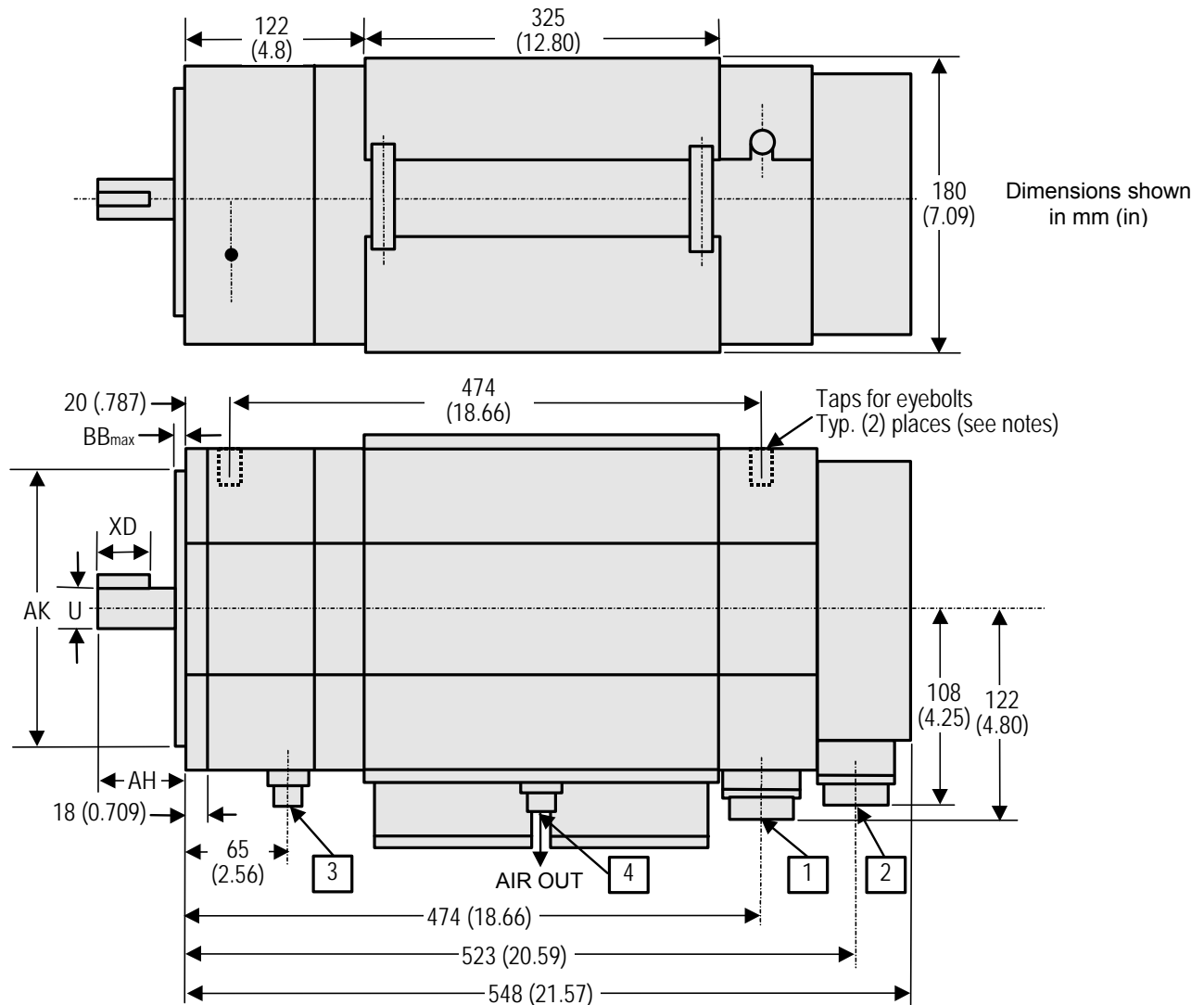

| Dim. | MOTOR |
|------|--|
| | α40/2000 w/fan |
| BB | 3.2 mm (0.126 in) |
| XD | 70 (2.756) |
| AK | 114.3 ⁺⁰ _{-0.025} (4.50/4.499) |
| U | 35 ^{+0.01} ₋₀ (1.3784/1.3779) |
| AH | 79 (3.11) |

| Connector | Description |
|-----------|----------------------------------|
| 1 | Motor AC Power Connector |
| 2 | Motor Encoder Feedback Connector |
| 3 | Brake Connector |
| 4 | Fan Connector |

Figure I-12. α 40/2000 motor with fan and brake, top and side views

5.5 Shaft Loading

The allowable load of the motor shaft is as follows:

Table I-10. Allowable motor shaft load

| <i>Motor Model</i> | <i>Radial Load</i> | <i>Axial Load</i> | <i>Front Bearing Type</i> |
|--|--------------------|-------------------|---------------------------|
| α 6/3000 | 70 kg (31.8 lb) | 20 kg (9.1 lb) | 6205 |
| α 12/3000, α 22/2000, α 30/3000, α 40/2000 w/ fan | 450 kg (204 lb) | 135 kg (61.4 lb) | 6208 |

NOTES:

- The allowable radial load is the value when a load is applied to the shaft end. It indicates the total continuous force applied to the shaft in some methods of mounting (for example, belt tension) and the force by load torque (for example, moment/pulley radius).
- The belt tension is critical particularly when a timing belt is used. Belts that are too tight may cause breakage of the shaft or premature bearing failure. Belt tension must be controlled so as not to exceed the limits calculated from the permissible radial load indicated above.
- In some operating conditions, the pulley diameter or gear size needs to be checked. For example, when using the model α 6/3000 with a pulley/gear with a radius of 1.5 cm (2 in) or less, the radial load when 230 in-lb of peak torque is provided by the motor will exceed the 154 lb maximum rating. In the case of the timing belt, the belt tension is added to this value, making it necessary to support the shaft end.
- When using a timing belt, shaft failure or bearing overload can be minimized by positioning the pulley as close to the bearing as possible.
- Since a standard single row, deep-groove ball bearing is used for the motor bearing, a very large axial load cannot be used. Particularly when using a worm gear and a helical gear, it is necessary to provide another bearing to isolate the thrust load from the searing.
- The motor bearing is generally fixed with a C-snap ring, and there is a small play in the axial direction. When this play influences the positioning in the case of using a worm gear and a helical gear, for example, it is necessary to use an additional bearing support.

5.6 α SVU1 Series Amplifier and Panel Cutout Dimensions

The α SVU Series amplifiers are designed with a rear-mounted heat sink that extends through a hole in the mounting plate. This design eliminates most of the heat dissipation inside the control cabinet reducing the temperature rise in the cabinet and the load on cabinet cooling equipment.

This section contains front and side views as well as the panel cutout drawings for the SVU1-80 and SVU1-130 servo amplifier units.

α SVU1-80 and SVU1-130 Dimension Drawings

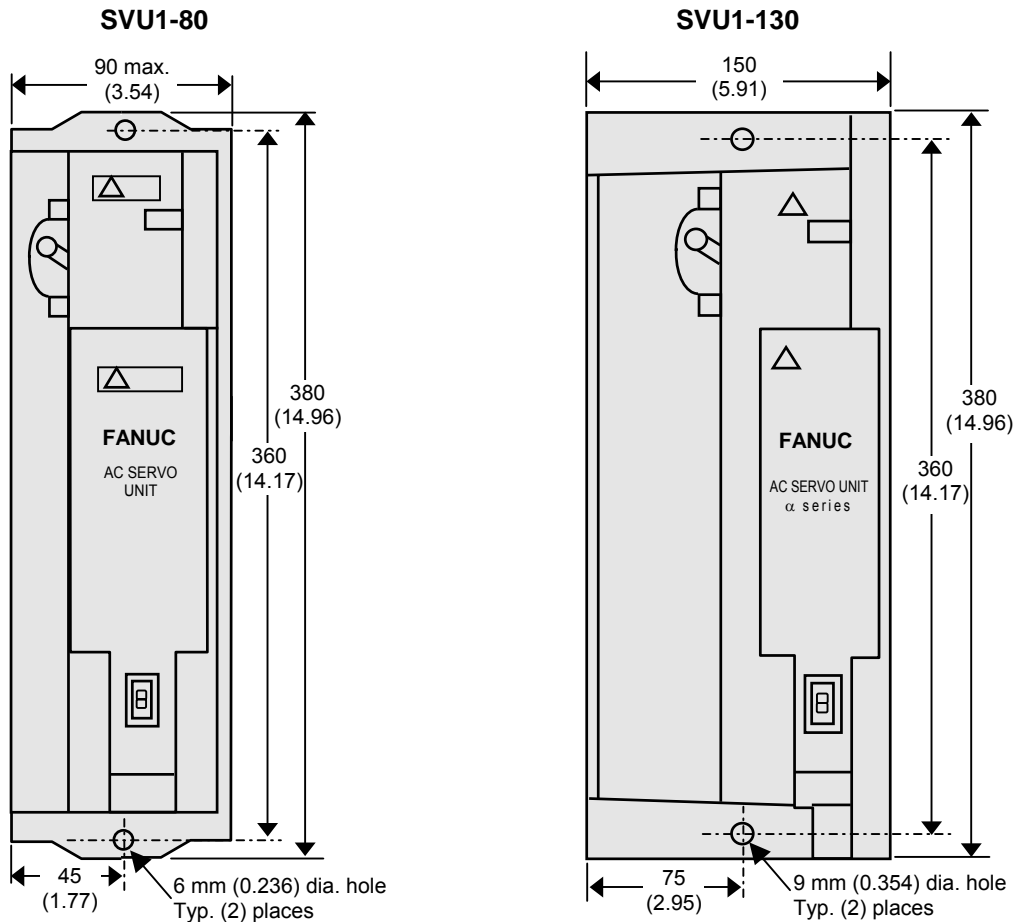

Dimensions shown in mm (in)

Figure I-13. Front view of α SVU1-80 and α SVU1-130 servo amplifiers

Servo Products Specification Guide

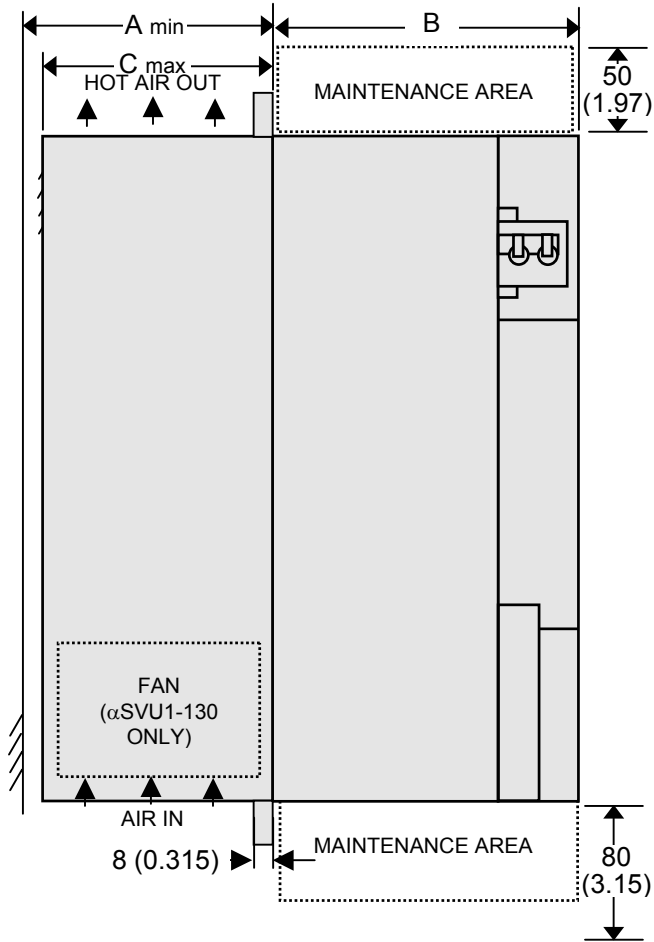

| Dim. | SVU1-80 | SVU1-130 |
|------|------------------|------------------|
| A | 135 mm (5.31 in) | 135 mm (5.31 in) |
| B | 165 (6.50) | 175 (6.89) |
| C | 120 (4.72) | 130 (5.12) |

Dimensions shown in mm (in)

Figure I-14. Side view of αSVU1-80 and αSVU1-130 servo amplifiers

NOTE

The α SVU Series amplifiers and regenerative discharge units have rear heat sink extensions designed to protrude through the customer's control cabinet. This design allows the amplifier's heat to be dissipated outside the control cabinet, reducing the load on enclosure cooling equipment. Panel cut out drawings are shown on the next page.

α SVU1-80 and SVU1-130 Panel Cutout Drawings

SVU1-80

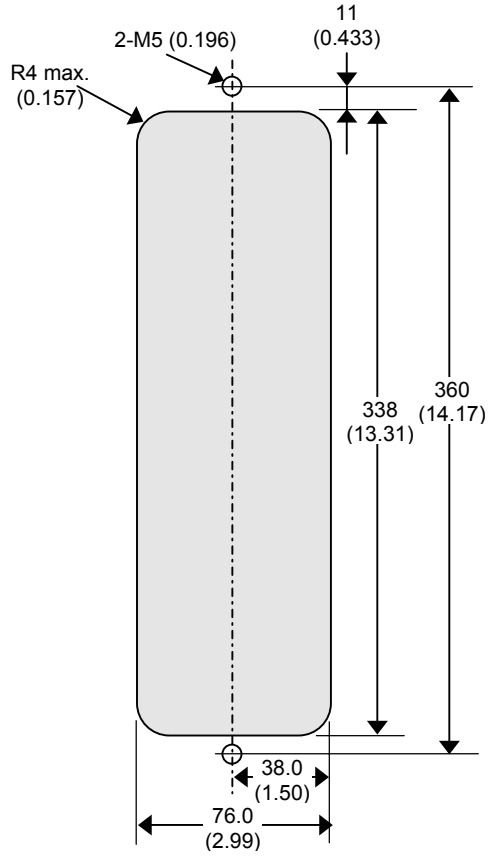

SVU1-130

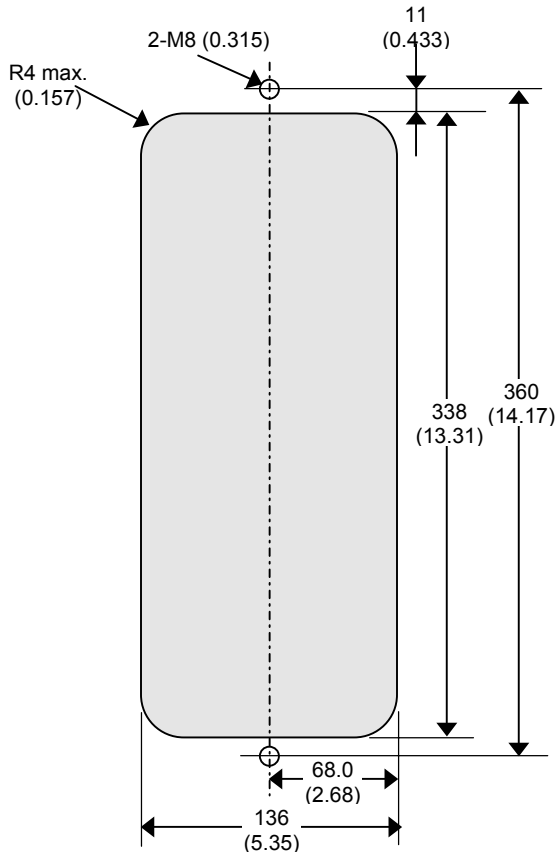

Dimensions shown in mm (in)

Figure I-15. Panel cut out drawings of *α* SVU1-80 and *α* SVU1-130 servo amplifiers

5.7 α SVU Series Switch Settings

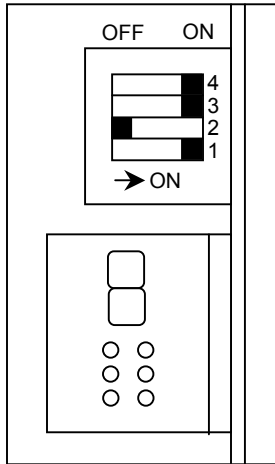

There are four channel switches located above the 7-segment LED and behind the terminal board cover on the front of the α Series servo amplifiers. These switches should be set as described below before use of the α SVU series servo amplifiers.

Figure I-16. α SVU Series channel switches

Positions:

The switches are sequentially numbered 1, 2, 3, and 4 with the one at the bottom as switch 1. The OFF position is on the left, and the ON position is on the right.

Switch 1 Setting:

Always set to ON.

Switch 2 Setting:

Always set to OFF for α SVU1 Series.

NOTE: If the switch 2 setting is incorrect, the VRDY OFF alarm may occur.

Switch 3 and 4 Setting:

The setting of these switches depends on the regenerative discharge resistance used:

Table I-11. Switch 3 and 4 setting for α SVU1 Series amplifiers

| SVU1-80 | | | SVU1-130 | | |
|----------------------------------|-----|-----|----------------------------------|-----|-----|
| Regen. Discharge Unit | SW3 | SW4 | Regen. Discharge Unit | SW3 | SW4 |
| Built-in (100 W) | ON | ON | Built-in (400 W) | ON | ON |
| Separate ZA06B-6089-H500 (200 W) | ON | OFF | Separate ZA06B-6089-H711 (800 W) | ON | OFF |
| Separate ZA06B-6089-H713 (800 W) | OFF | OFF | | | |

5.8 Noise Protection

Separation of Signal and Power Lines

When routing signal and power lines, the signal lines must be separated from the power lines to ensure best noise immunity. Table I-12 below lists the types of cables used:

Table I-12. Servo amplifier signal line separation

| Group | Signal | Action |
|-------|--|---|
| A | Amplifier input power line, motor power line, MCC drive coil | Separate these cables from those of group B by bundling them separately* or by means of electromagnetic shielding**. Attach a noise preventer or suppressor, such as a spark arrester, to the MCC drive coil. |
| B | Cable connecting control unit with servo amplifier and serial encoder feedback cable | Separate these cables from those of group A by bundling them separately or by means of electromagnetic shielding*. In addition, shielding must be provided. |

* The bundle of group A cables must be separated from the bundle of group B cables by at least 10 cm.

** Electromagnetic shielding involves shielding groups from each other by means of a grounded metal (steel) plate.

Grounding

A typical machine has three separate grounds:

- **Signal Ground:** Provides the reference potential (0 V) for the electrical signal system.
- **Frame Ground:** Ensures safety and shields external and internal noise.
- **System Ground:** Connects each unit and the inter-unit frame ground system to earth ground.

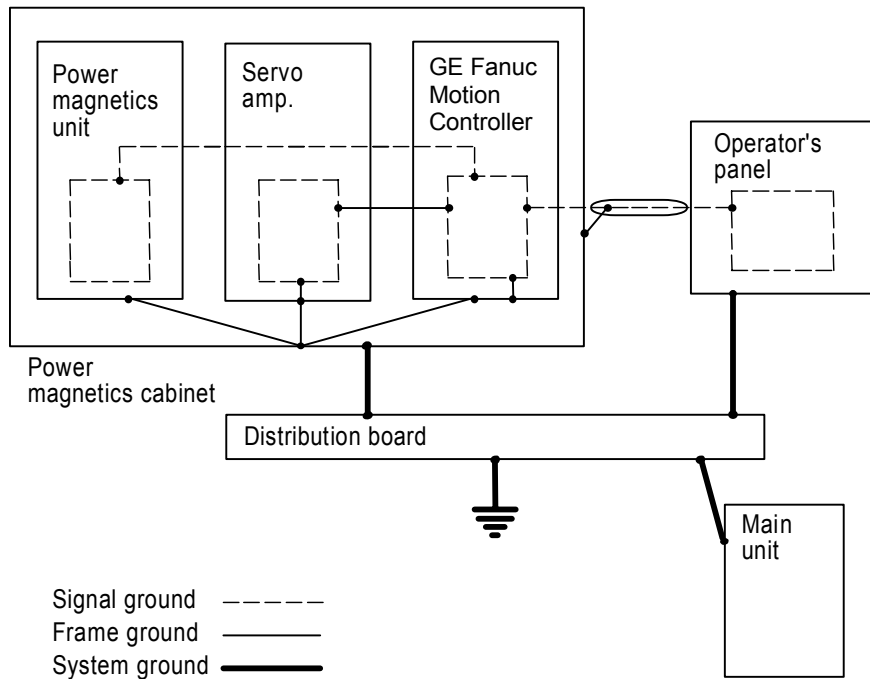

Figure I-17. Ground system

Servo Products Specification Guide

Notes on the ground system wiring for α SVU1 Series amplifiers:

- The ground resistance of the system ground must not exceed 100 ohms (Class-3 ground).
- System ground connection cables must have a sufficiently large cross-sectional area to enable them to safely carry the current that will arise in the event of a problem such as a short-circuit (in general, a cross-sectional area no less than that of the AC power line must be provided).
- The system ground connection cable must be integrated with the AC power line such that power cannot be supplied if the ground wire is disconnected.
- The motor frame must be referenced to earth ground with a class 3 (100 ohms or less) system ground. Use an ohmmeter to measure the resistance from the servomotor frame to a known earth ground rod or grid. The frame-to-ground resistance should be within 1 to 2 ohms.

In a high noise environment, installing a ground wire on the motor frame and routing it directly to the nearest available earth ground can improve noise immunity. Some servo motors have a tapped hole on the frame or a blind hole that can be tapped. For smaller motors, connect to the motor mounting bolts.

- The Motor Power cable should not be a shielded cable. If a custom built cable with shield was used for motor power, lift the shield connection at both ends of the cable. If a shield is attached, especially at the motor end, it acts as an antenna to couple noise into the encoder.
- The Motor Feedback cable should have the Z44B295864-001 Grounding Bar and one ZA99L-0035-001 Grounding Clamp per axis installed near the amplifier. Confirm that the grounding bar is referenced to earth ground with a class 3 (100 ohms or less) system ground. Use an ohmmeter to measure the resistance from the grounding bar frame to a known earth ground rod or grid. The frame to ground resistance should be within 1 to 2 ohms.

In a high noise environment, installing a ferrous bead on the feedback cable within a short distance of the amplifier connector can also improve noise immunity.

- Separation of Motor Power and Motor Feedback cables: Group A signals (Amplifier main AC power, Motor Power Cable and MCC drive coil) signals must be separated from Group B signals (Motor Feedback cable) by at least a 10cm distance. Do not tie Group A and B signals together with cable ties or wraps at any point. An alternative is to separate these two groups by means of a grounded metal (steel) plate.
- The MCC relay used to switch the three-phase AC main power to the amplifier should have an appropriate noise (spark arrester) on its drive coil.
- An AC line filter is recommended to suppress high frequency line noise on the amplifier main power lines. When an isolation transformer is used to convert AC main power to amplifier input power levels, the AC line filter is not required. GE Fanuc supplies an acceptable three-phase line filter sized for 5.4KW or 10.5KW especially for this purpose. This filtered AC main power should not be shared with other equipment in the panel, especially with devices such as inverter drives or motor starters that have high power consumption.
- Amplifier Chassis Ground must be referenced to earth ground with a class 3 (100 ohm or less) system ground. Use an ohmmeter to measure the resistance from the amplifier frame to a known earth ground rod or grid. A tapped and threaded hole is provided on the amplifier frame for this purpose.
- AC Main PE Ground is supplied in accordance to local code practices and may vary, depending on AC power distribution in the facility. In general the PE ground should be referenced to an earth ground and not indicate common mode voltage to the instrumentation earth ground.

5.9 Command Cable Grounding

The GE Fanuc controller cables that require shielding should be clamped by the method shown below. This cable clamp treatment provides both cable support (strain relief) and proper grounding of the shield. To ensure stable system operation, the cable clamp method is recommended. Partially peel back the cable sheath to expose the shield. Push the clamp (ZA99L-0035-0001) over the exposed shield and insert the clamp hooks into slots on the grounding bar (Z44B295864-001). Tighten the clamp to secure cable and complete the ground connection. The grounding bar must be attached to a low impedance earth ground.

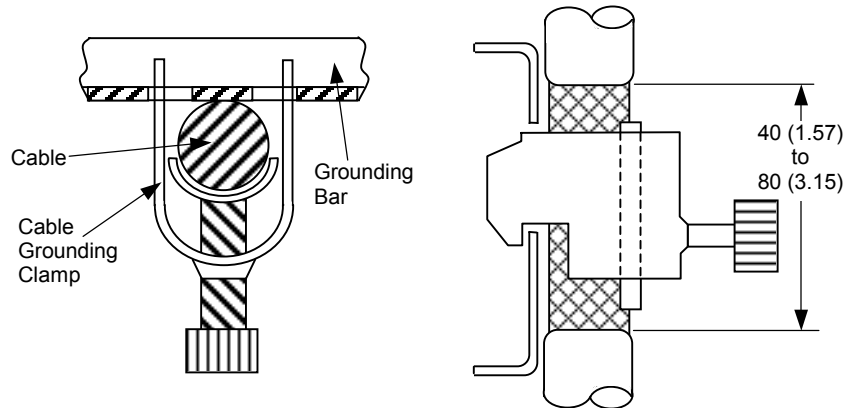

Figure I-18. Cable grounding clamp detail

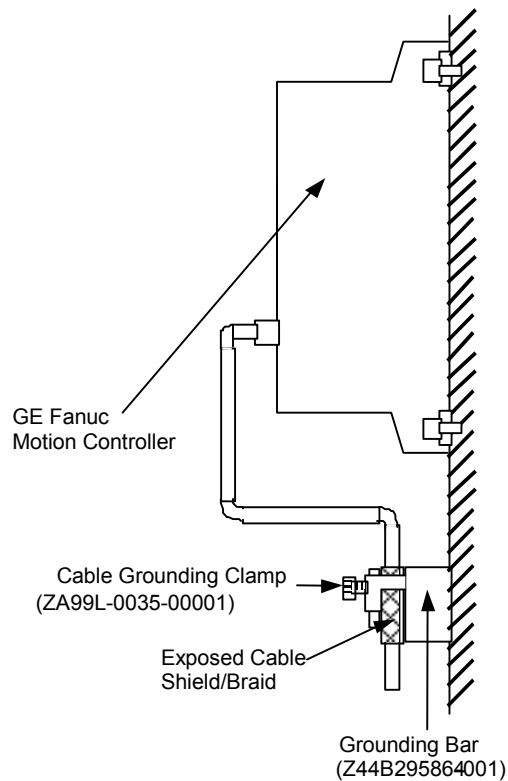

Figure I-19. Command cable shield grounding system

5.10 Selecting a Ground Fault Interrupter

The α Series servo amplifier drives a motor by means of the transistor-based PWM inverter method, in which a high-frequency leakage current flows to ground through the stray capacitance of the motor windings, power cable, and amplifier. A ground fault interrupter or leakage-protection relay, which is installed on the power supply side, can malfunction if such a leakage current should flow. Therefore, you should select an inverter-compatible ground fault interrupter capable of handling the approximate leakage currents shown below to protect against the occurrence of this malfunction:

- **$\alpha 6/3000$** : choose a 1.8 mA commercial frequency component.
- **$\alpha 12/3000$, $\alpha 22/2000$** : choose a 2.0 mA commercial frequency component.
- **$\alpha 30/3000$, $\alpha 40/2000$** : choose a 2.5 mA commercial frequency component.

Section 6: α Servo System Power Requirements

This section provides information about AC amplifier power as well as the discharge of regenerative power.

6.1 Power Line Protection

A circuit breaker, electromagnetic contactor and AC line filter or transformer should be installed as part of your α Series Servo system. GE Fanuc provides the AC line filter as an option. The transformer, circuit breaker, and electromagnetic contactor, however, are user-supplied components. In European countries where power sources are 380 to 400 VAC and neutral grounded, it is necessary to install a transformer.

The same incoming AC control components can be used to provide power to multiple amplifiers, as long as the components are rated for the current and power drawn by the sum of all of the amplifiers.

6.2 AC Line Filter

An AC line filter is recommended to suppress the influences of high-frequency input line noise on the drive power supply. When an isolation-type power transformer is used because a power supply voltage within the specified range is not available, an AC line filter is not required.

If two or more servo amplifiers are connected to one AC line filter, the total continuous output rating of all connected servo amplifiers should be kept below the continuous output rating of the AC line filter. The continuous output rating for the various servos are shown below.

Table I-13. α servo motor continuous output rating

| Motor | Cont. Output Rating |
|---------------------------|---------------------|
| α 6/3000 | 1.4 kW |
| α 12/3000 | 2.8 kW |
| α 22/2000 | 3.8 kW |
| α 30/3000 | 4.8 kW |
| α 40/2000 with fan | 7.3 kW |

If your installation must be EMC compliant, verify that the use of an AC line filter fully satisfies the EMC requirements. You may need to select and install a user-supplied noise filter to meet EMC requirements.

GE Fanuc offers the AC line filters that can be used with the Alpha Series amplifiers:

- 5.4 kW, 3-phase (ZA81L-0001-0083#3C)
- 10.5 kW, 3-phase (ZA81L-0001-0101#C)

Servo Products Specification Guide

Table I-14. AC line filter specifications

| Catalog Number | ZA81L-0001-0083#3C | ZA81L-0001-0101#C | ZA81L-0001-0168 | ZA81L-0001-0169 |
|-----------------------------|---------------------------|--------------------------|------------------------|------------------------|
| Continuous rated current | 24A | 44A | 24A | 41A |
| Max. continuous rated power | 5.4kW | 10.5kW | 5.4kW | 10.5kW |
| Heat dissipation | 20W | 70W | 20W | 70W |
| Weight | 1.1 kg (2.4 lb) | 3.0 kg (6.6 lb) | 1.1 kg (2.4 lb) | 3.0 kg (6.6 lb) |

The dimensions of the AC line filters are as follows

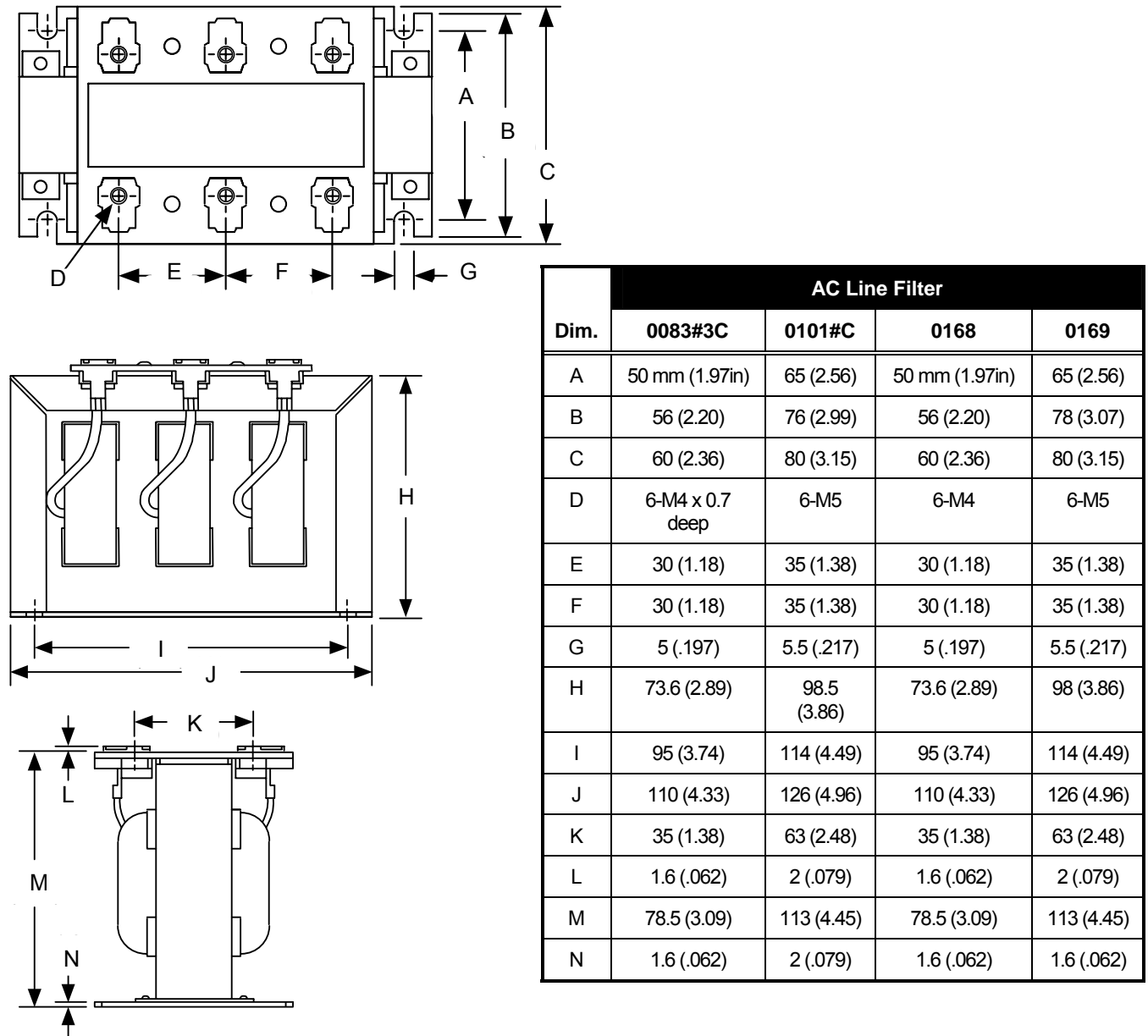

Figure I-20. AC line filter dimension drawing

6.3 Circuit Breaker Selection

To provide proper protection for the amplifier, use a circuit breaker rated at no more than 20 Amps (10A for VDE 1601 compliance for CE marking). Table I-15 will help you select the appropriate circuit breaker for your motion application.

Table I-15. Currents drawn at continuous rated output

| Motor | Input Current 3-phase* |
|------------------|---------------------------|
| α 6/3000 | 6 A (rms) |
| α 12/3000 | 11 A (rms) |
| α 22/2000 | 15 A (rms) |
| α 30/3000 | 21 A (rms) |
| α 40/2000 | 29 A (rms) |

NOTE

When multiple amplifiers are connected to a single circuit breaker, select a breaker by multiplying the sum of the currents listed in Table 65HI-15 by 0.6.*

During rapid motor acceleration, a current that is three times the continuous rating flows. Select a circuit breaker that does not trip when a current that is three times the continuous rating flows for two seconds.

*This factor attempts to compensate for applications where all axes are not demanding full power at the same time. For applications where all axes are running continuously or with high duty cycles, this factor must be increased to 1.

6.4 Electromagnetic Contactor (MCC) Rating

To prepare for incoming AC power, you must also select and install an appropriate electromagnetic contactor (MCC), based on the peak currents for the motors in your system. A contactor is typically required on systems approved to display the CE marking (Machinery Directive). When multiple amplifiers are connected to a single circuit breaker, select a breaker based on the sum of the currents in Table I-15.

6.5 Incoming AC Power

The α SVU Series servo amplifiers require a three-phase AC input for main bus power and a single-phase AC input for control power. Two terminals of the three-phase input (L1 and L2) are connected with the terminals for the single-phase input by jumper bars on terminal board T1 at the factory. If you want to separate the two power supplies, remove the jumper bars. The power requirements for these supplies are shown below:

Table I-16. AC and control power

| Specification | Description |
|--|------------------------|
| Voltage: 3-phase | 200 VAC to 240 VAC |
| Frequency | 50 Hz, 60Hz \pm 2 Hz |
| Voltage fluctuation during acceleration/deceleration | 7% or less |

Table I-17. Control power current

| Amplifier Model | Control Power Current |
|-------------------|-----------------------|
| α SVU1-80 | 150 mA |
| α SVU1-130 | 300 mA |

AC Power Ratings

The power supply rating required when using multiple servo motors can be determined by summing the requirements of the individual motors.

The power supply ratings listed in Table I-18 are sufficient as continuous ratings. Note, however, that servo motor acceleration causes a current to momentarily flow that is approximately three times the continuous flow rating.

When the power is turned on, a surge current of about 37A (when 264VAC is applied) flows for 20 msec.

Table I-18. Three-phase power supply ratings

| Motor | Power Supply Rating | Current @ 230 VAC |
|---------------------------|---------------------|-------------------|
| α 6/3000 | 2.2 kVA | 6 A |
| α 12/3000 | 4.3 kVA | 11 A |
| α 22/2000 | 5.9 kVA | 15 A |
| α 30/3000 | 8.2 kVA | 21 A |
| α 40/2000 with fan | 11.3 kVA | 29 A |

6.6 Discharging Regenerative Energy

Regenerative energy is normally created in applications with a high load inertia or frequent acceleration and deceleration. When decelerating a load, the stored kinetic energy of the load causes generator action in the motor causing energy to be returned to the α Series amplifier.

The α SVU amplifiers have a regenerative discharge resistor built in to dissipate this energy. For light loads, low acceleration rates, or low speed machines, the amplifier may be able to handle the regenerated energy. Some applications may require the assistance of a separately mounted external regenerative discharge unit. Vertical axes with no counter balance may generate excessive regenerative energy. These units comply with VDE 0160, European Safety Standards for CE marking.

Three separate regenerative discharge units are available for the α SVU Series amplifiers:

- 16 Ω , 200 W (ZA06B-6089-H500) for the SVU1-80 (weight of 2.2 Kg [4.8 lb])
- 16 Ω , 800 W (ZA06B-6089-H713) for the SVU1-80 (weight of 5 Kg [11 lb])
- 8 Ω , 800 W (ZA06B-6089-H711) for the SVU1-130 (weight of 5 Kg [11 lb])

Calculations to determine if a separate regenerative discharge unit is required are shown in “Calculating the Average Regenerative Energy.”

If the regenerative discharge unit overheats, a built-in thermostat is tripped, the external overheat alarm is issued, and the motor is stopped. If an external regenerative discharge unit is required, a separate unit must be installed for each amplifier. This component cannot be daisy-chained. The dimensions for these units are shown in on page I-38. Connections for cables K7 and K8 are shown on p. I-52 of this document.

Calculating the Average Regenerative Energy

Use the following calculation to determine the average regenerative power that will be released in your application (ambient temperature is assumed not to exceed 55°C). Based on the calculations, a separate regenerative discharge unit may be required. If this is the case, select either the 200 W or 800 W regenerative discharge unit as appropriate for the amplifier model. The watt rating of the selected unit must exceed the average calculated regenerative power.

$$\begin{array}{rclclcl}
 \text{Average} & & & & \text{Power} & & \text{Vertical Power} \\
 \text{Amount of} & = & \text{Rotational Power Released} & - & \text{Consumed} & + & \text{Released During} \\
 \text{Regenerative} & & \text{During Deceleration (P}_1\text{)} & & \text{through Axis} & & \text{Downward} \\
 \text{Discharge (W)} & & \text{(STEP 1)} & & \text{Friction (P}_2\text{)} & & \text{Motion (P}_3\text{)} \\
 & & & & \text{(STEP 2)} & & \text{(STEP 3)}
 \end{array}$$

Servo Products Specification Guide

STEP 1—Rotational power released during deceleration (P_1)

$$P_1 = (6.19 \times 10^{-4}) \times (J_m + J_L) \times \omega_m^2 / F \text{ watts}$$

where:

| | | |
|------------|---|-------------------------|
| F | Deceleration duty (Example: deceleration once per 5 second cycle, F=5) | (sec) |
| J_m | Motor rotor inertia $\alpha 6/3000 = 0.0174$ $\alpha 12/3000 = 0.0555$ $\alpha 22/2000 = 0.1041$ $\alpha 30/3000 = 0.1475$ $\alpha 40/2000 = 0.1996$ | (lb-in-s ²) |
| J_L | Load inertia converted to motor shaft inertia | (lb-in-s ²) |
| ω_m | Maximum motor speed at time of deceleration | (rpm) |

STEP 2—Power consumed through axis friction (P_2)

$$P_2 = (5.91 \times 10^{-3}) \times t_a \times \omega_m \times T_L / F \text{ Watts}$$

where:

| | | |
|------------|--|---------|
| ω_m | Maximum motor speed at time of deceleration | (rpm) |
| t_a | Worst case/deceleration time (shortest time) | (sec) |
| T_L | Machine friction torque | (in-lb) |
| F | Deceleration duty | (sec) |

STEP 3—Vertical power released during downward motion (P_3)

(this term applies only for vertical axis operation)

$$P_3 = (1.182 \times 10^{-2}) \times T_h \times \omega_m \times \frac{D}{100} \text{ Watts}$$

where:

| | | |
|------------|---|-------|
| ω_m | Motor speed during rapid traverse | (rpm) |
| T_h | Upward supporting torque applied by the motor during downward motion | (sec) |
| D | Duty cycle of downward operation (Note: The maximum value of D is 50%) | (%) |

Servo Products Specification Guide

STEP 4—Determine if a separate regenerative discharge unit is required

When the average regenerative power produced never exceeds the values indicated in Table 75HI-19, a separate regenerative discharge unit is **NOT** required:

$$\text{Average Regenerative Power} = P_1 - P_2 + P_3$$

Table I-19. Maximum allowable regenerative energy for amplifiers

| Amplifier | Max. Allowable Regen. Power | Used with Motors |
|-------------------|-----------------------------|---|
| α SVU1-80 | 100 watts | α 6/3000, α 12/3000, α 22/2000 |
| α SVU1-130 | 400 watts | α 30/3000, α 40/2000 w/fan |

If the average regenerative power exceeds the value for the amplifier, only then is a separate regenerative discharge unit required. Select a unit from Table 77HI-20 that exceeds the calculated power value.

Table I-20. Regenerative discharge capacity

| Amplifier Model | Unit | Catalog # | No Air Flow | Air Velocity 2m/sec | Air Velocity 4m/sec |
|-------------------|---------------------|-----------------|---------------------------------|---------------------|---------------------|
| α SVU1-80 | 16 Ω , 200 W | ZA06B-6089-H500 | 200 W (as shipped) | 400 W* | 600 W* |
| α SVU1-130 | 8 Ω , 800 W | ZA06B-6089-H711 | Forced cooling fan is installed | | 800 W |
| α SVU1-80 | 16 Ω , 800 W | ZA06B-6089-H713 | Forced cooling fan is installed | | 800 W |

*GE Fanuc does not supply a cooling fan for this unit. These values are supplied for reference only (customer-supplied fan).

Servo Products Specification Guide

EXAMPLE:

Assume a vertical axis using an α 12/3000 motor ($J_m = 0.0555 \text{ lb-in-s}^2$) that decelerates once every 4 seconds ($F = 4$) for 0.10 seconds (t_a) from a maximum speed of 2500 rpm (ω_m). The machine load inertia reflected to the motor shaft (J_L) is 0.05 lb-in-s^2 . The torque (max) required to support the load during a downward move (T_h) is 100 in-lb, and the downward motion is 20% of the cycle (D). Axis friction (T_L) is 35 in-lb.

STEP 1:

$$\begin{aligned} P_1 = \text{Rotational Power} &= (6.19 \times 10^{-4}) \times (0.0555 + 0.05) \times 2000^2/4 \\ &= 65.3 \text{ Watts} \end{aligned}$$

STEP 2:

$$\begin{aligned} P_2 = \text{Friction Power} &= (5.91 \times 10^{-3}) \times 0.10 \times 2000 \times 35/4 \\ &= 10.3 \text{ Watts} \end{aligned}$$

STEP 3:

$$P_3 = \text{Vertical Power} = (1.182 \times 10^{-2}) \times 100 \times 2000 \times \frac{20}{100} = 472.8 \text{ Watts}$$

STEP 4:

$$\begin{aligned} \text{Average Power} &= P_1 - P_2 + P_3 \\ &= 65.3 - 10.3 + 472.8 \\ &= 527.8 \text{ Watts} \end{aligned}$$

(Note the large value associated with the non-counterbalanced vertical load)

Since this value is larger than the 100 W internal capacity of the α SVU1-80 amplifier used with this motor, a separate regenerative discharge unit is required. The ZA06B-6089-H713 unit is adequate since its 800 W rating exceeds the 539.1 W average for the application. With a customer-supplied fan with at least a 4 m/sec flow rate, the ZA06B-6089-H500 unit could also be used.

Regenerative Discharge Unit Dimensions

The separate regenerative discharge units are designed with a rear-mounted heat sink that extends through a hole in the mounting plate. This design eliminates most of the heat inside the control cabinet. This section contains the dimensions for the units, and Section 0 shows the necessary panel cutouts to properly mount the units in an enclosure.

ZA06B-6089-H500 (200 W) for the α SVU1-80

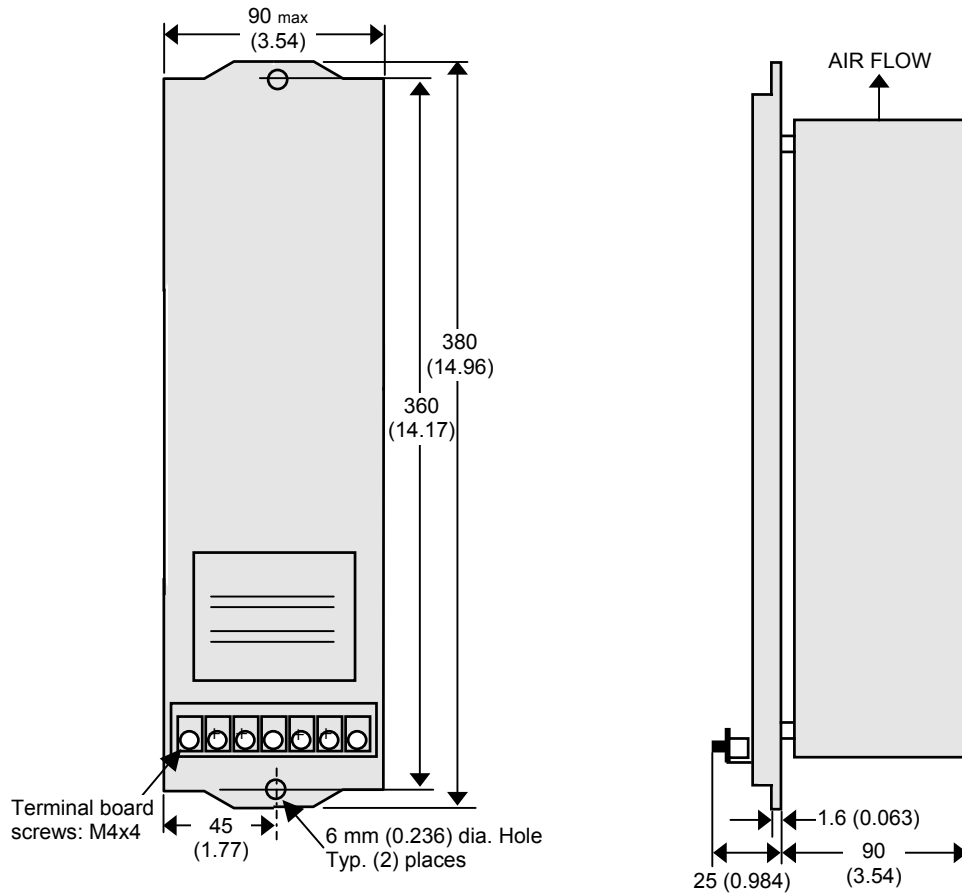

Figure I-21. 200 W Regenerative discharge unit (ZA06B-6089-H500), front, side, and end views

Servo Products Specification Guide

ZA06B-6089-H711 (800 W) for the α SVU1-130 and ZA06B-6089-H713 (800W) for the α SVU1-80

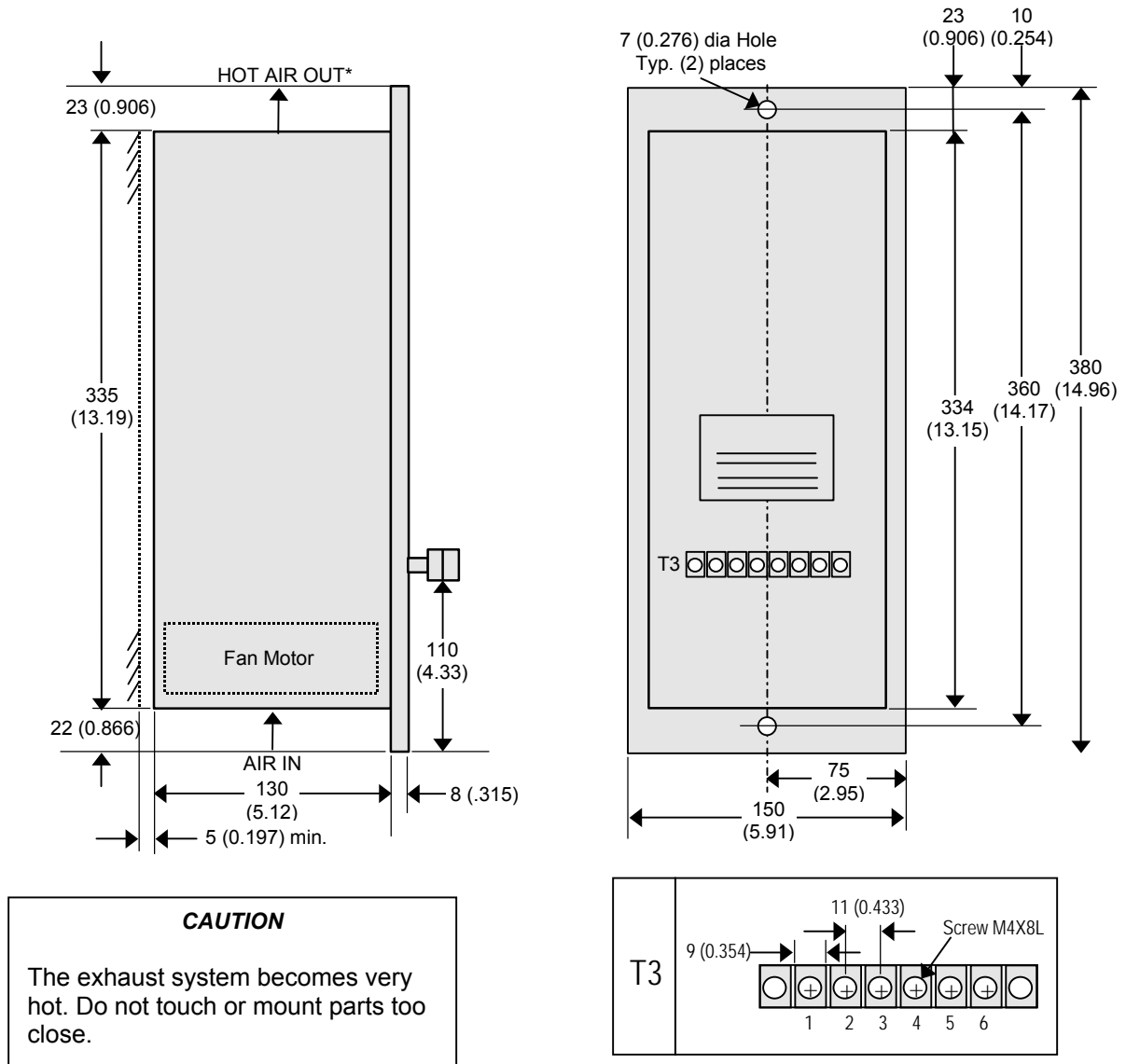

Figure I- 22. 800 W Regenerative discharge unit (ZA06B-6089-H711, ZA06B-6089-H713), front, side, and end views and T3 terminal detail

Regenerative Discharge Unit Panel Cutout Dimensions

The panel cutouts necessary to mount the separate regenerative discharge units are shown below.

ZA06B-6089-H500 (200 W) for the α SVU1-80

ZA06B-6089-H711 (800 W) for the α SVU1-130

ZA06B-6089-H713 (800 W) for the α SVU1-80

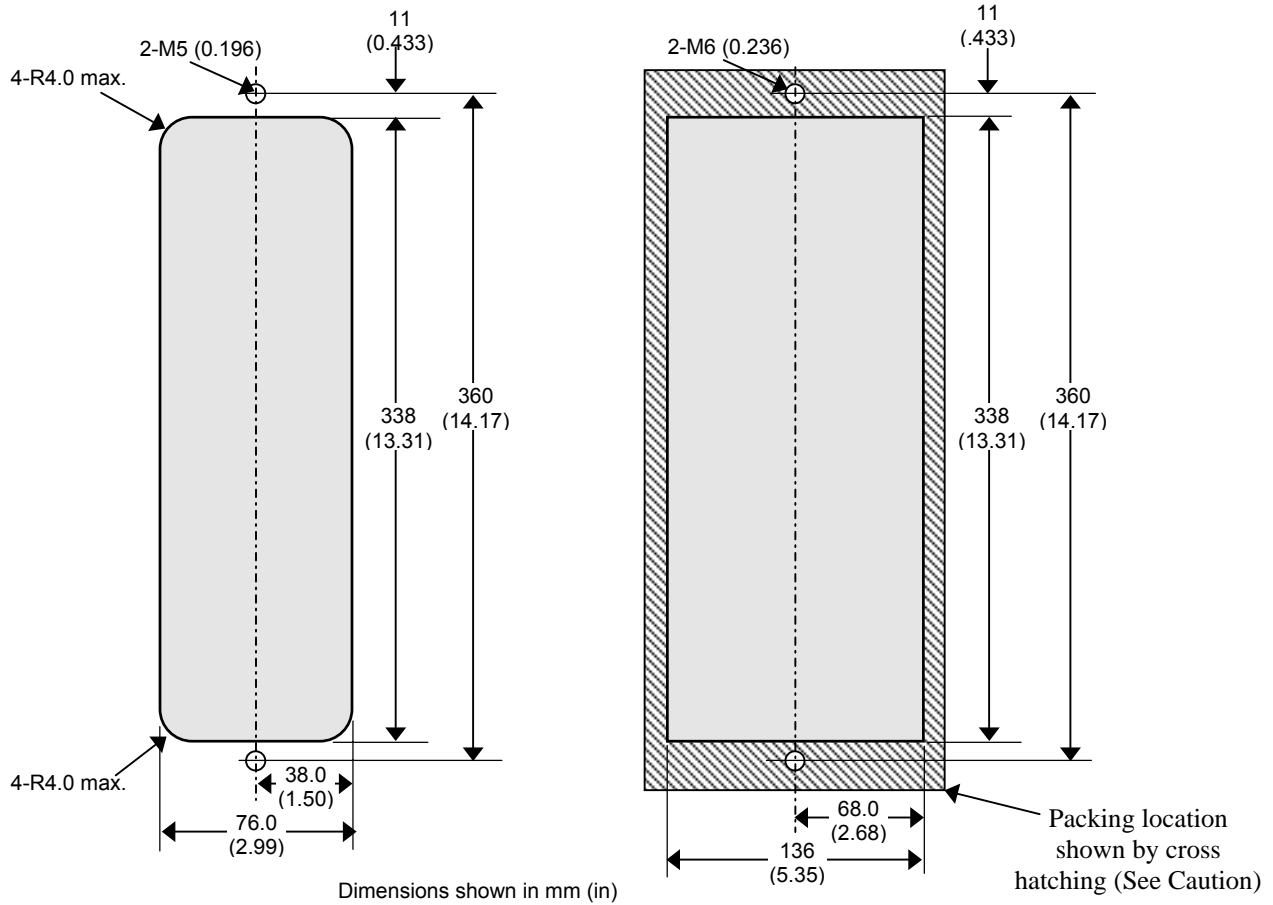

CAUTION:
 Attach packing (acrylonitrile-butadiene rubber or soft NBR) around the cutout to keep out oil and dust.

Figure I-23. Regenerative discharge unit panel cutout dimensions

Section 7: α Servo System Connection

7.1 α SVU1 Amplifier Connections

Power terminations are connected to the α SVU amplifiers on Terminal Board T1 located on the front of the amplifier. The terminals are shielded by a hinged cover that includes a convenient label indicating the terminal designations, as shown in Figure 83HI-24. Terminals are M4 screws and will accept stripped wire, spring spade, or ring terminals.

α SVU1-80
(ZA06B-6089-H105)

α SVU1-130
(ZA06B-6089-H106)

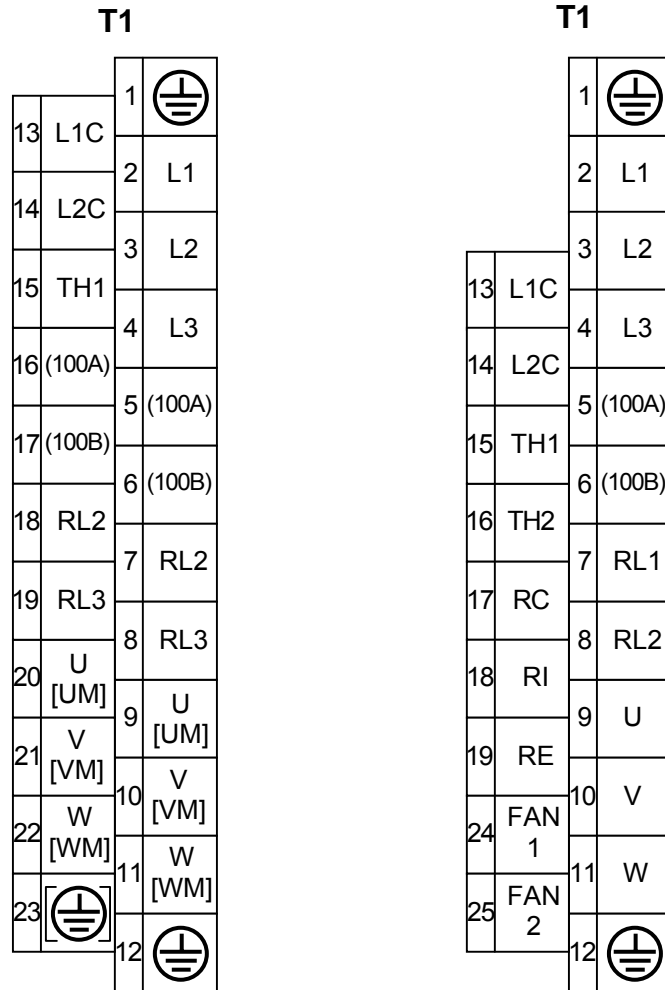

NOTE

5 and 6 on terminal board T1 are not used with the α SVU1 Series.

Figure I-24. α SVU amplifier terminal designations

Servo Products Specification Guide

Signal and control cables are interfaced to the amplifiers using connectors on the bottom of the unit. Location and designation of each connector is shown in Figure 86HI-25.

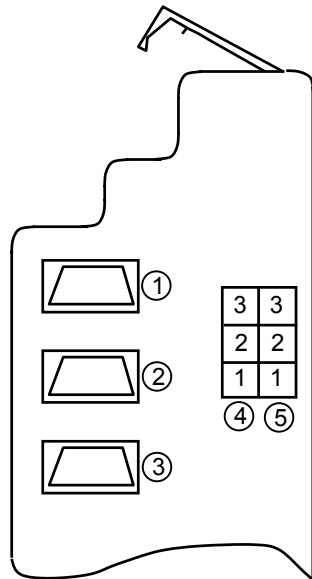

| # | Connector Description | Connector Label | Remarks | See Section 7.4 |
|---|--|-----------------|--------------------------|-----------------|
| ① | Connector for GE Fanuc Motion Controller or CNC Interface | JS1B | N/A | K1 cable |
| ② | Connector for Serial Encoder | JF1 | N/A | K2 cable |
| ③ | Connector for Serial Encoder Battery | JA4 | N/A | K9 cable |
| ④ | Connector for 24V power supply (connector keyed for Y position) | CX3 | pin 1 pin 3 | K10 cable |
| ⑤ | Connector for E-Stop input signal (connector keyed for X position) | CX4 | pin 2; ESP pin 3; 24V | K5 cable |

Figure I-25. Bottom view of α SVU amplifier

7.2 α System Connections

When planning your system, it is important to determine how the different parts of the system connect together. Cable reference numbers K1 through K15 on the α Servo Connection Diagram in Section 7.3 and in Table 90HI-22 indicate the required and optional system connections.

The α Series motor and amplifier connectors required for the system are available from GE Fanuc.

GE Fanuc supplies connectors to allow you to manufacture cables to the specific length required by your system design. GE Fanuc does offer finished cables as options for many connections. See the Cable Connections chart that follows for more information.

An external contactor (MCC) connector (ZA06B-6089-K201) and E-Stop connector (ZA02B-0120-K321) are shipped with each α Series servo amplifier package.

Optional As are also available for the various and feedback cables.

Table I-21. Available motor cable connectors for α Servo systems

| Part Number | Description |
|-----------------|---|
| Z44A730464-G18 | Motor Power Connector Kit, α 6/3000 |
| Z44A730464-G20 | Motor Power Connector Kit, α 12/3000 and α 22/2000 |
| Z44A730464-G21 | Motor Power Connector Kit, α 30/3000 and α 40/2000 |
| ZA06B-6050-K115 | Motor Encoder Connector Kit, α 6/3000 |
| Z44A730464-G24 | Motor Encoder Connector Kit, α 12/3000, α 22/2000, α 30/3000, and α 40/2000 |
| Z44A730464-G26 | Motor Brake Connector Kit, all α Series motors |

Servo Products Specification Guide

Table I-22. Cable Connections

| Ref. | Connects | Prefinished Cable Part Number | Connection Type | When Required |
|------|---|---|---|---|
| K1 | DSM302 to Amplifier (JS1B) | IC800CBL001 (1m) IC800CBL002 (3m) | Servo Command Signal | always |
| K1 | All Other Controllers to Amplifier (JS1B) | IC800CBL003 (2m) | Servo Command Signal | always |
| K2 | Built in Serial Encoder to Amplifier (JF1) | CF3A-2MPB-0140-AZ | Motor Encoder Feedback | always |
| K3 | AC Power Supply to Amplifier | N/A | 3-Phase Servo Power | always |
| K4 | Amplifier to Motor (Prefinished cables include separate cable to connect motor frame ground to customer's earth ground.) | IC800CBL061 (α 6/3000) [14m] IC800CBL062 (α 12/3000, α 22/2000) [14m] CP5A-1MPB-0140-AZB (α 30/3000, α 40/2000) [14m] | Motor Power | always |
| K5 | Amplifier E-stop contact (CX4) to machine E-stop contact | N/A | Emergency Stop | always |
| K6 | AC Control Power Supply to Amplifier | N/A | Amplifier Control Power | always |
| K7 | Amplifier to Regenerative Discharge Unit | N/A | Separate Regenerative Discharge Unit | in some cases ¹ |
| K8 | Regenerative Discharge Unit Over Temperature Switch to Amplifier | N/A | Separate Regenerative Discharge Unit | in some cases ¹ |
| K9 | Amplifier (JA4) to Encoder Backup Battery Unit | 44C741863-001 | Absolute Encoder Battery | with battery option ² |
| K10 | Control to MCC Coil Connector (CX3) on Amplifier | N/A | Emergency Stop/Power Enable | control-dependent; consult your control documentation |
| K11 | Amplifier to Regenerative Discharge Unit Cooling Fan | N/A | Separate Regenerative Discharge Unit Fan Supply Cable | in some cases ¹ |
| K12 | 90 VDC Brake Power Supply to Motor Brake | Z44C742238-004 (14m) | Motor Brake Power | with brake option |
| K13 | Motor Cooling Fan to Fan Power Supply | Z44C742238-004 (14m) | Motor Fan Power | α 40/2000 with fan only |

¹ See the Discharging Regenerative Energy section in Section 6.6

² Prefinished cable is provided as a part of a battery pack option

7.3 α SERIES Servo Connection Diagram

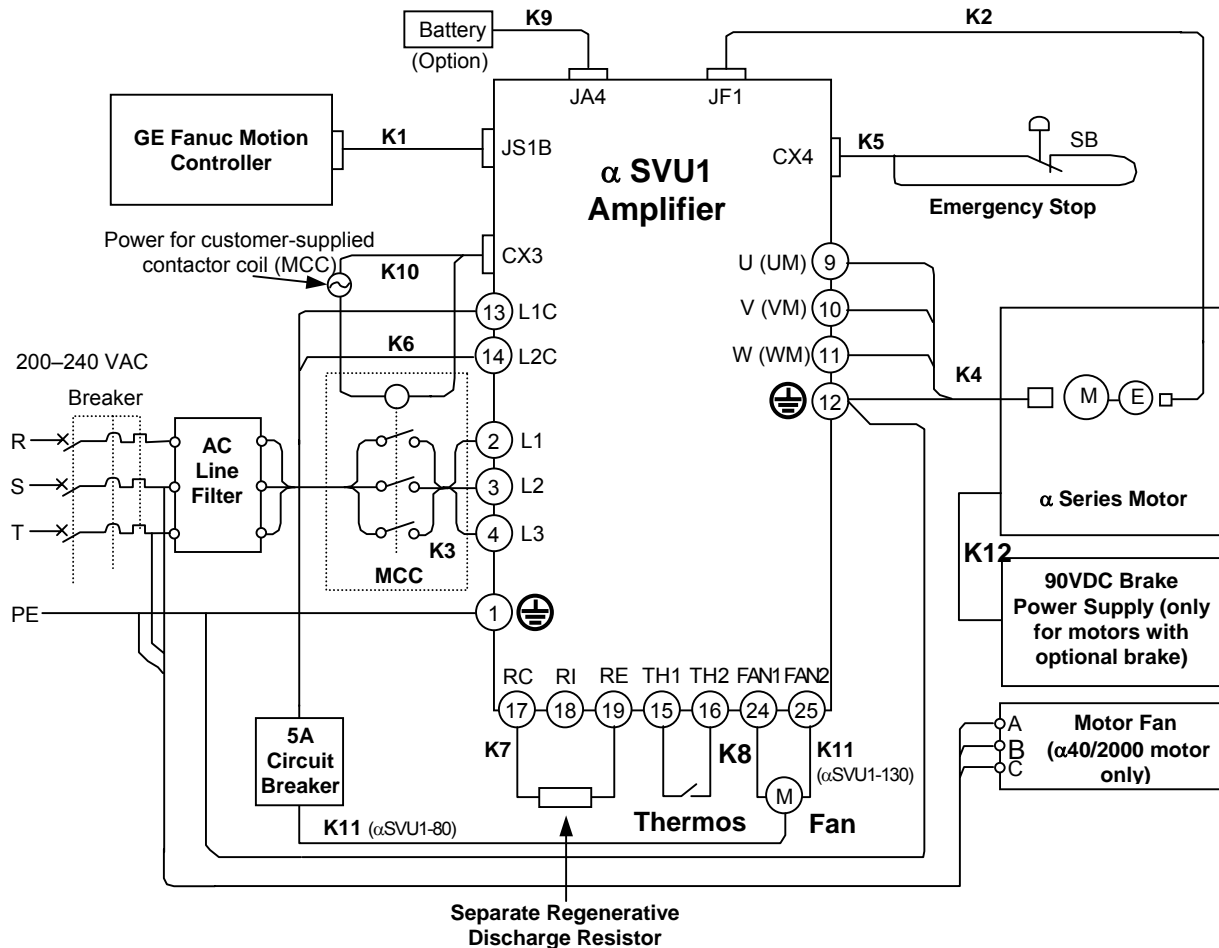

NOTES

- An AC line filter is recommended (unless an isolation transformer is provided) to reduce the effect of harmonic noises to the power supply. Two or more α SVU amplifiers can be connected to one AC line filter if its power capacity is not exceeded.
- RC and RI were connected to each other through a jumper bar at the factory. If a separate regenerative discharge unit will be used, the jumper bar must be removed.
- TH1 and TH2 were connected to each other through a jumper bar at the factory. Remove the jumper bar and connect these terminals to the separate regenerative discharge unit and resistor thermal switch.
- Only the α SVU1-130 (ZA06B-6089-H106) has FAN1 and FAN2 terminals. Connect the terminals to the fan motor (K11 cable) of the separate regenerative discharge unit (other than the ZA06B-6089-H106). If a fan is to be used with the α SVU1-80 the fan power should be connected to L1C and L2C through a 5-amp circuit breaker as shown.
- For CE Mark applications, an MCC that complies with European standards should be selected. The user should determine details of the use of the MCC.

7.4 Connection Details

K1—Servo Command Signal Cable (α 6/3000, α 12/3000, α 22/2000, α 30/3000, α 40/2000)

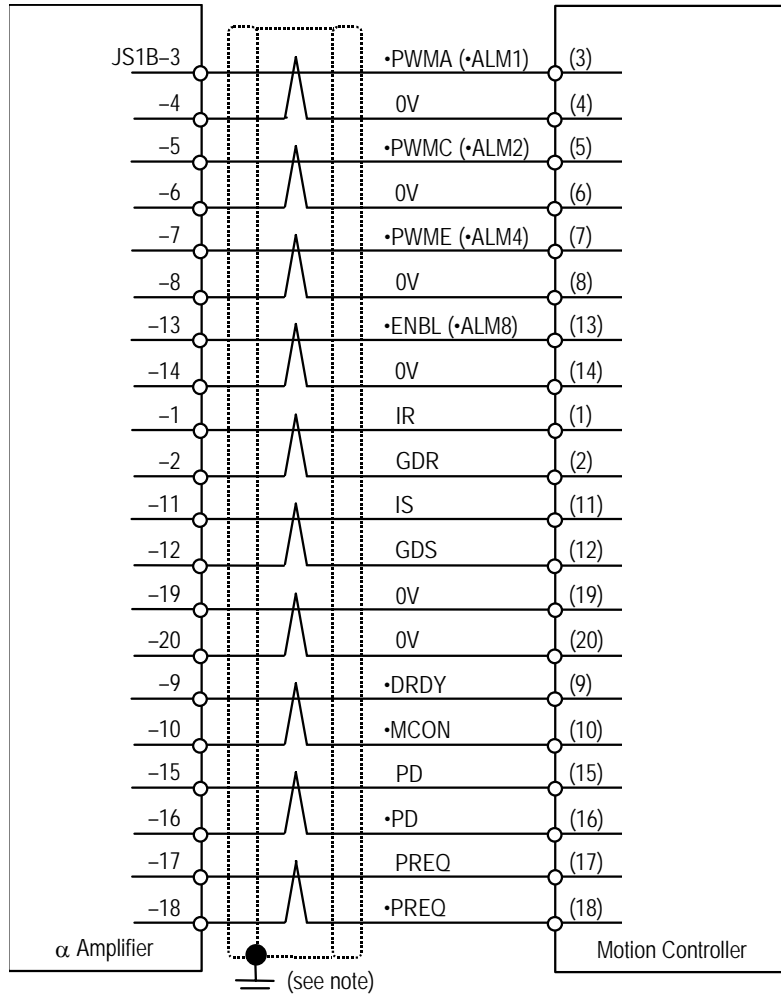

NOTES

The servo command cables for the DSM300 Series controller (IC800CBL001 and IC800CBL002) must be purchased from GE Fanuc. Proper tooling is required to assemble the connectors. For custom length cables, contact your GE Fanuc Distributor or GE Fanuc Sales Engineer.

Grounding the cable shield using the grounding bar (Z44B295864-001) and cable grounding clamp (ZA99L-0035-0001) will provide greater noise immunity.

- Wire: 0.08mm² twisted pair group shielded cable (10 pairs). The following wire is recommended for the K1 cable: 28 AWG x 10 pairs (20 conductors).

Servo Products Specification Guide

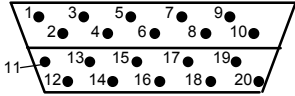
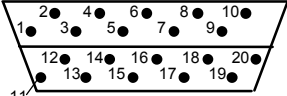
| Cable (K1) | GE Fanuc Part No. | Connector Manufacturer |
|---|--|--|
| DSM300 Controller to Servo Amplifier (JS1B) | IC800CBL001 (1 meter) IC800CBL002 (3 meter) | Cable must be purchased from GE Fanuc (connectors not sold separately)* |
| GE Fanuc controller other than DSM302 to Servo Amplifier (JS1B) | IC800CBL003 (2 meter) | <p>Hirose Electric Co., Ltd.</p>  <p>Honda Tsushin Kogyo Co., Ltd. (PCR-E20FA)</p>  <p><i>Connectors viewed from back (solder/crimp side).</i></p> |

***NOTE:** DSM302 cables cannot be customer-manufactured and uses a 36-pin connector on its end. The DSM302 module requires IC693ACC355 Axis Terminal Board and either IC693CBL324 (1 meter) or IC693CBL325 (3 meter) Terminal Board Cable to access axis I/O such as Home Switch Input, Over Travel Inputs, or Strobe (registration) Inputs.

K2—Motor Encoder Feedback Cable ($\alpha 6/3000$, $\alpha 12/3000$, $\alpha 22/2000$, $\alpha 30/3000$, $\alpha 40/2000$)

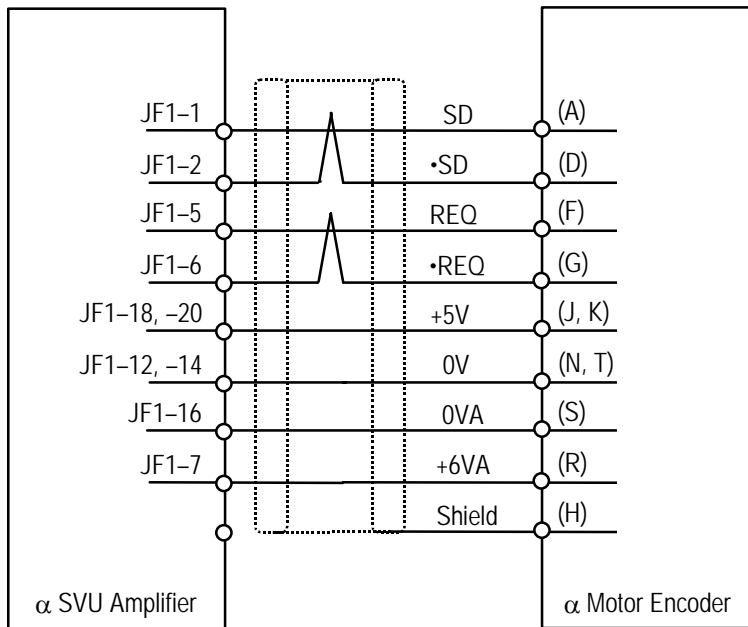

- Prefinished 14m Cable, Part number: CF3A-2MPB-0140-AZ (severe duty)
- Wire: for +5V, 0V use two parallel conductors of 0.5mm² (20 AWG) or larger when the wire length does not exceed 14m. When the wire length exceeds 14m, wire gauge must be increased to ensure that the sum of the electrical resistance of 0V and 5V circuit does not exceed 0.5 ohms. For 6VA, 0VA use 0.5mm² (20 AWG) or larger; for SD, *SD, REQ, *REQ use 0.18mm² (24 AWG) or larger twisted pair with 60% braid shield.

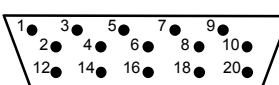
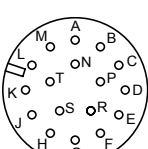
| Connector | GE Fanuc Part No. | Manufacturer |
|-----------------------|--|---|
| Servo Amplifier (JF1) | ZA06B-6073-K214 | Hirose Electric Co., Ltd. (F140-2015S) [connector cover: FI-20-CV]  Connector viewed from back (solder/crimp side). |
| Servo Motor Encoder | Z44A730464-G38 (CE EXT GND pin type) Alpha 6 ZA06B-6050-K115 | Hirose Electric Co., Ltd. (MS3106A 20-29SW, straight) (MS3108B 20-29SW, elbow)  |

K3—Three-Phase Servo Power Cable

For a power supply voltage of 200–240 VAC 50/60 Hz

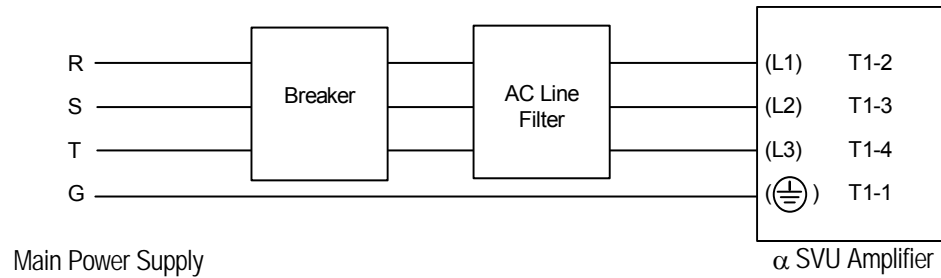

- For αSVU1-80, use 600 V, 4-conductors (JIS C 3312) of 3.5mm² (12 AWG) or larger, heat-resistive vinyl cable (nonflammable polyflex cable with a max. conductor temperature of 105° C) of 3.5mm² (12 AWG) or more.
- For αSVU1-130, use 600 V, 4-conductors (JIS C 3312) of 5.5mm² (10 AWG) or larger.
- Use M4 terminal board screws on α SVU amplifier

K4—Motor Power Cable (α6/3000)

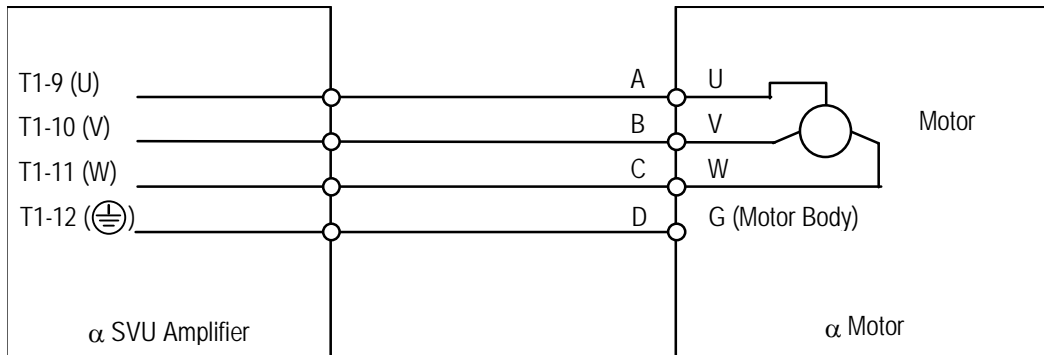

- Prefinished 14m Cable, Part number: IC800CBL061 (severe duty)
- Wire: 4-conductor, 12 AWG, Type S0 power cord, PUR (polyurethane) jacket

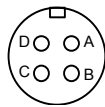
| Connector | Part No. | Maker |
|--------------------------------------|------------------------------------|---|
| Servo Amplifier T1 Terminal Board | N/A (M4 Spring Spade) | N/A |
| Servo Motor | Z44A730464-G20 (CE EXT GND pin) | DDK CE Series (CE02-6A22-22DS)  |

Servo Products Specification Guide

K4—Motor Power Cable (α12/3000, α22/2000)

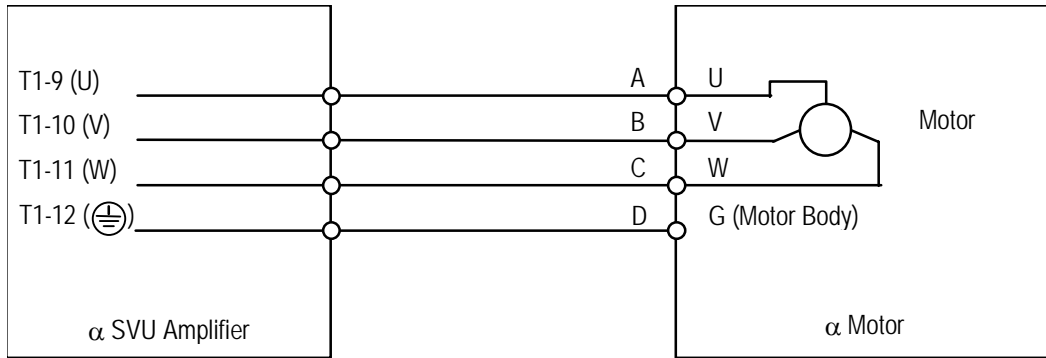

- Prefinished 14m Cable, Part number: IC800CBL061 (severe duty)
- Wire: 4-conductor, 12 AWG, Type S0 power cord, PUR (polyurethane) jacket

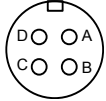
| Connector | Part No. | Maker |
|--------------------------------------|------------------------------------|--|
| Servo Amplifier T1 Terminal Board | N/A (M4 Spring Spade) | N/A |
| Servo Motor | Z44A730464-G20 (CE EXT GND pin) | DDK CE Series (CE02-6A22-22DS)  |

Servo Products Specification Guide

K4—Motor Power Cable (α30/3000, α40/2000)

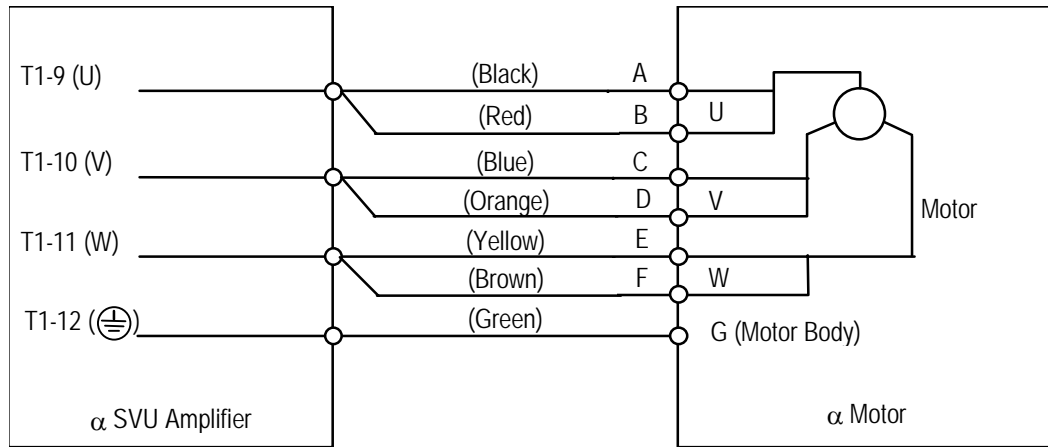

- Prefinished 14m Cable, Part number: CP5A-1MPB-0140-AZB (severe duty)
- Wire: 7-conductor, 12 AWG, Type SO power cord, PUR (polyurethane) jacket

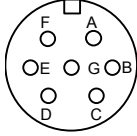
| Connector | Part No. | Maker |
|--------------------------------------|---------------------------------------|---|
| Servo Amplifier T1 Terminal Board | N/A (M4 Spring Spade) | N/A |
| Servo Motor | Z44A730464-G21 (CE EXT GND pin) | DDK CE Series (CE02-6A24-10GS)  |

K5—Amplifier Emergency Stop Connection

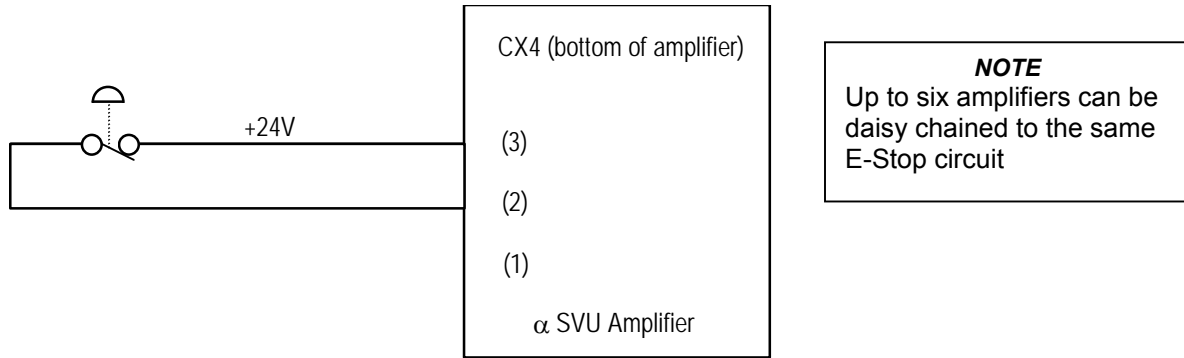

- Wire: 2-conductor 0.75mm² (20 AWG)

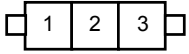
| Connector | GE Fanuc Part No. | Manufacturer |
|---------------------|---|--|
| Servo Amplifier CX4 | ZA06B-0120-K321 (included with amplifier packages) | AMP Housing: 1-178128-3; Contact: 1-175218-2 (crimp terminal)  Connector viewed from wire insertion side. |

K6—Amplifier Control Power Connection

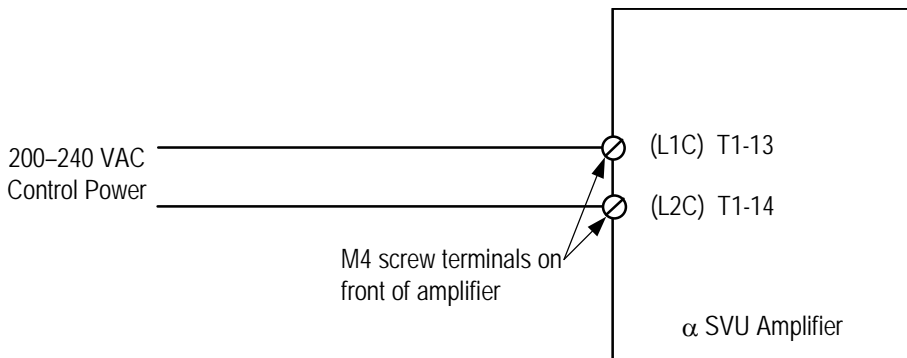

- Wire: 300V, 2-conductor 1.25mm² (16 AWG) or larger

K7—Separate Regenerative Discharge Unit Power Cable
 (α6/3000, α12/3000, α22/2000, α30/3000, α40/2000)

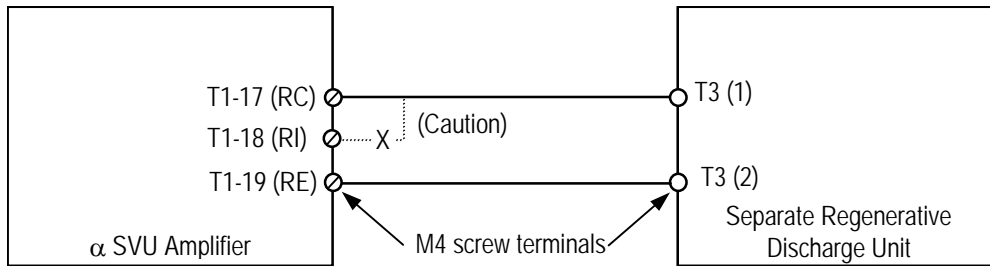

CAUTION

When a separate regenerative discharge unit is connected, remove the factory-installed shorting bar between terminals T1-17 (RC) and T1-18 (RI).

- Wire: 600 V, 2-conductor, 2.0mm² (14 AWG) or larger

K8—Separate Regenerative Discharge Unit Thermal Protection Cable
 (α6/3000, α12/3000, α22/2000, α30/3000, α40/2000)

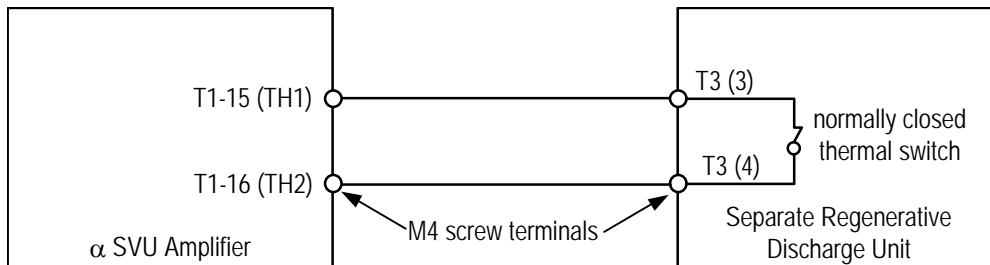

CAUTION

When a separate regenerative discharge unit is connected, the DIP switches on the front of the amplifier must be set for the proper unit. See Section 5.7 for more information.

- Wire: 600 V, 2-conductor, 0.75mm² (18 AWG) or larger

Servo Products Specification Guide

K9—Optional Absolute Encoder Battery Cable ($\alpha 6/3000$, $\alpha 12/3000$, $\alpha 22/2000$, $\alpha 30/3000$, $\alpha 40/2000$)

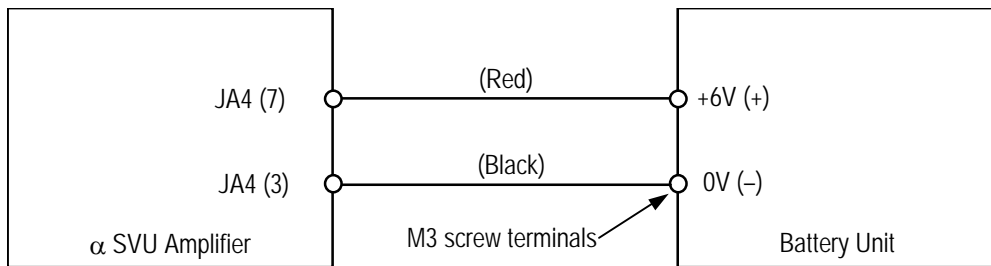

- Prefinished 2m Cable: 44C741863-001 (supplied as a part of α SVU Series Battery Backup Kit IC800ABK001)
- Wire: 2-conductor, 0.75mm² (20 AWG)

| Cable | GE Fanuc Part No. | Connector Manufacturer |
|---------------------|--------------------------|--|
| Servo Amplifier JA4 | ZA02B-0120-K301 | <p>Hirose Electric Co., Ltd.</p> <p>Honda Tsushin Kogyo Co., Ltd. (PCR-E20FA)</p> <p style="text-align: center;"><i>Connectors viewed from back (solder/crimp side).</i></p> |

K10—Emergency Stop/Power Enable Cable
 (α6/3000, α12/3000, α22/2000, α30/3000, α40/2000)

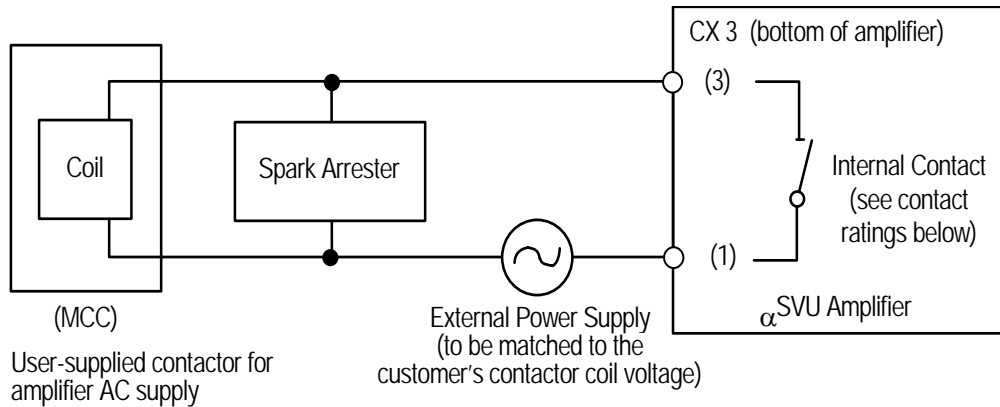

- Wire: 2-conductor, 1.25mm² (16 AWG) or larger

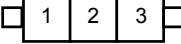
| Connector | GE Fanuc Part No. | Manufacturer |
|---------------------|---|--|
| Servo Amplifier CX3 | ZA06B-6089-K201 (included with α Series amplifier packages IC800APK080 and IC800 APK130) | AMP Housing: 1-178128-3; Contact: 1-175218-2 (crimp terminal)  Connector viewed from wire insertion end |

Contactor Ratings:

| Specification of internal contact | Resistor load (cosφ=1) | Inductance load (cosφ=0.4, L/R=7msec) |
|-----------------------------------|--------------------------|---------------------------------------|
| Rated load | 250 VAC, 5A 30VDC, 5A | 250 VAC, 2A 30 VDC, 2A |
| Max. current | 5A | 5A |

K11—Separate Regenerative Discharge Unit Fan Supply Cable (ZA06B-6089-H711 or ZA06B-6089-H713)

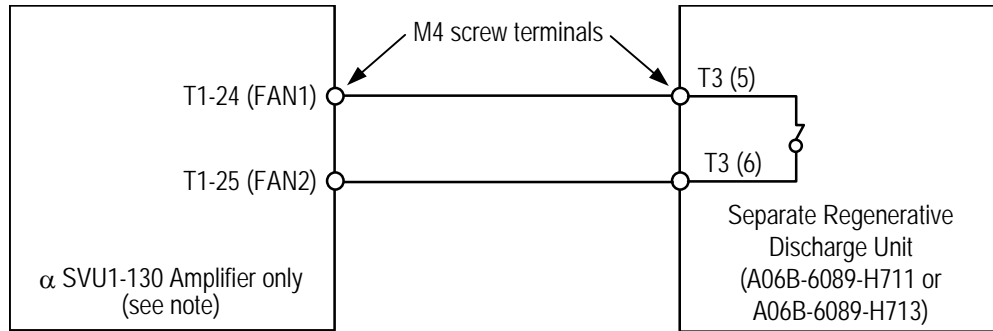

NOTE

Only the α SVU1-130 amplifier has separate fan power supply terminals. When using the ZA06B-6089-H713 unit with the α SVU1-80 amplifier, connect the fan power to terminals T1-13 (L1C) and T1-14 (L2C) through a 5A circuit breaker.

- Wire: 300 V, 2-conductor, 2.0mm² (16 AWG) or larger

K12—Motor Brake Power Connection

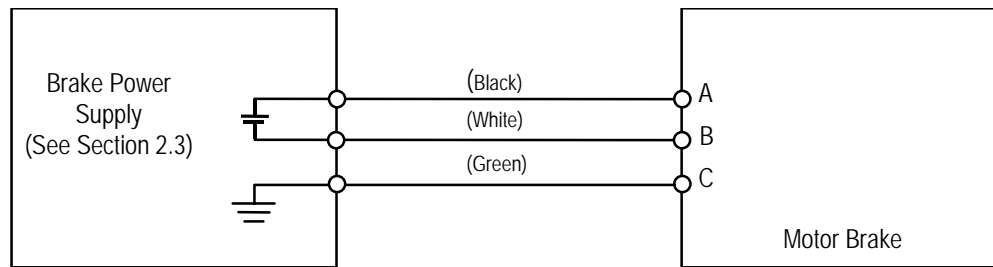

(customer supplied)

- Prefinished 14m Cable, Part number: Z44C742238-004 (severe duty)
- Wire: 330 V, 3-conductor, 20 AWG, 80 °C, PUR (polyurethane) jacket

| Connector | GE Fanuc Part No. | Manufacturer |
|-------------------|-------------------|---|
| Servo Motor Brake | Z44A730464-G26 | AMP 3102A-10SL-3P  Connector viewed from solder side |

Servo Products Specification Guide

K13—Cooling Fan Power Connection (α 40/2000)

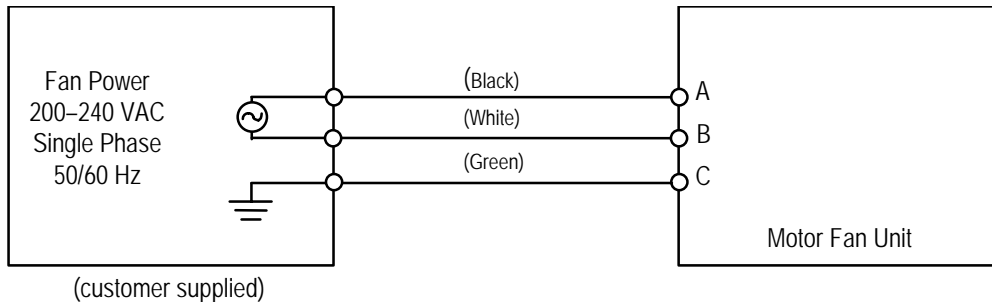

- Prefinished 14m Cable, Part number: Z44C742238-004 (severe duty)
- Wire: 330 V, 3-conductor, 20 AWG, 80 °C, PUR (polyurethane) jacket

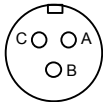
| Connector | GE Fanuc Part No. | Manufacturer |
|------------------|--------------------------|---|
| Servo Motor Fan | Z44A730464-G26 | AMP 3102A-10SL-3P  Connector viewed from solder side |

Fan Voltage/Current Specifications:

| Input voltage | Steady-state current | Surge current |
|----------------------|-----------------------------|----------------------|
| 200V | Approx. 0.85Arms | Approx. 1.60Arms |
| 230V | Approx. 0.98Arms | Approx. 1.84Arms |

Section 8: α SVU Series Protection and Alarm Functions

The Servo Amplifier Unit can detect error conditions and provide alarm information.

The LEDs on the front of the amplifier provide a visual cue to the status of the system by indicating, for example, when the motor and amplifier are ready to function. A built-in, seven-segment LED display indicates when an alarm condition is detected. When an alarm is detected, power is dropped and the motor is stopped by dynamic braking action. Alarm information is displayed as diagnostic data in the GE Fanuc controller. Table 95HI-23 details the alarm conditions the α SVU Series Servo Amplifier System can detect. Table 96HI-24 shows the LED indication for normal operating mode.

Table I-23. α SVU1 Series servo amplifier alarm system

| <i>Alarm Type</i> | <i>LED Ind.</i> | <i>Description</i> |
|---|-----------------|--|
| Over-voltage alarm (HV) | 1 | Occurs if the DC voltage of the main circuit power supply is abnormally high. |
| Low control power voltage alarm (LV) | 2 | Occurs if the control power voltage is abnormally low. |
| Low DC link voltage alarm (LVDC) | 3 | Occurs if the DC voltage of the main circuit power supply is abnormally low or if the circuit breaker trips. |
| Regenerative discharge control circuit failure alarm (DCSW) | 4 | Occurs if the short-time peak regenerative discharge energy is too high or if the regenerative discharge circuit is abnormal. |
| Over-regenerative discharge alarm (DCOH) | 5 | Occurs if the average regenerative discharge energy is too high (too frequent acceleration/deceleration) or the regeneration resistor overheats. |
| Dynamic brake circuit failure (DBRLY) | 7 | Occurs if the relay contacts of the dynamic brake fuse together. |
| Over-current alarm | 8 | Occurs if an abnormally high current flows through the motor. |
| IPM alarm | 8 _a | The Intelligent Power Module (IPM) has detected an alarm due to over-current, overheating, or a drop in IPM control power voltage. |
| Circuit breaker | (trips) | The circuit breaker trips if an abnormally high current (exceeding the working current of the circuit breaker) flows through it. |

Table I-24. α SVU1 Series servo amplifier alarm system

| <i>Type</i> | <i>LED Ind.</i> | <i>Description</i> |
|---------------------|-----------------|--|
| Amplifier not ready | — | The servo amplifier is not ready to drive the motor. |
| Amplifier ready | 0 | The servo amplifier is ready to drive the motor. |

Part II:
 β Servo
System

Section 9: β Servo System Block Diagram

The following block diagram shows the interconnections of a typical β Series servo system:

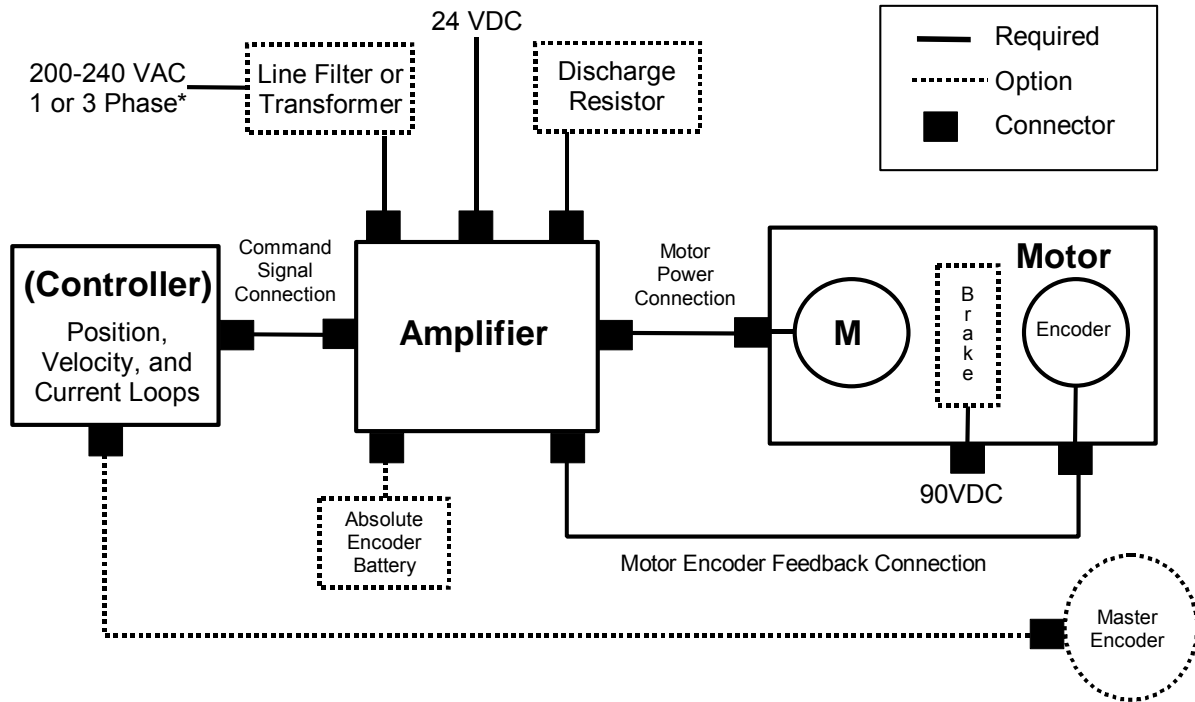

Figure II-1. β Series servo block diagram

NOTE

A 24 VDC power supply, circuit breaker, electromagnetic contactor, surge suppresser, and transformer or line filter should be user-installed as part of the system. See β Servo System Package Options in Section 12: and β Servo Installation in Section 13: of this document for more information.

- For single phase input, the lifetime of the amplifier is reduced because of higher input current. For operation of $\beta 6/2000$ or $\alpha C12/2000$ motors at acceleration/deceleration duty cycles greater than 1 cycle/20 seconds, 3-phase input is recommended. The output power of these motors when operated in ambient temperatures greater than 40°C must be derated linearly at 1%/°C above 40°C up to a maximum ambient temperature of 55°C.

Section 10: β Series Servo Product Overview

10.1 β Series Motors

The β Series servo motors are all digital systems with built-in 32K serial encoders. All β Series motors are available with an optional holding brake. The servo motors must be used with the designated amplifier package and a GE Fanuc motion controller such as the Motion Mate™ DSM 300.

Table II-1 provides a summary of the β Series servo motors. See Section 11: for more detailed motor specifications.

Table II-1. β Series Servo Motors

| Motor | Rated Torque | Power Rating | Required Amplifier Kit | Motor Catalog # |
|-------------------|--|---------------------|-------------------------------|--|
| β 0.5/3000 | 0.5 Nm (5.6 in-lbs) continuous stall torque; 3000 RPM | 0.2 kW | 12 Amp (IC800BPK012) | Motor Only: ZA06B-0113-B075#7008 Motor w/ Brake: ZA06B-0113-B175#7008 |
| β 2/3000 | 2 Nm (17 in-lbs) continuous stall torque; 3000 RPM | 0.5 kW | 12 Amp (IC800BPK012) | Motor Only: ZA06B-0032-B075#7008 Motor w/ Brake: ZA06B-0032-B175#7008 |
| β 3/3000 | 3 Nm (26.6 in-lbs) continuous stall torque; 3000 RPM | 0.5 kW | 20 Amp (IC800BPK020) | Motor Only: ZA06B-033-B075#7008 Motor w/ Brake: ZA06B-033-B175#7008 |
| β 6/2000 | 6 Nm (53 in-lbs) continuous stall torque; 2000 RPM | 0.9 kW | 20 Amp (IC800BPK020) | Motor Only: ZA06B-0034-B075#7008 Motor w/ Brake: ZA06B-0034-B175#7008 |
| α C12/2000 | 12 Nm (106 in-lbs) continuous stall torque; 2000 RPM | 1.0 kW | 20 Amp (IC800BPK020) | Motor Only: ZA06B-0141-B075#7008 Motor w/ Brake: ZA06B-0141-B175#7008 |
| β M0.5/4000 | 0.65 Nm (5.8 in-lbs) continuous stall torque; 4000 RPM | 0.2 kW | 200 Amp (IC800PBK020) | Motor Only: ZA06B-0115-B075#0008 Motor w/ Brake: ZA06B-0115-B175#0008 |
| β M1/4000 | 1.2 Nm (10.6 in-lbs) continuous stall torque; 4000 RPM | 0.4 kW | 200 Amp (IC800PBK020) | Motor Only: ZA06B-0116-B075#7008 Motor w/ Brake: ZA06B-0116-B175#7008 |

10.2 β Series Motor Speed–Torque Curves

The curves shown below illustrate the relationship between the speed of the motor and the output torque. The motor can operate continuously at any combination of speed and torque within the prescribed continuous operating zone. The limit of the continuous operating zone is determined with the motor's ambient temperature at 40°C and its drive current as pure sine wave. The current of the servo drive unit limits actual operation.

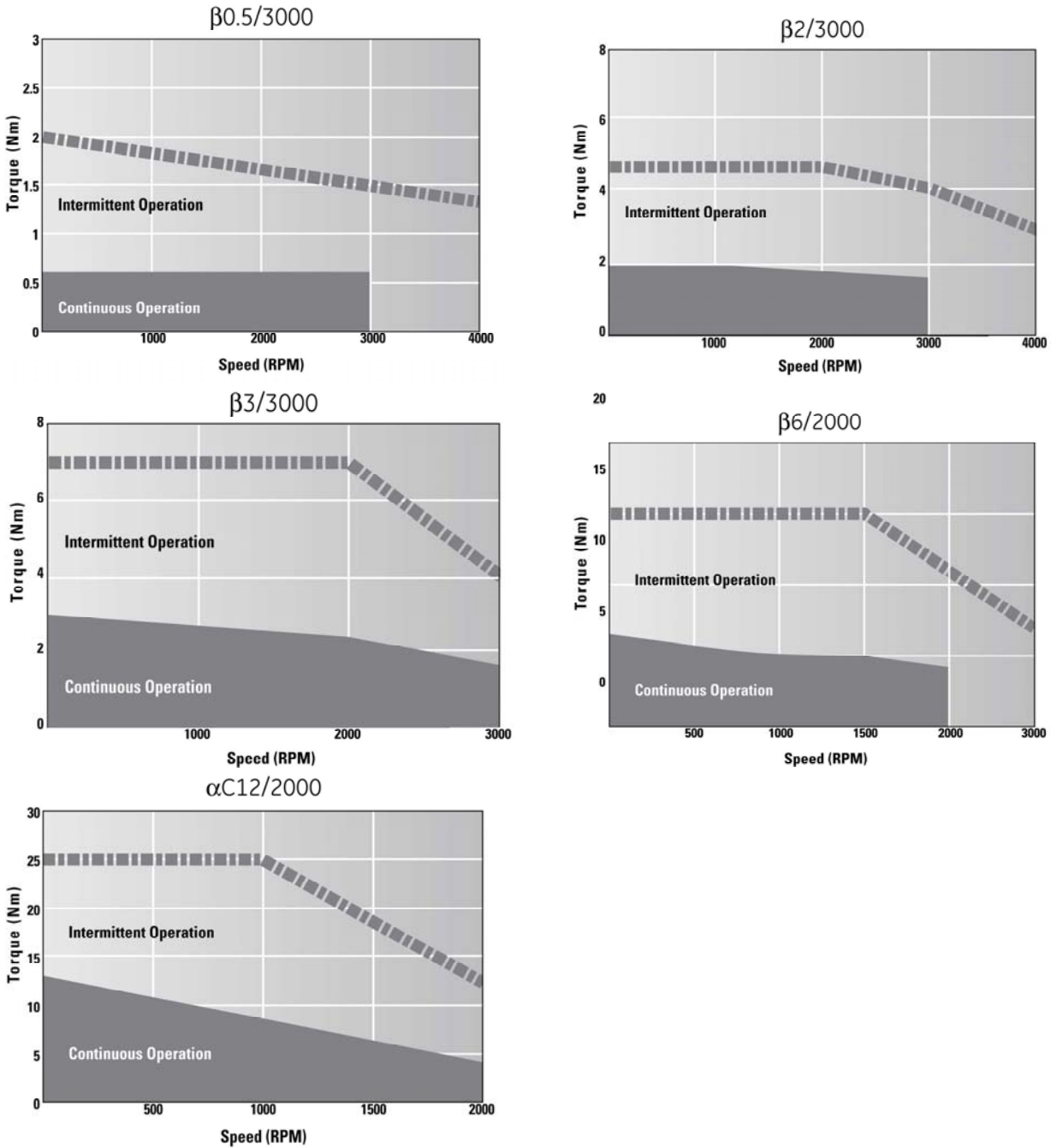

Figure II-2. β Series motor speed-torque curves

Servo Products Specification Guide

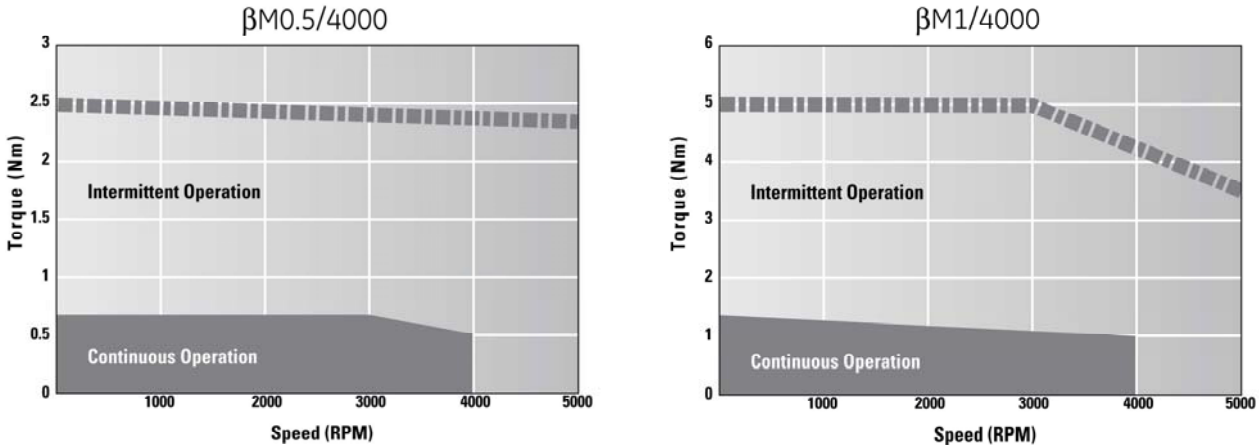

Figure II-3. βM Series motor speed-torque curves

10.3 β Series Motor Holding Brake

Any of the servo motors can be ordered with a holding brake. The brake is used to prevent movement on horizontal axes or falling along the vertical axis when the servo motor control is turned off.

Brakes are spring-set and electrically released and are designed for holding stationary loads only. Using the holding brake to stop a moving axis may damage the motor or severely reduce its service life.

The specifications of the built-in brakes are listed in Table II-2.

Table II-2. β Series Servo Motors - Brake Specifications

| Parameter | SERVO PACKAGE | | | | |
|----------------------------|---|---|---|---|--|
| | $\beta 0.5/3000$ | $\beta 2/3000$ | $\beta 3/3000$ | $\beta 6/2000$ | $\alpha C12/2000$ |
| Brake torque | 5.75 in-lb 0.65 Nm 6.6 kgf-cm | 17.7 in-lb 2 Nm 20 kgf-cm | 71 in-lb 8 Nm 82 kgf-cm | 71 in-lb 8 Nm 82 kgf-cm | 310 in-lb 35 Nm 357 kgf-cm |
| Release Response Time | 40 msec | 60 msec | 80 msec | 80 msec | 150 msec |
| Brake Response Time | 20 msec | 10 msec | 40 msec | 40 msec | 20 msec |
| Supply Voltage and Current | 90 VDC ($\pm 10\%$) 0.1 A or less | 90 VDC ($\pm 10\%$) 0.3 A or less | 90 VDC ($\pm 10\%$) 0.4 A or less | 90 VDC ($\pm 10\%$) 0.4 A or less | 90 VDC ($\pm 10\%$) 0.6 A or less |
| Weight Increase | Approx. 0.88 lb Approx. 0.4 kg | Approx. 3.3 lb Approx. 1.5 kg | Approx. 5.1 lb Approx. 2.3 kg | Approx. 5.1 lb Approx. 2.3 kg | Approx. 13.9 lb Approx. 6.3 kg |
| Inertia Increase | 0.00008 in-lb-s ² 0.00009 kg m ² 0.0009 kgf-cm-s ² | 0.00017 in-lb-s ² 0.00002 kg m ² 0.0002 kgf-cm-s ² | 0.00061 in-lb-s ² 0.00007 kg m ² 0.0007 kgf-cm-s ² | 0.00061 in-lb-s ² 0.00007 kg m ² 0.0007 kgf-cm-s ² | 0.0052 in-lb-s ² 0.0006 kg m ² 0.006 kgf-cm-s ² |

Table II-3. βM Series Servo Motors - Brake Specifications

| Parameter | SERVO PACKAGE | |
|----------------------------|--|---|
| | $\beta M0.5/4000$ | $\beta M1/4000$ |
| Brake torque | 5.75 in-lb 0.65 Nm 6.6 kgf-cm | 10.6 in-lb 1.2 Nm 12.17 kgf-cm |
| Release Response Time | 40 msec | 40 msec |
| Brake Response Time | 20 msec | 20 msec |
| Supply Voltage and Current | 24 VDC ($\pm 10\%$) 0.5 A or less | 24 VDC ($\pm 10\%$) 0.5 A or less |
| Weight Increase | Approx. 2.2 lb Approx. 1 kg | Approx. 3.3lb Approx. 1.5 kg |
| Inertia Increase | 0.00016 in-lb-s ² 0.000018 kg m ² 0.0018 kgf-cm-s ² | 0.00030 in-lb-s ² 0.000034 kg m ² 0.00034 kgf-cm-s ² |

An example of a typical **user-supplied** brake power supply is shown below:

Servo Products Specification Guide

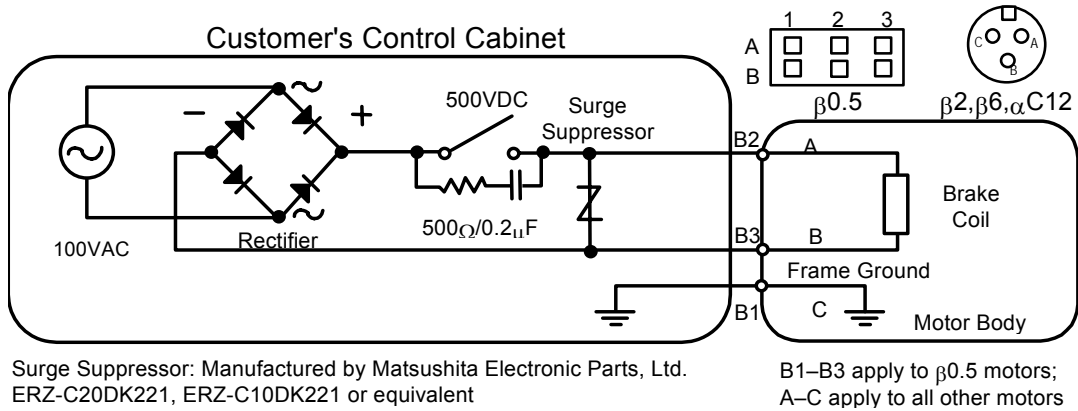

Figure II-4. Typical user-supplied brake power supply

NOTE

Use a full-wave rectified 100VAC or 90VDC as a power supply. Do not use a half-wave rectified 200 VAC, which may damage the surge suppressor. Use a rectifier with a dielectric strength of 400V or higher. Connect RC filter as shown in the above drawing to protect the contact of the switch.

10.4 β Series Servo Amplifiers

The following table shows which amplifier model is included in each β Series servo package:

Table II-4. β Series Servo Amplifier Models

| Motor | Amplifier Model | Amplifier Catalog # | Amplifier Package Catalog # |
|-------------------|-----------------|---------------------|-----------------------------|
| β 0.5/3000 | β 12 | ZA06B-6093-H101 | IC800BPK012 |
| β 2/3000 | β 12 | ZA06B-6093-H101 | IC800BPK012 |
| β 3/3000 | β 20 | ZA06B-6093-H102 | IC800BPK020 |
| β 6/2000 | β 20 | ZA06B-6093-H102 | IC800BPK020 |
| β M0.5/4000 | β 20 | ZA06B-6093-H102 | IC800BPK020 |
| β M1/4000 | β 20 | ZA06B-6093-H102 | IC800BPK020 |
| α C12/2000 | β 20 | ZA06B-6093-H102 | IC800BPK020 |

As a convenience, amplifiers can also be ordered as a package containing all of the components required to operate the amplifier in a servo system, as detailed in the following table:

Table II-5. β Series Servo Amplifier Packages

| Description | Package Contents* | Catalog # |
|---|---|-------------|
| 12 Amp β Series Amplifier Package | Contains 1 of each of the following: <ul style="list-style-type: none"> • SVU1-12 Amp (ZA06B-6093-H101) • Fuse (ZA06B-6073-K250) • Connector Kit (ZA06B-6093-K305) • E-Stop Connector (ZA02B-0120-K301) • 100 Watt Discharge Resistor (ZA06B-6093-H402) | IC800BPK012 |
| 20 Amp β Series Amplifier Package | Contains 1 of each of the following: <ul style="list-style-type: none"> • SVU1-20 Amp (ZA06B-6093-H102) • Fuse (ZA06B-6073-K250) • Connector Kit (ZA06B-6093-K305) • E-Stop Connector (ZA02B-0120-K301) • 100 Watt Discharge Resistor (ZA06B-6093-H402) | IC800BPK020 |

* If required, amplifier package components can be ordered separately.

Section 11: β Series Servo System Specifications

The β Series Servo system consists of a motor and its corresponding amplifier. GE Fanuc offers several servo systems, which are identified in Table II-6 below.

Table II-6. Identification of Servo Systems

| Parameter (Unit) | Servo System | | | | | | |
|--|--|----------------|----------------|----------------|-------------------|-----------------|-------------------|
| | $\beta 0.5/3000$ | $\beta 2/3000$ | $\beta 3/3000$ | $\beta 6/2000$ | $\beta M0.5/4000$ | $\beta M1/4000$ | $\alpha C12/2000$ |
| Motor | | | | | | | |
| Rated output power (kW) | 0.2 | 0.5 | 0.5 | 0.9 | 0.2 | 0.4 | 1.0 |
| Rated torque at stall (Nm) * | 0.6 | 2 | 3 | 6 | 0.65 | 1.2 | 12 |
| Rated torque at stall (in-lb) * | 5.3 | 17 | 26.6 | 53 | 5.8 | 10.6 | 105 |
| Rated torque at stall (kgf-cm) * | 6.1 | 20 | 30.5 | 60 | 6.61 | 12.20 | 122 |
| Rated output speed (RPM) | 4000 | 4000 | 3000 | 3000 | 4000 | 4000 | 2000 |
| Rotor inertia (kg m ²) | 0.00001764 | 0.0006566 | 0.00019 | 0.00392 | 0.00001764 | 0.000034 | 0.006272 |
| Rotor inertia (in-lb-s ²) | 0.00016 | 0.00581 | 0.017 | 0.0347 | 0.00016 | 0.00030 | 0.0555 |
| Rotor inertia (kg-cm-s ²) | 0.00018 | 0.0067 | 0.0019 | 0.040 | 0.00018 | 0.000347 | 0.064 |
| Continuous current at stall A(rms) | 2.8 | 3.2 | 5.3 | 5.6 | 3.0 | 3.0 | 5.9 |
| Torque constant (Nm/A [rms]) * | 0.23 | 0.61 | 0.56 | 1.05 | 0.2 | 0.4 | 2.04 |
| Torque constant (in-lb/A [rms]) * | 2.0 | 5.4 | 4.9 | 9.3 | 1.77 | 3.54 | 18 |
| Torque constant (kgf-cm/A [rms]) * | 2.3 | 6.2 | 5.7 | 10.7 | 2.0 | 4.1 | 20.8 |
| Back EMF constant (V/1000 RPM) * | 7.9 | 21.4 | 19.4 | 37.0 | 7.7 | 15.4 | 71 |
| Back EMF constant (Vsec/rad) * | 0.08 | 0.20 | 0.18 | 0.35 | 0.08 | 0.14 | 0.68 |
| Armature resistance (Ω) * | 0.80 | 1.4 | 0.5 | 0.85 | 0.95 | 1.55 | 1.092 |
| Mechanical time constant (s) * | 0.0007 | 0.008 | 0.009 | 0.009 | 0.009 | 0.008 | 0.005 |
| Thermal time constant (min) | 10 | 20 | 40 | 40 | 10 | 15 | 60 |
| Static friction (Nm) | 0.04 | 0.1 | 0.3 | 0.3 | 0.04 | 0.04 | 0.8 |
| Static friction (in-lb) | 0.35 | 0.89 | 2.7 | 2.7 | 0.35 | 0.35 | 7 |
| Static friction (kgf-cm) | 0.4 | 1.0 | 3.1 | 3.1 | 4.1 | 4.1 | 8 |
| Maximum allowable current (A [peak]) | 19 | 18 | 30 | 30 | 12.5 | 12.5 | 46 |
| Maximum theoretical torque (Nm) ** | 3.4 | 11 | 7 | 32 | 2.5 | 5 | 66 |
| Maximum theoretical torque (in-lb) ** | 30 | 97 | 62 | 283 | 22.1 | 44.3 | 584 |
| Maximum theoretical torque (kgf-cm) ** | 35 | 112 | 0.69 | 321 | 25 | 50.9 | 670 |
| Maximum winding temperature rise (°C) | 125 | 125 | 125 | 125 | 125 | 125 | 125 |
| Weight (kg) | 1.0 | 3.5 | 5 | 8.5 | 1 | 1.5 | 18 |
| Weight (lb) | 2.2 | 7.2 | 11 | 18.7 | 2.2 | 3.3 | 39.6 |
| Amplifier | | | | | | | |
| Model | β SVU-12 | β SVU-12 | β SVU-20 | β SVU-20 | β SVU-20 | β SVU-20 | β SVU-20 |
| Rated output current (rms amps) | 3.2 | 3.2 | 5.9 | 5.9 | 5.9 | 5.9 | 5.9 |
| Current limit (Peak amps) | 12 | 12 | 20 | 20 | 20 | 20 | 20 |
| Heat loss (watts) | 17.5 | 17.5 | 33.3 | 33.3 | 33.3 | 33.3 | 33.3 |
| AC Power | 200–240 VAC (3-phase), 220–240 VAC (1-phase) 50/60 Hz \pm 2 Hz | | | | | | |
| DC Power | 24 VDC \pm 10% @ 0.4 Amp per amplifier | | | | | | |

* These values are standard values at 20°C with a tolerance of $\pm 10\%$. The speed-torque characteristics vary, depending on the type of software, parameter setting, and input voltage of the digital servo amplifiers. (The above figures show average values.) These values may be changed without prior notice.

** Theoretical values. The actual maximum torque is restricted by the current limit values of the drive amplifier.

Section 12: β Servo System Options

Designing a servo control system requires that you understand how the electrical and mechanical aspects of your system interact. GE Fanuc application engineers are available to help you determine your servo control system requirements.

Table II-7 will help you select which servo options your system requires:

Table II-7. β Servo Package Options

| Servo Option | Consider Selecting When | Catalog # | Section # |
|--|--|--|------------------|
| Motor Holding Brake | the system design includes an axis that must hold its position when power is removed | Refer to Table II-2 | 10.3 |
| Absolute Encoder Battery Backup Kit | you would like to avoid having to re-reference the position when power is restored to the control | IC800BBK021 | 12.1 |
| AC Line Filters | 200—240 VAC is already available to the control cabinet and no transformer is used | 5.4 kW, 3-phase: ZA81L-0001-0083#3C 10.5 kW, 3-phase: ZA81L-0001-0101#C | 14.2 |
| Prefinished Cables | the cable lengths available from GE Fanuc are appropriate for your application | Refer to the “Cable Connection” Table II-22 | 15.1 |
| Discharge Resistor | see “Discharging Regenerative Power” section; The 100 Watt discharge resistor is included in all β Series Amplifier Packages | 20 Watt Resistor: ZA06B-6093-H401 100 Watt Resistor: ZA06B-6093-H402 | 14.7 |

12.1 Absolute Encoder Battery Packs

All β Series servo motors feature a built-in encoder that can be used in either incremental or absolute mode. To utilize the absolute capability, an optional encoder battery pack (IC800BBK021) for the β Series amplifier must be installed. This pack allows the encoder's position information to be backed up so that the machine does not need to be re-referenced to a home position every time power is restored to the servo system.

For optimal panel space utilization, a small lithium battery pack is available that snaps onto the underside of the β amplifier. An integral pigtail cable plugs directly into the CX5 connector. One battery is required for each amplifier.

Absolute Encoder Battery Kit (IC800BBK021) contains the following:

- Battery (ZA06B-6093-K001)
- Battery Holder (ZA06B-6093-K002)

Note: Current drain (per encoder) from battery:

- 20 μ A with amplifier power ON
- 200 μ A with amplifier power OFF

Connection Method

(for use with a single amplifier)

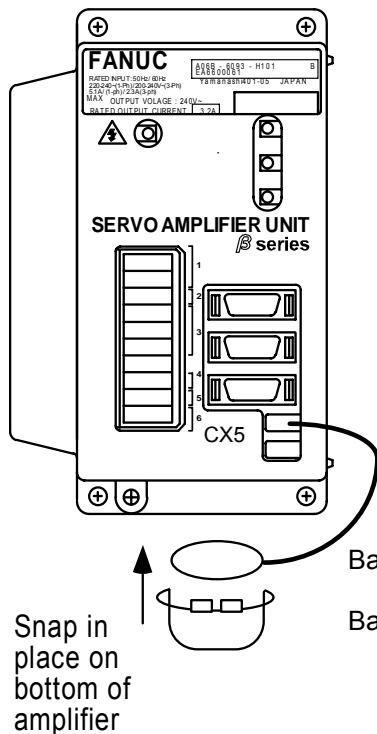

NOTE

Do not attempt to connect multiple amplifiers to one IC800BBK021 battery kit. If you wish to daisy chain multiple β Series amplifiers to one battery you must use the IC800ABK001 battery kit and the following cables:

- Z44C742433-001, battery to amplifier cable, 2m (one per battery required)
- Z44C742433-002, amplifier to amplifier cable, 250mm (one for each daisy chained amplifier required)

Figure II-5. Connecting a single β Series amplifier to an absolute encoder battery pack

Section 13: Installation Guidelines

This section includes environmental requirements, motor and amplifier dimension drawings and information on ensuring noise protection and selecting a ground fault interrupter.

13.1 Motor Environmental Requirements

The servo motor must be installed in a location that satisfies the following environmental conditions:

Table II-8. Servo amplifier environmental conditions

| Condition | Description |
|------------------------|--|
| Ambient temperature | The ambient temperature should be -10°C to 40°C. When operating the machine at a temperature higher than 40°C, it is necessary to derate the output power so that the motor's temperature rating is not exceeded. |
| Vibration | When installed in a machine, the vibration applied to the motor must not exceed 5G. |
| Altitude | No more than 1,000 m (3,300 ft) above sea level. |
| Drip-Proof Environment | The motors have a drip-proof structure that complies with IP65 of the IEC standard. Nevertheless, to ensure long-term performance, the motor surface should be protected from solvents, lubricants, and fluid spray. A cover should be used when there is a possibility of wetting the motor surface. Also, to prevent fluid from being led to the motor through the cable, put a drip loop in the cable when the motor is mounted. Finally, turn the motor connector sideways or downward as far as possible. If the cable connector will be subjected to moisture, it is recommended that an R class or waterproof plug be used. |

For additional information, see GE Fanuc publication *Servo and Spindle Motors Exposed to Liquids*, GFK-1046.

13.2 Servo Amplifier Environmental Requirements

The servo amplifier must be installed in a location that satisfies the environmental conditions identified in Table II-9 below.

Table II-9. Servo Amplifier Environmental Conditions

| Condition | Description |
|-------------------------|---|
| Ambient temperature | 0°C to 55°C (operating). -20°C to 60°C (storage and transportation). |
| Temperature fluctuation | Within 1.1°C/min. |
| Humidity | 30% to 95% RH (no condensation). |
| Altitude | No more than 1000 m (3,300 ft) above sea level. |
| Vibration | No more than 0.5 G during operation. |
| Atmosphere | The circuitry and cooling fins must not be exposed to any corrosive and conductive vapor or liquid. |

The amplifier must be installed in a cabinet that protects it from contaminants such as dust, coolant, organic solvents, acid, corrosive gas, and salt. Adequate protection must also be provided for applications where the amplifier could be exposed to radiation, such as microwave, ultraviolet, laser light, or x-rays.

Servo Products Specification Guide

To adequately protect the amplifier, you must ensure that:

- Contaminants such as dust and coolant, cannot enter through the air inlet or outlet.
- The flow of cooling air is not obstructed.
- The amplifier can be accessed for inspection.
- The amplifier can be disassembled for maintenance and later reinstalled.
- There is sufficient separation between the power and signal lines to avoid interference. Noise protection should be provided.

13.3 β Servo Amplifier heat dissipation and maintenance

The amplifier contains a cooling fan that forces air through the unit. Allow for adequate clearance for airflow when installing the amplifier using the recommended distances shown in the drawings below. If possible, do not mount amplifiers one above the other unless they are staggered to prevent the heated exhaust of the lower unit from flowing over the upper unit.

β SVU-12 Maintenance Clearances

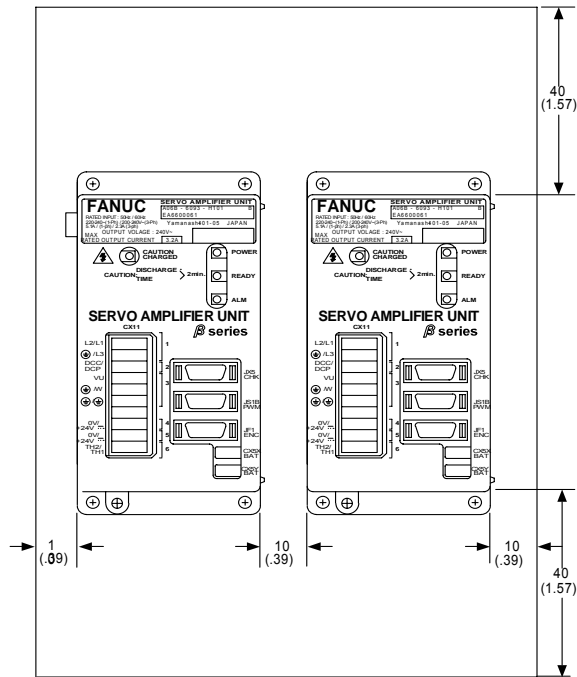

β SVU-20 Maintenance Clearances

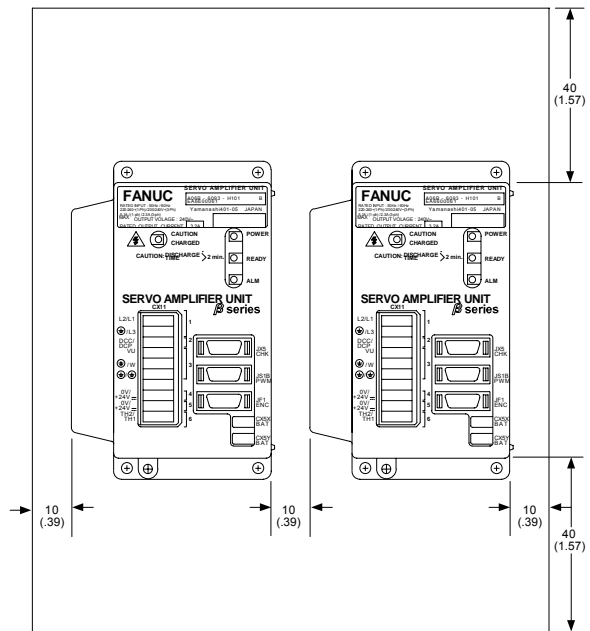

Dimensions shown in mm (in)

Figure II-6. β Series amplifier maintenance clearances

Table II-10 identifies worst-case heat dissipation values for each amplifier. These values may be used to determine heat load for sizing enclosures and cooling equipment. Heat dissipation for external regeneration resistors depends on the application and is calculated in Step 5 of “Discharging Regenerative Energy” on page II-29.

Table II-10. Heat Dissipation

| Amplifier | Total Heat Dissipation | Catalog # |
|----------------|------------------------|-----------------|
| β SVU-12 | 17.5 watts | ZA06B-6093-H101 |
| β SVU-20 | 33.3 watts | ZA06B-6093-H102 |

13.4 β and βM Series Motor Dimensions

$\beta 0.5/3000$ Motor, Front and Side Views

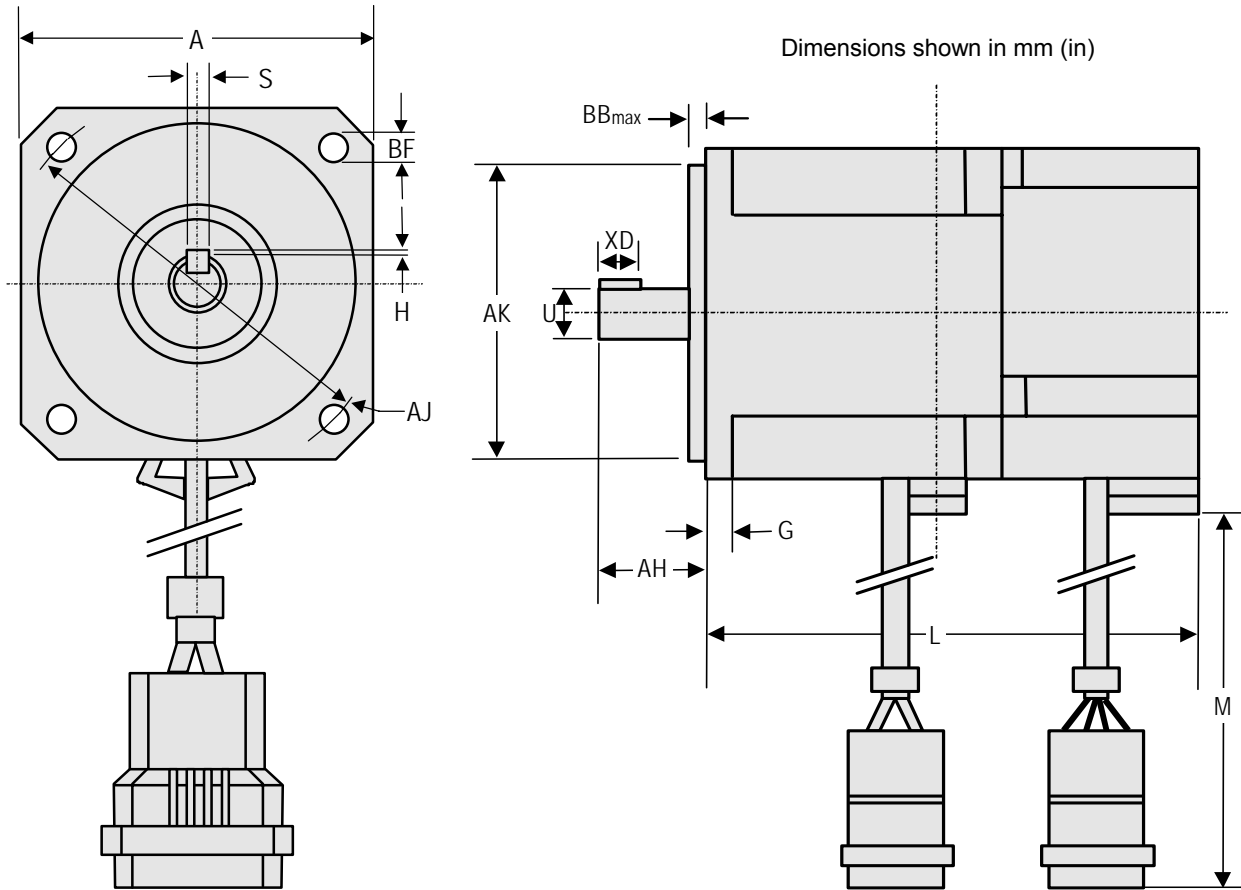

| Dim. | MOTOR |
|-----------|-------------------------------------|
| | $\beta 0.5/3000$ |
| A | 60 mm (2.36 in) |
| S | $3^{+0}_{-0.025}$ (0.1181/0.1191) |
| H | $1.2^{+0}_{-0.125}$ (0.0472/0.0423) |
| AJ (dia.) | 70 (2.76) |
| BF (dia.) | 5.5 (.2165) |

NOTES

1. Shaft diameter runout = 0.02 mm max (0.00079 in).
2. Flange surface runout = 0.06 mm max (0.00236 in).
3. Maximum radial load for output shaft is 20 kgf (44 lb).

| Dim. | MOTOR | |
|------|------------------------------------|------------------------------------|
| | $\beta 0.5/3000$ | $\beta 0.5/3000$ with brake |
| BB | 3 mm (.118 in) | 3 mm (.118 in) |
| XD | 20 (.787) | 20 (.787) |
| AK | $50^{+0}_{-0.025}$ (1.9685/1.9675) | $50^{+0}_{-0.025}$ (1.9685/1.9675) |
| U | $9^{+0}_{-0.009}$ (0.3543/0.3539) | $9^{+0}_{-0.009}$ (0.3543/0.3539) |
| G | 6 (.236) | 6 (.236) |
| AH | 25 (.984) | 25 (.984) |
| L | 100 (3.94) | 128 (5.04) |
| M | ~ 300 (11.81) | ~ 300 (11.81) |

Figure II-7. $\beta 0.5/3000$ motor, front and side views

Servo Products Specification Guide

β 2/3000, β 3/3000, β 6/2000, and α C12/2000 Motors, Front View

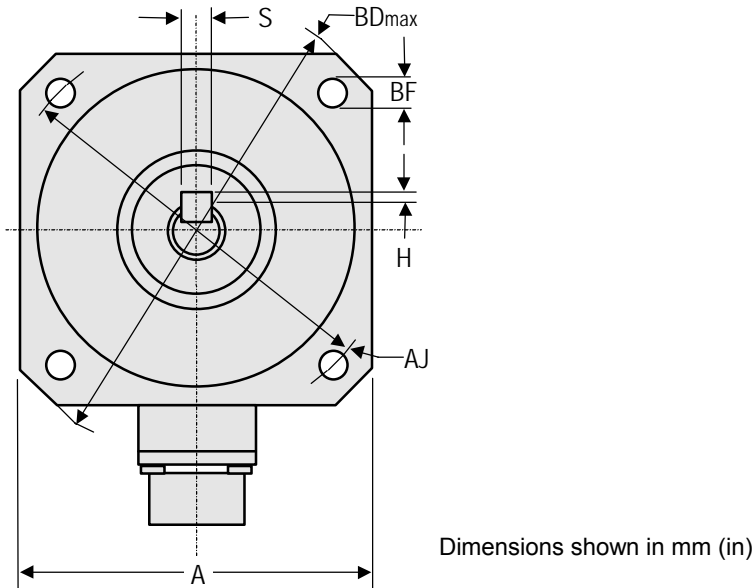

| Dimension | Motor | | | |
|-----------|--------------------------------|----------------------------------|----------------------------------|--------------------------------|
| | β 2/3000 | β 3/3000 | β 6/2000 | α C12/2000 |
| A | 105 mm (4.13 in) | 142 mm (5.59 in) | 142 mm (5.59 in) | 174 mm (6.85 in) |
| S | $5^{+0}_{-0.03}$ (.1969/.1957) | $6^{+0}_{-0.03}$ (.236/.235) | $6^{+0}_{-0.03}$ (.236/.235) | $10^{+0}_{-0.036}$ (.394/.392) |
| H | $2^{+0}_{-0.13}$ (.0787/.0736) | $2.5^{+0}_{-0.13}$ (.0984/.0933) | $2.5^{+0}_{-0.13}$ (.0984/.0933) | $3^{+0}_{-0.29}$ (.118/.107) |
| AJ (dia.) | 115 (4.53) | 165 (6.50) | 165 (6.50) | 200 (7.87) |
| BF (dia.) | 9 (.354) | 11 (.433) | 11 (.433) | 13.5 (.532) |
| BD | 134 (5.38) | 190 (7.48) | 190 (7.48) | 240 (9.45) |

NOTES FOR ALL VIEWS (see next page for side view)

1. See the β Connection section (p. 32) for more information about motor cables.
2. Shaft diameter runout = 0.02 mm max (0.00079 in) for β 2/3000, β 3/3000 and β 6/2000; 0.05 mm (0.00197 in) for α C12/2000.
3. Flange surface runout = 0.06 mm max (0.00236 in) for β 2/3000, β 3/3000 and β 6/2000; 0.10 mm (0.00394 in) for α C12/2000.
4. Maximum radial load for output shaft is 25 kgf (55 lb) for β 2/3000; 70 kgf (154 lb) for β 3/3000 and β 6/2000; 450 kgf (990 lb) for α C12/2000.

Figure II-8. β 2/3000, β 3/3000, β 6/2000, and α C12/2000 motors, front view

β 2/3000, β 3/3000, β 6/2000, and α C12/2000 Motors, Side View

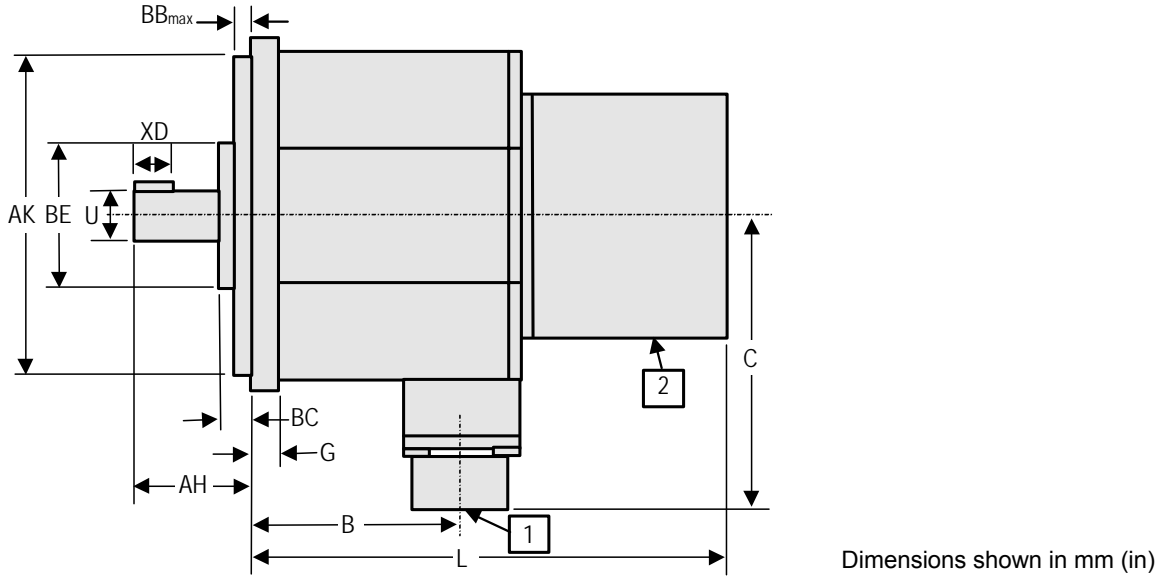

| Dimension | Motor | | | |
|-----------|--|--|--|--|
| | β 2/3000 | β 3/3000 | β 6/2000 | α C12/2000 |
| BB | 5 mm (.196 in) | 5 mm (.196 in) | 5 mm (.196 in) | 3.2 mm (.126 in) |
| XD | 20 (0.787) | 28 (1.10) | 28 (1.10) | 70 (2.76) |
| AK | 95 ⁺⁰ _{-0.035} (3.740/3.739) | 130 ⁺⁰ _{-0.035} (5.118/5.117) | 130 ⁺⁰ _{-0.035} (5.118/5.117) | 114.3 ⁺⁰ _{-0.025} (4.50/4.499) |
| U | 14 ⁺⁰ _{-0.011} (0.5512/0.5507) | 19 ⁺⁰ _{-0.013} (0.7480/0.7475) | 19 ⁺⁰ _{-0.013} (0.7480/0.7475) | 35 ^{+0.01} ₋₀ (1.3783/1.3780) |
| BC | 12 (0.472) | n/a | n/a | n/a |
| C | 88 (3.46) | 110 (4.33) | 110 (4.33) | 122 (4.80) |
| G | 8 (0.315) | 10 (0.394) | 10 (0.394) | 18 (0.709) |
| AH | 36 (1.42) | 46 (1.81) | 46 (1.81) | 79 (3.11) |
| B | 93 (3.66) | 79 (3.11) | 117 (4.61) | 166 (6.54) |
| L | 174 (6.85) | 165 (6.49) | 203 (7.99) | 240 (9.45) |
| BE | 43 (1.69) | 90 (3.54) | 90 (3.54) | N/A |

| Connector | Description |
|-----------|------------------------|
| 1 | Motor AC Power |
| 2 | Motor Encoder Feedback |

Figure II-9. β 2/3000, β 3/3000, β 6/2000, and α C12/2000 motors, side view

Servo Products Specification Guide

β 2/3000, β 3/3000, β 6/2000, and α C12/2000 Motors with Brake

(Front view same as β 2/3000, β 3/3000, β 6/2000, and α C12/2000 without brake)

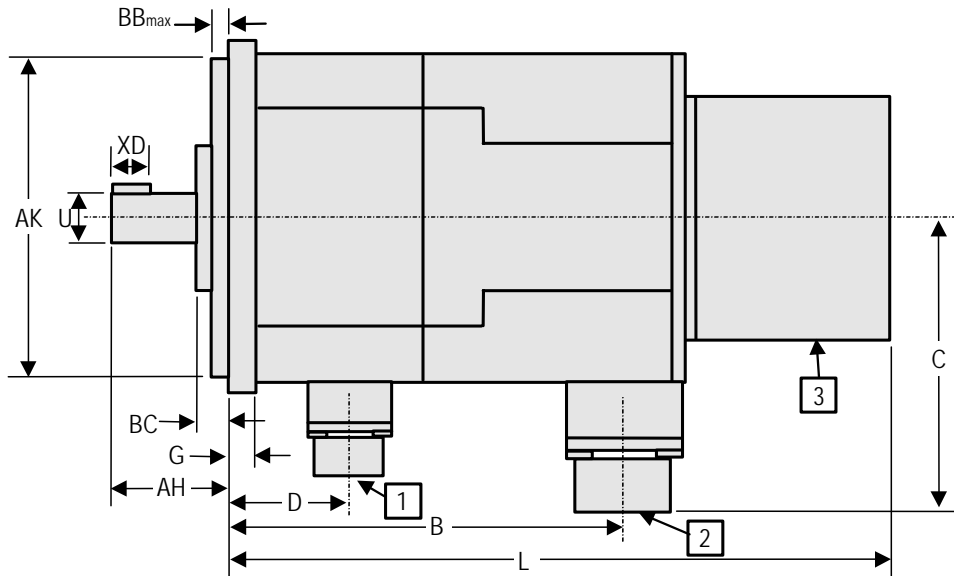

| Dimension | Motor | | | |
|-----------|--|--|--|--|
| | β 2/3000 | β 3/3000 | β 6/2000 | α C12/2000 |
| BB | 5 mm (0.196 in) | 5 mm (0.196 in) | 5 mm (0.196 in) | 3.2 mm (0.126 in) |
| XD | 20 (0.787) | 28 (1.10) | 28 (1.10) | 70 (2.76) |
| AK | 95 ⁺⁰ _{-0.035} (3.740/3.739) | 130 ⁺⁰ _{-0.035} (5.118/5.117) | 130 ⁺⁰ _{-0.035} (5.118/5.117) | 114.3 ⁺⁰ _{-0.025} (4.50/4.499) |
| U | 14 ⁺⁰ _{-0.011} (0.5512/0.5507) | 19 ⁺⁰ _{-0.013} (0.74801/0.74751) | 19 ⁺⁰ _{-0.013} (0.74801/0.74751) | 35 ^{+0.01} ₋₀ (1.37831/1.3780) |
| BC | 11 (0.433) | 10 (0.394) | 10 (0.394) | n/a |
| C | 88 (3.46) | 110 (4.33) | 110 (4.33) | 122 (4.80) |
| G | 8 (0.315) | 10 (0.394) | 10 (0.394) | 18 (0.709) |
| AH | 36 (1.42) | 46 (1.81) | 46 (1.81) | 79 (3.11) |
| D | 31 (1.22) | 28 (1.10) | 28 (1.10) | 65 (2.56) |
| B | 149 (5.87) | 131 (5.16) | 169 (6.65) | 238 (9.37) |
| L | 230 (9.06) | 217 (8.54) | 255 (10.04) | 312 (12.28) |

| Connector | Description |
|-----------|------------------------|
| 1 | Brake |
| 2 | Motor AC Power |
| 3 | Motor Encoder Feedback |

Figure II-10. β 2/3000, β 3/3000, β 6/2000, and α C12/2000 motors with brake, side view

Notes

- See the Connection section of the manual (p. 32) for more information about motor cables.
- Shaft diameter runout = 0.02 mm max (0.00079 in) for β 2/3000, β 3/3000 and β 6/2000; 0.05 mm (0.00197 in) for α C12/2000.
- Flange surface runout = 0.06 mm max (0.00236 in) for β 2/3000, β 3/3000 and β 6/2000; 0.10 mm (0.00394 in) for α C12/2000.
- Maximum radial load for output shaft is 25 kgf (55 lb) for β 2/3000; 70 kgf (154 lb) for β 3/3000 and β 6/2000; 450 kgf (990 lb) for α C12/2000.

βM0.5/4000, βM1/4000 Motor Front and Side Views

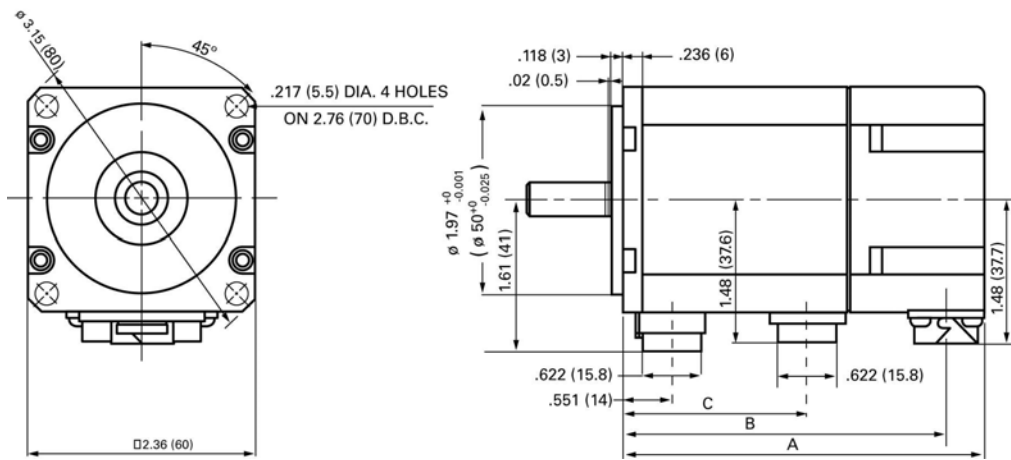

Motor

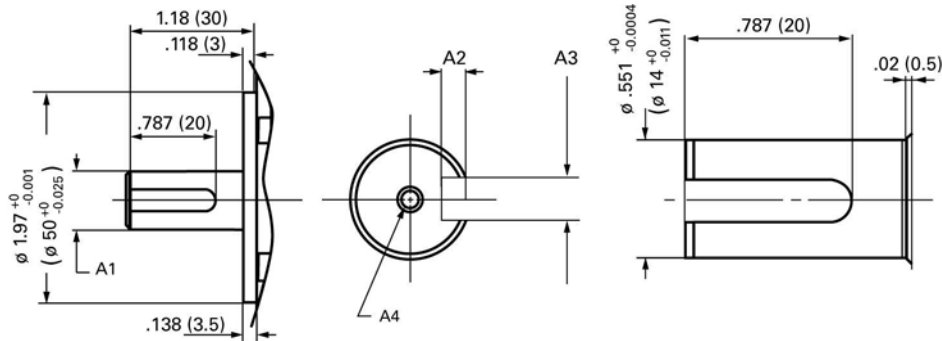

Shaft Option

| Dimension | Motor | |
|--------------|---------------------------------------|--------------------------------------|
| | βM0.5/4000 | βM1/4000 |
| A | 95.5 (3.76) | 124.5 (4.90) |
| A with Brake | 122 (4.80) | 151 (5.94) |
| A1 | $\Phi 9_{-0.0009}^0$ (0.3543/0.3539) | $\Phi 14_{-0.011}^0$ (0.5512/0.5507) |
| A2 | $1.8_{0}^{+0.1}$ (0.0748/0.0709) | $3_{0}^{+0.1}$ (0.1220/0.1181) |
| A3 | $3_{-0.029}^{-0.004}$ (0.1179/0.1169) | $5_{-0.0030}^0$ (0.1220/0.1181) |
| A4 | M3 Depth 6 | M4 Depth 10 |
| B | 85.5 (3.67) | 114.5 (4.51) |
| B with Brake | 112 (4.41) | 141 (5.55) |
| C | 49 (1.93) | 78 (3.07) |
| C with Brake | 75.5 (2.97) | 104.5 (4.11) |

Figure II-11. βM0.5/4000 and βM1/4000 motors with brake, side view

NOTES

1. Shaft diameter runout = 0.02 mm max for βM0.5/4000, βM1/4000.
2. Flange surface runout = 0.06 mm max for βM0.5/4000, βM1/4000.
3. Maximum radial load for output shaft is 20kgf (44lb) for βM0.5/4000, βM1/4000.

13.5 Shaft Loading

The allowable load of the motor shaft is as follows:

Table II-11. Allowable motor shaft load

| Motor Model | Radial Load | Axial Load | Front Bearing (type reference) |
|------------------------|--------------------|-------------------|---|
| β0.5/3000 | 20 kg (44 lb) | 5 kg (11 lb) | 6902 |
| β2/3000 | 25 kg (55 lb) | 8 kg (17.6 lb) | 6003 (without brake) 6202 (with brake) |
| β3/3000 | 70 kg (154 lb) | 20kg (44 lb) | 6205 |
| β6/2000 | 70 kg (154 lb) | 20kg (44 lb) | 6205 |
| βM0.5/4000 βM1/4000 | 20 kg (44 lb) | 5 kg (11 lb) | 6902 |
| αC12/2000 | 450 kg (990 lb) | 135 kg (297 lb) | 6208 |

NOTES:

- The allowable radial load is the value when a load is applied to the shaft end. It indicates the total continuous force applied to the shaft in some methods of mounting (for example, belt tension) and the force by load torque (for example, moment/pulley radius).
- The belt tension is critical particularly when a timing belt is used. Belts that are too tight may cause breakage of the shaft or premature bearing failure. Belt tension must be controlled so as not to exceed the limits calculated from the permissible radial load indicated above.
- In some operating conditions, the pulley diameter or gear size needs to be checked. For example, when using the model β6/2000 with a pulley/gear with a radius of 1.5 inches (3.8 cm) or less, the radial load when 230 in-lb of peak torque is provided by the motor will exceed the 154 lb maximum rating. In the case of the timing belt, the belt tension is added to this value, making it necessary to support the shaft end.
- When using a timing belt, shaft failure or bearing overload can be minimized by positioning the pulley as close to the bearing as possible.
- Since a standard single row, deep-groove ball bearing is used for the motor bearing, a very large axial load cannot be used. Particularly when using a worm gear and a helical gear, it is necessary to provide another bearing to isolate the thrust load from the gearing.
- The motor bearing is generally fixed with a C-snap ring, and there is a small play in the axial direction. When this play influences the positioning in the case of using a worm gear and a helical gear, for example, it is necessary to use an additional bearing support.

13.6 β Series Amplifiers Dimensions

The β Series amplifiers are panel mounted devices with dimensions as shown in Figure 37HII-12. When installing the amplifiers make sure the clearances as shown in Section 13.3.

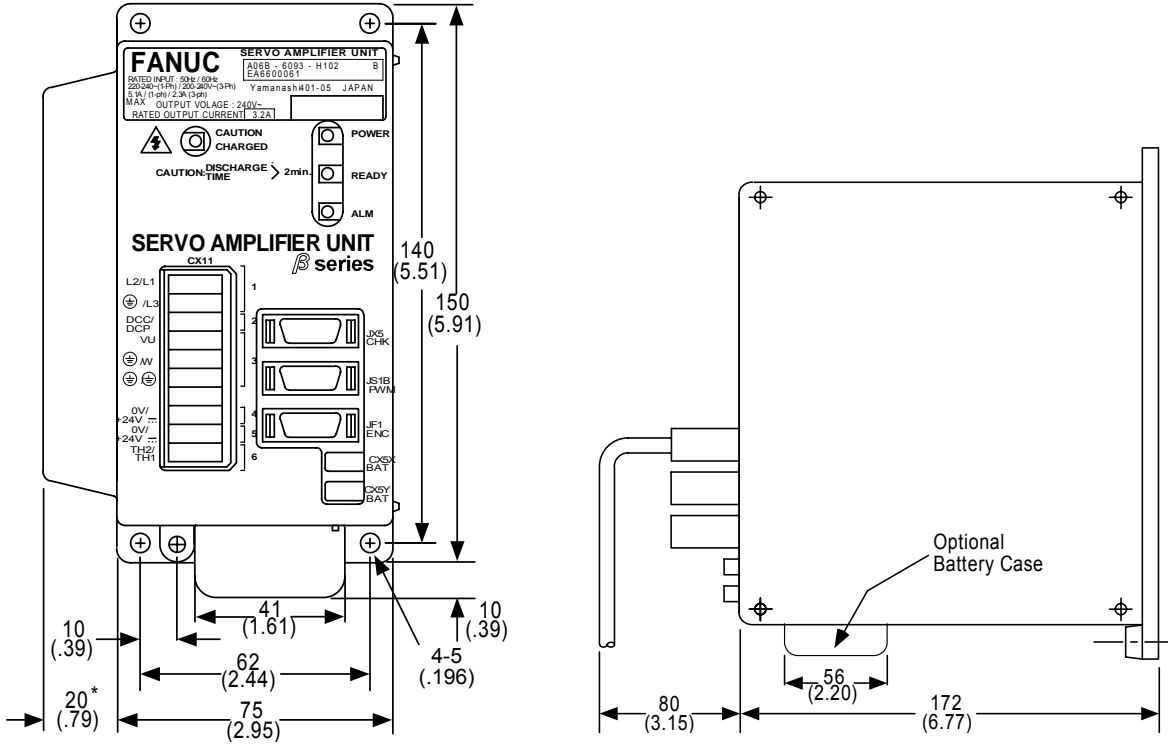

* Measurement applies to the β 20 amplifier only. The β 12 amplifier does not include the heat sink extension. Dimensions shown in mm (in).

Figure II-12. β Series servo amplifier unit, front and side views

13.7 Noise Protection

Separation of Signal and Power Lines

When routing signal and power lines, the signal lines must be separated from the power lines to ensure best noise immunity. The table below lists the types of cables used:

Table II-12. Servo amplifier signal line separation

| Group | Signal | Action |
|-------|--|---|
| A | Amplifier input power line, motor power line, MCC drive coil | Separate these cables from those of group B by bundling them separately* or by means of electromagnetic shielding**. Attach a noise preventer or suppressor, such as a spark arrester, to the MCC drive coil. |
| B | Cable connecting control unit with servo amplifier and serial encoder feedback cable | Separate these cables from those of group A by bundling them separately or by means of electromagnetic shielding**. In addition, shielding must be provided. |

* The bundle of group A cables must be separated from the bundle of group B cables by at least 10 cm.

** Electromagnetic shielding involves shielding groups from each other by means of a grounded metal (steel) plate.

Grounding

A typical machine has three separate grounds:

- **Signal Ground:** Provides the reference potential (0 V) for the electrical signal system.
- **Frame Ground:** Ensures safety and shields external and internal noise.
- **System Ground:** Connects each unit and the inter-unit frame ground system to earth ground.

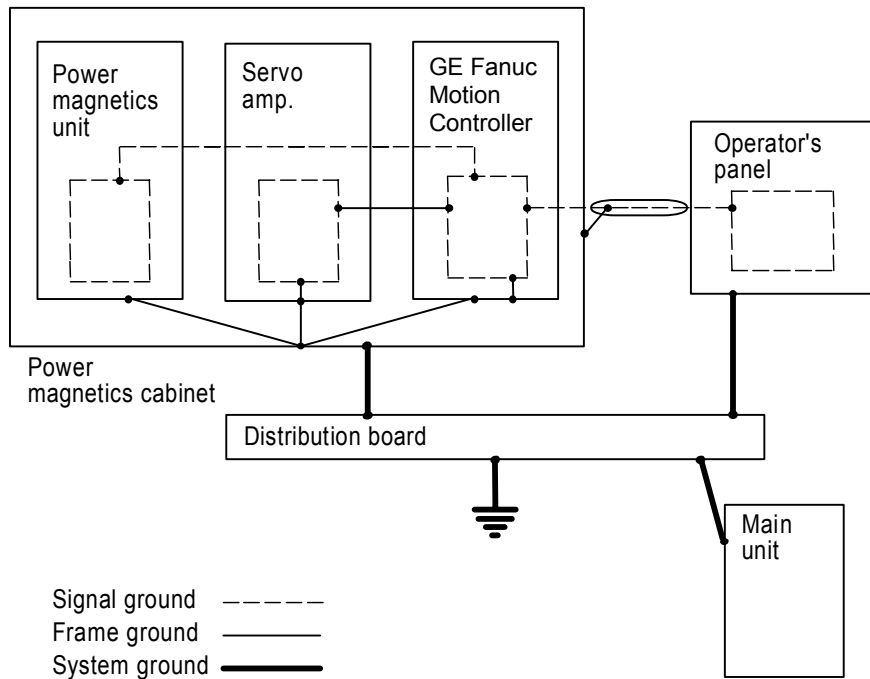

Figure II-13. Ground system

Servo Products Specification Guide

Notes on the ground system wiring:

- The ground resistance of the system ground must not exceed 100 ohms (Class-3 ground).
- System ground connection cables must have a sufficiently large cross-sectional area to enable them to safely carry the current that will arise in the event of a problem such as a short-circuit (in general, a cross-sectional area no less than that of the AC power line must be provided).
- The system ground connection cable must be integrated with the AC power line such that power cannot be supplied if the ground wire is disconnected.
- The CX11-3 grounding connector is supplied to provide the servo motor frame ground connection and should always be installed. A separate 1 meter long cable for this connection is included with the optional GE Fanuc prefinished motor power cables.
- The motor frame must be referenced to earth ground with a class 3 (100 ohms or less) system ground. Use an ohmmeter to measure the resistance from the servomotor frame to a known earth ground rod or grid. When using the 20 amp amplifier (SVM-20i), the servo motor frame ground connection on connector CZ7-3 pin A2 should always be installed. The frame-to-ground resistance should be within 1 to 2 ohms.
- In a high noise environment, installing a ground wire on the motor frame and routing it directly to the nearest available earth ground can improve noise immunity. Some servo motors have a tapped hole on the frame or a blind hole that can be tapped. For smaller motors, connect to the motor mounting bolts.
- The Motor Power cable should not be a shielded cable. If a custom built cable with shield was used for motor power, lift the shield connection at both ends of the cable. If a shield is attached, especially at the motor end, it acts as an antenna to couple noise into the encoder.
- The Motor Feedback cable should have the Z44B295864-001 Grounding Bar and one ZA99L-0035-001 Grounding Clamp per axis installed near the amplifier. Confirm that the grounding bar is referenced to earth ground with a class 3 (100 ohms or less) system ground. Use an ohmmeter to measure the resistance from the grounding bar frame to a known earth ground rod or grid. The frame to ground resistance should be within 1 to 2 ohms.

In a high noise environment, installing a ferrous bead on the feedback cable within a short distance of the amplifier connector can also improve noise immunity.

- Separation of Motor Power and Motor Feedback cables: Group A signals (Amplifier main AC power, Motor Power Cable and MCC drive coil) signals must be separated from Group B signals (Motor Feedback cable) by at least a 10cm distance. Do not tie Group A and B signals together with cable ties or wraps at any point. An alternative is to separate these two groups by means of a grounded metal (steel) plate.
- The MCC relay used to switch the three-phase AC main power to the amplifier should have an appropriate noise (spark) arrester on its drive coil.
- The 24VDC power supply used to supply the logic power to the amplifiers should be a regulated supply free of excessive noise. If possible examine the DC voltage with an oscilloscope for noise. If a 24 VDC motor-mounted holding brake is used, it should not use the same power supply as the control logic power.

Servo Products Specification Guide

- An AC line filter is recommended to suppress high frequency line noise on the amplifier main power lines. When an isolation transformer is used to convert AC main power to amplifier input power levels, the AC line filter is not required. GE Fanuc supplies an acceptable three-phase line filter sized for 5.4KW or 10.5KW especially for this purpose. This filtered AC main power should not be shared with other equipment in the panel, especially with devices such as inverter drives or motor starters that have high power consumption.
- Amplifier Chassis Ground must be referenced to earth ground with a class 3 (100 ohm or less) system ground. Use an ohmmeter to measure the resistance from the amplifier frame to a known earth ground rod or grid. A tapped and threaded hole is provided on the amplifier frame for this purpose.
- AC Main PE Ground is supplied in accordance to local code practices and may vary, depending on AC power distribution in the facility. In general the PE ground should be referenced to an earth ground and not indicate common mode voltage to the instrumentation earth ground.

13.8 Command Cable Grounding

The GE Fanuc controller cables that require shielding should be clamped by the method shown below. This cable clamp treatment provides both cable support (strain relief) and proper grounding of the shield. To ensure table system operation, the cable clamp method is recommended. Partially peel back the cable sheath to expose the shield. Push the clamp (ZA99L-0035-0001) over the exposed shield and insert the clamp hooks into slots on the grounding bar (Z44B295864-001). Tighten the clamp to secure cable and complete the ground connection. The grounding bar must be attached to a low impedance earth ground.

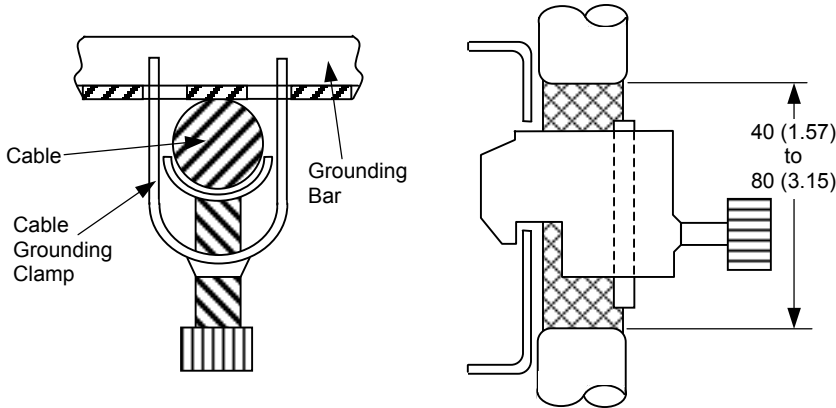

Figure II-14. Cable grounding clamp detail

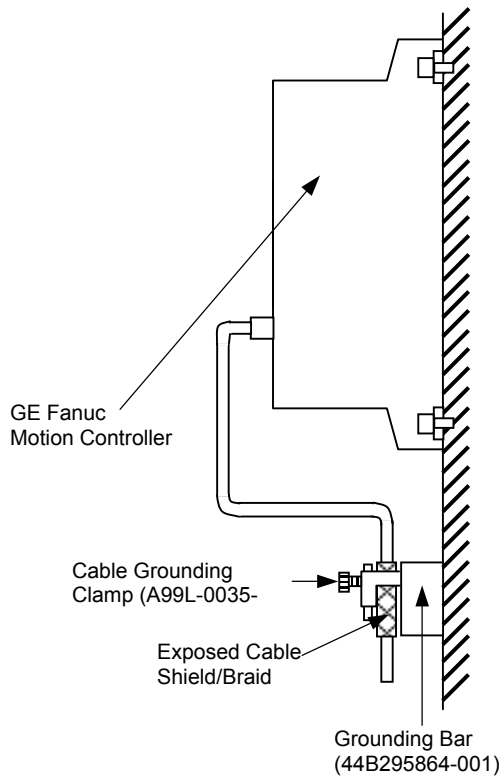

Figure II-15. Command cable shield grounding system

13.9 Selecting a Ground Fault Interrupter

The β Series servo amplifier drives a motor by means of the transistor-based PWM inverter method, in which a high-frequency leakage current flows to ground through the stray capacitance of the motor windings, power cable, and amplifier. A ground fault interrupter or leakage-protection relay, which is typically installed on the power supply side, can malfunction if such a leakage current should flow. Therefore, you should select an inverter-compatible ground fault interrupter with the following ratings to protect against the occurrence of this malfunction:

- **β 0.5/3000, β 2/3000, β 3/3000, β 6/2000, β M0.5/4000, β M1/4000:** choose a 1.8 mA commercial frequency component.
- **α C12/2000:** choose a 2.0 mA commercial frequency component.

Section 14: β Servo System Power Requirements

This section provides information about AC and DC amplifier power as well as the discharge of regenerative power.

14.1 Power Line Protection

A circuit breaker, electromagnetic contactor, and AC line filter or transformer should be installed as part of your β Series Servo system. GE Fanuc provides the AC line filter as an option. The transformer, circuit breaker, and electromagnetic contactor, however, are user-supplied components. In European countries where power sources are 380 to 400 VAC and neutral grounded, it is necessary to install a transformer or supply single-phase power.

The same incoming AC control components can be used to provide power to multiple amplifiers, as long as the components are rated for the current and power drawn by the sum of all of the amplifiers.

14.2 AC Line Filter

An AC line filter is recommended to suppress the influences of high-frequency input line noise on the drive power supply. When an isolation-type power transformer is used because a power supply voltage within the specified range is not available, an AC line filter is not required.

If two or more servo amplifiers are connected to one AC line filter, the total continuous output rating of all connected servo amplifiers should be kept below the continuous output rating of the AC line filter. The continuous output rating for the various servos are shown below.

Table II-13. β Servo Motor Continuous Output Rating

| <i>Motor</i> | <i>Cont. Output Rating</i> |
|-------------------|----------------------------|
| β 0.5/3000 | 0.2 kW |
| β 2/3000 | 0.5 kW |
| β 3/3000 | 0.5 kW |
| β 6/2000 | 0.9 kW |
| β M0.5/4000 | 0.2 kW |
| β M1/4000 | 0.4 kW |
| α C12/2000 | 1.0 kW |

If your installation must be EMC compliant, verify that the use of an AC line filter fully satisfies the EMC requirements. You may need to select and install a user-supplied noise filter to meet EMC requirements.

Two AC line filters are available:

- 5.4 kW, 3-phase (ZA81L-0001-0083#3C)
- 10.5 kW, 3-phase (ZA81L-0001-0101#C)

For AC line filter specifications and dimension drawings, refer to [Section 6.2](#).

14.3 Circuit Breaker Selection

To provide proper protection for the amplifier, use a circuit breaker rated at no more than 20 Amps (10A for VDE 1601 compliance for CE marking). Table II-14 will help you select the appropriate circuit breaker for your motion application.

Table II-14. Currents Drawn at Continuous Rated Output

| <i>Motor</i> | <i>Input Current 3-phase</i> | <i>Input Current single phase</i> |
|--------------|----------------------------------|---------------------------------------|
| β0.5/3000 | 1.9 A (rms) | 3.2 A (rms) |
| β2/3000 | 3.2 A (rms) | 5.1 A (rms) |
| β3/3000 | 3.2 A (rms) | 5.1 A (rms) |
| β6/2000 | 6.3 A (rms) | 10.1 A (rms) |
| βM0.5/4000 | 0.9A (rms) | 1.6A (rms) |
| βM1/4000 | 1.8A (rms) | 3.2A (rms) |
| αC12/2000 | 6.3 A (rms) | 10.1 A (rms) |

NOTE

When multiple amplifiers are connected to a single circuit breaker, select a breaker by multiplying the sum of the currents listed in Table II-14 by 0.6.*

Example: Connecting two β6/2000 motors operating on 3-phase power:

$$(6.3 + 6.3) \times 0.6 = 7.6 \text{ Arms}$$

A standard 10 Amp circuit breaker can be used.

During rapid motor acceleration, a peak current that is three times the continuous rating flows. Select a circuit breaker that does not trip when a current that is three times the continuous rating flows for two seconds.

*This factor attempts to compensate for applications where all axes are not demanding full power at the same time. In applications where all axes are running continuously or with high duty cycles, this factor must be increased by 1.

14.4 Electromagnetic Contactor Rating

To prepare for incoming AC power, you must also select and install an appropriate electromagnetic contactor, based on the peak currents for the motors in your system. When multiple amplifiers are connected to a single circuit breaker, select a breaker based on the sum of the currents in Table II-14.

14.5 Incoming AC Power

Table II-15. AC Power

| Specification | Description |
|--|--|
| Voltage: 3-phase 1-phase* | 200 VAC to 240 VAC 220 VAC to 240 VAC |
| Frequency | 50 Hz, 60Hz \pm 2 Hz |
| Voltage fluctuation during acceleration/deceleration | 7% or less |

* Single-phase operation reduces the lifetime of the servo amplifier. For β 6/2000 and α C12/2000 motors with acceleration/deceleration duty cycles greater than once every 20 seconds, 3-phase power is recommended.

AC Power Ratings

The power supply rating required when using multiple servo motors can be determined by summing the requirements of the individual motors.

The power supply ratings listed in Table II-16 are sufficient as continuous ratings. Note, however, that servo motor acceleration causes a current to momentarily flow that is approximately three times the continuous current rating.

When the power is turned on, a surge current of about 37A (when 264VAC is applied) flows for 20 msec.

Table II-16. Three-Phase Power Supply Ratings

| Motor | Power Supply Rating |
|-------------------|---------------------|
| β 0.5/3000 | 0.4 kVA |
| β 2/3000 | 0.77 kVA |
| β 3/3000 | 0.77 kVA |
| β 6/2000 | 1.4 kVA |
| β M0.5/4000 | 0.2 kVA |
| β M1/4000 | 0.4 kVA |
| α C12/2000 | 1.6 kVA |

14.6 Incoming DC Power

The amplifier requires a 24 VDC power supply for amplifier control power. This DC power supply must be supplied by the user.

The information in Table II-17 below will help you select the appropriate DC power supply for your motion application.

The same external DC power supply can be used to provide power to multiple amplifiers as long as the supply is rated for the sum of power drawn by all of the amplifiers. To daisy chain the amplifiers, add connection K13 between amplifiers (see the connection diagram in Section 15.3 for more details).

Table II-17. DC Amplifier Control Power Specifications

| Specification | Description |
|-------------------------------------|-----------------------|
| Input voltage | 24V DC ($\pm 10\%$) |
| Power supply rating (per amplifier) | 0.4 amps |

NOTE

The 24 VDC input is fused to protect the amplifier. The fuse labeled F600 is located below the CX11 connector when the amplifier plastic cover is removed. The replacement fuse part number is ZA06B-6073-K250 (Manufacturer: Daito LM32, DC48V, F3.2A).

A spare fuse is included with each β amplifier package (IC800BPK012 or IC800BPK020)

14.7 Discharging Regenerative Energy

Regenerative energy is normally created in applications with a high load inertia or frequent acceleration and deceleration. When decelerating a load, the stored kinetic energy of the load causes generator action in the motor causing energy to be returned to the β Series amplifier. For light loads and low acceleration rates, the amplifier may be able to absorb this energy. Otherwise, an optional external regenerative discharge unit must be installed.

Two separate 30 Ohm regenerative discharge units are available with ratings of 100 W and 20 W. The 100 W unit (ZA06B-6093-H402) is panel-mounted, whereas the 20 W unit (ZA06B-6093-H401) mounts to the tapped holes on the side of the amplifier heat sink. Calculations shown later in this section can be used to determine the need for an external unit.

If the regenerative discharge unit overheats, a built-in thermostat is tripped, the external overheat alarm is issued, and the motor is stopped. If an external regenerative discharge unit is required, a separate unit must be installed for each amplifier. This component cannot be daisy-chained. The dimensions for these units are shown in the following drawings. Connections are shown for cables K7 and K8 in Section 15.3 of this document.

Calculating the Average Regenerative Energy

Use the following calculation to determine the average regenerative energy that will be released in your application (ambient temperature is assumed not to exceed 55°C). Based on the calculations select either the 20 W or 100 W regeneration resistor. The wattage rating of the selected resistor must exceed the average calculated regenerative energy from the equation below:

$$\text{Average Regenerative Energy (Joules)} = \text{Rotational Energy to be Released during Deceleration (STEP 1)} - \text{Energy to be Consumed Through Axis Friction (STEP 2)} + \text{(only in vertical axis operation) Vertical Energy to be Released During Downward Motion (STEP 3)}$$

STEP 1: Rotational Energy to be Released during Deceleration

$$= (6.19 \times 10^{-4}) \times (J_m + J_L) \times \omega_m^2 \text{ Joules}$$

where:

| | | |
|------------|---|-------------------------|
| J_m | Motor rotor inertia | (lb-in-s ²) |
| | $\beta 0.5 = 0.00016$ | |
| | $\beta 2 = 0.00581$ | |
| | $\beta 6 = 0.0347$ | |
| | $\alpha C12 = 0.0555$ | |
| J_L | Load inertia converted to motor shaft inertia | (lb-in-s ²) |
| ω_m | Maximum motor speed at time of deceleration | (rpm) |

STEP 2: Energy to be Consumed through Axis Friction

$$= (5.91 \times 10^{-3}) \times t_a \times \omega_m \times T_L \text{ where:}$$

| | | |
|------------|--|---------|
| ω_m | Motor speed during rapid traverse | (rpm) |
| t_a | Acceleration/deceleration duration during rapid traverse | (sec) |
| T_L | Axis friction torque (converted to motor shaft torque) | (lb-in) |

STEP 3: Vertical Energy to be Released During Downward Motion

(This term applies only in vertical axis operation)

$$= (1.182 \times 10^{-2}) \times T_h \times \omega_m \times \frac{D}{100} \text{ where:}$$

| | | |
|------------|--|---------|
| T_h | Upward supporting torque applied by the motor during downward rapid traverse | (lb-in) |
| ω_m | Motor speed during rapid traverse | (rpm) |
| D | Duty cycle of downward vertical operation during rapid traverse | (%) |

(Note: the maximum value of D is 50%. D assumes a smaller value)

Servo Products Specification Guide

STEP 4: Determine if a Regenerative Discharge Unit Is Required

Determine the Average Regenerative Energy using the equation in the beginning of this section.

When the average regenerative energy produced never exceeds the amounts that is indicated in Table II-18 below, a separate regenerative discharge unit is **not** required:

Table II-18. Maximum Allowable Regenerative Energy for Amplifiers

| <i>Amplifier</i> | <i>Max. Allowable Regen. Energy</i> | <i>Used with Motors</i> |
|------------------|-------------------------------------|--------------------------|
| βSVU-12 | 13 Joules | β0.5, β2 |
| βSVU-20 | 16 Joules | β3, β6, αC12, βM0.5, βM1 |

If the calculated value exceeds the storage capability of the amplifier, then an external regenerative discharge unit is required (see Step 5).

STEP 5: Selecting a Regenerative Discharge Unit

If a separate regenerative discharge unit is required, the following calculation will determine whether the 20 W or 100 W unit is required:

Average Regenerative Power (W) = Average Regenerative Energy (Joules) $\times \frac{1}{F}$ where:

F = Deceleration duty (seconds) Example: deceleration once per 5 second cycle, F=5

Select a regenerative resistor with a rating that exceeds the average regenerative power. If this value is greater than 100 W, contact GE Fanuc for assistance.

Example:

Assume a horizontal axis using a β2 motor ($J_m = 0.00581 \text{ lb-in-s}^2$) that decelerates once every 6 seconds (F) for 0.2 seconds (t_a) with a maximum speed of 2000 RPM (ω_m). The machine inertia (J_L) is 0.0139 lb-in-s^2 .

STEP 1: Rotational Energy = $(6.19 \times 10^{-4}) \times (0.00581 + 0.0139) \times 2000^2 = 54.4 \text{ Joules}$

STEP 2: Assuming $T_L = 10 \text{ in-lb}$:

Friction Energy = $(5.91 \times 10^{-3}) \times 0.2 \times 2000 \times 10 = 23.64 \text{ Joules}$

Therefore:

STEP 4: Average Regenerative Energy = $54.4 - 23.64 = 30.76 \text{ Joules}$

Because the 30.76 Joules required is more than the 13 Joules allowed by the βSVU-12 amplifier used with the β2 motor, a regenerative resistor is required.

STEP 5: Since the application requires decelerations every 6 seconds, $\frac{1}{F} = \frac{1}{6}$

Average Regenerative Power = $30.76 \text{ Joules} / 6 \text{ seconds} = 5.13 \text{ W}$

Therefore, the 20 W resistor (ZA06B-6093-H401) is adequate for this application.

Section 15: β Servo System Connection

When planning your system, it is important to determine how the different parts of the system connect together. Cable reference numbers K1 through K15 on the β Servo Connection Diagram on p. 35. Details for each connection are shown in Section 15.3.

15.1 System Connections

β Series motor and amplifier connectors required for the system are available from GE Fanuc.

GE Fanuc supplies connectors to allow you to manufacture cables to the specific length required by your system design. GE Fanuc does offer finished cables as options for many connections. See the Cable Connections chart on p. 32 for more information.

A connector kit (Part number ZA06B-6093-K305) and an E-Stop connector (ZA02B-0120-K321) are shipped with each β Series servo amplifier package. Kit components are not sold separately. The contents of the connector kits are described below:

Table II-19. β Connector Kit Contents, ZA06B-6093-K301 (Amplifier Version G or Lower)

| Qty. | FANUC Part Number | Description | Wire Gauge |
|------|----------------------|---|---|
| 3 | A63L-0001-0460/025KD | CX11-3 (Ground), CX11-4, -5 (24 VDC) single wide connectors | NA |
| 2 | A63L-0001-0460/045KD | CX11-1 (Power), CX11-3 (Motor Power) double wide connectors | NA |
| 10 | A63L-0001-0456/ASL | CX11 contacts | 18—16 AWG (0.12mm ² —0.5mm ²) |
| 4 | A63L-0001-0456/ASM | CX11 contacts | 18—16 AWG (0.12mm ² —0.5mm ²) |
| 1 | A660-8011-T604 | CX11-6 prewired jumper for discharge resistor thermal switch (must be used when external discharge resistor is not installed) | NA |

Table II-20. β Connector Kit Contents, ZA06B-6093-K305 (Amplifier Version H or Higher)

| Qty. | Tyco Electronics AMP Part Number | Description | Wire Gauge |
|------|----------------------------------|---|--|
| 1 | 175363-3 | CX11-1 (Power) double wide connector | NA |
| 1 | 1318182-2 | CX11-2 (Dummy housing for applications when no regenerative discharge resistor is used) single wide connector | NA |
| 1 | 1318095-2 | CX11-3 (Motor Power) triple wide connector | N/A |
| 2 | 175362-1 | CX11-4 & CX11-5 (24VDC Power) two single wide connectors | N/A |
| 10 | A63L-0001-0456/ASL | CX11 contacts | 18—16 AWG (0.12mm ² —0.5mm ²) |
| 4 | A63L-0001-0456/ASM | CX11 contacts | 18—16 AWG (0.12mm ² —0.5mm ²) |
| 1 | A660-8011-T604 (FANUC p/n) | CX11-6 prewired jumper for discharge resistor thermal switch (must be used when external discharge resistor is not installed) | NA |

Servo Products Specification Guide

| |
|---------|
| Caution |
|---------|

When no regenerative discharge resistor is used, installation of a dummy housing (1318182-2) is recommended for prevention of wrong insertion. Do not make a connection between the pins (A and B) of CX11-2. Otherwise, the amplifier can be damaged.

Note: The following hand tool, which is available from Tyco Electronics (<http://www.tycoelectronics.com>), is required for installing the connectors:

Crimp Tool **58571-1** with die **58571-2** (die is installed in the tool at factory).

Optional connectors are also available for the various motor power and feedback cables.

Table II-21. Available Motor Power and Feedback Cable Connectors for β Servo Systems

| <i>Part Number</i> | <i>Description</i> |
|--------------------|--|
| ZA06B-6050-K119 | Motor Power Connector Kit, β 0.5/3000 |
| Z44A730464-G18 | Motor Power Connector Kit, β 2/3000, β 3/3000 and β 6/2000 |
| ZA06B-6050-K120 | Motor Encoder Connector Kit, β 0.5/3000 |
| ZA06B-6050-K115 | Motor Encoder Connector Kit, β 2/3000, β 3/3000 and β 6/2000 |
| ZA06B-6050-K214 | β Series Amplifier Encoder Feedback Connector Kit (JF1) |
| Z44A730464-G26 | Motor Brake Connector Kit (not required for β 0.5 motor with brake) |

Servo Products Specification Guide

Table II-22. Cable Connections

| Ref. | Connects | Prefinished Cable Part Number | Connection Type | When Required |
|------|--|---|------------------------------|---|
| K1 | DSM302 to Amplifier (JS1B) | IC800CBL001 (1m) IC800CBL002 (3m) | Servo Command Signal | always |
| K1 | All Other GE Fanuc Controllers to Amplifier (JS1B) | IC800CBL003 (2m) | Servo Command Signal | |
| K2 | Built in Serial Motor Encoder to Amplifier (JF1) | IC800CBL022 severe duty, 14m (β 0.5/3000) IC800CBL023 severe duty, 14m (β 2/3000, β 3/3000, β 6/2000) CF3A-2MPB-0140-AZ severe duty, 14m (α C12/2000) | Motor Encoder Feedback | always |
| K3 | AC Power Components to Amplifier | N/A | 3 Phase Servo Power | always |
| K4 | Amplifier to Motor (Prefinished cable includes separate cable to connect motor frame ground to customer's earth ground.) | IC800CBL067, 14m (β 0.5/3000) IC800CBL068, 14m (β 2/3000, β 3/3000, β 6/2000) CP4B-1MPB-0140-AZ, 14m (α C12/2000) | Motor Power | always |
| K5 | Servo Amplifier Emergency Stop Input (JX5) to Machine E-Stop Contact | N/A | Emergency Stop | always |
| K7 | Amplifier to Regenerative Discharge Unit | N/A (included with regenerative discharge unit) | Regenerative Power Discharge | in most cases ¹ |
| K8 | Regenerative Discharge Unit Over Temperature Switch to Amplifier | N/A (included with regenerative discharge unit) | Regenerative Power Discharge | in most cases ¹ |
| K9 | Amplifier (CX5) to Backup Battery Holder | N/A | Absolute Encoder Battery | with battery option ² |
| K10 | Control to MCC Coil | N/A | Emergency Stop/Power Enable | control-dependent; consult your control documentation |
| K12 | External 24 VDC Power Supply to Amplifier | N/A | 24 VDC Amplifier Power | always |
| K13 | Amplifier to Second Amplifier | N/A | 24 VDC Amplifier Power | when daisy chaining amplifiers |
| K14 | 90 VDC Brake Power Supply to Motor Brake | Z44C742238-004. 14m (β 2/3000, β 3/3000, β 6/2000, α C12/2000) | Motor Brake Power | with brake option ³ |
| K15 | MCC Contact to Control | N/A | Control Enable | always |

¹ See Discharging Regenerative Energy in Section 14.7

² Prefinished cable is provided as a part of a battery pack option

³ Prefinished motor power cables supplied by GE Fanuc for β 0.5/3000 motor includes brake wiring.

15.2 β Series Connection Diagram

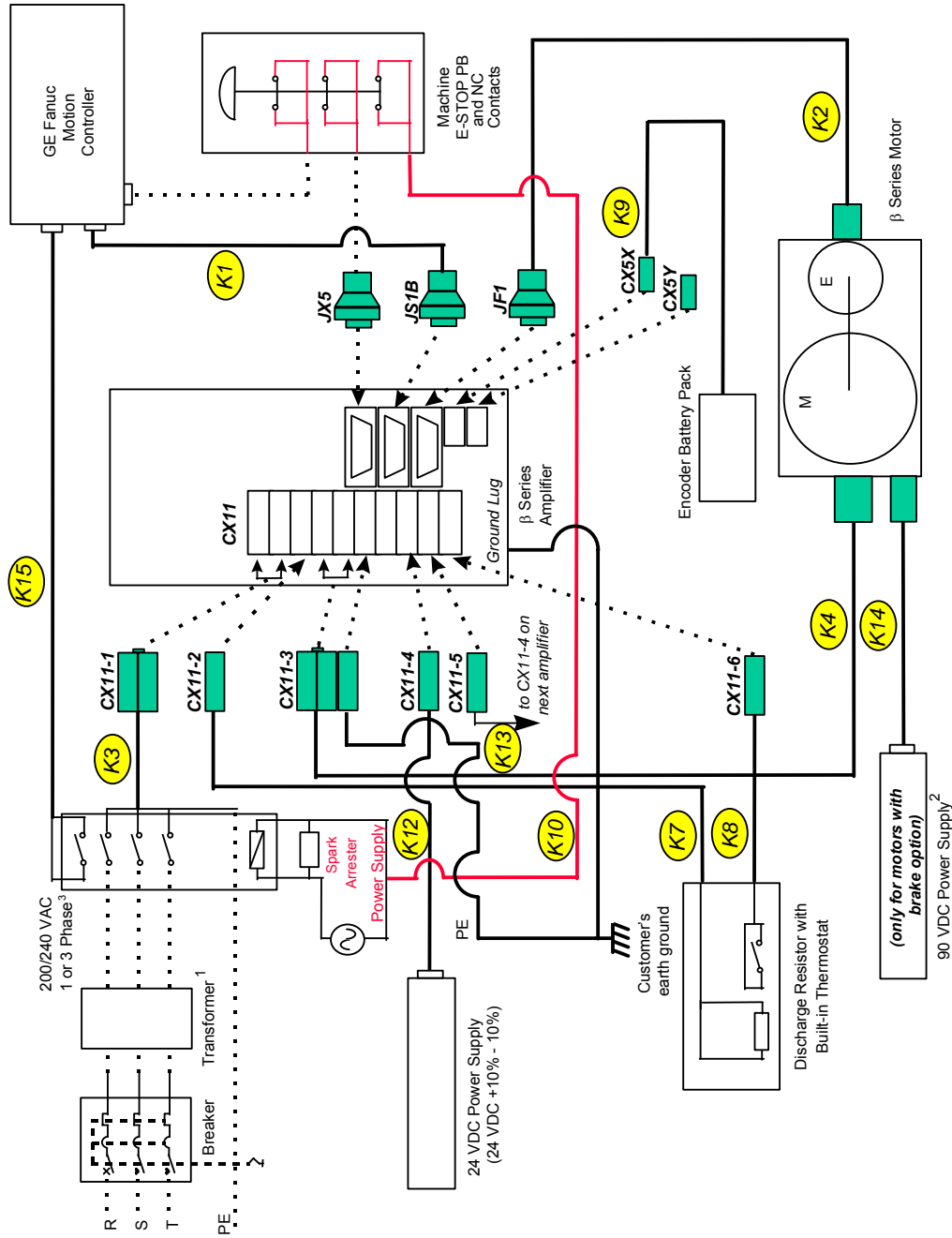

KEY:

- available GE Fanuc cable
- user-supplied cable

Figure II-16. Cable connection diagram

¹ Line filter and lightning surge absorber can be used in place of a transformer when 200–240 VAC is available to the cabinet.
² Refer to the note in Section 10.3 regarding the motor holding brake.
³ For single-phase operation, AC line phase T is not connected. Refer to the Servo System Specifications in Section 11: for output current derating.

15.3 Connection Details

K1— Servo Command Signal Cable ($\beta 0.5/3000$, $\beta 2/3000$, $\beta 3/3000$, $\beta 6/2000$, $\alpha C12/2000$)

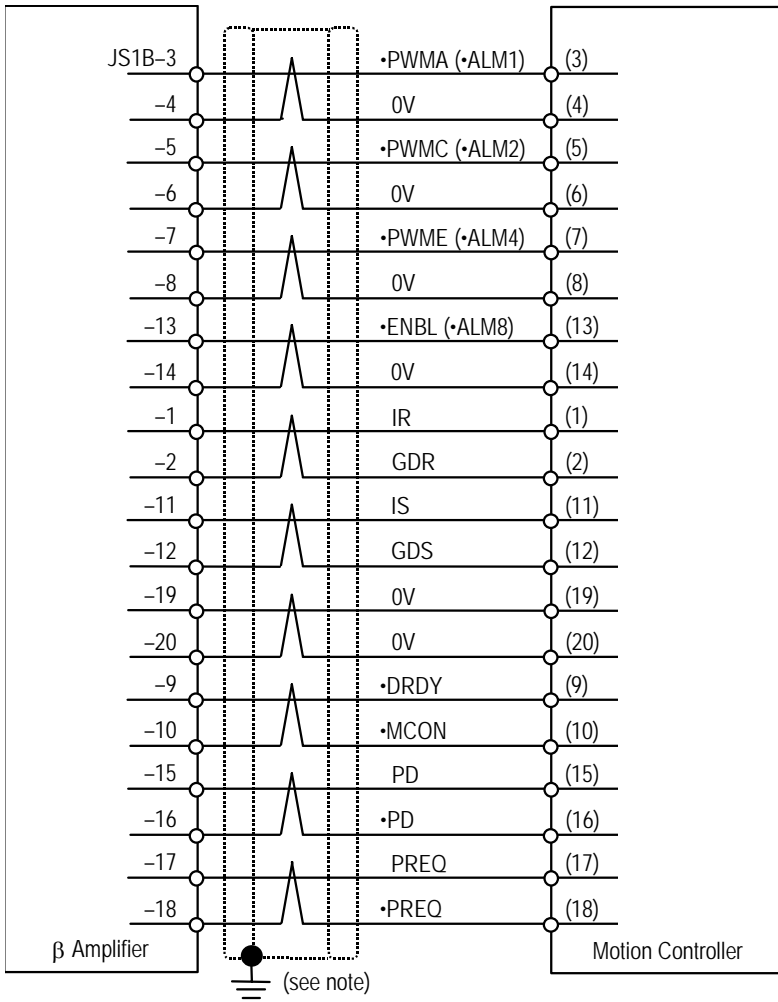

NOTES

The servo command cables for the DSM302 and DSM314 controllers (IC800CBL001 and IC800CBL002) must be purchased from GE Fanuc. Proper tooling is required to assemble the connectors. For custom length cables, contact your GE Fanuc Distributor or GE Fanuc Sales Engineer.

Grounding the cable shield using the grounding bar (Z44B295864-001) and cable grounding clamp (ZA99L-0035-0001) will provide greater noise immunity.

- Wire: 0.08mm² twisted pair group shielded cable (10 pairs). The following wire is recommended for the K1 cable: 28 AWG x 10 pairs (20 conductors).

Servo Products Specification Guide

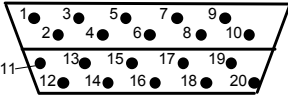
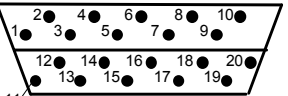
| Cable (K1) | GE Fanuc Part No. | Connector Manufacturer |
|---|--|--|
| DSM302 to Servo Amplifier (JS1B) | IC800CBL001 (1 meter) IC800CBL002 (3 meter) | Cable must be purchased from GE Fanuc (connectors not sold separately)* |
| GE Fanuc controller other than DSM302 to Servo Amplifier (JS1B) | IC800CBL003 (2 meter) | <p>Hirose Electric Co., Ltd.</p>  <p>Honda Tsushin Kogyo Co., Ltd. (PCR-E20FA)</p>  <p><i>Connectors viewed from back (solder/crimp side).</i></p> |

***NOTE:** DSM302 cables cannot be customer-manufactured and uses a 36-pin connector on its end. The DSM302 module requires IC693ACC355 Axis Terminal Board and either IC693CBL324 (1 meter) or IC693CBL325 (3 meter) Terminal Board Cable to access axis I/O such as Home Switch Input, Over Travel Inputs, or Strobe (registration) Inputs.

K2—Motor Encoder Feedback Cable (β0.5/3000)

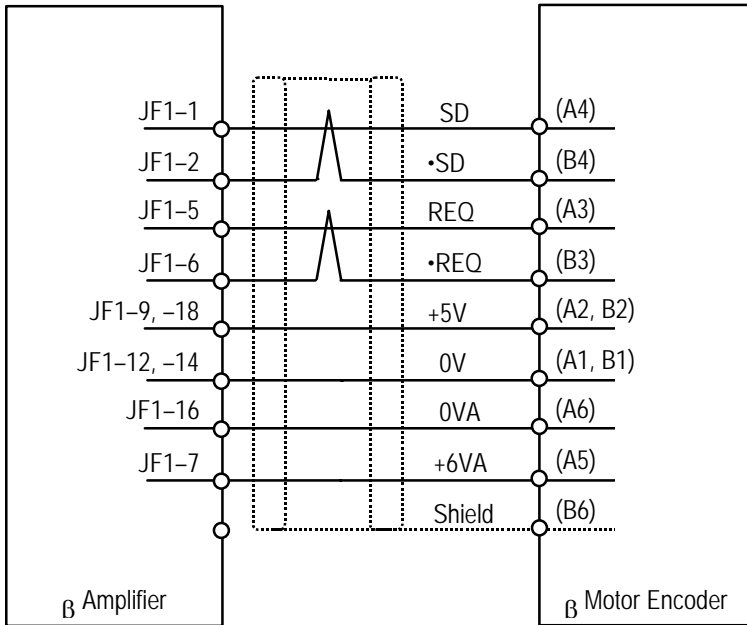

- Prefinished 14m Cable, Part number: IC800CBL022
- Wire: for +5V, 0V use two parallel conductors of 0.5mm² (20 AWG) or larger when the wire length does not exceed 14m. When the wire length exceeds 14m, wire gauge must be increased to ensure that the sum of the electrical resistance of 0V and 5V circuit does not exceed 0.5 ohms. For 6VA, 0VA use 0.5mm² (20 AWG) or larger; for SD, *SD, REQ, *REQ use 0.18mm² (24 AWG) or larger twisted pair with 60% braid shield.

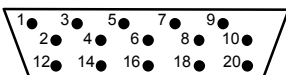
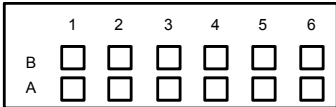
| Connector | GE Fanuc Part No. | Manufacturer |
|-----------------------|-------------------|---|
| Servo Amplifier (JF1) | ZA06B-6073-K214 | Hirose Electric Co., Ltd. (connector:FI40-2015S) (connector cover: F1-20-CV)  Connector viewed from back (solder/crimp) side. |
| Servo Motor Encoder | ZA06B-6050-K120 | AMP (connector: 178289-6 pin: AMP 1-175217-2)  |

K2—Motor Encoder Feedback Cable (β 2/3000, β 3/3000, β 6/2000)

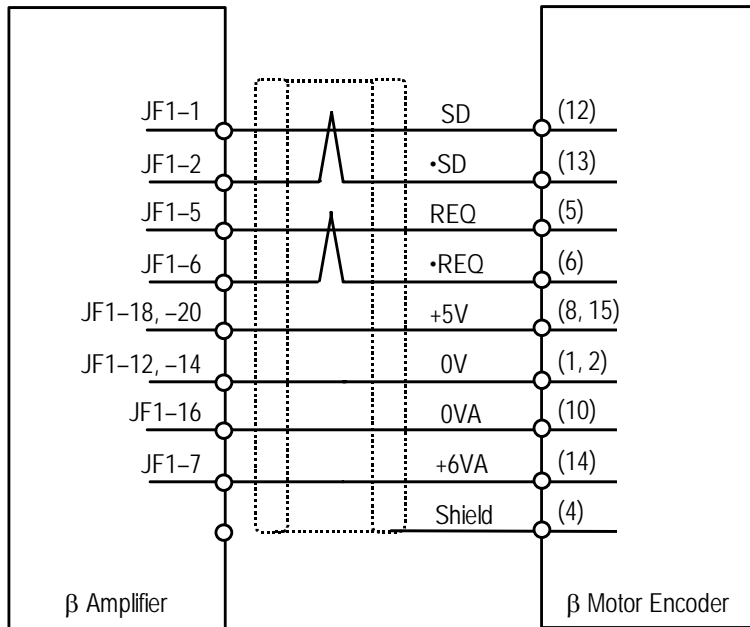

- Prefinished 14m Cable, Part number: IC800CBL023 (severe duty)
- Wire: for +5V, 0V use two parallel conductors of 0.5mm² (20 AWG) or larger when the wire length does not exceed 14m. When the wire length exceeds 14m, wire gauge must be increased to ensure that the sum of the electrical resistance of 0V and 5V circuit does not exceed 0.5 ohms. For 6VA, 0VA use 0.5mm² (20 AWG) or larger; for SD, *SD, REQ, *REQ use 0.18mm² (24 AWG) or larger twisted pair with 60% braid shield.

| Connector | GE Fanuc Part No. | Manufacturer |
|-----------------------|-------------------|--|
| Servo Amplifier (JF1) | ZA06B-6073-K214 | Hirose Electric Co., Ltd. (connector: FI40-2015S) (connector cover: FI-20-CV) |
| Servo Motor Encoder | ZA06B-6050-K115 | Hirose Electric Co., Ltd. (HDAB-15S) [connector cover: HDAW-15-CV (waterproof), HAD-CTH] |

Connectors viewed from back (solder/crimp side).

NOTE

Cable includes two M4 x 12mm screws and captive lock washers for securing connector to motor encoder housing.

K2—Motor Encoder Feedback Cable (αC12/2000)

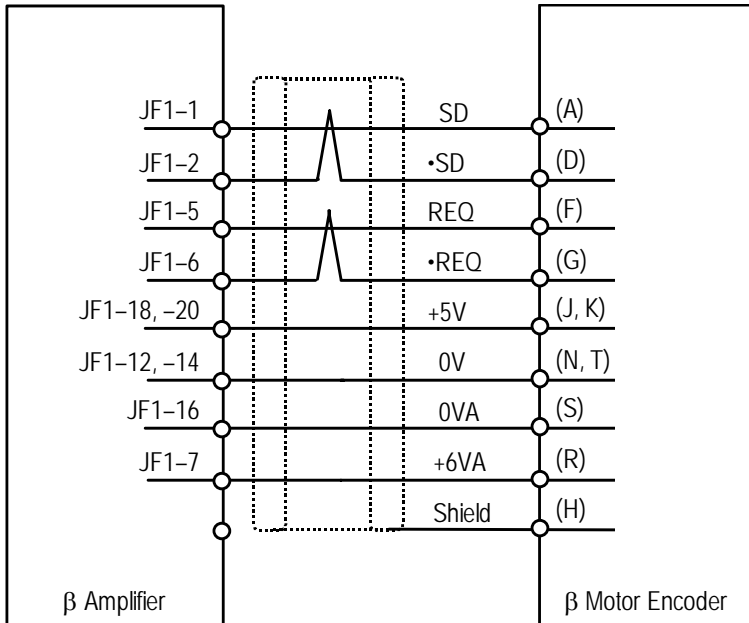

- Prefinished 14m Cable, Part number: IC800CBL021 (severe duty)
- Wire: for +5V, 0V use two parallel conductors of 0.5mm² (20 AWG) or larger when the wire length does not exceed 14m. When the wire length exceeds 14m, wire gauge must be increased to ensure that the sum of the electrical resistance of 0V and 5V circuit does not exceed 0.5 ohms. For 6VA, 0VA use 0.5mm² (20 AWG) or larger; for SD, *SD, REQ, *REQ use 0.18mm² (24 AWG) or larger twisted pair with 60% braid shield.

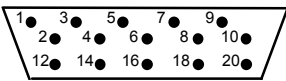
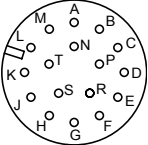
| Connector | GE Fanuc Part No. | Manufacturer |
|-----------------------|--------------------------------------|--|
| Servo Amplifier (JF1) | ZA06B-6073-K214 | Hirose Electric Co., Ltd. (F140-2015S) [connector cover: FI-20-CV]  Connector viewed from back (solder/crimp side). |
| Servo Motor Encoder | Z44A730464-G38 (CE EXT GND pin type) | Hirose Electric Co., Ltd. (MS3106A 20-29SW, straight) (MS3108B 20-29SW, elbow)  |

Servo Products Specification Guide

K3—Three-Phase Servo Power Cable (user-supplied)

For a power supply voltage of 200/220/230/240 VAC 50/60 Hz (220 VAC minimum for single-phase)

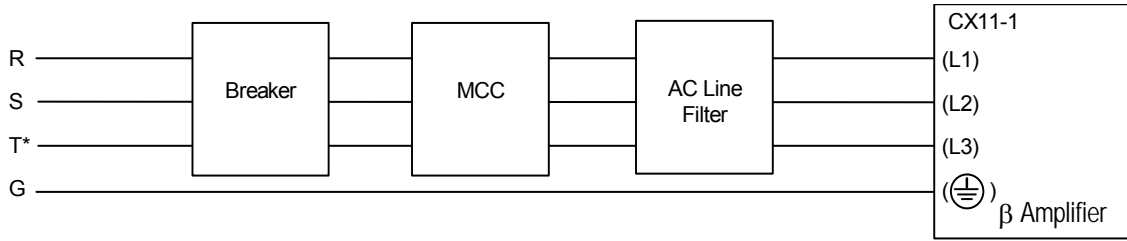

Main Power Supply

* For single-phase operation, phase T is not connected

- Wire: 600V, 4-conductor, 1.0mm² (18 AWG) or larger. For sourcing multiple amplifiers from the same AC supply, size conductors based on the sum of the current for all amplifiers (see specifications in Section 11:



| Connector | GE Fanuc Part No. | Manufacturer |
|--|--------------------------------|--|
| Servo Amplifier (Version G or lower) CX11-1 | Part of Kit ZA06B-6093-K301 | Nihon AMP (175363-1 Housing; 1-175218-2 Contact) |
| Servo Amplifier (Version H or higher) CX11-1* | Part of Kit ZA06B-6093-K305 | Nihon AMP (175363-3 Housing; 1-75218-2 Contact) |

- * The CX11-1 connector contained in the K305 kit is not compatible with β Series amplifiers prior to revision letter H.

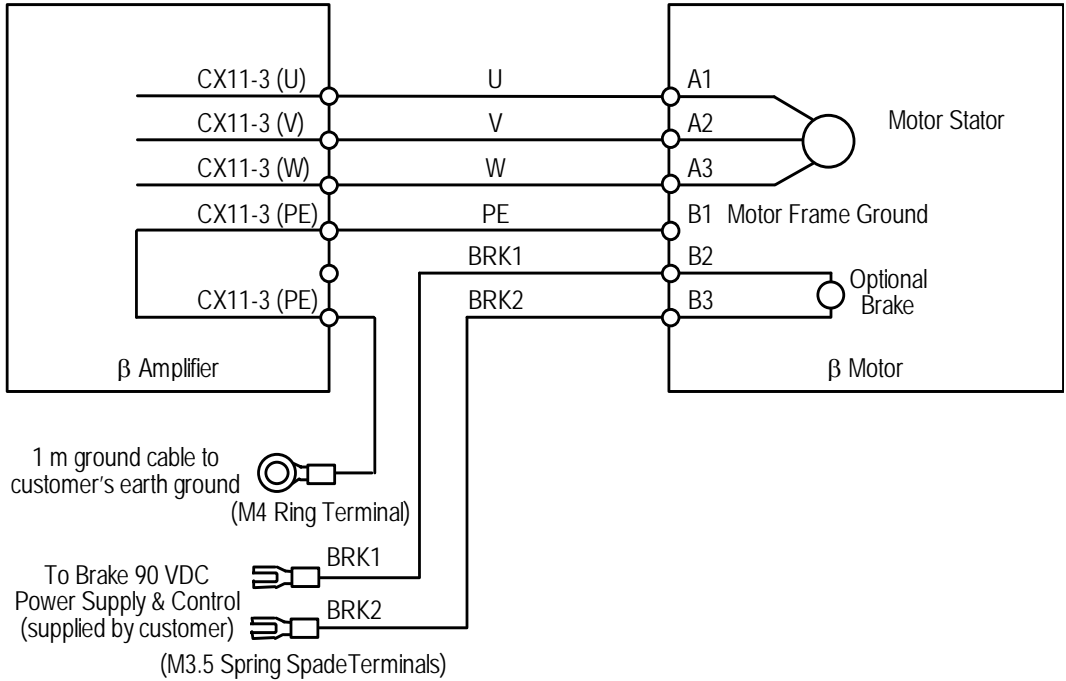
K4—Motor AC Power Cable (β0.5/3000)



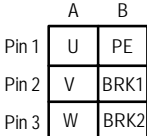

- Prefinished 14m Cable, Part number: IC800CBL064 (severe duty)
- Wire: 300V, 6-conductor, 20 AWG (finestrand) 80°C, polyurethane jacket with PVC conductors (nominal cross-sectional area 0.75mm²). Ground wire is 18 AWG, 300 V, 1-conductor, 80°C, PVC, green with yellow stripe.

| Connector | GE Fanuc Part No. | Manufacturer |
|---|--|--|
| Servo Amplifier CX11-3 (motor power) | Part of Kit ZA06B-6093-K301 (AMP version G or lower) ZA06B-6093-K305 (AMP version H or higher) | Nihon AMP (Housing: 175363-1; Contact: 1-175218-2)  |
| Servo Amplifier CX11-3 (ground) | Part of Kit ZA06B-6093-K301 (AMP version G or lower) ZA06B-6093-K305 (AMP version H or higher) | Nihon AMP (Housing: 175362-1; Contact: 1-175218-2)  |
| Servo Motor | ZA06B-6050-K119 | Nihon AMP (Housing: 3-178129-6; Contact: 1-175217-2)  |

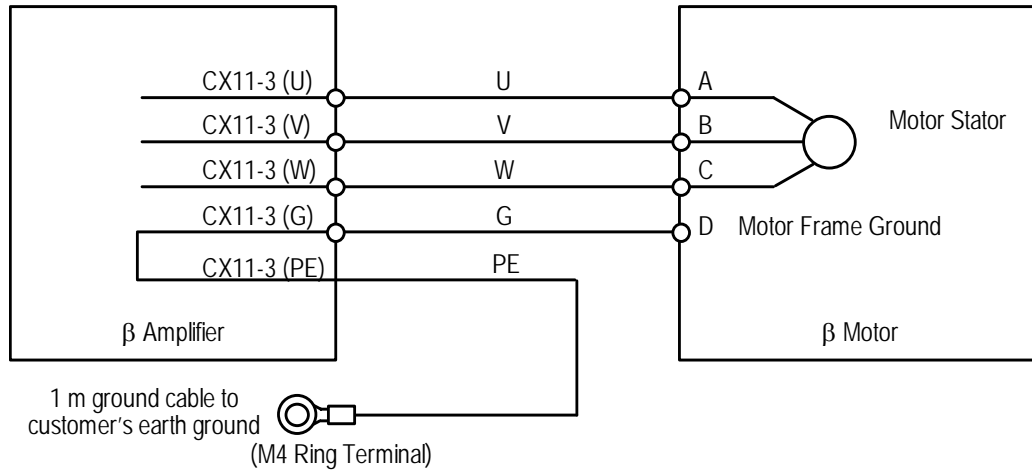
K4—Motor AC Power Cable (β 2/3000, β 3/3000, β 6/2000)



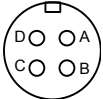

- Prefinished 14m Cable, Part number: IC800CBL065 (severe duty)
- Wire: 300V, 4-conductor, 18 AWG (finestrand) 80°C, polyurethane jacket (PUR) with PVC conductors (nominal cross-sectional area 0.75mm²). Ground wire is 18 AWG, 300 V, 1-conductor, 80°C, PVC, green with yellow stripe.

| Connector | GE Fanuc Part No. | Manufacturer |
|---|--|--|
| Servo Amplifier CX11-3 (motor power) | Part of Kit ZA06B-6093-K301 (AMP version G or lower) ZA06B-6093-K305 (AMP version H or higher) | Nihon AMP (Housing: 175363-1; Contact: 1-175218-2)  |
| Servo Amplifier CX11-3 (ground) | Part of Kit ZA06B-6093-K301 (AMP version G or lower) ZA06B-6093-K305 (AMP version H or higher) | Nihon AMP (Housing: 175362-1; Contact: 1-175218-2)  |
| Servo Motor | Customer-made cable: Z44A730464-G18 (CE EXT GND pin) |  |

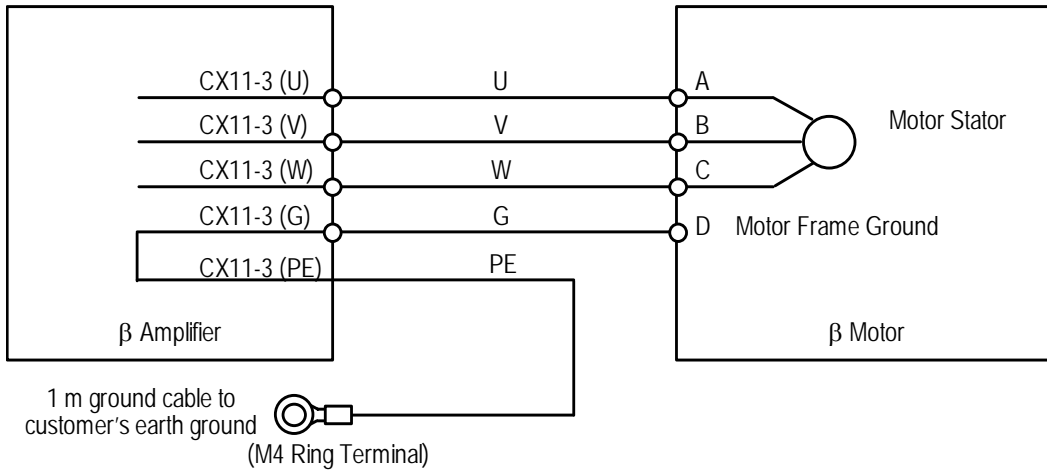
K4—Motor AC Power Cable (αC12/2000)



- Prefinished 14m Cable, Part number: IC800CBL066
- Wire: 300V, 4-conductor, 18 AWG (finestrand) 80°C, polyurethane jacket with PVC conductors (nominal sectional area 0.75mm²). Ground wire is 18 AWG, 300 V, 1-conductor, 80°C, PVC, green with yellow stripe.

| Connector | Part No. | Maker |
|---|--|---|
| Servo Amplifier CX11-3 (motor power) | Part of Kit ZA06B-6093-K301 (AMP version G or lower) ZA06B-6093-K305 (AMP version H or higher) | Nihon AMP (Housing: 175363-1; Contact: 1-175218-2)  |
| Servo Amplifier CX11-3 (ground) | Part of Kit ZA06B-6093-K305 (AMP version G or lower) ZA06B-6093-K305 (AMP version H or higher) | Nihon AMP (Housing: 175362-1; Contact: 1-175218-2)  |
| Servo Motor | Customer-made cable: Z44A730464-G20 (CE EXT GND pin) |  |

Servo Products Specification Guide

K5—Servo Amplifier Emergency Stop Connection

If two to six amplifier units are used in the same system, the emergency stop signal must be connected as shown below:

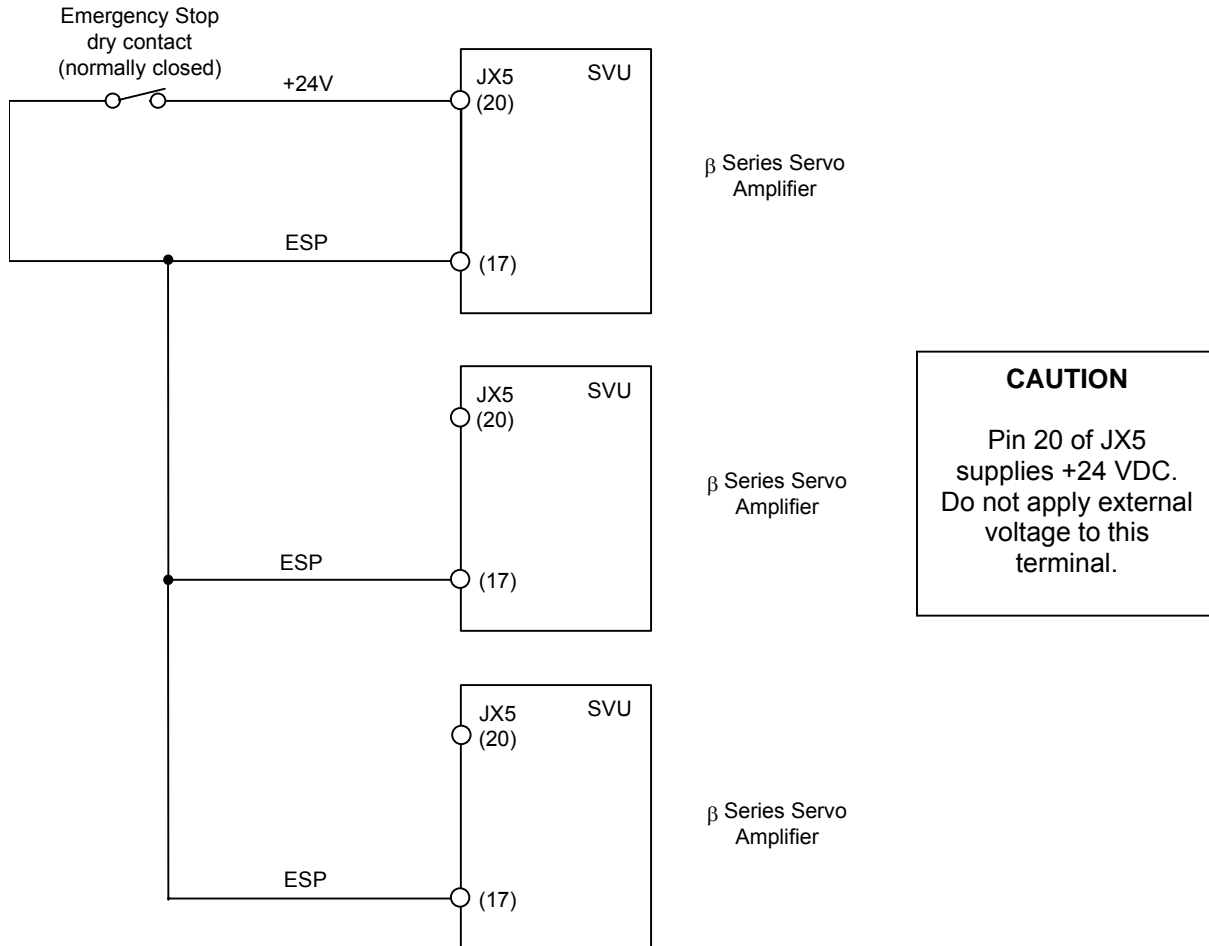

| Connector | GE Fanuc Part No. | Manufacturer |
|-----------|-------------------|--|
| JX5 | ZA02B-0120-K301 | <p>Hirose Electric Co., Ltd. (F140-2015S; F1-20-CV cover)</p> <p>Honda Tsushin Kogyo Co., Ltd. (PCR-E20FA)</p> <p>Connectors viewed from back (solder/crimp side).</p> |

K7—Regenerative Power Discharge Cable (β 2/3000, β 3/3000, β 6/2000, α C12/2000)
K8—Regenerative Power Discharge Thermal Protection Cable

(Resistor includes amplifier connectors and contacts)

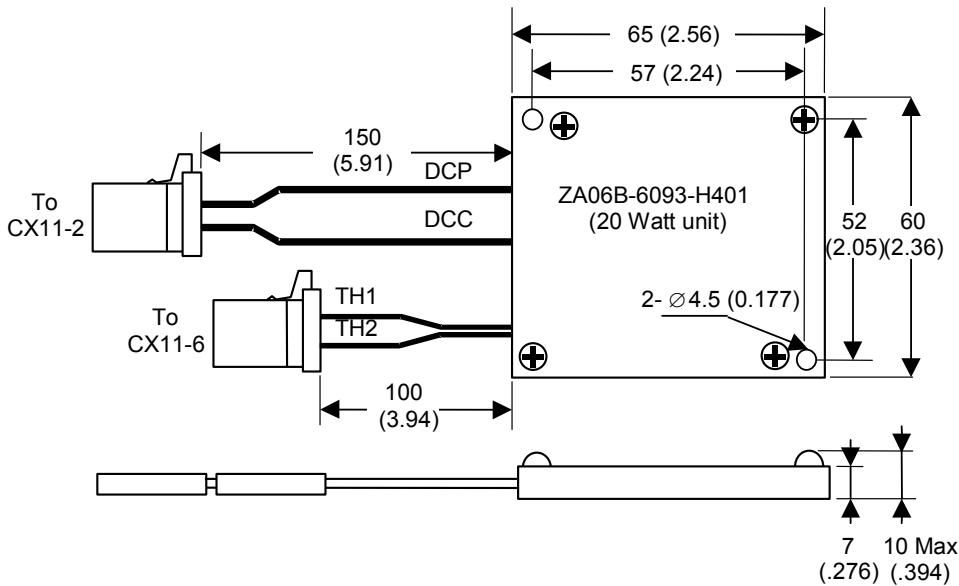
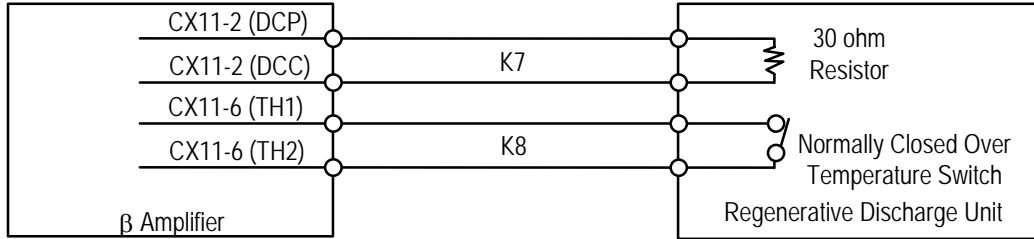

NOTE
Resistor kit contains two standoffs and mounting hardware

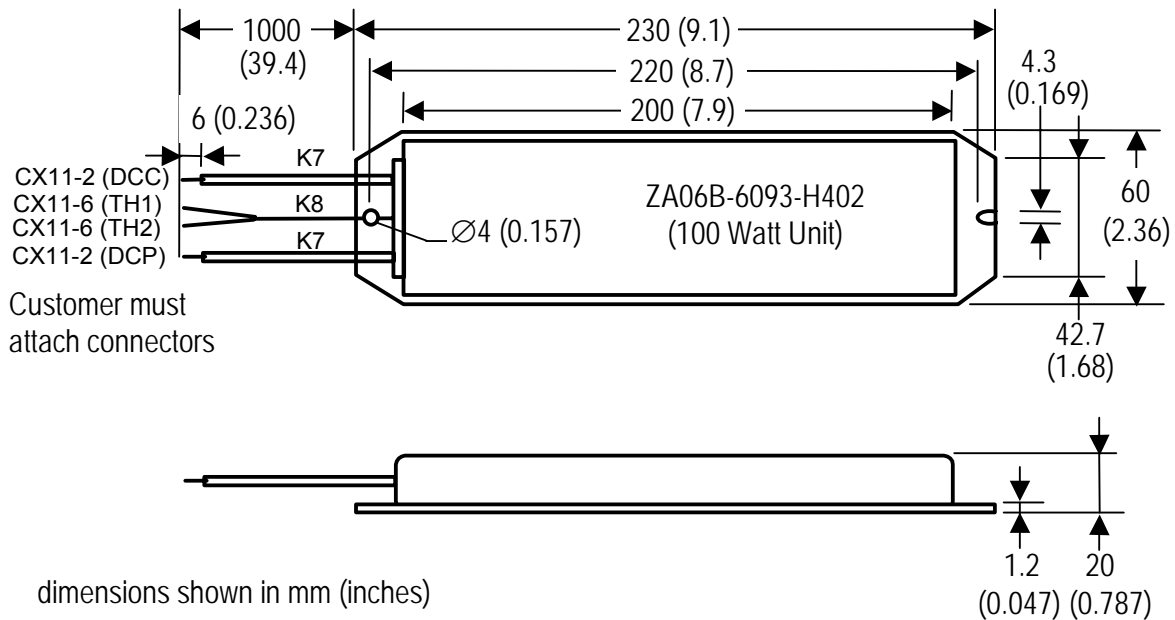

dimensions shown in mm (inches)

Servo Products Specification Guide

| Connector | GE Fanuc Part No. | Manufacturer |
|-------------------------------|-------------------------------|---|
| Servo Amplifier CX11-2, -6 | Included with Resistor Kit | Nihon AMP (Housing: 175362-1; Contact: 1-175218-2) <div style="display: flex; justify-content: space-around; align-items: center;"> <div style="text-align: center;"> <div style="border: 1px solid black; width: 15px; height: 15px; margin: 0 auto 5px auto;"></div> <div style="border: 1px solid black; padding: 2px;">DCP</div> <div style="border: 1px solid black; padding: 2px;">DCC</div> </div> <div style="text-align: center;"> <div style="border: 1px solid black; width: 15px; height: 15px; margin: 0 auto 5px auto;"></div> <div style="border: 1px solid black; padding: 2px;">TH1</div> <div style="border: 1px solid black; padding: 2px;">TH2</div> </div> </div> |

K9—Absolute Encoder Battery Cable (β 0.5/3000, β 2/3000, β 3/3000, β 6/2000, α C12/2000)

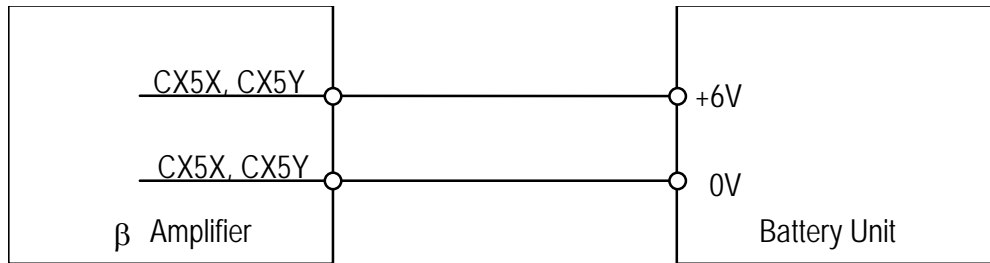

- Wire: Nominal sectional area 0.32mm² (24 AWG) or less

| Connector | GE Fanuc Part No. | Manufacturer |
|---------------------------|-------------------|--|
| Servo Amplifier (CX5X) | ZA06B-6093-K303 | Japan Aviation Electronics Industry (Housing: IL-L2S-S3L-B(N); Contact: IL-C2-1-00001) |

K10—Emergency Stop/Power Enable Cable ($\beta 0.5/3000$, $\beta 2/3000$, $\beta 3/3000$, $\beta 6/2000$, $\alpha C12/2000$)

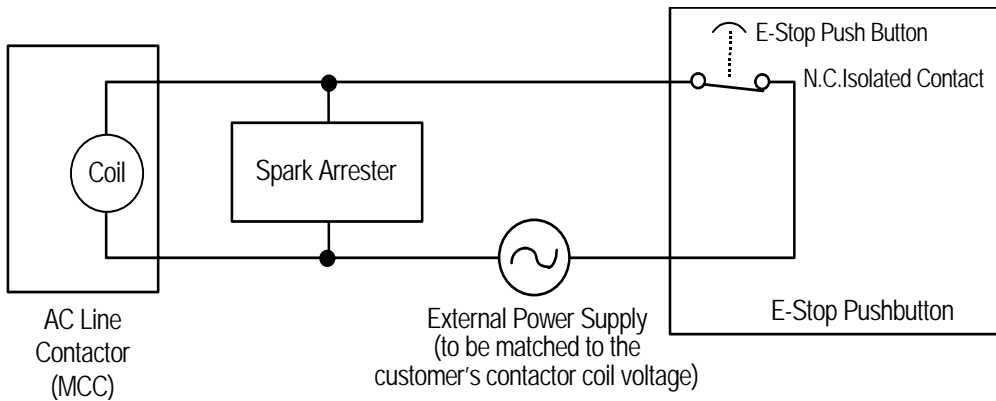

- Cable Specification: Heavy-duty vinyl power cord, 2-conductor 0.5mm² (20 AWG)
- Spark Arrester: To protect internal contacts, always use a spark arrester appropriate for the contactor you select.

K12—24 VDC Amplifier Power Cable ($\beta 0.5/3000$, $\beta 2/3000$, $\beta 3/3000$, $\beta 6/2000$, $\alpha C12/2000$)

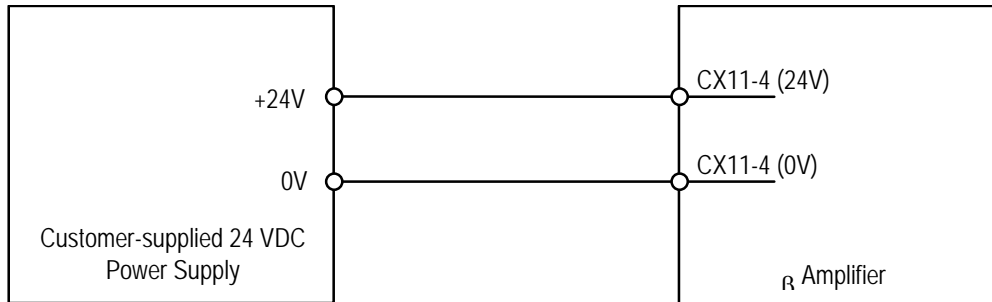

- Wire: Nominal sectional area 0.5mm² (20 AWG)

| Connector | GE Fanuc Part No. | Manufacturer |
|------------------------|--|---|
| DC Power Supply | N/A | N/A |
| Servo Amplifier CX11-4 | Part of Kit ZA06B-6093-K301 (AMP version G or lower) ZA06B-6093-K305 (AMP version H or higher) | Nihon AMP (Housing: 175362-1; Contact: 1-175217-2) |

Servo Products Specification Guide

K13—24 VDC Amplifier Power Daisy Chain Cable ($\beta 0.5/3000$, $\beta 2/3000$, $\beta 3/3000$, $\beta 6/2000$, $\alpha C12/2000$)

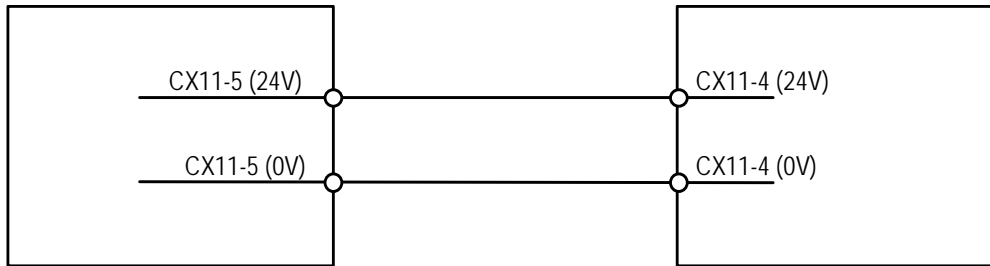

- Wire: Nominal sectional area 0.5mm² (20 AWG)

| Connector | GE Fanuc Part No. | Manufacturer |
|---------------------------|--|---|
| DC Power Supply | N/A | N/A |
| Servo Amplifier CX11-5 | Part of Kit ZA06B-6093-K301 (AMP version G or lower) ZA06B-6093-K305 (AMP version H or higher) | Nihon AMP (Housing: 175362-1; Contact: 1-175217-2) |

K14—Motor Brake Power Cable ($\beta 2/3000$, $\beta 3/3000$, $\beta 6/2000$, $\alpha C12/2000$)

($\beta 0.5/3000$ brake wiring is include in power cable K4)

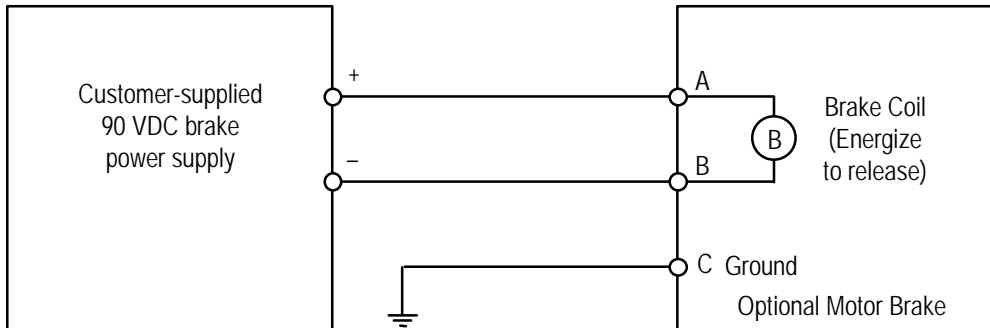

- Prefinished 14m Cable, Part number: Z44C742238-004 (severe duty)
- Wire: 300V, 3-conductor, 20 AWG (0.5mm²), finestrand, 80 °C, polyurethane (PUR) jacket

| Connector | GE Fanuc Part No. | Manufacturer |
|------------------|---|--|
| Motor Brake | Customer-made cable: Z44A730464-G26 GE Fanuc cable: Z44A739012-G08 | DDK CE Series (CE02-6A10SL-3CS) with Raychem Boot (222A-32-25142)  |

15.4 β Series Amplifier Protection and Alarm Functions

The Servo Amplifier Unit can detect error conditions and provide alarm information.

The LEDs on the front of the amplifier provide a visual cue to the status of the system by indicating, for example, when the motor and amplifier are ready to function. The ALM LED is turned ON when an alarm condition is detected. When an alarm is detected, power is dropped and the motor is stopped by dynamic braking action. Alarm information is displayed as diagnostic data in the GE Fanuc controller. Table II-23 details the alarm conditions the β Series Servo Amplifier System can detect.

Table II-23. β Series Servo Amplifier Alarm System

| <i>Alarm Condition</i> | <i>Description</i> |
|-------------------------------|--|
| Over-voltage | Issued when the DC voltage in the main circuit power supply is abnormally high. |
| DC link under-voltage | Issued when the DC voltage in the main circuit power supply is abnormally low or when the circuit breaker has tripped. |
| Regenerative overheat | Issued when the average regenerative discharge energy is excessively high, such as when acceleration/deceleration is performed too frequently. |
| Overheat | Issued when the temperature inside the amplifier becomes so high that the thermostat trips. |
| Fan failure | Issued when the fan unit built into the amplifier fails. |
| Over-current | Issued when an abnormally high current is detected in the main circuit. |

Part III:
 β_i and β_{HVi}
Series Servo
Systems

Section 16: β i and β HVi Series Servos Overview

16.1 β i and β HVi Series Servo Systems

β is Series servomotors are high performance, low inertia servomotors with built-in serial encoders. All β is Series servomotors are available with an optional 24VDC holding brake. Each β is Series servomotor must be used with the designated amplifier and a GE Fanuc DSM324i motion controller.

Table III-1 provides a summary of β is Series servo motors. See Section 18: for more detailed motor specifications.

Table III-1. β is Series Servo Systems (230 VAC Main Power)

| <i>Motor</i> | <i>Rated Torque</i> | <i>Encoder</i> | <i>Required Amplifier</i> | <i>Motor Catalog #</i> |
|----------------------------|--|----------------------|--|--|
| β 0.4/5000 <i>is</i> | 0.4 Nm (3.5 lbf-in) continuous stall torque; 5000 RPM | β 64ia (64K) | β SVM1-20i ZA06B-6130-H002 | Motor Only: ZA06B-0114-B203 Motor w/ Brake: ZA06B-0114-B503 |
| β 0.5/6000 <i>is</i> | 0.65 Nm (5.8 lbf-in) continuous stall torque; 6000 RPM | β 64ia (64K) | β SVM1-20i ZA06B-6130-H002 | Motor Only: ZA06B-0115-B203 Motor w/ Brake: ZA06B-0115-B503 |
| β 1/6000 <i>is</i> | 1.2 Nm (10.6 lbf-in) continuous stall torque; 6000 RPM | β 64ia (64K) | β SVM1-20i ZA06B-6130-H002 | Motor Only: ZA06B-0116-B203 Motor w/ Brake: ZA06B-0116-B503 |
| β 2/4000 <i>is</i> | 2 Nm (17.7 lbf-in) continuous stall torque; 4000 RPM | β 128ia (128K) | β SVM1-20i ZA06B-6130-H002 | Motor Only: ZA06B-0061-B203 Motor w/ Brake: ZA06B-0061-B503 |
| β 4/4000 <i>is</i> | 3.5 Nm (31.0 lbf-in) continuous stall torque; 4000 RPM | β 128ia (128K) | β SVM1-20i * ZA06B-6130-H002 | Motor Only: ZA06B-0063-B203 Motor w/ Brake: ZA06B-0063-B503 |
| β 8/3000 <i>is</i> | 7 Nm (62.0 lbf-in) continuous stall torque; 3000 RPM | β 128ia (128K) | β SVM1-20i ** ZA06B-6130-H002 | Motor Only: ZA06B-0075-B203 Motor w/ Brake: ZA06B-0075-B503 |
| β 12/3000 <i>is</i> | 11 Nm (97.4 lbf-in) continuous stall torque; 3000 RPM | β 128ia (128K) | β SVM1-40i ZA06B-6130-H003 | Motor Only: ZA06B-0078-B203 Motor w/ Brake: ZA06B-0078-B503 |
| β 22/2000 <i>is</i> | 20 Nm (177.0 lbf-in) continuous stall torque; 2000 RPM | β 128ia (128K) | β SVM1-40i ZA06B-6130-H003 | Motor Only: ZA06B-0085-B203 Motor w/ Brake: ZA06B-0085-B503 |

* Requires Fan Kit (ZA06B-6134-K003) for single-phase mains power.

** Fan Kit (ZA06B-6134-K003) always required.

Servo Products Specification Guide

Table III-2. β HVi Series Servo Systems (460 VAC Main Power)

| <i>Motor</i> | <i>Rated Torque</i> | <i>Encoder</i> | <i>Required Amplifier</i> | <i>Motor Catalog #</i> |
|--------------------|--|-------------------------|---------------------------------------|--|
| β 2/4000HVi | 2 Nm (17.7 lbf-in) continuous stall torque; 5000 RPM | β 128ia (128K) | β SVM1-10HVi ZA06B-6131-H001 | Motor Only: ZA06B-0062-B203 Motor w/ Brake: ZA06B-0062-B503 |
| β 4/4000HVi | 3.5 Nm (31 lbf-in) continuous stall torque; 5000 RPM | β 128ia (128K) | β SVM1-10HVi ZA06B-6131-H001 | Motor Only: ZA06B-0064-B203 Motor w/ Brake: ZA06B-0064-B503 |
| β 8/3000HVi | 7 Nm (62 lbf-in) continuous stall torque; 3000 RPM | β 128ia (128K) | β SVM1-10HVi ZA06B-6131-H001 | Motor Only: ZA06B-0076-B203 Motor w/ Brake: ZA06B-0076-B503 |
| β 12/3000HVi | 11 Nm (97.4 lbf-in) continuous stall torque; 3000 RPM | β 128ia (128K) | β SVM1-20HVi ZA06B-6131-H002 | Motor Only: ZA06B-0079-B203 Motor w/ Brake: ZA06B-0079-B503 |
| β 22/2000HVi | 20 Nm (177.0 lbf-in) continuous stall torque; 2000 RPM | β 128ia (128K) | β SVM1-20HVi ZA06B-6131-H002 | Motor Only: ZA06B-0086-B203 Motor w/ Brake: ZA06B-0086-B503 |

16.2 β i Series Servo Amplifier Packages

The following table shows which amplifier model is included in each β i Series servo package:

Table III-3. β i and β HVi Series Servo Amplifiers and Packages

| Motor | Amplifier Model | Amplifier Catalog # | Amplifier Package Catalog # |
|---------------------|------------------------|----------------------------|------------------------------------|
| β 0.4/5000is | β SVM1-20i | ZA06B-6130-H002 | IC800BIK020 |
| β 0.5/6000is | β SVM1-20i | ZA06B-6130-H002 | IC800BIK020 |
| β 1/6000is | β SVM1-20i | ZA06B-6130-H002 | IC800BIK020 |
| β 2/4000is | β SVM1-20i | ZA06B-6130-H002 | IC800BIK020 |
| β 4/4000is | β SVM1-20i | ZA06B-6130-H002 | IC800BIK020 |
| β 8/3000is | β SVM1-20i | ZA06B-6130-H002 | IC800BIK020 |
| β 12/3000is | β SVM1-40i | ZA06B-6130-H003 | IC800BIK040 |
| β 22/2000is | β SVM1-40i | ZA06B-6130-H003 | IC800BIK040 |
| β 2/4000HVis | β SVM1-10HVi | ZA06B-6131-H001 | IC800BIHV010 |
| β 4/4000HVis | β SVM1-10HVi | ZA06B-6131-H001 | IC800BIHV010 |
| β 8/3000HVis | β SVM1-10HVi | ZA06B-6131-H001 | IC800BIHV010 |
| β 12/3000HVis | β SVM1-20HVi | ZA06B-6131-H002 | IC800BIHV020 |
| β 22/2000HVis | β SVM1-20HVi | ZA06B-6131-H002 | IC800BIHV020 |

As a convenience, amplifiers can also be ordered as a package containing all of the components required to operate the amplifier in a servo system, as detailed in the following table:

Table III-4. β i Series Servo Amplifier Packages

| Description | Package Contents* | Catalog # |
|---|---|------------------|
| 20 Amp β i-Series Amplifier Package | <ul style="list-style-type: none"> ■ βSVM1-20i 20A amplifier (ZA06B-6130-H002) – Qty 1 ■ Spare 24 VDC Fuse (ZA06B-6073-K250) – Qty 1 ■ 20 Watt Discharge Resistor (ZA06B-6130-H401) – Qty 1 ■ CZ7 Power Connector Kit (ZA06B-6130-K200) – Qty1 ■ CXA19 24 VDC Connector Kit (ZA06B-6130-K201) – Qty 2 ■ CXA20 Discharge Thermostat Connector Kit (ZA06B-6130-K202) – Qty 1 ■ CX29 MCC Connector Kit (ZA06B-6130-K203) – Qty 1 ■ CX30 E-stop Connector Kit (ZA06B-6130-K204) – Qty 1 | IC800BIK020 |
| 40 Amp β i-Series Amplifier Package | <ul style="list-style-type: none"> ■ βSVM1-40i 40A amplifier (ZA06B-6130-H003) – Qty 1 ■ Spare 24 VDC Fuse (ZA06B-6073-K250) – Qty 1 ■ 20 Watt Discharge Resistor (ZA06B-6130-H401) – Qty 1 ■ CZ4 Power Connector Kit (ZA06B-6110-K200#XXS) – Qty1 ■ CZ5 Motor Power Connector Kit (ZA06B-6110-K202#YYs) – Qty 1 ■ CZ6 Discharge Resistor Connector Kit (ZA06B-6110-K201#XYM) – Qty 1 ■ CXA19 24 VDC Connector Kit (ZA06B-6130-K201) – Qty 2 ■ CXA20 Discharge Thermostat Connector Kit (ZA06B-6130-K202) – Qty 1 ■ CX29 MCC Connector Kit (ZA06B-6130-K203) – Qty 1 ■ CX30 E-stop Connector Kit (ZA06B-6130-K204) – Qty 1 | IC800BIK040 |

Servo Products Specification Guide

| <i>Description</i> | <i>Package Contents*</i> | <i>Catalog #</i> |
|--|---|------------------|
| 10 Amp β HVi Series (High Voltage) Amplifier Package | <ul style="list-style-type: none"> ■ SVM1-10HVi Amplifier (ZZA06B-6131-H001) – Qty 1 ■ Spare 24 VDC Fuse (ZA06B-6073-K250) – Qty 1 ■ CZ4 Power Connector Kit (ZA06B-6110-K200#XXS) – Qty 1 ■ CZ5 Motor Power Connector Kit (ZA06B-6110-K202#YYS) – Qty 1 ■ CZ6 Regenerative Discharge Resistor Connector Kit (ZA06B-6110-K201#XYM) – Qty 1 ■ CXA19 24 VDC Connector Kit (ZA06B-6130-K201) – Qty 2 ■ CXA20 Regenerative Resistor Thermostat Connector Kit (ZA06B-6130-K202) – Qty 1 ■ CX29 MCC Connector Kit (ZA06B-6130-K203) – Qty 1 ■ CX30 Estop Connector Kit (ZA06B-6130-K204) – Qty 1 | IC800BIHV010 |
| 20 Amp β HVi Series (High Voltage) Amplifier Package | <ul style="list-style-type: none"> ■ SVM1-20HVi Amplifier (ZA06B-6131-H002) – Qty 1 ■ Spare 24 VDC Fuse (ZA06B-6073-K250) – Qty 1 ■ CZ4 Power Connector Kit (ZA06B-6110-K200#XXS) – Qty 1 ■ CZ5 Motor Power Connector Kit (ZA06B-6110-K202#YYS) – Qty 1 ■ CZ6 Regenerative Discharge Resistor Connector Kit (ZA06B-6110-K201#XYM) – Qty 1 ■ CXA19 24 VDC Connector Kit (ZA06B-6130-K201) – Qty 2 ■ CXA20 Regenerative Resistor Thermostat Connector Kit (ZA06B-6130-K202) – Qty 1 ■ CX29 MCC Connector Kit (ZA06B-6130-K203) – Qty 1 ■ CX30 Estop Connector Kit (ZA06B-6130-K204) – Qty 1 | IC800BIHV020 |

* Amplifier package components can also be ordered separately.

Section 17: β i Servo System Options

Designing a servo control system requires that you understand how the electrical and mechanical aspects of your system interact. The table below will help you select which servo options your system requires.

Table III-5. β i Servo System Options

| Servo Option | Consider Selecting When | Catalog # | Section # |
|---|--|--|------------------|
| Motor Holding Brake | The system design includes an axis that must hold its position when power is removed | Refer to Table 5HIII-1 | 18.4 |
| Absolute Encoder Battery Backup Kit | You want to avoid having to re-reference the position when power is restored to the control | IC800BBK021 (1-axis) IC800ABK001 (4-axis) | 19.5 |
| AC Line Filters | 200—240 VAC is already available to the control cabinet and no isolation transformer is used | 5.4 kW, 3-phase: ZA81L-0001-0083#3C 10.5 kW, 3-phase: ZA81L-0001-0101#C | 23.2 |
| Pre-finished Cables | The cable lengths available from GE Fanuc are appropriate for your application | Refer to “Cable Connections” Table | 24 |
| Discharge Resistor | See “Discharging Regenerative Energy;” The 20 Watt discharge resistor is included in all 20 amp β i Series Amplifier Packages. The 40 amp amplifier includes an integral discharge resistor. The external 100 W discharge resistor offers additional capacity when required. | ZA06B-6130-H401 ZA06B-6130-H402 ZA06B-6089-H500 ZA06B-6089-H713 | 23.7 |
| Ground Clamp | CE Installation or high electrical noise environment. | ZA99L-0035-0001, Clamp Z44B295864-001, Bar | 22.3 |
| Absolute Encoder Battery Backup Connector | You want to daisy chain multiple amplifiers together to share the multi-axis battery pack IC800ABK001. | ZA06B-6093-K303 | NA |

Table III-6. β HVi Servo System Options

| Servo Option | Consider Selecting When | Catalog # | Section # |
|---|--|---|------------------|
| Motor Holding Brake | The system design includes an axis that must hold its position when power is removed | Refer to Table 5HIII-1 | 18.4 |
| Absolute Encoder Battery Backup Kit | You would like to avoid having to re-reference the position when power is restored to the control | IC800BBK021 (1-axis) IC800ABK001 (4-axis) | 19.5 |
| AC Line Filters | 400—480 VAC is already available to the control cabinet and no isolation transformer is used | 5.4 kW, 3-phase: ZA81L-0001-0168 10.5 kW, 3-phase: ZA81L-0001-0169 | 23.2 |
| Pre-finished Cables | The cable lengths available from GE Fanuc are appropriate for your application | Refer to “Cable Connections” Table | 24 |
| Ground Clamp | CE Installation or high electrical noise environment. | ZA99L-0035-0001, Clamp Z44B295864-001, Bar | 22.3 |
| Absolute Encoder Battery Backup Connector | You want to daisy chain multiple amplifiers together to share the multi-axis battery pack IC800ABK001. | ZA06B-6093-K303 | NA |

Section 18: Servo Motors

18.1 Servo Motor Specifications

The βi Series Servo system consists of a servomotor and its corresponding amplifier and cables. GE Fanuc offers several βi s series servo motors, which are identified below.

Table III-7. Specifications of βi s Servo Motors

| | Unit | $\beta 0.4/5000is$ | $\beta 0.5/6000is$ | $\beta 1/6000is$ | $\beta 2/4000is$ | $\beta 4/4000is$ | $\beta 8/3000is$ | $\beta 12/3000is$ | $\beta 22/2000is$ |
|-----------------------------|--|--------------------|--------------------|------------------|------------------|------------------|------------------|-------------------|-------------------|
| Rated torque at stall * | Nm | 0.4 | 0.65 | 1.2 | 2.0 | 3.5 | 7.0 | 11.0 | 20.0 |
| | lbf-in | 3.5 | 5.8 | 10.6 | 17.7 | 31.0 | 62.0 | 97.4 | 177.0 |
| Stall Current * | A (rms) | 3.6 | 2.9 | 2.7 | 3.3 | 4.7 | 6.0 | 10.2 | 11.3 |
| Rated Output * | kW | 0.13 | 0.2 | 0.4 | 0.5 | 0.75 | 1.2 | 1.8 | 2.5 |
| | HP | 0.17 | 0.27 | 0.54 | 0.67 | 1.0 | 1.6 | 2.4 | 3.4 |
| Rated Speed | RPM | 4000 | 6000 | 6000 | 4000 | 3000 | 2000 | 2000 | 2000 |
| Max. Speed | RPM | 5000 | 6000 | 6000 | 4000 | 4000 | 3000 | 3000 | 2000 |
| Peak Torque * | Nm | 1.0 | 2.5 | 5.0 | 7.0 | 10.0 | 15.0 | 27.0 | 45.0 |
| | lbf-in | 8.9 | 22.1 | 44.3 | 62.0 | 88.5 | 132.8 | 239.0 | 398.3 |
| Rotor Inertia | Kgm ² | 0.00001 | 0.000018 | 0.000034 | 0.000291 | 0.000515 | 0.00117 | 0.00228 | 0.00527 |
| | lbf-ft-s ² * (10 ⁻⁶) | 7.3756215 | 13.276118 | 25.07711 | 214.6305 | 379.8445 | 862.9477 | 1681.6417 | 3886.9525 |
| Rotor Inertia (with brake) | Kgm ² | 0.000019 | 0.000027 | 0.000043 | 0.000311 | 0.000535 | 0.00124 | 0.00235 | 0.00587 |
| | lbf-ft-s ² * (10 ⁻⁶) | 14.013681 | 19.914178 | 31.715172 | 229.38182 9 | 394.59575 0 | 914.5771 | 1733.27105 | 4329.48982 |
| Torque Constant * | Nm/A | 0.112 | 0.223 | 0.45 | 0.62 | 0.75 | 1.16 | 1.08 | 1.77 |
| | Lbf-in/A | | | | | | | | |
| Back EMF Const. (1 phase) * | Vsec/rad (rms) | 0.038 | 0.074 | 0.14 | 0.21 | 0.25 | 0.39 | 0.36 | 0.59 |
| Resistance (1 phase) * | ohm | 0.55 | 0.85 | 1.5 | 1.6 | 0.94 | 1.00 | 0.39 | 0.44 |
| Mechanical Time Constant | sec | 0.001 | 0.0009 | 0.0007 | 0.004 | 0.003 | 0.003 | 0.002 | 0.002 |
| Thermal time Constant | min | 8 | 10 | 15 | 15 | 20 | 20 | 25 | 30 |
| Static friction | Nm | 0.04 | 0.04 | 0.04 | 0.1 | 0.2 | 0.3 | 0.4 | 0.8 |
| Weight | kg | 0.8 | 1.0 | 1.5 | 2.8 | 4.3 | 7.4 | 11.9 | 17.0 |
| | lb | 1.8 | 2.2 | 3.3 | 6.2 | 9.5 | 16.3 | 26.2 | 37.4 |
| Weight (with brake) | kg | 1.2 | 1.4 | 1.9 | 3.8 | 5.3 | 9.6 | 14.1 | 23.0 |
| | lb | 2.6 | 3.1 | 4.2 | 8.4 | 11.7 | 21.1 | 31.0 | 50.6 |
| Max Current | A (peak) | 20 | 20 | 20 | 20 | 20 | 20 | 40 | 40 |

*These values are standard values at 20°C with a tolerance of $\pm 10\%$. The speed-torque characteristics vary, depending on the type of software, parameter setting, and input voltage of the digital servo amplifiers. (The above figures show average values.) These values may be changed without prior notice.

Servo Products Specification Guide

Table III-8. Specifications of β HVIs Servo Motors

| | Unit | β 2/4000HVIs | β 4/4000HVIs | β 8/3000HVIs | β 12/3000HVIs | β 22/2000HVIs |
|-----------------------------|--|--------------------|--------------------|--------------------|---------------------|---------------------|
| Rated torque at stall * | Nm | 2 | 3.5 | 7 | 11 | 20 |
| | lbf-in | 17.7 | 31 | 62 | 97.4 | 177.02 |
| Stall Current * | A (rms) | 1.6 | 2.3 | 3 | 5.1 | 5.6 |
| Rated Output * | kW | 0.5 | 0.75 | 1.2 | 1.8 | 2.5 |
| | HP | 0.67 | 1 | 1.6 | 2.4 | 3.4 |
| Rated Speed | RPM | 4000 | 3000 | 2000 | 2000 | 2000 |
| No Load Speed | RPM | 4000 | 4000 | 3000 | 3000 | 2000 |
| Encoder Resolution | Counts/Rev | 131,072 | 131,072 | 131,072 | 131,072 | 131,072 |
| Flange Size | mm | 90 | 90 | 130 | 130 | 174 |
| Peak Torque * | Nm | 7 | 10 | 15 | 27 | 45 |
| | lbf-in | 62 | 88.5 | 132.8 | 2.9 | 398.3 |
| Rotor Inertia | Kgm ² | 2.91 | 5.15 | 11.7 | 22.8 | 52.7 |
| | lbf-ft-s ² *(10 ⁻⁶) | 25.76 | 45.58 | 103.55 | 201.80 | 466.43 |
| Rotor Inertia (with brake) | Kgm ² | 3.11 | 5.35 | 12.4 | 23.5 | 58.7 |
| | lbf-ft-s ² *(10 ⁻⁶) | 25.73 | 47.35 | 109.75 | 208.0 | 519.4 |
| Torque Constant * | Nm/A | 1.23 | 1.5 | 2.32 | 2.16 | 3.5 |
| | Lbf-in/A | 10.89 | 13.28 | 20.53 | 19.12 | 30.98 |
| Back EMF Const. (1 phase) * | Vsec/rad (rms) | 43 | 53 | 81 | 76 | 120 |
| Resistance (1 phase) * | ohm | 6.6 | 4 | 3.9 | 1.6 | 1.8 |
| Mechanical Time Constant | sec | 4 | 3 | 3 | 2 | 2 |
| Thermal time Constant | min | 15 | 20 | 20 | 25 | 30 |
| Static friction | Nm | 0.1 | 0.2 | 0.3 | 0.4 | 0.8 |
| Weight | kg | 2.8 | 4.3 | 7.4 | 11.9 | 17 |
| | lb | 6.16 | 9.46 | 16.28 | 26.18 | 37.4 |
| Weight (with brake) | kg | 3.8 | 5.3 | 9.6 | 14.1 | 23.0 |
| | lb | 8.4 | 11.7 | 21.1 | 31.0 | 50.6 |
| Axial Load Rating | kg | 8 | 8 | 20 | 20 | 60 |
| | lb | 17.6 | 17.6 | 44 | 44 | 132 |
| Radial Load Rating | kg | 25 | 25 | 70 | 70 | 200 |
| | lb | 55 | 55 | 154 | 154 | 440 |
| Max Current | A (peak) | 10 | 10 | 10 | 20 | 20 |

*These values are standard values at 20°C with a tolerance of $\pm 10\%$. The speed-torque characteristics vary, depending on the type of software, parameter setting, and input voltage of the digital servo amplifiers. (The above figures show average values.) These values may be changed without prior notice.

18.2 β is and β HVi Series Motor Speed–Torque Curves

The curves shown in the following figure illustrate the relationship between the speed of the motor and the output torque. The motor can operate continuously at any combination of speed and torque within the prescribed continuous operating zone. The limit of the continuous operating zone is determined with the motor’s ambient temperature at 20°C and its drive current as pure sine wave. The curves reflect peak torque limits based on maximum current of the servo amplifier unit.

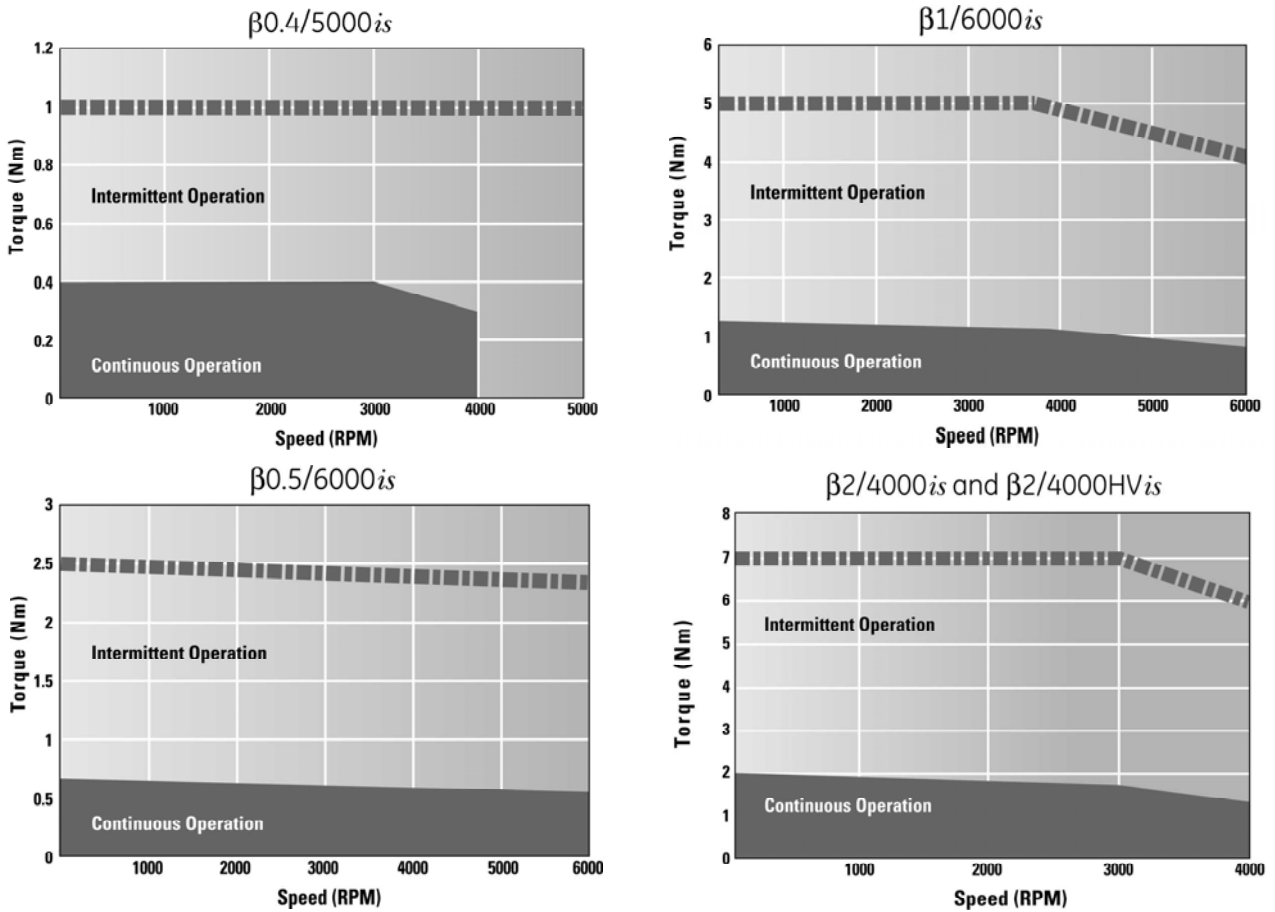

Figure III-1. β is and β HVi Series Servo Motor Speed-Torque Curves ($\beta 0.4/6000$, $\beta 0.5/6000$, $\beta 1/6000$, $\beta 2/4000$)

Servo Products Specification Guide

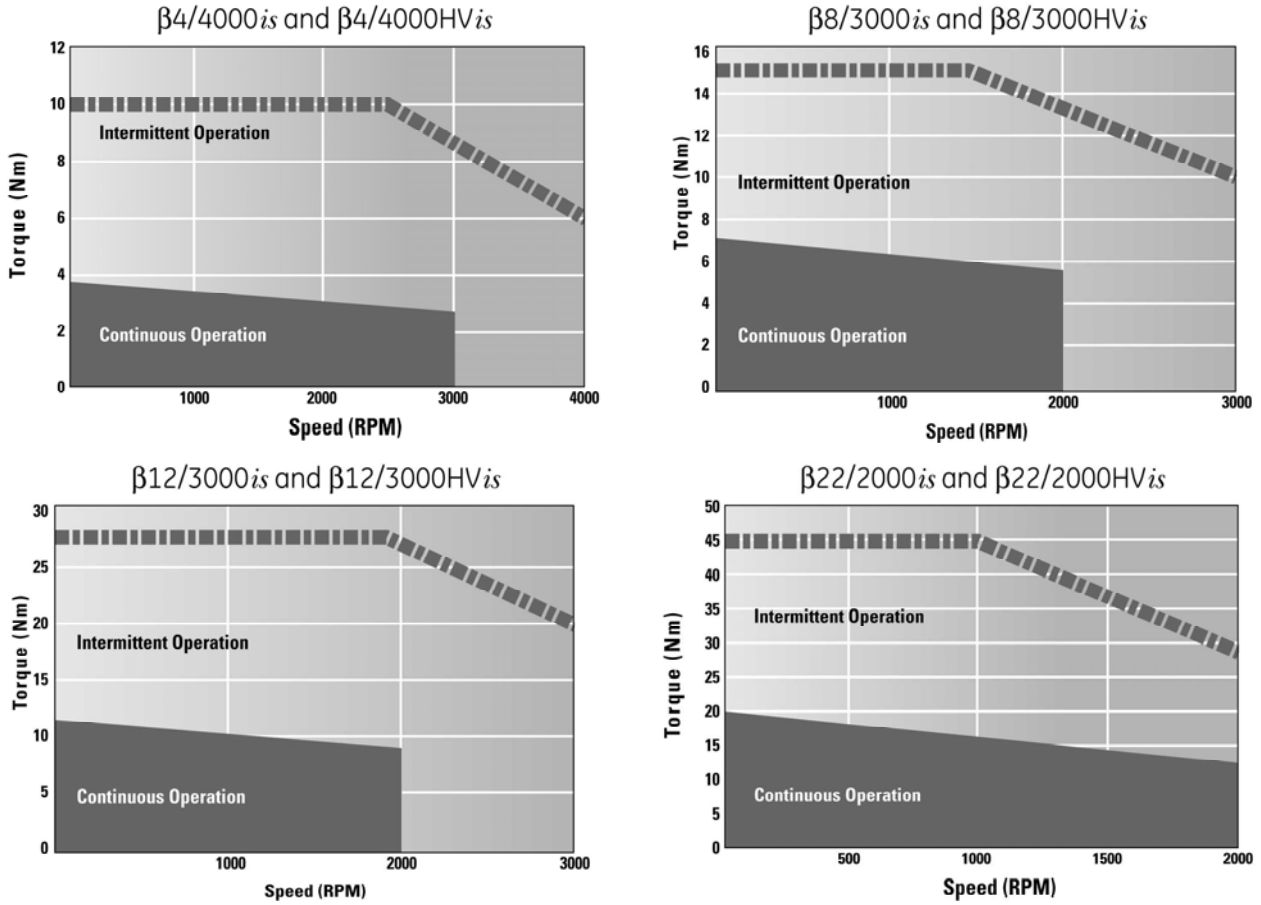
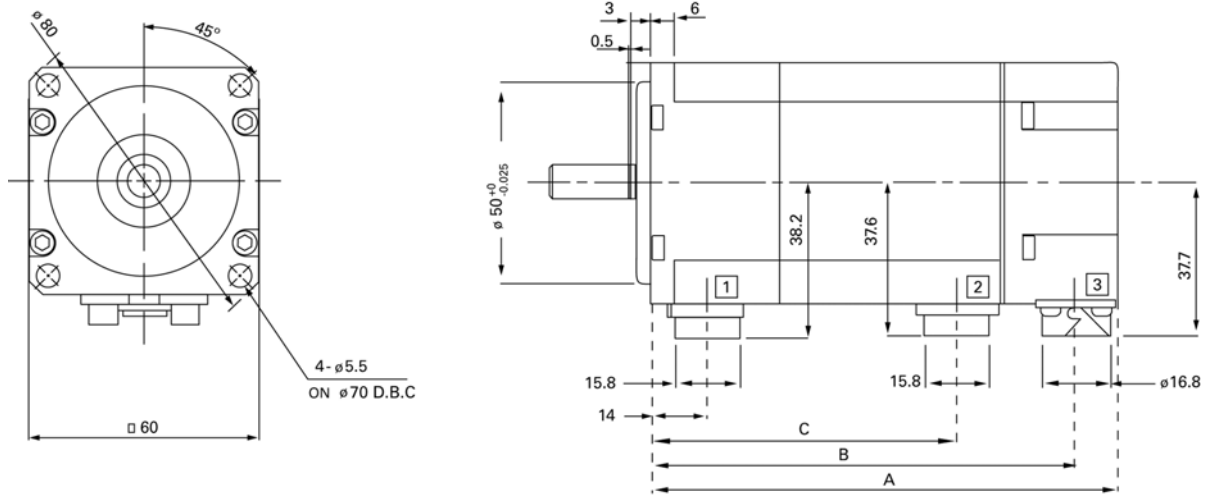
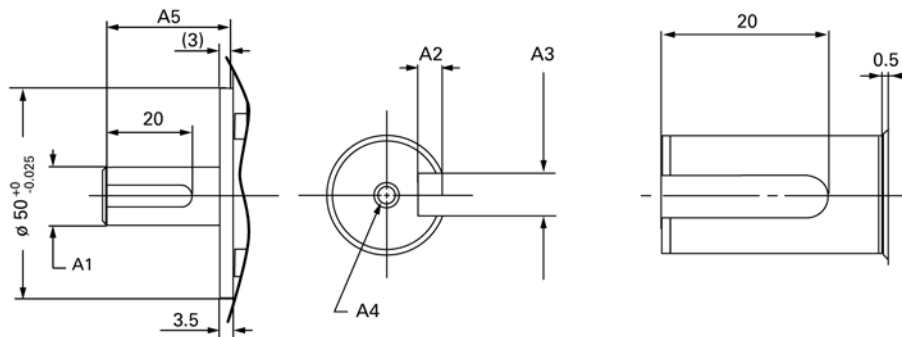

Figure III-2. βis and $\beta HVis$ Series Servo Motor Speed-Torque Curves ($\beta 4/4000$, $\beta 8/3000$, $\beta 12/3000$, $\beta 22/2000$)

18.3 Motor Outline Drawings



Motor



Shaft Detail

Dimensions shown mm

| Dimension | $\beta 0.4/5000is$ | $\beta 0.5/6000is$ | $\beta 1/6000is$ |
|--------------|----------------------------|----------------------------|-----------------------------|
| A | 75 | 89.5 | 118.5 |
| A with brake | 101.5 | 116 | 145 |
| A1 | $\phi 9^{+0.000}_{-0.009}$ | $\phi 9^{+0.000}_{-0.009}$ | $\phi 14^{+0.000}_{-0.011}$ |
| A2 | $1.2^{+0.0}_{-0.1}$ | $1.2^{+0.0}_{-0.1}$ | $2^{+0.0}_{-0.1}$ |
| A3 | $3^{+0.000}_{-0.025}$ | $3^{+0.000}_{-0.025}$ | $5^{+0.00}_{-0.33}$ |
| A4 | M3 Depth 6 | M3 Depth 6 | M4 Depth 10 |
| A5 | 25 | 25 | 30 |
| B | 65 | 79.5 | 108.5 |
| B with brake | 91.5 | 106 | 135 |
| C | 34.5 | 49 | 78 |
| C with brake | 61 | 75.5 | 104.5 |

| Connector | Description |
|-----------|------------------|
| 1 | Brake (optional) |
| 2 | Power |
| 3 | Encoder |

Notes:

1. Shaft diameter runout = 0.02mm max
2. Flange surface runout = 0.06mm max
3. Maximum radial load for output shaft is 20kgf (44lb)

Figure III-3. $\beta 0.4is$, $\beta 0.5is$ and $\beta 1is$ Series Servo Motor Outline Drawing

Servo Products Specification Guide

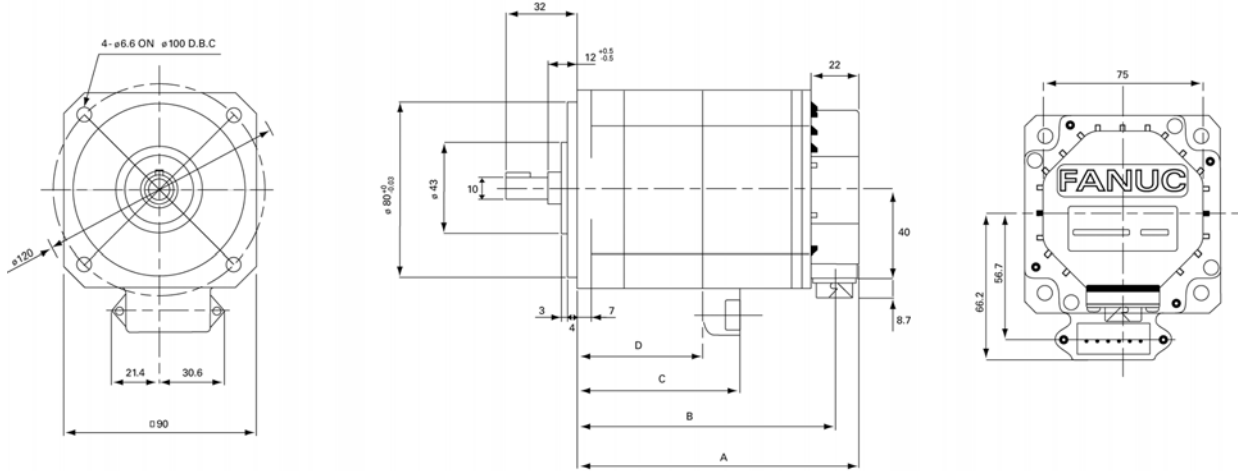

| Power/Brake Connections | | | | | |
|-------------------------|---|---|---|---|---|
| 1 | 2 | 3 | 4 | 5 | 6 |
| U | V | W | G | B | B |

Motor

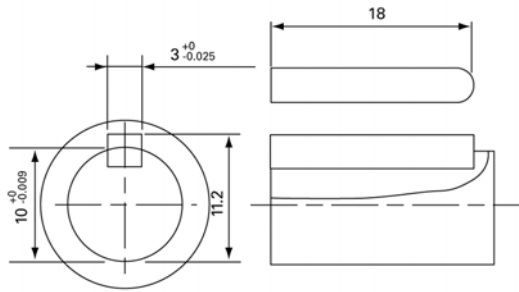

Shaft Detail

Dimensions shown mm

| Dimension | $\beta 2/4000is$, $\beta 2/4000HVis$ |
|--------------|---------------------------------------|
| A | 130 |
| A with brake | 159 |
| B | 119 |
| B with brake | 148 |
| C | 75 |
| C with brake | 75 |
| D | 59 |
| D with brake | 59 |

- Notes:**
1. Shaft diameter runout = 0.02mm max
 2. Flange surface runout = 0.06mm max
 3. Maximum radial load for output shaft is 25kgf (55lb)

Figure III-4. $\beta 2is$ Series Servo Motor Outline Drawing

Servo Products Specification Guide

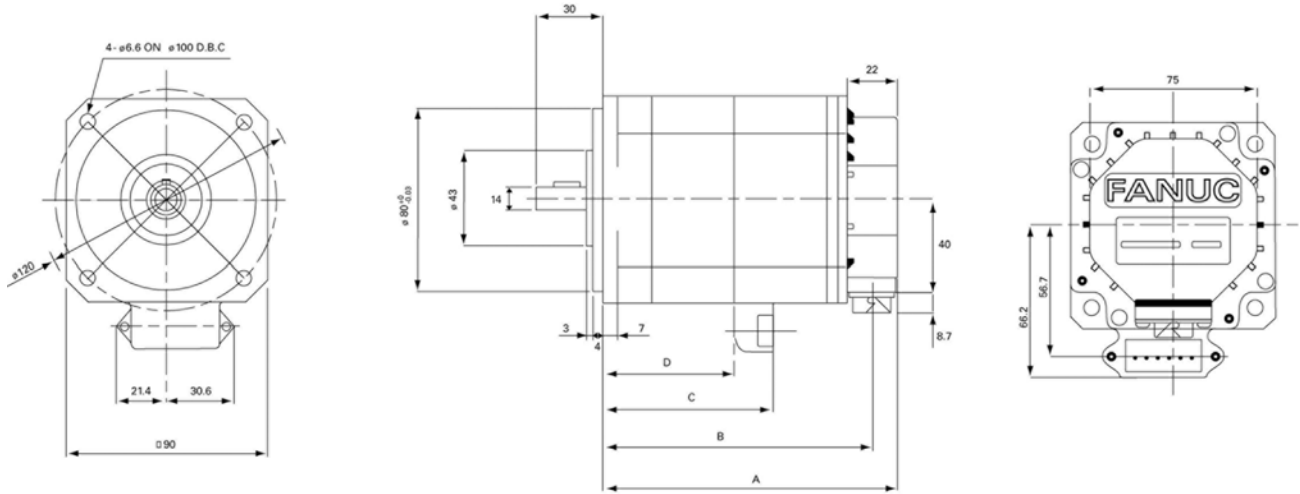

| Power/Brake Connections | | | | | |
|-------------------------|---|---|---|---|---|
| 1 | 2 | 3 | 4 | 5 | 6 |
| U | V | W | G | B | B |

Motor

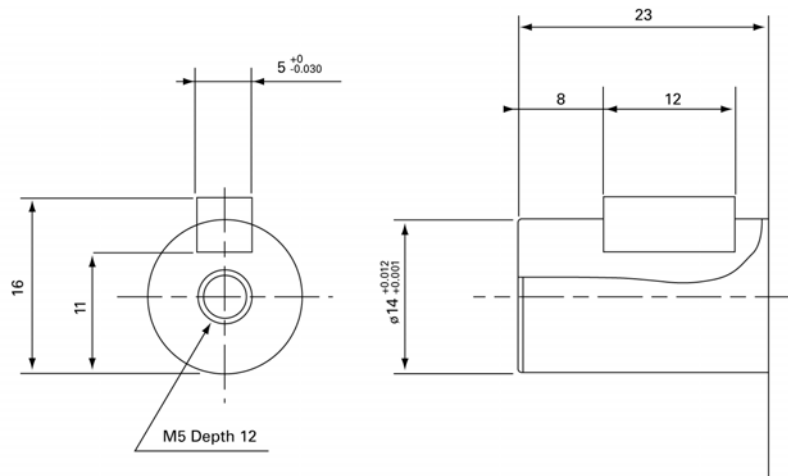

Shaft Detail

Dimensions shown mm

| Dimension | $\beta 4/4000is$, $\beta 4/4000HVis$ |
|--------------|---------------------------------------|
| A | 166 |
| A with brake | 195 |
| B | 155 |
| B with brake | 184 |

| Dimension | $\beta 4/4000is$, $\beta 4/4000HVis$ |
|--------------|---------------------------------------|
| C | 111 |
| C with brake | 111 |
| D | 95 |
| D with brake | 95 |

- Notes:**
1. Shaft diameter runout = 0.02mm max
 2. Flange surface runout = 0.06mm max
 3. Maximum radial load for output shaft is 25kgf (55lb)

Figure III-5. $\beta 4is$ Series Servo Motor Outline Drawing

Servo Products Specification Guide

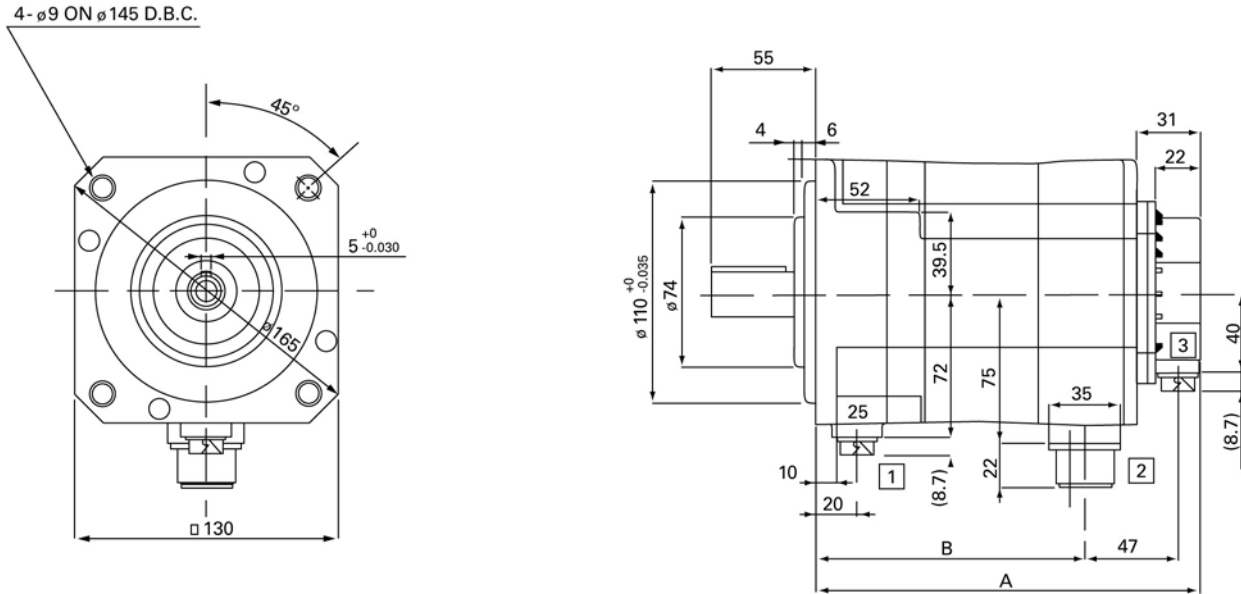

Motor

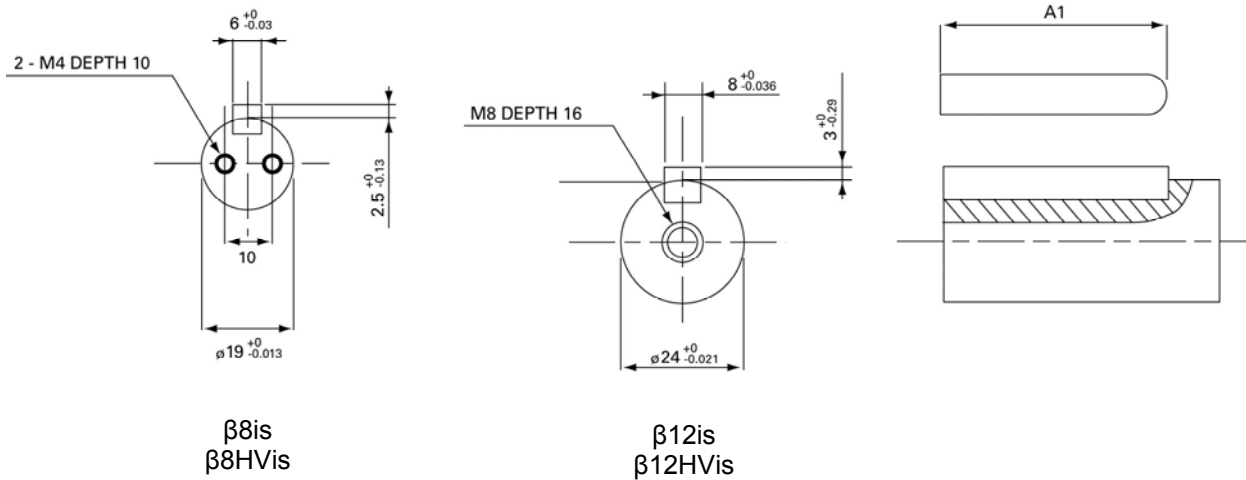

Shaft Detail

Dimensions shown mm

| Dimension | $\beta 8/3000is$, $\beta 8/3000HVis$ | $\beta 12/3000is$, $\beta 12/3000HVis$ |
|--------------|--|--|
| A | 166 | 222 |
| A with brake | 191 | 247 |
| A1 | 36 | 45 |
| B | 108 | 164 |
| B with brake | 133 | 189 |

| Connector | Description |
|-----------|------------------|
| 1 | Brake (optional) |
| 2 | Power |
| 3 | Encoder |

Notes:

1. Shaft diameter runout = 0.02mm max
2. Flange surface runout = 0.05mm max
3. Maximum radial load for output shaft is 70kgf (154lb)

Figure III-6. $\beta 8is$ and $\beta 12is$ Series Servo Motor Outline Drawing

Servo Products Specification Guide

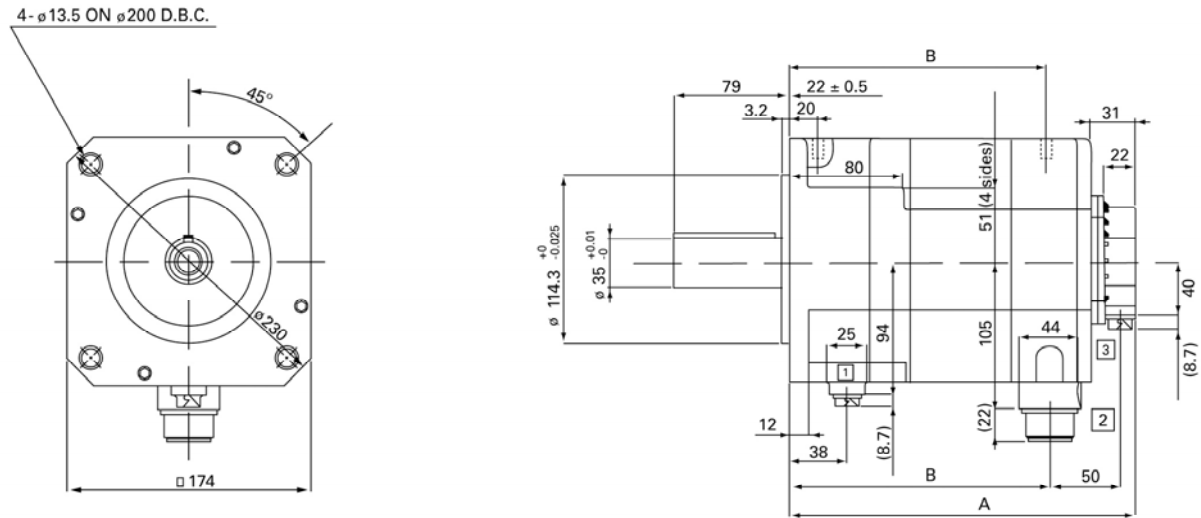

Motor

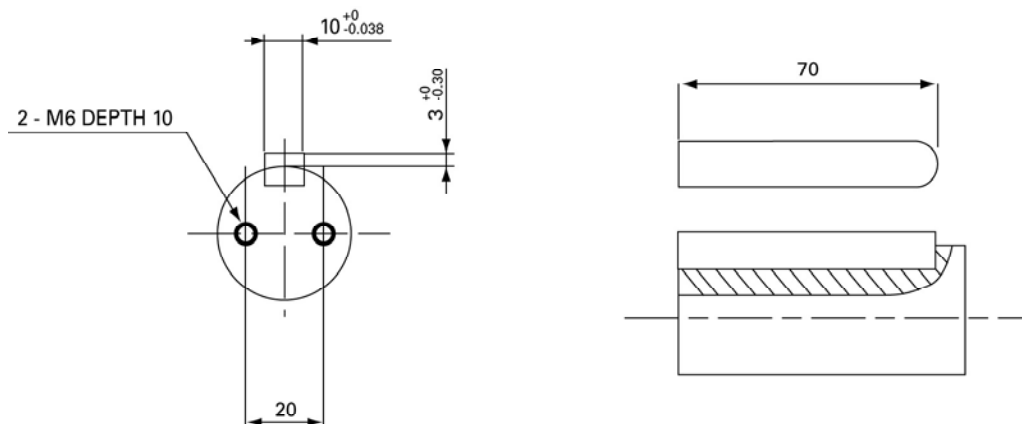

Shaft Detail

Dimensions shown mm

| Dimension | $\beta 22/2000is$, $\beta 22/2000HVis$, |
|--------------|--|
| A | 202 |
| A with brake | 243 |
| B | 141 |
| B with brake | 182 |

| Connector | Description |
|-----------|------------------|
| 1 | Brake (optional) |
| 2 | Power |
| 3 | Encoder |

Notes:

1. Shaft diameter runout = 0.03mm max
2. Flange surface runout = 0.06mm max
3. Maximum radial load for output shaft is 200kgf (440lb)

Figure III-7. $\beta 22is$ Series Servo Motor Outline Drawing

18.4 β is and β HVis Series Servo Motor Holding Brake

The holding brake is used to prevent movement on horizontal axes or falling along the vertical axis when the servo motor control is turned off. Brakes are spring-set and electrically released and are designed for holding stationary loads only. Using the holding brake to stop a moving axis may damage the brake or severely reduce its service life.

The specifications of the built-in brakes are listed in the following table.

Table III-9. β is and β HVis Motor Holding Brake Specifications

| <i>Motor Model</i> | | <i>Unit</i> | <i>β0.4is β0.5is</i> | <i>β1is</i> | <i>β2is/β2HVis β4is/β4HVis</i> | <i>β8is/β8HVis β12is/β12HVis</i> | <i>β22is/β22HVis</i> |
|----------------------|---------|-----------------------|--|------------------------------|--|--|--|
| Brake Holding Torque | | Nm | 0.65 | 1.2 | 3 | 8 | 35 |
| | | lbf-in | 5.8 | 10.6 | 26.6 | 70.8 | 309.8 |
| Response Time | Release | msec | 40 | 40 | 60 | 160 | 160 |
| | Brake | msec | 20 | 20 | 10 | 30 | 30 |
| Power Supply | Voltage | VDC | 24 (\pm 10%) | | | | |
| | Current | A | 0.5 | 0.5 | 0.9 | 1.1 | 1.2 |
| | Power | W | 12 | 12 | 22 | 26 | 29 |
| Weight Increase | | kg | 0.4 | 0.4 | 1.0 | 2.2 | 6.0 |
| Inertia Increase | | kg-m ² | 0.000009 | 0.000009 | 0.00002 | 0.00007 | 0.0006 |
| | | lbf-in-s ² | 0.0000797 | 0.0000797 | 0.000177 | 0.0006195 | 0.000531 |

The values shown above are standard values at 20°C.

18.5 Brake Power Supply Circuit

The following table lists the recommended parts and their specifications to be used as components of a user-built brake circuit. Configure a brake circuit by referencing the following brake connection diagram and the recommended parts as shown below.

Table III-10. β is Holding Brake Circuit Components

| Name | Model No. | Name of Manufacturer | Specifications |
|----------------|------------|--|--|
| Rectifier | D3SB60 | Shindengen Electric Mfg. Co., Ltd. | Withstand voltage 400V min. Maximum output current: 2.3 A (with no fins) |
| Switch | N/A | N/A | Rated load capacity (resistance load) 250VAC 10A / 30VDC 10A or more |
| Spark Killer | XEB0471 | Okaya Electric Ind. Co., Ltd. | 47 ohm/0.1 μ F Withstand voltage 400V min |
| Surge Absorber | ERZV10D820 | Matsushita Electric Industrial Co., Ltd. | Varistor voltage 82V Max allowable voltage 50 VAC |

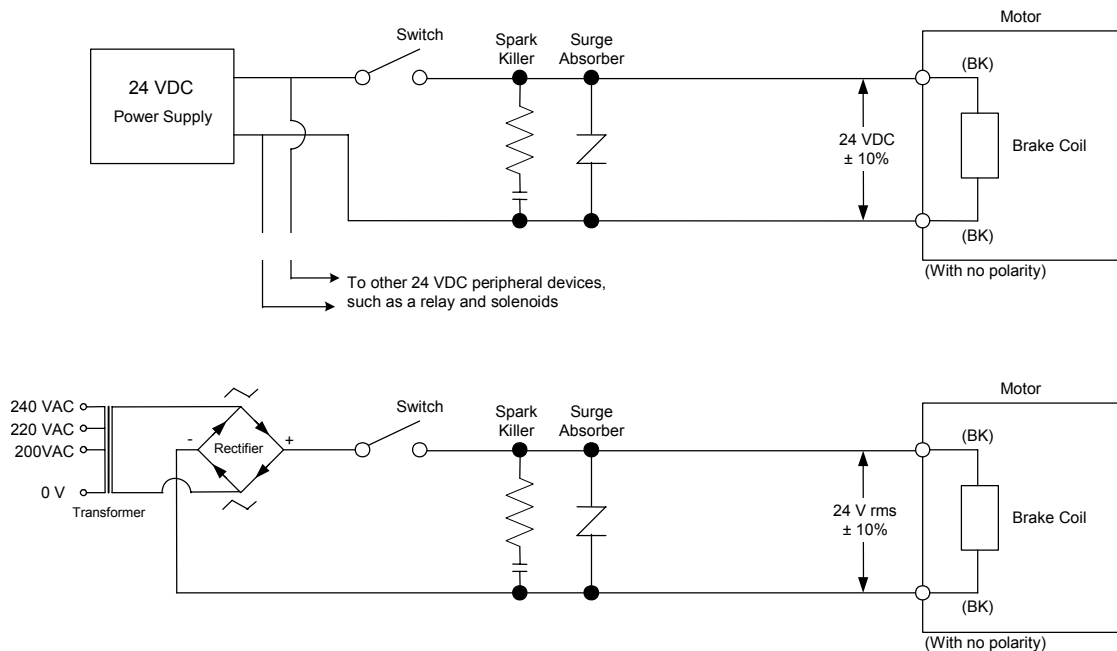

Figure III-8. Connecting Motor Holding Brake Control and Power Circuit

Caution

To prevent amplifier malfunction or damage do not use the same 24V power supply for the amplifier control logic circuitry as the power supply for the brake.

Servo Products Specification Guide

Option 1: Use a commercial 24 VDC power supply as the power supply for the β/s series servo motor brake. To prevent amplifier malfunction or damage do not use the same 24V power supply for the amplifier control logic circuitry as the power supply for the brake. The power supply for a relay, solenoid, or another peripheral device can be used for the brake. Be careful of the power capacity and changes in voltage due to load changes.

Option 2: Alternately you may build a power supply for the brake circuit (equivalent to 24 Vrms) produced by full-wave rectification after transforming commercial power (50 Hz/60 Hz). For user built full-wave rectification, transform the secondary voltage into approximately 29 VAC by taking voltage drop in the rectifier or cable into account. Check to make sure the power capacity and power voltage fluctuations of the voltage applied to the brake falls within 24 Vrms $\pm 10\%$.

If the brake switching contact is installed on the DC side (at the position shown in the figure), the life of the contact is generally shortened due to the surge voltage when the brake is turned off. Provide an adequate contact capacity and always use a surge absorber and spark killer for protecting the contact. Installing the switching contact on the DC side of the power provides the fastest brake operation time.

18.6 Motor Connections

Connections

Serial Encoder Connections

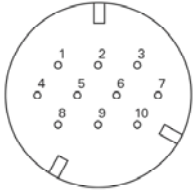

All β is and β HVis Motors

| Description | Motor Connector | Amplifier JF1 Connector |
|--|-----------------|-------------------------|
| N/C | 2 | 1 |
| N/C | 1 | 2 |
| RD | 6 | 5 |
| $\overline{\text{RD}}$ | 5 | 6 |
| +5 VDC | 8,9 | 9,20 |
| 0 VDC | 7,10 | 12,14 |
| +6 VA (battery) | 4 | 7 |
| Frame Ground | 3 | 16 |
| Cable Shield | 3 | 16 |
| GE Fanuc Mating Connector: ZA06B-6114-K204#E (90 degree) ZA06B-6114-K204#S (straight) | | |

Power and Brake Connections

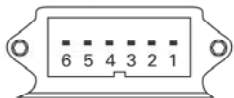

β 2is & β 4is Motor Power/Brake

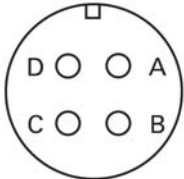

β 8is, β 12is & β 22is Motor Power

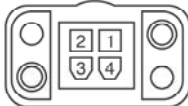

β 0.4is, β 0.5is & β 1is Motor Power



β 8is, β 12is & β 22is Brake

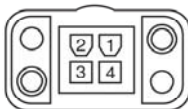

β 0.4is, β 0.5is & β 1is Brake

| Description | β 0.4is, β 0.5is, β 1is Motor Connector | β 2is/ β 2HVis β 4HVis Motor Connector | β 8is/ β 8HVis β 12is/ β 12HVis β 22is/ β 22HVis Motor Connector | β i and β HVi Series Amplifier Connector |
|--|---|--|--|--|
| Phase U | 2 | 1 | A | U |
| Phase V | 2 | 2 | B | V |
| Phase W | 3 | 3 | C | W |
| Earth (case) | 4 | 4 | D | PE |
| Brake VDC | n/a | 5 | n/a | n/a |
| Brake VDC | n/a | 6 | n/a | n/a |
| GE Fanuc Mating Connector: ZA06B-6114-K220#E (90 degree) (β 2is, β 4is, β 2HVis, β 4HVis) ZA06B-6114-K220#S (straight) (β 2is, β 4is, β 2HVis, β 4HVis) Z44A730464-G18 (β 8is, β 12is, β 8HVis, β 12HVis) ZA06B-6114-K230#E (β 0.4is, β 0.5is, β 1is) Z44A730464-G20 (β 22is, β 22HVis) | | | | |

| Description | β 0.4is, β 0.5is & β 1is Motor Connector | β 8is/ β 8HVis β 12is/ β 12HVis β 22is/ β 22HVis Motor Connector |
|---|--|--|
| Brake VDC | 1 | 1 |
| Brake VDC | 2 | 2 |
| Earth (case) | 4 | 4 |
| GE Fanuc Mating Connector: ZA06B-6114-K213#E (90 degree) (β 8is, β 12is, β 22is, β 8HVis, β 12HVis, β 22HVis) ZA06B-6114-K213#S (straight) (β 8is, β 12is, β 22is, β 8HVis, β 12HVis, β 22HVis) ZA06B-6114-K232#E (β 0.4is, β 0.5is, β 1is) | | |

Brake power connections are not polarized 24VDC.

Section 19: β i and β HVi Amplifiers

19.1 Amplifier Electrical Specifications

β i-Series Amplifier Specifications

| Item | SVM1-20i | SVM1-40i |
|-------------------------------------|---|--|
| Power Supply Voltage (amplifier) | 3-Phase 200-240VAC ¹ 1-Phase 200-240VAC ² | 3-Phase 200-240VAC |
| Power Supply Voltage (control) | 24 VDC /0.9A | 24 VDC /0.9A |
| Dynamic Brake Function ³ | Built In | Built In |
| Built In Regeneration Capacity | 16 joule (capacitor energy storage) | 50 watt (internal resistor) |
| External Regeneration Options | 20 watt, 30 ohm – ZA06B-6130-H401 100 watt, 30 ohm - ZA06B-6130-H402 | 200 watt, 16 ohm - ZA06B-6089-H500 800 watt, 16 ohm – ZA06B-6089-H713 |

Notes:

1. 8Nm motor always requires amplifier fan kit ZA06B-6134-K003.
2. 4Nm motor requires amplifier fan kit ZA06B-6134-K003 for single-phase operation only.
3. Dynamic braking activates during servo alarms to stop the motor more quickly than coasting to a stop.

BHVi Series Amplifier Specifications

| Item | SVM1-10HVi | SVM1-20HVi |
|-------------------------------------|-------------------------------------|-----------------------------|
| Power Supply Voltage (amplifier) | 3-Phase 400-480VAC | 3-Phase 400-480VAC |
| Power Supply Voltage (control) | 24 VDC /0.9A | 24 VDC /0.9A |
| Dynamic Brake Function ¹ | Built In | Built In |
| Built In Regeneration Capacity | 16 joule (capacitor energy storage) | 50 watt (internal resistor) |

Note: Dynamic braking activates during servo alarms to stop the motor more quickly than coasting to a stop.

19.2 β i & β VHi Series Amplifier Environmental Specifications

| Item | Specification |
|---------------------|----------------------------------|
| Ambient Temperature | |
| Operation | 0 to 55 °C |
| Storage | -20 to 60 °C |
| Humidity | 90% RH or below (non-condensing) |
| Vibration | Below 0.5 G |

19.3 β i & β HVi Series Amplifier Status LED and Alarm Functions

The Servo Amplifier Unit can detect error conditions and provide alarm information.

The LEDs on the front of the amplifier provide a visual cue to the status of the system by indicating, for example, when the motor and amplifier are ready to function.

- POWER LED (green) indicates the logic 24 VDC power is present.
- DC LINK CHARGED LED (red) indicates that the amplifier has high (motor) voltage DC present.
- LINK LED (green) indicates that the FSSB (fiber optic) interface is functioning.
- ALM LED (yellow) is turned ON when an alarm condition is detected. When an alarm is detected, power is dropped and the motor is stopped by dynamic braking action. Alarm information is additionally displayed as diagnostic data in the GE Fanuc DSM324i motion controller. The amplifier control power must be cycled to reset this alarm state. The table below details the alarm conditions the β i Series Servo Amplifier System can detect.

Servo Products Specification Guide

Table III-11. β i and β HVi Series Servo Amplifier Alarms

| Alarm Condition | Description |
|------------------------------|---|
| DC Link Under-Voltage | Issued when the DC voltage in the main circuit power supply is abnormally low. Indicates low AC mains power dip or hardware problem. Make sure the plug-in (gray faceplate) circuit board is securely seated in the amplifier base. Replace amplifier. |
| DC Link Over-Voltage | Issued when the DC voltage in the main circuit power supply is abnormally high. Indicates high AC mains power or hardware problem. Make sure the plug-in (gray faceplate) circuit board is securely seated in the amplifier base. May also be caused by excessive regenerated power. Increase acceleration/deceleration time and/or add additional regenerative discharge capacity. Replace amplifier. |
| Excessive Deceleration Power | <p>If no external regeneration resistor is used, the discharge resistor thermal sensor jumper is missing on connector CXA20. This input requires a normally closed contact for normal operation.</p> <p>When using an external regeneration resistor, the thermal sensor in the regeneration resistor has tripped. Indicating excessive regenerated power load to the regeneration resistor. Use a meter to confirm an open circuit on the thermal sensor leads. Make sure the plug-in (gray faceplate) circuit board is securely seated in the amplifier base. Increase capacity of external regeneration resistor or decrease deceleration rate or frequency, and/or the top speed from which the axis must decelerate.</p> |
| Control Power Under-Voltage | The 24 VDC control power is below 21.6 VDC. Check the supply voltage level and make sure the CXA19A and CXA19B connectors are secure and associated cables are wired correctly. Replace amplifier. |
| Internal Cooling Fan Stopped | Fan is jammed, has failed or is not connected. Check for foreign material in fan blades. Make sure fan is plugged in. Make sure the plug-in (gray faceplate) circuit board is securely seated in the amplifier base. Replace amplifier. |
| IPM Alarm | Excessive current in the power transistors. Phase to phase or phase to ground short circuit on motor power output. Make sure the plug-in (gray faceplate) circuit board is securely seated in the amplifier base. Possible incorrect phase connection of the motor power wiring. Motor type code must be configured correctly in the GE Fanuc controller. Disconnect motor power leads from amplifier and reset E-stop condition. If IPM alarm occurs replace amplifier. If no IPM alarm the problem is in the motor or motor power cable. Check for electrical shorts in the motor power cable or motor winding shorted to frame ground. |
| IPM Overheat | Issued when the temperature inside the amplifier becomes so high that the thermostat trips. Make sure the plug-in (gray faceplate) circuit board is securely seated in the amplifier base. Check that the heat sink cooling fan (if applicable) is running. Make sure the ambient temperature around the amplifier is 55°C or lower. Check that the motor load is within the rating of the motor. |
| Motor Over-current | Issued when an abnormally high current is detected in the main circuit. Make sure the plug-in (gray faceplate) circuit board is securely seated in the amplifier base. Check for electrical shorts in the motor power cable or motor winding shorted to frame ground. Possible incorrect phasing on motor power wiring. Motor type code may be configured incorrectly in the DSM324 controller. Possible excessive force loading on motor. |
| FSSB Communication Error | FSSB connector or cable failure. Check the connections to the COP10A and COP10B connectors. Try replacing the optical cable. Replace amplifier. |

19.4 Amplifier External Dimensions

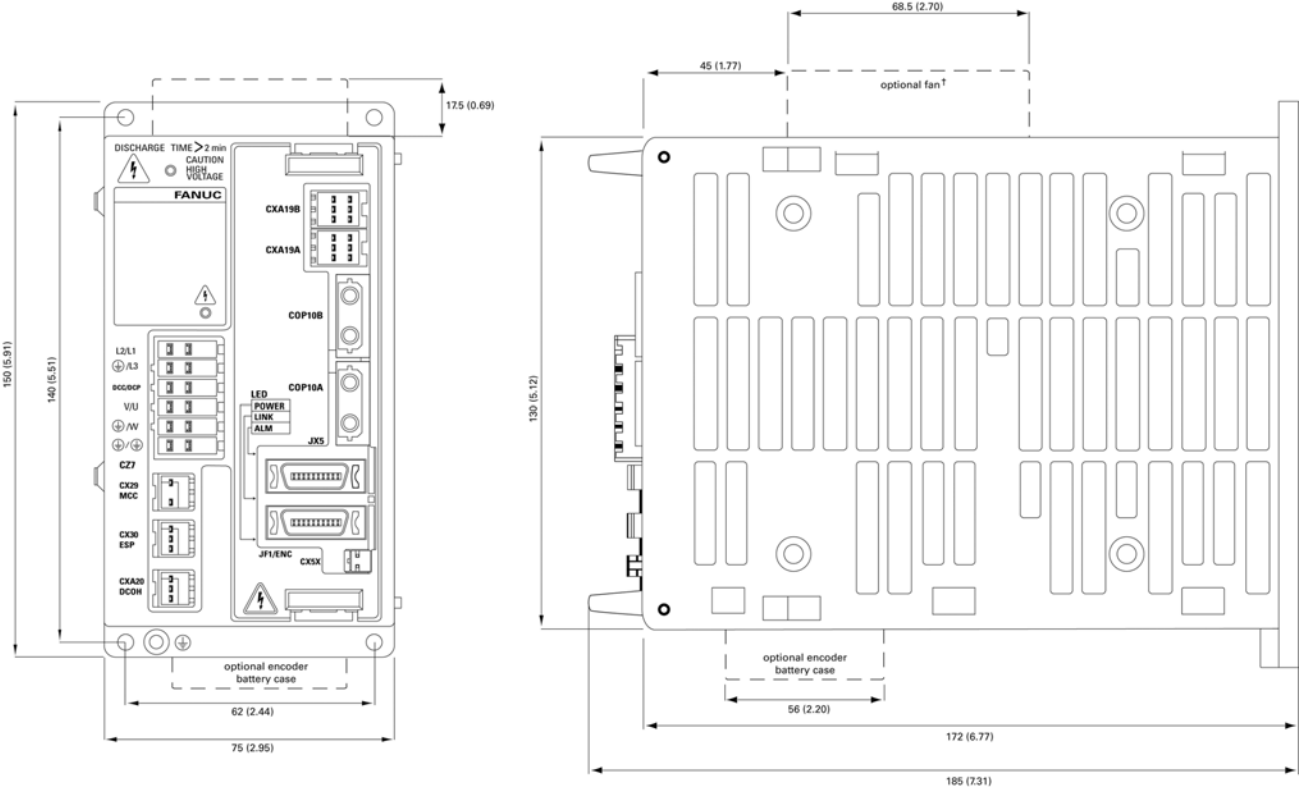

Figure III-9. External Dimensions of betaSVM1-20i Amplifier

Servo Products Specification Guide

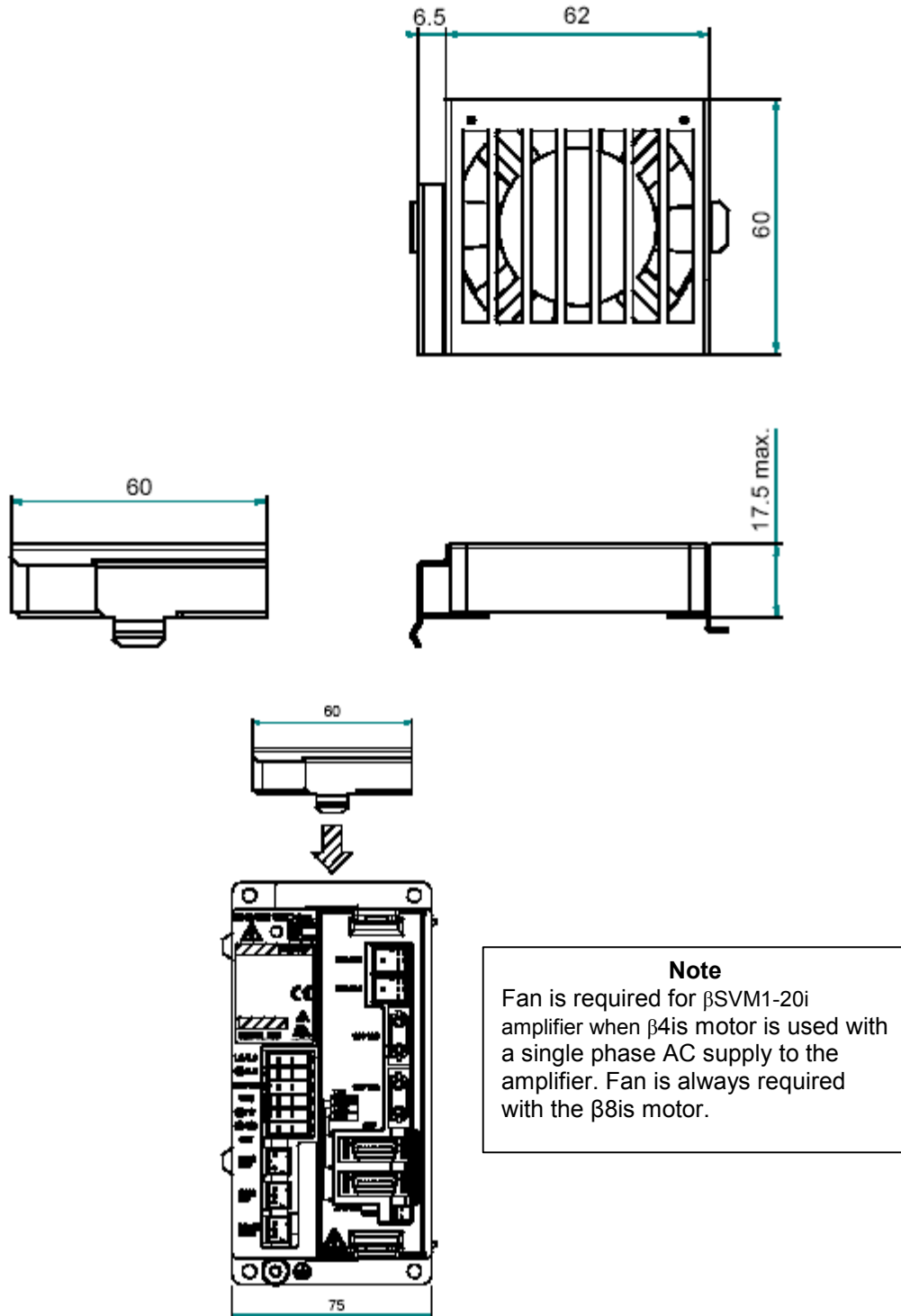

Figure III-10. External Dimensions of Optional Cooling Fan Unit (ZA06B-6134-K003)

Servo Products Specification Guide

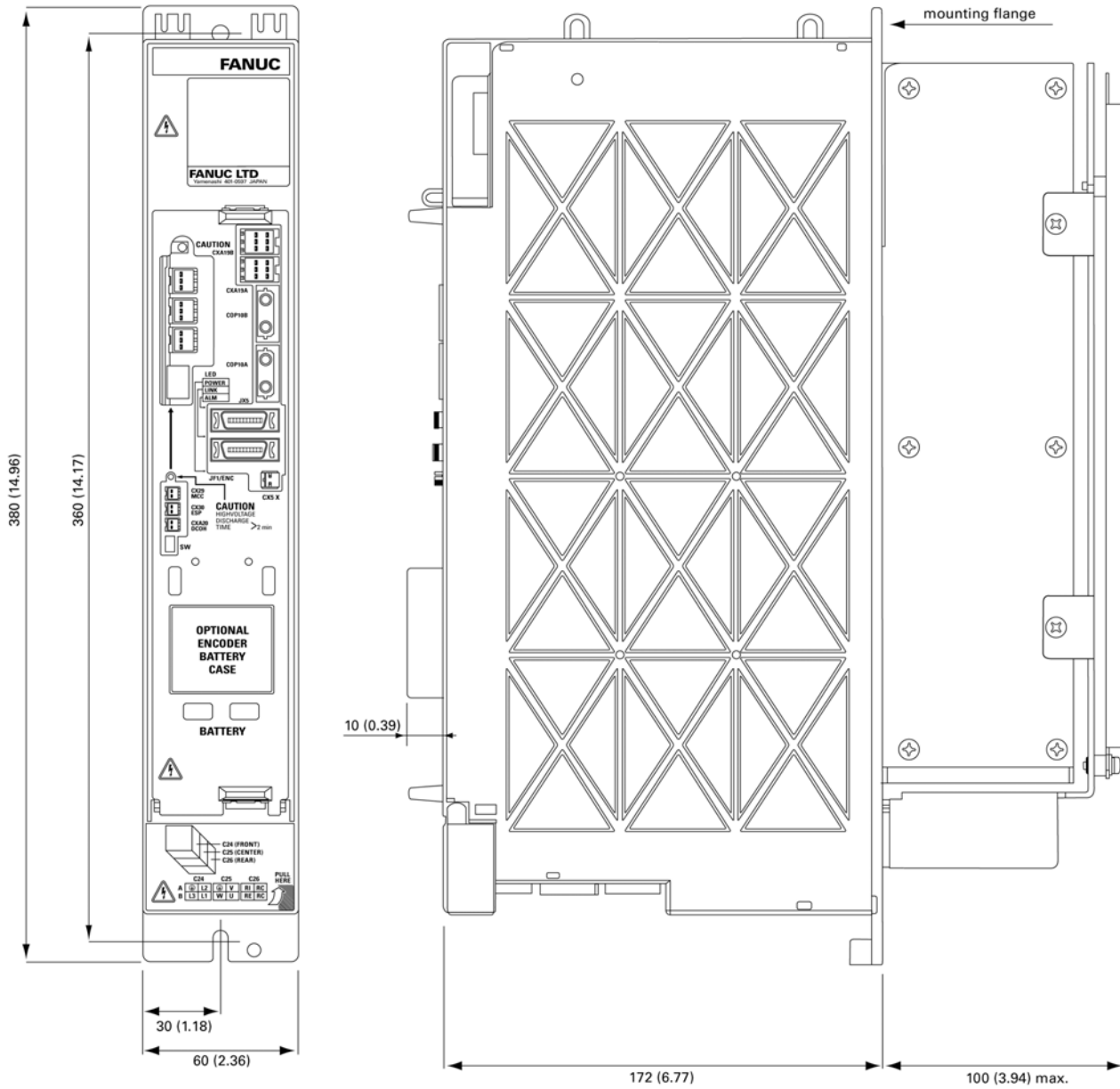

Figure III-11. External Dimensions of β SVM1-40i, β SVM1-10HVi and β SVM1-20HVi Amplifiers

19.5 Absolute Encoder Battery Options

All β is and β HVi Series servomotors feature a built-in encoder that can be used in either incremental or absolute mode. To utilize the absolute capability, an optional encoder battery pack must be installed. This pack allows the encoder's position information to be maintained so that the machine does not need to be re-referenced to a home position every time power is restored to the servo system.

The encoder for β is 0.4 to 22 Nm motors and all β HVi motors contains an integral capacitor that will maintain the encoder backup voltage for approximately 10 minutes. This allows battery change without loss of absolute position data.

There are two encoder battery backup options for the β i and β HVi Series amplifiers. A snap-on lithium battery pack that will support a single amplifier or a panel mounted battery pack for up to four amplifiers that uses standard D cell alkaline batteries.

For optimal panel space utilization, a small lithium battery pack IC800BBK021 is available that snaps onto the β i and β HVi Series amplifiers housing (see figure below). An integral pigtail cable plugs directly into the CX5X connector on the faceplate of the amplifier. One battery is required for each β i or β HVi Series amplifier. The lithium battery service life is approximately 2 years.

The Absolute Encoder Battery Kit (IC800BBK021) contains the following:

- Qty 1 - Battery (ZA06B-6093-K001)
- Qty 1 - Battery Holder (ZA06B-6093-K002)

Connection Method for Single Amplifiers

(IC800BBK021 for use with a single amplifier)

Installation

1. Make sure 24V control power is applied to the amplifier (if trying to hold position on an existing system)
2. Place system in an E-stop condition
3. Remove AC power from the amplifier
4. Remove the old battery (if applicable)
5. Place battery into plastic cover
6. Snap cover onto amplifier housing
7. Attach battery cable to amplifier CX5X connector as indicated in diagram making sure polarity is correct.

Note

- Do not attempt to connect multiple amplifiers to one IC800BBK021 battery kit.
- Replacement CX5 battery connectors are available as kit number ZA06B-6093-K303

Servo Products Specification Guide

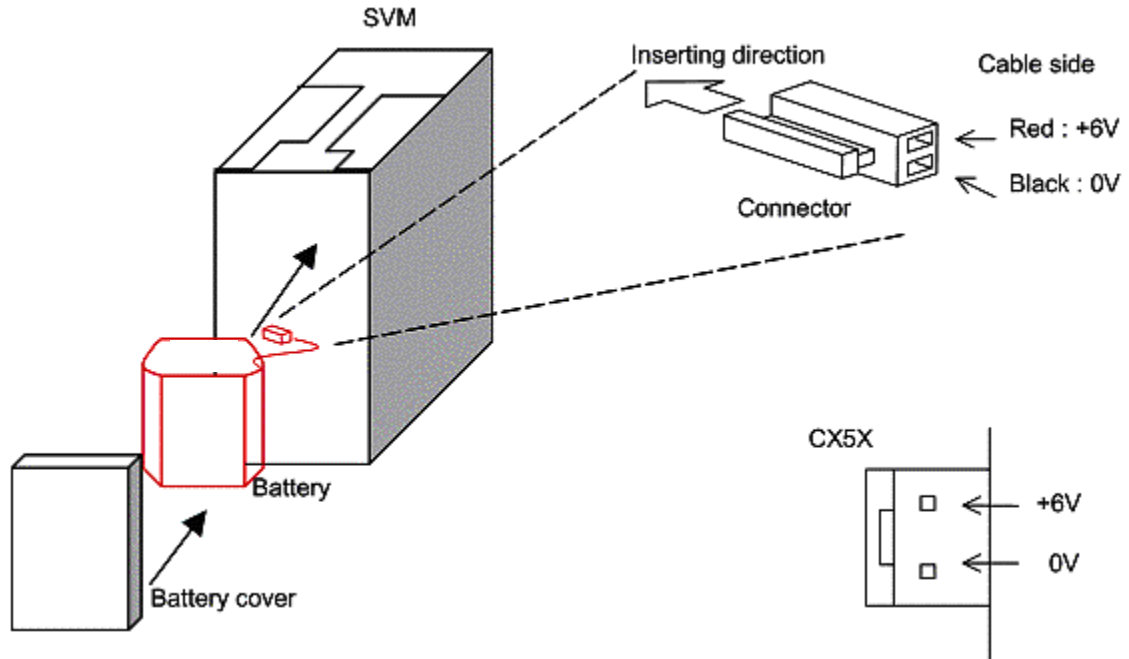

β SVM1-20i Amplifier

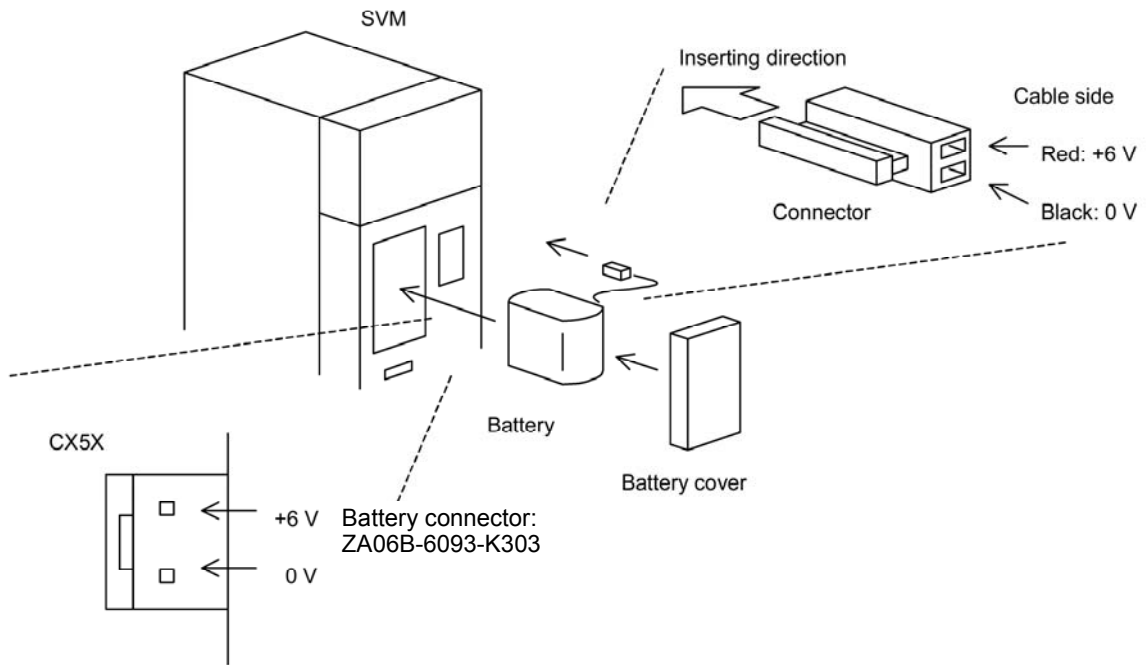

β SVM1-40i, β SVM1-10HVi and β SVM1-20HVi Amplifiers

Figure III-12. Installing the IC800BBK021 Absolute Encoder Battery Pack (One-Axis)

Connection Method for Multiple Amplifiers

To utilize the absolute capability for multiple amplifiers (β SVM1-20i, β SVM1-40i, β SVM1-10HVi or β SVM1-20HVi) the IC800ABK001 panel mounted battery pack must be installed.

The Absolute Encoder Battery Kit (IC800ABK001) contains the following:

- One battery holder (ZA06B-6050-K060)
- Four D-cell, alkaline batteries (ZA98L-0031-0005)

One kit provides battery backup for up to four absolute encoders. The user is responsible for manufacturing the cable used to connect the battery pack to the amplifier. The battery connection is made to the CXA19B connector on the last amplifier in the sequence supported by the battery pack. Terminals CXA19B-B3 (6V) and CXA19B-A2 (0V) are used and wire should be 0.3 mm² minimum cross sectional area. The battery power is distributed to the other amplifiers in the sequence by daisy chaining the CXA19A connections to the CXA19B connections on adjacent amplifiers. See Section 24: β i and β HVi Series Servo System Connection for more detail.

The battery service life is approximately one year and we recommend a yearly replacement schedule.

The IC800ABK001 battery pack is panel-mounted and requires a cutout in the mounting surface. Mounting dimensions and terminal designations are shown below.

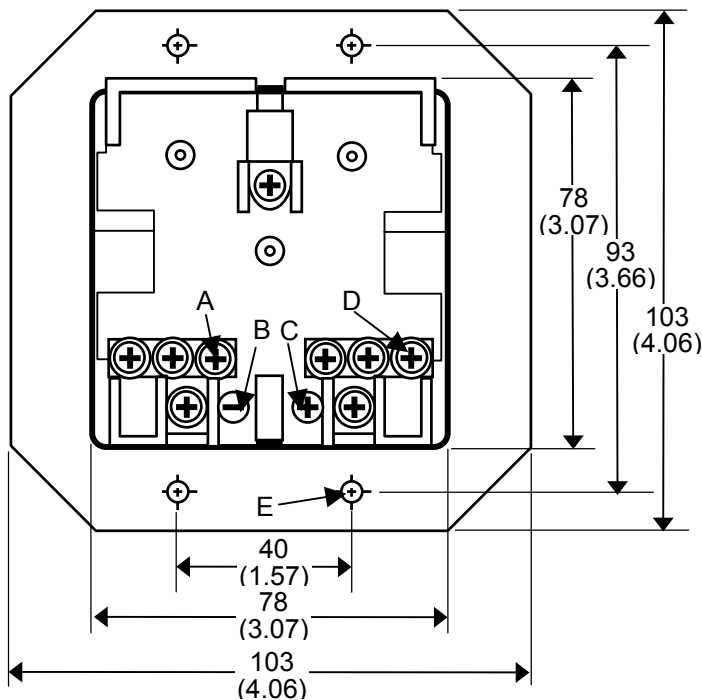

All dimensions in mm (in)

| | |
|---|---|
| A | 3-M3 negative terminal |
| B | Negative terminal indication |
| C | Positive terminal indication |
| D | 3-M3 positive terminal |
| E | 4- \varnothing 4.3 (0.169) mounting holes |

Figure III-13. Absolute Encoder Battery Pack IC800ABK001 (up to Four Axes)

Section 20: Installation Guidelines

This section includes environmental requirements, motor and amplifier dimension drawings and information on ensuring noise protection and selecting a ground fault interrupter.

20.1 β is and β HVi Motor Environmental Requirements

The servomotor must be installed in a location that satisfies the following environmental conditions:

Table III-12. Servo Motor Environmental Conditions

| Condition | Description |
|------------------------|--|
| Ambient temperature | The ambient temperature should be 0°C to 40°C. When operating the motor at a temperature higher than 40°C, it is necessary to de-rate the output power so that the motor's and the encoder's temperature rating is not exceeded. |
| Ambient humidity | Should be 80% RH (relative humidity) or less, non-condensing |
| Vibration | When installed in a machine, the vibration applied to the motor must not exceed 5G. |
| Altitude | No more than 1,000 m (3,300 ft) above sea level. |
| Drip-Proof Environment | The motors have a drip-proof structure that complies with IP65 of the IEC standard. Nevertheless, to ensure long-term performance, the motor surface should be protected from solvents, lubricants, and fluid spray. A cover should be used when there is a possibility of wetting the motor surface. Also, to prevent fluid from being led to the motor through the cable, put a drip loop in the cable when the motor is mounted. Finally, turn the motor connector sideways or downward as far as possible. If the cable connector will be subjected to moisture, it is recommended that an R class or waterproof plug be used. For additional information, see GE Fanuc publication <i>Servo and Spindle Motors Exposed to Liquids</i> , GFK-1046. |

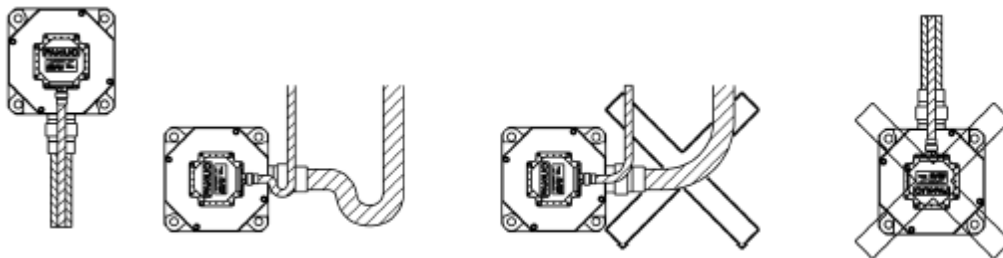

Figure III-14. Motor Installation for Drip-Proof environment

20.2 β is & β HVi Servo Amplifier Environmental Requirements

The servo amplifier must be installed in a location that satisfies the environmental conditions identified in the table below.

Table III-13. Servo Amplifier Environmental Conditions

| Condition | Description |
|-------------------------|---|
| Ambient temperature | 0°C to 55°C (operating). -20°C to 60°C (storage and transportation). |
| Temperature fluctuation | Within 1.1°C/min. |
| Humidity | 90% RH (non-condensing) or lower. |
| Altitude | No more than 1000 m (3,300 ft) above sea level. |
| Vibration | No more than 0.5 G during operation. |
| Atmosphere | The circuitry and cooling fins must not be exposed to any corrosive and conductive vapor or liquid. |

The amplifier must be installed in a cabinet that protects it from contaminants such as dust, coolant, organic solvents, acid, corrosive gas, and salt. Adequate protection must also be provided for applications where the amplifier could be exposed to radiation, such as microwave, ultraviolet, laser light, or x-rays.

To adequately protect the amplifier, you must ensure that:

- Contaminants such as dust and fluid cannot enter through the air inlet or outlet.
- The flow of cooling air is not obstructed.
- The amplifier can be accessed for inspection.
- The amplifier can be disassembled for maintenance and later reinstalled.
- There is sufficient separation between the power and signal lines to avoid interference. Noise protection should be provided.

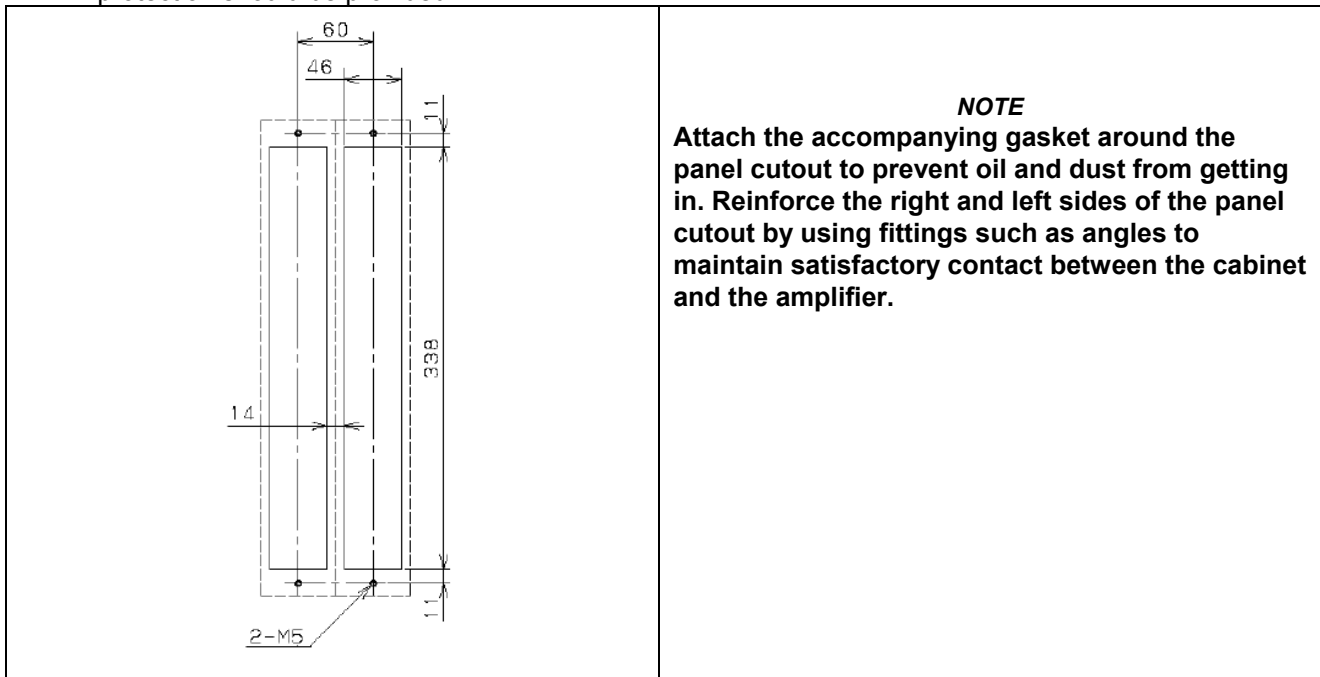

Figure III-15. Panel Cut-out Drawing for Through-Cabinet Mounting of the β SVM1-40i, β SVM10HVi and β SVM1-20HVi Amplifiers

20.3 β i and β HVi Amplifier Heat Dissipation and Maintenance Clearance

The amplifier may contain a cooling fan that forces air through the unit. Allow for adequate clearance for airflow when installing the amplifier using the recommended distances shown in the drawings below. If possible, do not mount amplifiers one above the other unless they are staggered to prevent the heated exhaust of the lower unit from flowing over the upper unit.

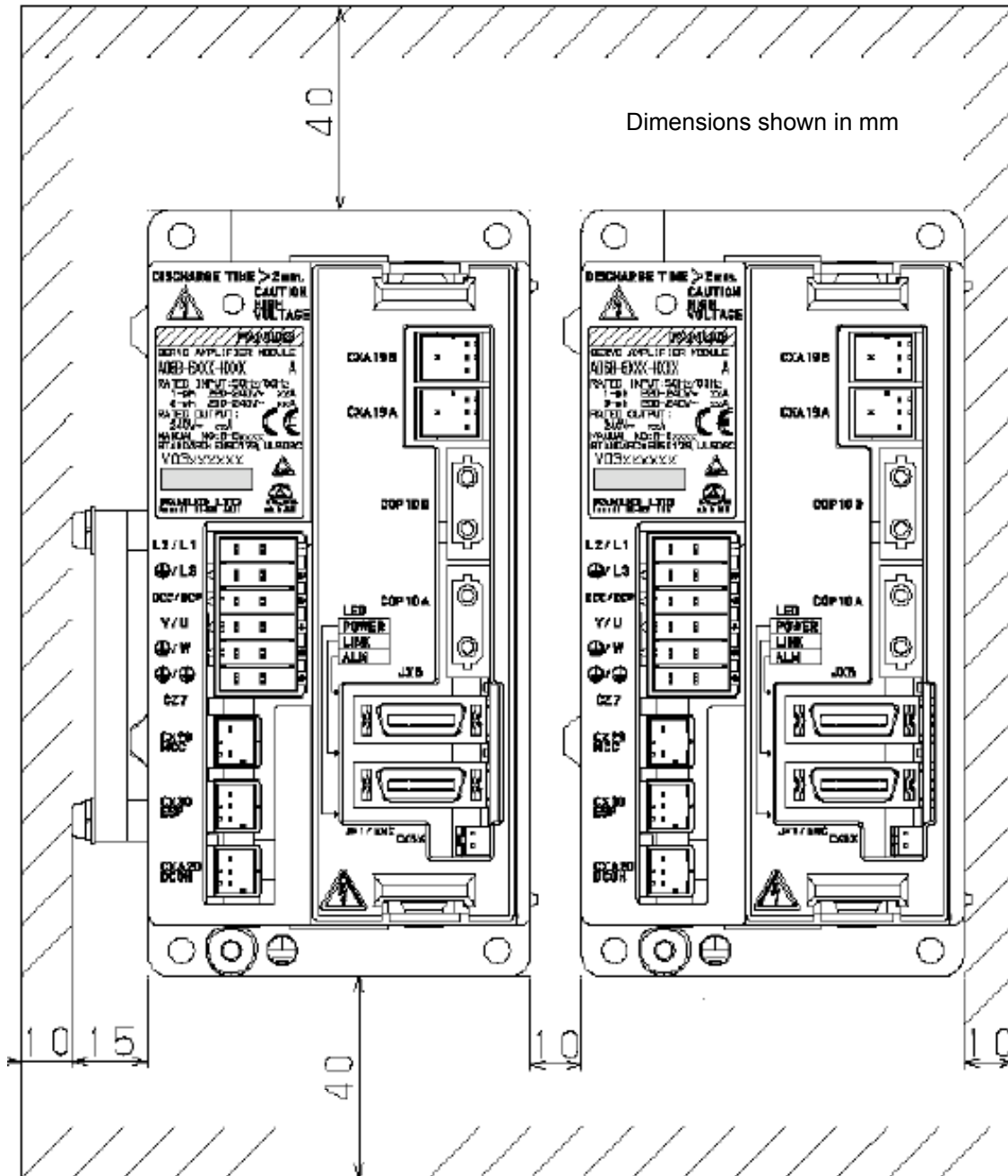

Figure III-16. Maintenance Clearance for Amplifier β SVM1-20i

Servo Products Specification Guide

Dimensions shown in mm

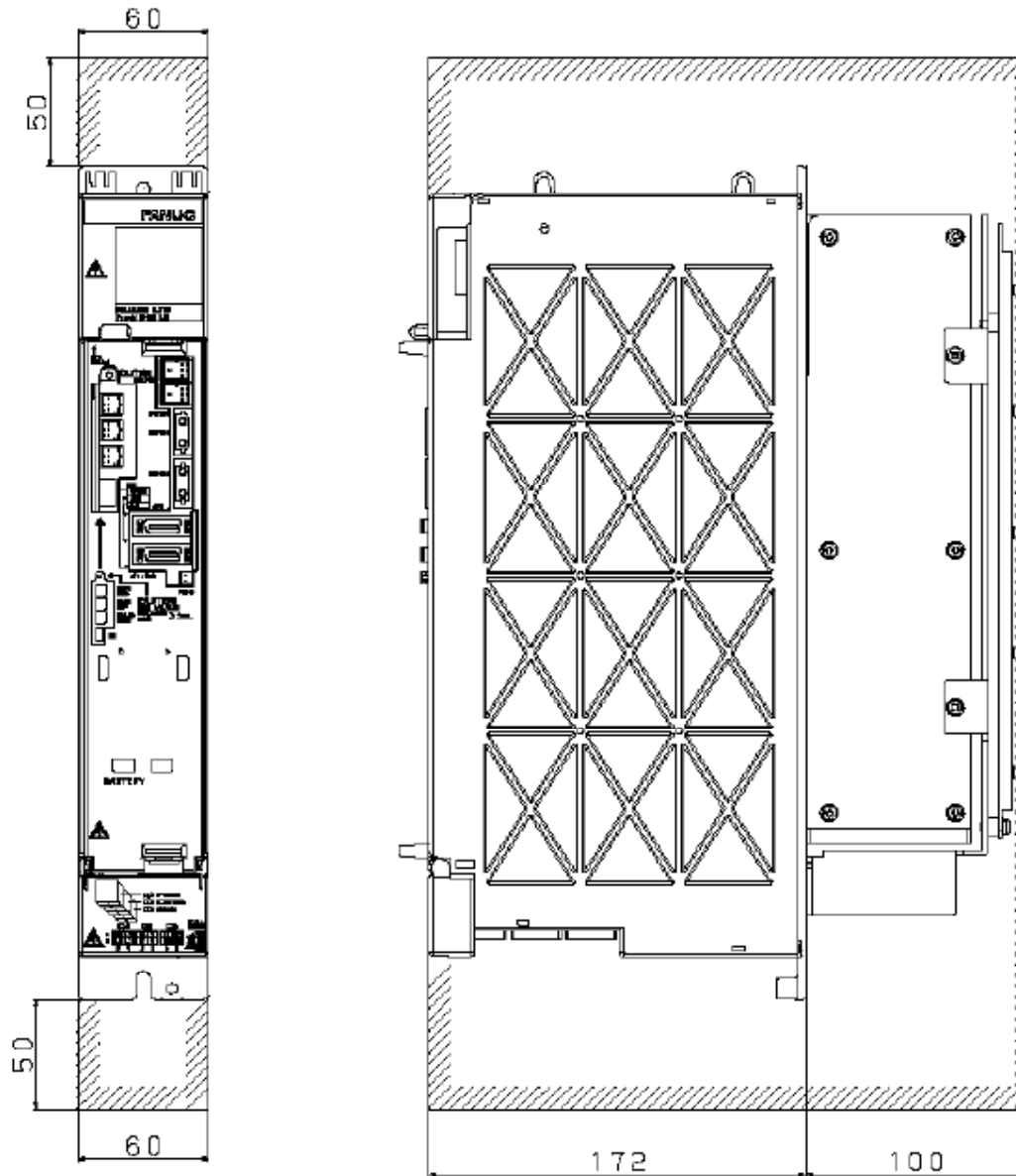

Figure III-17. β i Series β SVM1-40i, β SVM1-10HVi and β SVM1-20HVi Amplifier Maintenance Clearances

Section 21: Heat Dissipation

Table III-14 identifies worst-case heat dissipation values for each amplifier. These values may be used to determine heat load for sizing enclosures and cooling equipment. Heat dissipation for external regeneration resistors depends on the application and is calculated in 23.7, Step 5.

The total heat dissipation is a function of the amplifier base dissipation (a) plus the amplifier heat coefficient (K) times the heat generated by RMS stall current flowing through the servo motor (b).

$$\text{Total heat dissipation Watts} = a + (K * b)$$

Table III-14. In Cabinet Heat Dissipation

| <i>Amplifier</i> | <i>Catalog #</i> | <i>Amplifier base heat dissipation (a)</i> | <i>Amplifier heat coefficient (K)</i> | <i>Motor Model</i> | <i>Motor Current (b) [Arms]</i> | <i>Total heat dissipation [Watts]</i> |
|------------------|------------------|--|--|--------------------|---------------------------------|---------------------------------------|
| βSVM1-20i | ZA06B-6130-H002 | 20 watt | 7.7 | β0.4/5000is | 3.6 | 47.7 |
| | | | | β0.5/6000is | 2.9 | 42.3 |
| | | | | β1/6000is | 2.7 | 40.8 |
| | | | | β2/4000is | 3.3 | 45.4 |
| | | | | β4/4000is | 4.7 | 56.2 |
| | | | | β8/3000is | 6 | 66.2 |
| βSVM1-40i | ZA06B-6130-H003 | 20 watt | 7.1 (heat sink in cabinet) | β12/3000is | 10.2 | 92.4 |
| | | | | β22/2000is | 11.3 | 100.2 |
| | | | 1.4 (heat sink external to cabinet) | β12/3000is | 10.2 | 34.2 |
| | | | | β22/2000is | 11.3 | 35.8 |
| βSVM1-10HVi | ZA06B-6131-H001 | 20 watt | 10.8 (heat sink in cabinet) | β2/4000 HVis | 1.6 | 37.3 |
| | | | | β4/4000 HVis | 2.3 | 44.8 |
| | | | | β8/3000 HVis | 3.0 | 52.4 |
| | | | 2.2 (heat sink external to cabinet) | β2/4000 HVis | 1.6 | 23.5 |
| | | | | β4/4000 HVis | 2.3 | 25.1 |
| | | | | β8/3000 HVis | 3.0 | 26.6 |
| βSVM1-20HVi | ZA06B-6131-H002 | 20 watt | 11.1 (heat sink in cabinet) | β12/3000 HVis | 5.1 | 76.6 |
| | | | | β22/2000 HVis | 5.6 | 82.2 |
| | | | 2.2 (heat sink external to cabinet) | β12/3000 HVis | 5.1 | 31.2 |
| | | | | β22/2000 HVis | 5.6 | 32.3 |

Section 22: Noise Protection

22.1 Separation of Signal and Power Lines

When routing signal and power lines, the signal lines must be separated from the power lines to ensure best noise immunity. The table below lists the types of cables used:

Table III-15. Servo amplifier signal line separation

| Group | Signal | Action |
|-------|--|--|
| A | Amplifier input power line, motor power line, MCC drive coil | Separate these cables from those of group B by bundling them separately* or by means of electromagnetic shielding**. Attach a noise suppressor (spark arrester) to the MCC drive coil. |
| B | Cable connecting control unit with servo amplifier and serial encoder feedback cable | Separate these cables from those of group A by bundling them separately or by means of electromagnetic shielding**. In addition, shielding must be provided. |

* The bundle of group A cables must be separated from the bundle of group B cables by at least 10 cm.

** Electromagnetic shielding involves shielding groups from each other by means of a grounded metal (steel) plate.

22.2 Grounding

A typical machine has three separate grounds:

- **Signal Ground:** Provides the reference potential (0 V) for the electrical signal system.
- **Frame Ground:** Ensures safety and shields external and internal noise.
- **System Ground:** Connects each unit and the inter-unit frame ground system to earth ground.

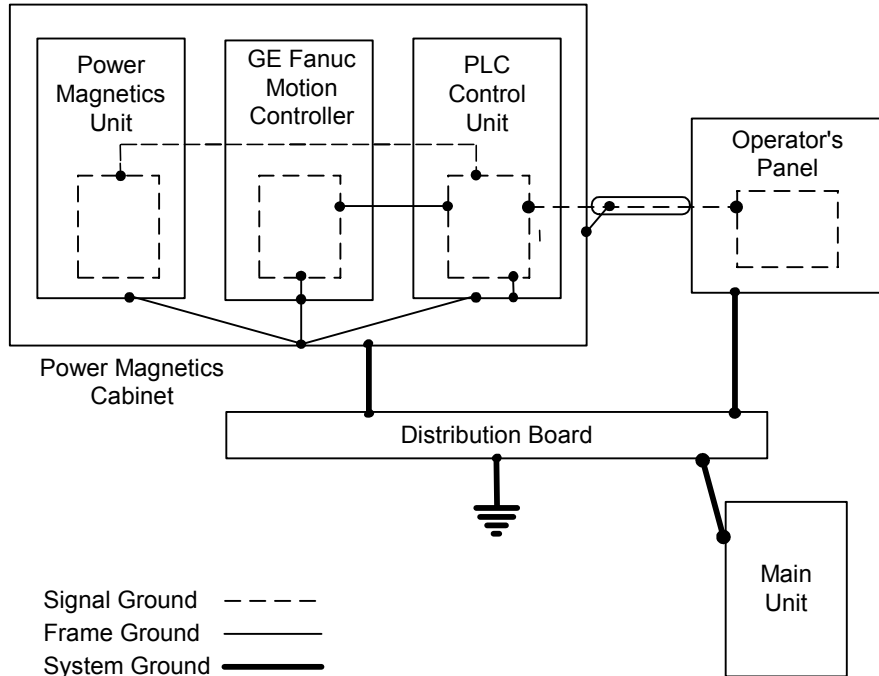

Figure III-18. Ground System

Servo Products Specification Guide

Notes on the ground system wiring:

- The ground resistance of the system ground must not exceed 100 ohms (Class-3 ground).
- System ground connection cables must have a sufficiently large cross-sectional area to enable them to safely carry the current that will arise in the event of a problem such as a short-circuit (in general, a cross-sectional area no less than that of the AC power line must be provided).
- The system ground connection cable must be integrated with the AC power line such that power cannot be supplied if the ground wire is disconnected.
- The SVM1-20i CZ7-3 motor power connector servo motor frame ground connection on pin A2 should always be installed.
- The motor frame must be referenced to earth ground with a class 3 (100 ohms or less) system ground. Use an ohmmeter to measure the resistance from the servomotor frame to a known earth ground rod or grid. When using the 20 amp amplifier (SVM-20i), the servo motor frame ground connection on connector CZ7-3 pin A2 should always be installed. The frame-to-ground resistance should be within 1 to 2 ohms.
In a high noise environment, installing a ground wire on the motor frame and routing it directly to the nearest available earth ground can improve noise immunity. Some servo motors have a tapped hole on the frame or a blind hole that can be tapped. For smaller motors, connect to the motor mounting bolts.
- The Motor Power cable should not be a shielded cable. If a custom built cable with shield was used for motor power, lift the shield connection at both ends of the cable. If a shield is attached, especially at the motor end, it acts as an antenna to couple noise into the encoder.
- The Motor Feedback cable should have the Z44B295864-001 Grounding Bar and one ZA99L-0035-001 Grounding Clamp per axis installed near the amplifier. Confirm that the grounding bar is referenced to earth ground with a class 3 (100 ohms or less) system ground. Use an ohmmeter to measure the resistance from the grounding bar frame to a known earth ground rod or grid. The frame to ground resistance should be within 1 to 2 ohms.
In a high noise environment, installing a ferrous bead on the feedback cable within a short distance of the amplifier connector can also improve noise immunity.
- Separation of Motor Power and Motor Feedback cables: Group A signals (Amplifier main AC power, Motor Power Cable and MCC drive coil) signals must be separated from Group B signals (Motor Feedback cable) by at least a 10cm distance. Do not tie Group A and B signals together with cable ties or wraps at any point. An alternative is to separate these two groups by means of a grounded metal (steel) plate.
- The MCC relay used to switch the three-phase AC main power to the amplifier should have an appropriate noise (spark arrester) on its drive coil.
- The 24VDC power supply used to supply the logic power to the amplifiers should be a regulated supply free of excessive noise. If possible examine the DC voltage with an oscilloscope for noise. If a 24 VDC motor-mounted holding brake is used, it should not use the same power supply as the control logic power.

Servo Products Specification Guide

- An AC line filter is recommended to suppress high frequency line noise on the amplifier main power lines. When an isolation transformer is used to convert AC main power to amplifier input power levels, the AC line filter is not required. GE Fanuc supplies an acceptable three-phase line filter sized for 5.4KW or 10.5KW especially for this purpose. This filtered AC main power should not be shared with other equipment in the panel, especially with devices such as inverter drives or motor starters that have high power consumption.
- Amplifier Chassis Ground must be referenced to earth ground with a class 3 (100 ohm or less) system ground. User an ohmmeter to measure the resistance from the amplifier frame to a known earth ground rod or grid. A tapped and threaded hole is provided on the amplifier frame for this purpose.
- AC Main PE Ground is supplied in accordance to local code practices and may vary, depending on AC power distribution in the facility. In general the PE ground should be referenced to an earth ground and not indicate common mode voltage to the instrumentation earth ground.

22.3 Encoder Feedback Cable Grounding

The β i Series motor encoder feedback cable shielding should be grounded by the method shown below. This cable clamp treatment provides both cable support (strain relief) and proper grounding of the shield. To ensure stable system operation, the cable clamp method is recommended. Partially peel back the cable sheath to expose the shield. Push the clamp (ZA99L-0035-0001) over the exposed shield and insert the clamp hooks into slots on the grounding bar (Z44B295864-001). Tighten the clamp to secure cable and complete the ground connection. The grounding bar must be attached to a low impedance earth ground.

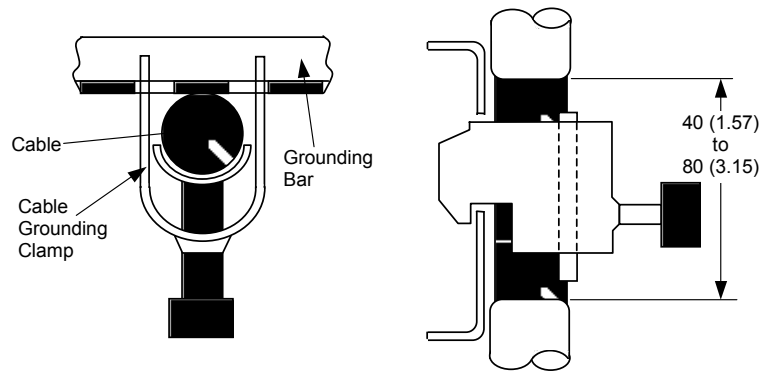

Figure III-19. Cable Grounding Clamp Detail

Note: The grounding bar should be located as close as possible to the amplifier to minimize cable length between amplifier and grounding bar. Observe recommended maintenance clearance.

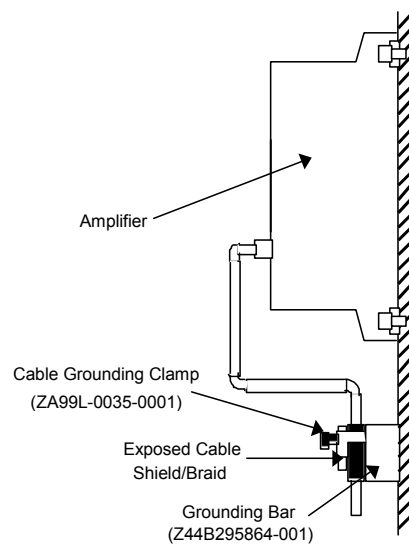

Figure III-20. Feedback Cable Shield Grounding System

Section 23: β i and β HVi Servo System Power Requirements

This section provides information about AC and DC amplifier power as well as the discharge of regenerative power.

23.1 Power Line Protection

A circuit breaker, electromagnetic contactor, and AC line filter or transformer should be installed as part of your β i and β HVi Series Servo system. GE Fanuc provides the AC line filter as an option. The transformer, circuit breaker, and electromagnetic contactor, however, are user-supplied components. In European countries where power sources are 380 to 400 VAC and neutral grounded, it is necessary to install a transformer or supply single-phase power for the β i Series amplifiers.

The same incoming AC control components can be used to provide power to multiple amplifiers, as long as the components are rated for the current and power drawn by the sum of all of the amplifiers.

23.2 AC Line Filter

An AC line filter is recommended to suppress the influences of high-frequency input line noise on the drive power supply. When an isolation-type power transformer is used because a power supply voltage within the specified range is not available, an AC line filter is not required.

If two or more servo amplifiers are connected to one AC line filter, the total continuous output rating of all connected servo amplifiers should be kept below the continuous output rating of the AC line filter. The continuous output rating for the various servos are shown below.

Table III-16. β is Servo Motor Continuous Output Rating at Low Line of 200 VAC

| <i>Motor</i> | <i>Continuous Output Rating</i> | <i>Motor</i> | <i>Continuous Output Rating</i> |
|--------------------|---------------------------------|---------------------|---------------------------------|
| β 0.4/5000is | 0.13 KW | β 2/4000HVis | 0.5 KW |
| β 0.5/6000is | 0.2 KW | β 4/4000HVis | 0.75 KW |
| β 1/6000is | 0.4 KW | β 8/3000HVis | 1.2 KW |
| β 2/4000is | 0.5 KW | β 12/3000HVis | 1.8 KW |
| β 4/4000is | 0.75 KW | β 22/2000HVis | 2.5 KW |
| β 8/3000is | 1.2 KW | | |
| β 12/3000is | 1.8 KW | | |
| β 22/2000is | 2.5 KW | | |

If your installation must be EMC compliant, verify that the use of an AC line filter fully satisfies the EMC requirements. You may need to select and install a user-supplied noise filter to meet EMC requirements.

AC line filters are available for GE Fanuc servo amplifiers:

| <i>AC Line Filter</i> | <i>Use With</i> |
|-----------------------|------------------------|
| ZA81L-0001-0083#3C | β i Amplifiers |
| ZA81L-0001-0101#C | β i Amplifiers |
| ZA81L-0001-0168 | β HVi Amplifiers |
| ZA81L-0001-0169 | β HVi Amplifiers |

For AC line filter specifications and dimension drawings, refer to [Section 6.2](#).

23.3 Circuit Breaker Selection

To provide proper protection for the amplifier, use a circuit breaker rated at no more than 20 Amps (10A for VDE 1601 compliance for CE marking). Table III-17 will help you select the appropriate circuit breaker for your motion application.

Table III-17. Currents Drawn at Continuous Rated Output at Low Line of 200 VAC

| <i>Motor</i> | <i>Input Current 3-phase (Arms)</i> | <i>Input Current Single Phase (Arms)</i> |
|---------------------|---|--|
| $\beta 0.4/5000is$ | 0.7 | 1.4 |
| $\beta 0.5/6000is$ | 1.1 | 2.2 |
| $\beta 1/6000is$ | 2.1 | 4.3 |
| $\beta 2/4000is$ | 2.6 | 5.4 |
| $\beta 4/4000is$ | 3.9 | 8.1 |
| $\beta 8/3000is$ | 6.3 | 9.7 |
| $\beta 12/3000is$ | 9.4 | n/a |
| $\beta 22/2000is$ | 13.1 | n/a |
| $\beta 2/4000HVis$ | 1.2 | n/a |
| $\beta 4/4000HVis$ | 1.7 | n/a |
| $\beta 8/3000HVis$ | 2.7 | n/a |
| $\beta 12/3000HVis$ | 4.0 | n/a |
| $\beta 22/2000HVis$ | 5.6 | n/a |

Note:

When multiple amplifiers are connected to a single circuit breaker, select a breaker by multiplying the sum of the currents listed in Table 57HIII-17 by 0.6. (This factor attempts to compensate for applications where all axes are not demanding full power at the same time. In applications where all axes are running continuously or with high duty cycles, this factor must be increased to 1.)

Example: Connecting two $\beta 8/3000is$ motors operating on 3-phase power:
 $(6.3 + 6.3) \times 0.6 = 7.6$ Arms

A standard 10 Amp circuit breaker can be used.

During rapid motor acceleration, a peak current that is three times the continuous rating flows. Select a circuit breaker that does not trip when a current that is three times the continuous rating flows for two seconds.

23.4 Electromagnetic Contactor Rating

To prepare for incoming AC power, you must also select and install an appropriate electromagnetic contactor, based on the peak currents for the motors in your system. When multiple amplifiers are connected to a single circuit breaker, select a breaker based on the sum of the motor currents in Table III-17.

23.5 Incoming AC power

Table III-18. AC Power

| <i>Specification</i> | <i>βi Amplifiers</i> | <i>βHVi Amplifiers</i> |
|---|--|---|
| Voltage: 3-phase (+10%, -15%) 1-phase (+10%, -15%) | 200 VAC to 240 VAC 220 VAC to 240 VAC | 400—480 VAC n/a |
| Frequency | 50 Hz/60Hz \pm 2 Hz | 50 Hz/60Hz \pm 2 Hz |
| Voltage fluctuation during acceleration/deceleration | 7% or less | 7% or less |

AC Power Ratings

The power supply rating required when using multiple servo motors can be determined by summing the requirements of the individual motors.

The power supply ratings listed in Table III-19 are sufficient as continuous ratings. Note, however, that servo motor acceleration causes a current to momentarily flow that is approximately three times the continuous current rating.

When the power is turned on, a surge current of about 37A (when 264VAC is applied) flows for 20 msec.

Table III-19. Three-Phase Power Supply Ratings

| <i>Motor</i> | <i>Continuous Output Rating</i> | <i>Motor</i> | <i>Continuous Output Rating</i> |
|--------------------|---------------------------------|---------------------|---------------------------------|
| β 0.4/5000is | 0.13 KW | β 2/4000HVis | 0.8 KW |
| β 0.5/6000is | 0.2 KW | β 4/4000HVis | 1.2 KW |
| β 1/6000is | 0.4 KW | β 8/3000HVis | 1.9 KW |
| β 2/4000is | 0.5 KW | β 12/3000HVis | 2.8 KW |
| β 4/4000is | 0.75 KW | β 22/2000HVis | 3.9 KW |
| β 8/3000is | 1.2 KW | | |
| β 12/3000is | 1.8 KW | | |
| β 22/2000is | 2.5 KW | | |

23.6 Incoming DC Power

The β i and β HVi amplifiers require a 24 VDC power supply for amplifier control power. The user must supply this DC power supply.

The information in Table III-20 below will help you select the appropriate DC power supply for your motion application.

The same external DC power supply can be used to provide power to multiple amplifiers as long as the supply is rated for the sum of power drawn by all of the amplifiers. To daisy chain the amplifiers, add connections between connector CXA19A and CXA19B on adjacent amplifiers (see the connection diagrams for more details). Up to 8 amplifiers can be daisy chained when using 16 AWG wire or up to 6 amplifiers when using 20 AWG wire.

Table III-20. Amplifier DC Control Power Specifications

| <i>Specification</i> | <i>Description</i> |
|-------------------------------------|-----------------------|
| Input voltage | 24V DC ($\pm 10\%$) |
| Power supply rating (per amplifier) | 0.9 amps |

24 VDC Fuse Locations

The 24 VDC input is fused to protect the amplifier. The fuse labeled FU1 is located on the gray control board that plugs into the front of the amplifier. The diagrams below show the location on this board for each amplifier model. The replacement fuse part number is ZA06B-6073-K250 (Manufacturer: Daito LM32, DC48V, F3.2A).

A spare fuse is included with each β i series amplifier package (IC800BIK020, IC800BIK040, IC800BIHV010 or IC800BIHV020).

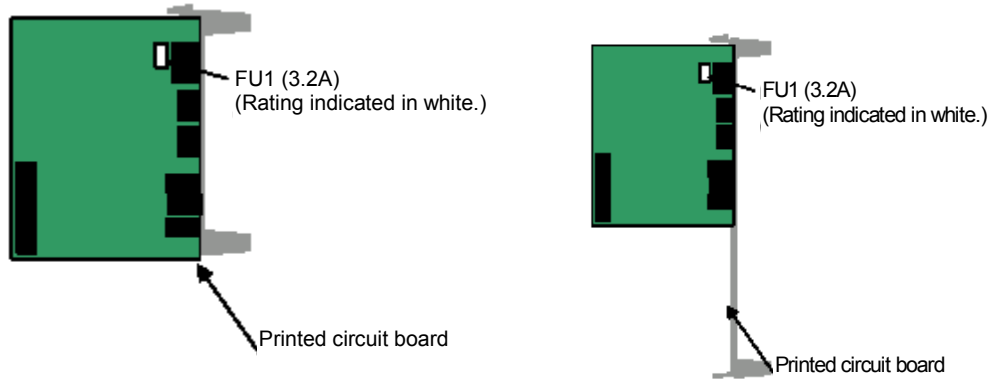

β SVM1-20i Amplifier

β SVM1-40i, β SVM1-10HVi and β SVM1-20HVi Amplifier

23.7 Discharging Regenerative Energy

Regenerative energy is normally created in applications with a high load inertia or frequent acceleration and deceleration. When decelerating a load, the stored kinetic energy of the load causes generator action in the motor causing energy to be returned to the amplifier. For light loads and low acceleration rates, the amplifier may be able to absorb this energy. Otherwise, an optional external regenerative discharge unit must be installed. This optional regeneration capability extends the functionality of the amplifier when working with loads and move profiles that require more capacity than is internal. Calculations shown later in this section can be used to determine the need for an external unit.

If the regenerative discharge unit overheats, a built-in thermostat is tripped, the external overheat alarm is issued, and the motor is stopped. If an external regenerative discharge unit is required, a separate unit must be installed for each amplifier. This component cannot be daisy-chained.

βSVM1-20i Amplifier Regeneration Options

For the βSVM1-20i amplifier, two optional separate 30-Ohm regenerative discharge units are available with power ratings of 100 W and 20 W. The 100 W unit (ZA06B-6130-H402) is panel-mounted, whereas the 20 W unit (ZA06B-6130-H401) mounts to the tapped holes on the side of the amplifier heat sink. The dimensions and connections for both units are shown in the connection section of this document.

NOTE

The amplifiers include an input on connector CXA20 (DCOH) for a normally closed thermal overload switch to protect the external regeneration resistor from overheating. If an external resistor is not used this input must be connected with a wire jumper or the amplifier will generate a fault and will not run.

βSVM1-40i Amplifier Regeneration Options

For this amplifier, two optional regeneration units are available. Both regeneration modules are panel mounted.

| <i>Regenerative Resistor Kit</i> | <i>No Fan Cooling</i> | <i>Fan Cooling (2 meters/sec air flow)</i> | <i>Fan Cooling (4 meters/sec air flow)</i> |
|----------------------------------|---------------------------------------|--|--|
| ZA06B-6089-H500 | 200 watt | 400 watt | 600 watt |
| ZA06B-6089-H713 | Incorporates a cooling fan in the kit | | 800 watt |

βSVM1-40i, βSVM1-10HVi and βSVM1-20HVi Switch Settings

There are four switches located on the front of the βSVM1-40i, βSVM1-10HVi and βSVM1-20HVi series servo amplifiers that configure the amplifier for the regenerative resistor option used. These switches should be set as described below before using these servo amplifiers.

WARNING:

If the switch settings are not correct it is possible to damage the regenerative resistor and it will be impossible to normally detect a regenerative overheat alarm.

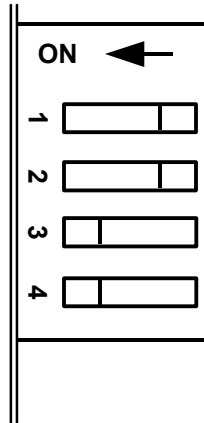

Figure III-21. βSVM1-40i, βSVM1-10HVi and βSVM1-20HVi Series Channel Switches

Switch Positions:

The switches are sequentially numbered 1, 2, 3, and 4 with the one at the top as switch 1. The ON position is on the left, and the OFF position is on the right.

Switch 1 Setting: Always set to OFF.

Switch 2 Setting: Always set to OFF.

Switches 3 and 4 Settings: The setting of these switches depends on the regenerative discharge resistance used. For the βSVM1-10HVi and βSVM1-20HVi, these are always ON.

Table III-21. Switch 3 and 4 Settings

| | <i>βSVM1-40i</i> | | <i>βSVM1-10HVi</i> | | <i>βSVM1-20HVi</i> | |
|----------------------------------|------------------|-----|--------------------|-----|--------------------|-----|
| | SW3 | SW4 | SW3 | SW4 | SW3 | SW4 |
| Regenerative Discharge Unit | ON | ON | ON | ON | ON | ON |
| Built-in (50 W) (Default) | ON | ON | N/A | N/A | N/A | N/A |
| External ZA06B-6089-H500 (200 W) | OFF | OFF | N/A | N/A | N/A | N/A |
| External ZA06B-6089-H713 (800 W) | OFF | OFF | N/A | N/A | N/A | N/A |

Regenerative Discharge Unit Dimensions

The separate regenerative discharge units are designed with a rear-mounted heat sink that extends through a hole in the mounting plate. The intent is that the user will construct a control cabinet with an internal air plenum into which the heat sinks for the β SVM1-40i amplifiers and associated regenerative discharge units will be mounted. This design eliminates most of the heat dissipation from these units inside the control cabinet.

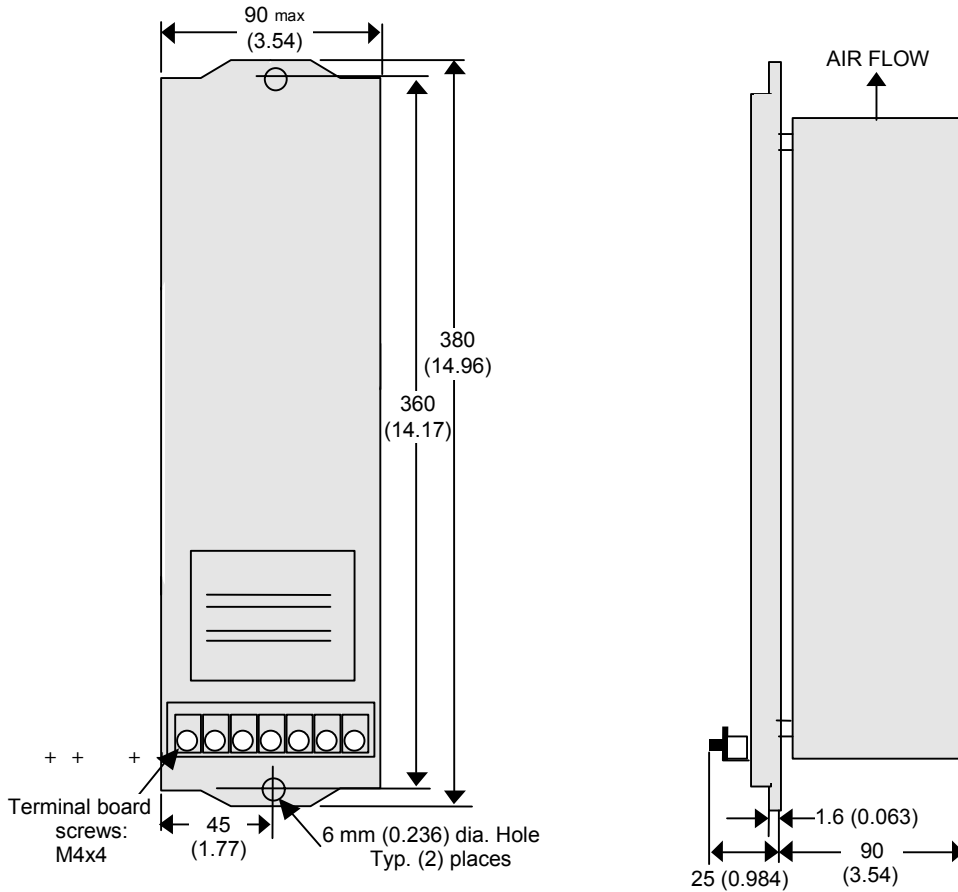

Figure III-22. 200 W Regenerative discharge unit (ZA06B-6089-H500), front and side views

Servo Products Specification Guide

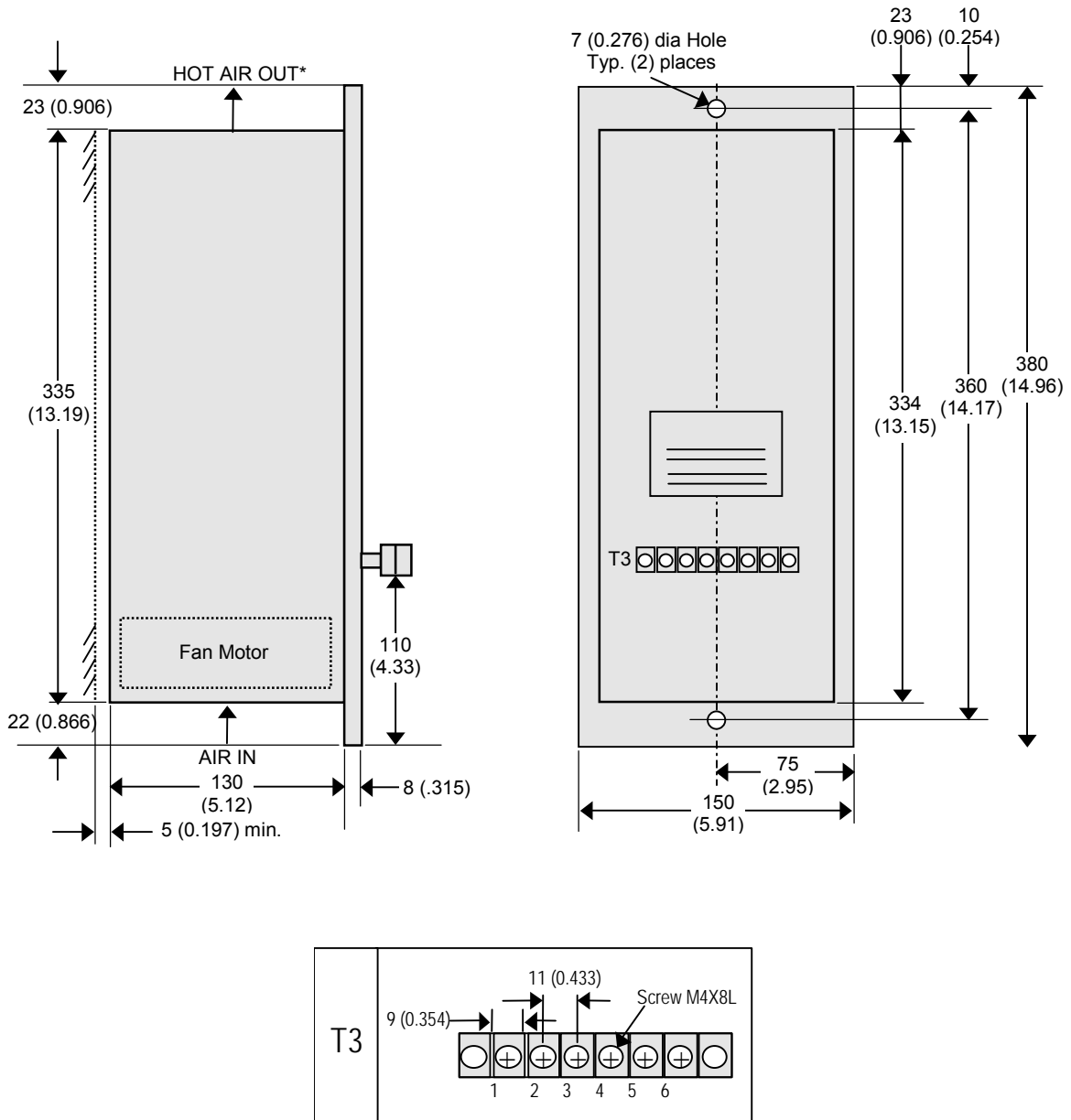
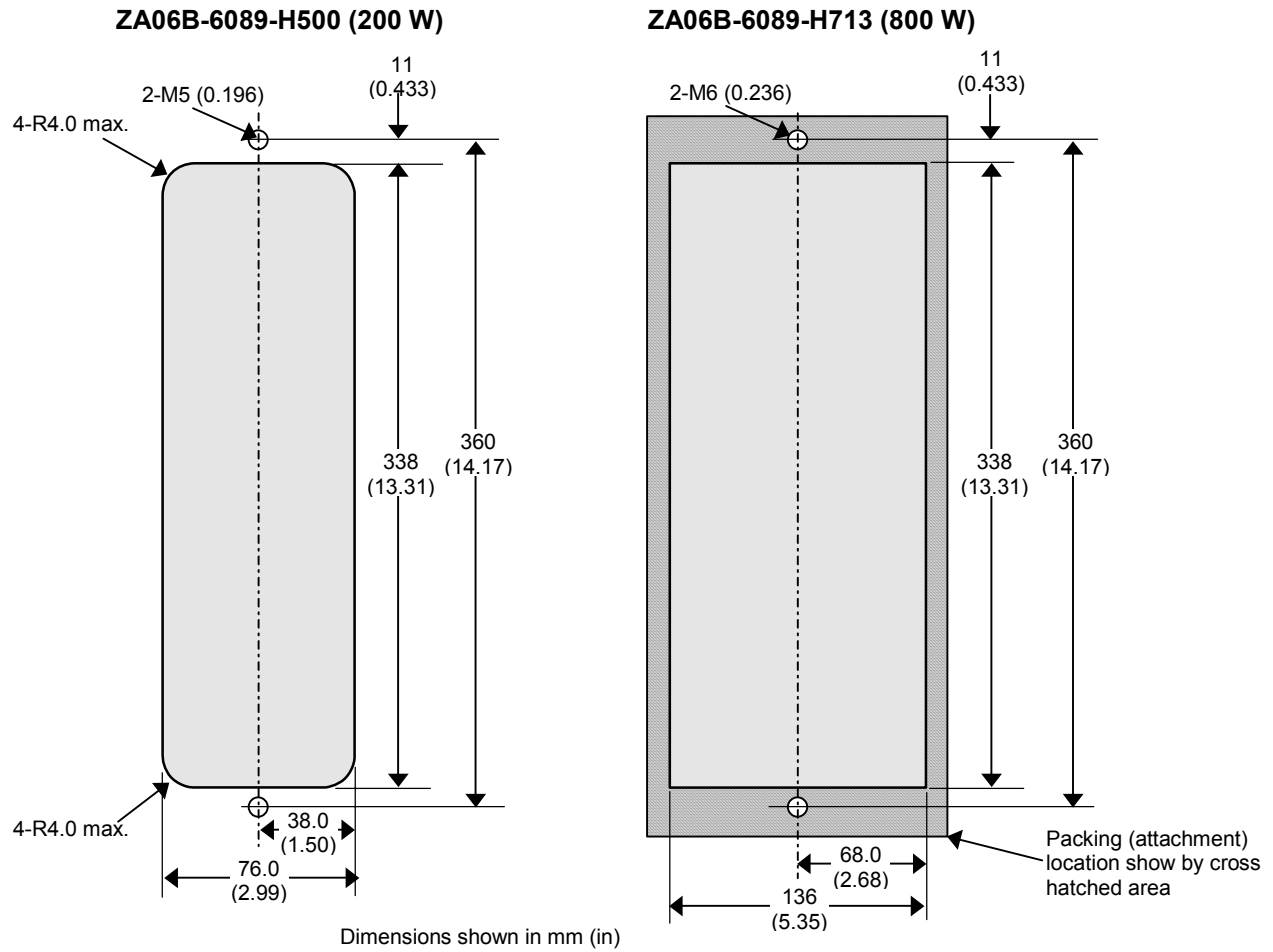

Figure III-23.800 W Regenerative Discharge Unit (ZA06B-6089-H713), Front, Side, and End Views with T3 Terminal Detail

Regenerative Discharge Unit Panel Cutout Dimensions

The panel cutouts necessary to mount the separate regenerative discharge units are shown below.



CAUTION:
 Attach packing (acrylonitrile-butadiene rubber or soft NBR) around the cutout to keep out oil and dust.

Figure III-24. Regenerative discharge unit panel cutout dimensions

Calculating the Average Regenerative Energy

Use the following calculation to determine the average regenerative energy that will be released in your application (ambient temperature is assumed not to exceed 55°C). Based on the calculations select either the internal regeneration or optional external regeneration resistor. The wattage rating of the selected resistor must exceed the average calculated regenerative energy from the equation below:

$$\begin{array}{rclcl} \text{Average} & & \text{Rotational Energy to} & & \text{Energy to be} & & \text{(only in vertical axis operation)} \\ \text{Regenerative} & = & \text{be Released during} & - & \text{Consumed Through} & + & \text{Vertical Energy to be Released} \\ \text{Energy (Joules)} & & \text{Deceleration} & & \text{Axis Friction} & & \text{During Downward Motion} \\ & & \text{(STEP 1)} & & \text{(STEP 2)} & & \text{(STEP 3)} \end{array}$$

STEP 1: Rotational Energy to be Released during Deceleration

$$= (6.19 \times 10^{-4}) \times (J_m + J_L) \times \omega_m^2 \text{ Joules}$$

where:

| | | |
|------------|---|-------------------------|
| J_m | Motor rotor inertia | (lb-in-s ²) |
| J_L | Load inertia converted to motor shaft inertia | (lb-in-s ²) |
| ω_m | Maximum motor speed at time of deceleration | (rpm) |

STEP 2: Energy to be consumed through Axis Friction

$$= (5.91 \times 10^{-3}) \times t_a \times \omega_m \times T_L \text{ where:}$$

| | | |
|------------|--|---------|
| ω_m | Motor speed during rapid traverse | (rpm) |
| t_a | Acceleration/deceleration duration during rapid traverse | (sec) |
| T_L | Axis friction torque (converted to motor shaft torque) | (lb-in) |

STEP 3: Vertical Energy to be Released During Downward Motion

(This term applies only in vertical axis operation)

$$= (1.182 \times 10^{-2}) \times T_h \times \omega_m \times \frac{D}{100} \text{ where:}$$

| | | |
|------------|--|---------|
| T_h | Upward supporting torque applied by the motor during downward rapid traverse | (lb-in) |
| ω_m | Motor speed during rapid traverse | (rpm) |
| D | Duty cycle of downward vertical operation during rapid traverse | (%) |

(Note: the maximum value of D is 50%. D assumes a smaller value)

STEP 4: Determine if a Regenerative Discharge Unit Is Required

Determine the Average Regenerative Energy using the equation in the beginning of this section.

When the average regenerative energy produced never exceeds the amounts indicated in the table below, a separate regenerative discharge unit is **not** required:

Servo Products Specification Guide

Table III-22. Maximum Allowable Regenerative Energy for Amplifiers

| <i>Amplifier</i> | <i>Max. Allowable Regen. Energy</i> |
|------------------|-------------------------------------|
| βSVM1-20i | 16 Joules |
| βSVM1-40i | 50 Watts |
| βSVM1-10HVi | 50 Watts |
| βSVM1-20HVi | 50 Watts |

If the calculated value exceeds the storage capability of the amplifier, then an external regenerative discharge unit is required (see Step 5).

STEP 5: Selecting a Regenerative Discharge Unit

If a separate regenerative discharge unit is required, the following calculation will determine the unit required:

Average Regenerative Power (W) = Average Regenerative Energy (Joules) $\times \frac{1}{F}$ where:

F = Deceleration duty (seconds) Example: deceleration once per 5 second cycle, F=5

Select a regenerative resistor with a rating that exceeds the average regenerative power.

Example:

Assume a horizontal axis using a β2/4000i motor ($J_m = 0.0002146 \text{ lb-in-s}^2$) that decelerates once every 6 seconds (F) for 0.2 seconds (t_a) with a maximum speed of 2000 RPM (ω_m). The machine inertia (J_L) is $0.00139 \text{ lb-in-s}^2$.

STEP 1: Rotational Energy = $(6.19 \times 10^{-4}) \times (0.0002146 + 0.00139) \times 2000^2 = 3.97 \text{ Joules}$

STEP 2: Assuming $T_L = 10 \text{ in-lb}$:

Friction Energy = $(5.91 \times 10^{-3}) \times 0.2 \times 2000 \times 10 = 23.64 \text{ Joules}$

Therefore:

STEP 4: Average Regenerative Energy = $3.97 - 23.64 = 27.61 \text{ Joules}$

Because the 27.61 Joules required is more than the 16 Joules allowed by the βSVM1-20i amplifier used with the β2i motor, an external regenerative resistor is required.

STEP 5: Since the application requires decelerations every 6 seconds, $\frac{1}{F} = \frac{1}{6}$

Average Regenerative Power = $27.61 \text{ Joules} / 6 \text{ seconds} = 4.6 \text{ W}$

Therefore, the 20 W resistor (ZA06B-6130-H401) is adequate for this application.

Section 24: β i and β HVi Series Servo System Connection

When planning your motion control system, it is important to determine how the different parts of the system connect together. This section provides information on the various cables and connectors required to connect the motor, amplifier and motion controller.

Many cables required for the system are available from GE Fanuc. Motor cable and connector kit part numbers for each motor and amplifier combination are shown in the table below.

Table III-23. β 0.4is to β 2is Motor Power, Feedback and Brake Cables and Connector Kits

| <i>Motor Model</i> | | <i>β0.4/5000is</i> | <i>β0.5/6000is</i> | <i>β1/6000is</i> | <i>β2/4000is</i> |
|---------------------------------|----------|-------------------------------------|-------------------------------------|-----------------------------------|-----------------------------------|
| <i>Amplifier Model</i> | | <i>βSVM1-20i</i> | <i>βSVM1-20i</i> | <i>βSVM1-20i</i> | <i>βSVM1-20i</i> |
| Power Cable | 7 M | CP8B-1WPB-0070-AZ | CP8B-1WPB-0070-AZ | CP8B-1WPB-0070-AZ | CP9B-0WPB-0070-AZ |
| | 14 M | CP8B-1WPB-0140-AZ | CP8B-1WPB-0140-AZ | CP8B-1WPB-0140-AZ | CP9B-0WPB-0140-AZ |
| Power Cable (Shielded) | 7 M | CP8B-1WEB-0070-AZ | CP8B-1WEB-0070-AZ | CP8B-1WEB-0070-AZ | CP9B-0WEB-0070-AZ |
| | 14 M | CP8B-1WEB-0140-AZ | CP8B-1WEB-0140-AZ | CP8B-1WEB-0140-AZ | CP9B-0WEB-0140-AZ |
| Feedback Cable (Right Angle) | 7 M | CFDA-7WPB-0070-AZ | CFDA-7WPB-0070-AZ | CFDA-7WPB-0070-AZ | CFDA-7WPB-0070-AZ |
| | 14 M | CFDA-7WPB-0140-AZ | CFDA-7WPB-0140-AZ | CFDA-7WPB-0140-AZ | CFDA-7WPB-0140-AZ |
| Feedback Cable (Straight) | 7 M | CFDA-0WPB-0070-AZ | CFDA-0WPB-0070-AZ | CFDA-0WPB-0070-AZ | CFDA-0WPB-0070-AZ |
| | 14 M | CFDA-0WPB-0140-AZ | CFDA-0WPB-0140-AZ | CFDA-0WPB-0140-AZ | CFDA-0WPB-0140-AZ |
| Brake Power Cable | 7 M | CB6N-5WPM-0070-AZ | CB6N-5WPM-0070-AZ | CB6N-5WPM-0070-AZ | Integrated with Power Cable |
| | 14 M | CB6N-5WPM-0140-AZ | CB6N-5WPM-0140-AZ | CB6N-5WPM-0140-AZ | Integrated with Power Cable |
| Motor Feedback Connector Kit | 90 Deg | ZA06B-6114-K204#E | ZA06B-6114-K204#E | ZA06B-6114-K204#E | ZA06B-6114-K204#E |
| | Straight | ZA06B-6114-K204#S | ZA06B-6114-K204#S | ZA06B-6114-K204#S | ZA06B-6114-K204#S |
| Motor Power/Brake Connector Kit | 90 Deg | N/A | N/A | N/A | ZA06B-6114-K220#E |
| | Straight | N/A | N/A | N/A | ZA06B-6114-K220#S |
| Motor Power Connector Kit | 90 Deg | ZA06B-6114-K230#E | ZA06B-6114-K230#E | ZA06B-6114-K230#E | N/A |
| | Straight | ZA06B-6114-K230#S | ZA06B-6114-K230#S | ZA06B-6114-K230#S | N/A |
| Motor Brake Connector Kit | 90 Deg | ZA06B-6114-K232#E | ZA06B-6114-K232#E | ZA06B-6114-K232#E | N/A |
| | Straight | ZA06B-6114-K232#S | ZA06B-6114-K232#S | ZA06B-6114-K232#S | N/A |

Servo Products Specification Guide

Table III-24. β 4is to β 22is Motor Power, Feedback and Brake Cables and Connector Kits

| <i>Motor Model</i> | | <i>β4/4000is</i> | <i>β8/3000is</i> | <i>β12/3000is</i> | <i>β22/2000is</i> |
|---------------------------------|----------|-----------------------------------|-----------------------------------|------------------------------------|------------------------------------|
| <i>Amplifier Model</i> | | <i>βSVM1-20i</i> | <i>βSVM1-20i</i> | <i>βSVM1-40i</i> | <i>βSVM1-40i</i> |
| Power Cable | 7 M | CP9B-0WPB-0070-AZ | CP3B-0WPB-0070-AZ | CP5B-0WPB-0070-AZ | CP6B-0WPB-0070-AZ |
| | 14 M | CP9B-0WPB-0140-AZ | CP3B-0WPB-0140-AZ | CP5B-0WPB-0140-AZ | CP6B-0WPB-0140-AZ |
| Power Cable (Shielded) | 7 M | CP9B-0WEB-0070-AZ | CP3B-0WEB-0070-AZ | CP5B-0WEB-0070-AZ | CP6B-0WEB-0070-AZ |
| | 14 M | CP9B-0WEB-0140-AZ | CP3B-0WEB-0140-AZ | CP5B-0WEB-0140-AZ | CP6B-0WEB-0140-AZ |
| Feedback Cable (Right Angle) | 7 M | CFDA-7WPB-0070-AZ | CFDA-7WPB-0070-AZ | CFDA-7WPB-0070-AZ | CFDA-7WPB-0070-AZ |
| | 14 M | CFDA-7WPB-0140-AZ | CFDA-7WPB-0140-AZ | CFDA-7WPB-0140-AZ | CFDA-7WPB-0140-AZ |
| Feedback Cable (Straight) | 7 M | CFDA-0WPB-0070-AZ | CFDA-0WPB-0070-AZ | CFDA-0WPB-0070-AZ | CFDA-0WPB-0070-AZ |
| | 14 M | CFDA-0WPB-0140-AZ | CFDA-0WPB-0140-AZ | CFDA-0WPB-0140-AZ | CFDA-0WPB-0140-AZ |
| Holding Brake Power Cable | 7 M | Integrated with Power Cable | CB4N-0WPM-0070-AZ | CB4N-0WPM-0070-AZ | CB4N-0WPM-0070-AZ |
| | 14 M | Integrated with Power Cable | CB4N-0WPM-0140-AZ | CB4N-0WPM-0140-AZ | CB4N-0WPM-0140-AZ |
| Motor Feedback Connector Kit | 90 Deg | ZA06B-6114-K204#E | ZA06B-6114-K204#E | ZA06B-6114-K204#E | ZA06B-6114-K204#E |
| | Straight | ZA06B-6114-K204#S | ZA06B-6114-K204#S | ZA06B-6114-K204#S | ZA06B-6114-K204#S |
| Motor Power/Brake Connector Kit | 90 Deg | ZA06B-6114-K220#E | N/A | N/A | N/A |
| | Straight | ZA06B-6114-K220#S | N/A | N/A | N/A |
| Motor Power Connector Kit | 90 Deg | N/A | ZA06B-6079-K812 | ZA06B-6079-K812 | ZA06B-6079-K815 |
| | Straight | N/A | ZA06B-6079-K811 | ZA06B-6079-K811 | ZA06B-6079-K814 |
| Motor Brake Connector Kit | 90 Deg | N/A | ZA06B-6114-K213#E | ZA06B-6114-K213#E | ZA06B-6114-K213#E |
| | Straight | N/A | ZA06B-6114-K213#S | ZA06B-6114-K213#S | ZA06B-6114-K213#S |

Table III-25. β 2HVis and β 4HVis Motor Power, Feedback and Brake Cables and Connector Kits

| <i>Motor Model</i> | | <i>β2/4000HVis</i> | <i>β4/4000HVis</i> |
|---------------------------------|----------|-------------------------------------|-------------------------------------|
| <i>Amplifier Model</i> | | <i>βSVM1-10HVI</i> | <i>βSVM1-10HVI</i> |
| Power Cable | 7 M | CP2I-0WPB-0070-AZ | CP2I-0WPB-0070-AZ |
| | 14 M | CP2I-0WPB-0140-AZ | CP2I-0WPB-0140-AZ |
| Power Cable (Shielded) | 7 M | CP2I-0WEB-0070-AZ | CP2I-0WEB-0070-AZ |
| | 14 M | CP2I-0WEB-0140-AZ | CP2I-0WEB-0140-AZ |
| Feedback Cable (Right Angle) | 7 M | CFDA-7WPB-0070-AZ | CFDA-7WPB-0070-AZ |
| | 14 M | CFDA-7WPB-0140-AZ | CFDA-7WPB-0140-AZ |
| Feedback Cable (Straight) | 7 M | CFDA-0WPB-0070-AZ | CFDA-0WPB-0070-AZ |
| | 14 M | CFDA-0WPB-0140-AZ | CFDA-0WPB-0140-AZ |
| Brake Power Cable | 7 M | Integrated with Power Cable | Integrated with Power Cable |
| | 14 M | Integrated with Power Cable | Integrated with Power Cable |
| Motor Feedback Connector Kit | 90 Deg | ZA06B-6114-K204#E | ZA06B-6114-K204#E |
| | Straight | ZA06B-6114-K204#S | ZA06B-6114-K204#S |
| Motor Power/Brake Connector Kit | 90 Deg | ZA06B-6114-K220#E | ZA06B-6114-K220#E |
| | Straight | ZA06B-6114-K220#S | ZA06B-6114-K220#S |
| Motor Power Connector Kit | 90 Deg | N/A | N/A |
| | Straight | N/A | N/A |
| Motor Brake Connector Kit | 90 Deg | N/A | N/A |
| | Straight | N/A | N/A |

Servo Products Specification Guide

Table III-26. β 8HVis to β 22HVis Motor Power, Feedback and Brake Cables and Connector Kits

| <i>Motor Model</i> | | <i>β8/3000HVis</i> | <i>β12/3000HVis</i> | <i>β22/2000HVis</i> |
|------------------------------------|----------|-------------------------------------|--------------------------------------|--------------------------------------|
| <i>Amplifier Model</i> | | <i>βSVM1-10HVi</i> | <i>βSVM1-20HVi</i> | <i>βSVM1-20HVi</i> |
| Power Cable | 7 M | CP3I-0WPB-0070-AZ | CP3I-0WPB-0070-AZ | CP4I-0WPB-0070-AZ |
| | 14 M | CP3I-0WPB-0140-AZ | CP3I-0WPB-0140-AZ | CP4I-0WPB-0140-AZ |
| Power Cable (Shielded) | 7 M | CP3I-0WEB-0070-AZ | CP3I-0WEB-0070-AZ | CP4I-0WEB-0070-AZ |
| | 14 M | CP3I-0WEB-0140-AZ | CP3I-0WEB-0140-AZ | CP4I-0WEB-0140-AZ |
| Feedback Cable (Right Angle) | 7 M | CFDA-3WPB-0070-AZ | CFDA-3WPB-0070-AZ | CFDA-3WPB-0070-AZ |
| | 14 M | CFDA-3WPB-0140-AZ | CFDA-3WPB-0140-AZ | CFDA-3WPB-0140-AZ |
| Feedback Cable (Straight) | 7 M | CFDA-0WPB-0070-AZ | CFDA-0WPB-0070-AZ | CFDA-0WPB-0070-AZ |
| | 14 M | CFDA-0WPB-0140-AZ | CFDA-0WPB-0140-AZ | CFDA-0WPB-0140-AZ |
| Brake Power Cable | 7 M | CB4N-0WPM-0070-AZ | CB4N-0WPM-0070-AZ | CB4N-0WPM-0070-AZ |
| | 14 M | CB4N-0WPM-0140-AZ | CB4N-0WPM-0140-AZ | CB4N-0WPM-0140-AZ |
| Motor Feedback Connector Kit | 90 Deg | ZA06B-6114-K204#E | ZA06B-6114-K204#E | ZA06B-6114-K204#E |
| | Straight | ZA06B-6114-K204#S | ZA06B-6114-K204#S | ZA06B-6114-K204#S |
| Motor Power/Brake Connector Kit | 90 Deg | N/A | N/A | N/A |
| | Straight | N/A | N/A | N/A |
| Motor Power Connector Kit | 90 Deg | ZA06B-6079-K812 | ZA06B-6079-K812 | ZA06B-6079-K815 |
| | Straight | ZA06B-6079-K811 | ZA06B-6079-K811 | ZA06B-6079-K814 |
| Motor Brake Connector Kit | 90 Deg | ZA06B-6114-K213#E | ZA06B-6114-K213#E | ZA06B-6114-K213#E |
| | Straight | ZA06B-6114-K213#S | ZA06B-6114-K213#S | ZA06B-6114-K213#S |

24.1 Connectors on the Motor Side

For the FANUC AC Servo Motor β is series, a TÜV-approved connector is used as the power line connector to meet the IEC60034 standard.

- The power connector for β 0.2is and β 0.3is is not drip proof.
- The power connectors for β 0.4is to β 4is are drip proof when engaged with the cable connector.
- As the power connectors for β 8is to β 22is, receptacle connectors, which are drip proof by themselves (when not engaged), are used as standard. The power connectors for β 8is and β 22is are compatible with MS standard round connectors, though they do not strictly conform to the MS standard.
- The signal connector for β 0.2is and β 0.3is is not drip proof.
- The signal connector for β 0.4is to β 22is is drip proof when engaged with the cable connector. (When the motor cable is not connected, the connector is drip proof when the protective cap mounted to the connector at shipment is installed.)

Servo Products Specification Guide

Table III-27. Connectors for β 0.2is and β 0.3is

| <i>Motor Type</i> | <i>For Power</i> | <i>For Signal</i> | <i>For Brake</i> |
|--------------------|------------------------|------------------------|-------------------------------|
| β 0.2/5000is | 3-179554-3 | 1-1318115-6 | Common to connector for power |
| β 0.3/5000is | (Tyco Electronics AMP) | (Tyco Electronics AMP) | |

Table III-28. Connectors for β 0.4iS to β 1iS

| <i>Motor Type</i> | <i>For Power</i> | <i>For Signal</i> | <i>For Brake</i> |
|---|------------------------------------|--|------------------------------------|
| β 0.4/5000is β 0.5/5000is β 1/5000is | 55618-0401 (MOLEX JAPAN Co., Ltd.) | JN2AS10UL1 (Japan Aviation Electronics Industry) | 55619-0401 (MOLEX JAPAN Co., Ltd.) |

Table III-29. Connectors for β 2iS, β 2HVis, β 4iS and β 4HVis

| <i>Motor Type</i> | <i>For Power</i> | <i>For Signal</i> | <i>For Brake</i> |
|-----------------------------------|----------------------------------|--|---------------------------------------|
| β 2/4000is β 4/4000is | 1473060-2 (Tyco Electronics AMP) | JN2AS10UL1 (Japan Aviation Electronics Industry) | Included in the power line connector. |

Table III-30. Connectors for β 8iS, β 8HVis, β 12iS and β 12HVis

| <i>Motor Type</i> | <i>For Power</i> | <i>For Signal</i> | <i>For Brake</i> |
|------------------------------------|---|--|--|
| β 8/3000is β 12/3000is | H/MS3102A18-10P-D-T(10) (Hirose Electric) | JN2AS10UL1 (Japan Aviation Electronics Industry) | JN2AS04MK2 (Japan Aviation Electronics Industry) |

Table III-31. Connectors for β 22iS and β 22HVis

| <i>Motor Type</i> | <i>For Power</i> | <i>For Signal</i> | <i>For Brake</i> |
|-------------------|---------------------------------------|---------------------------------------|---------------------------------------|
| β 22/2000is | JL04HV-2E22-22PE-BT | JN2AS10UL1 | JN2AS04MK2 |
| | (Japan Aviation Electronics Industry) | (Japan Aviation Electronics Industry) | (Japan Aviation Electronics Industry) |
| | | | |

CAUTION

1. The motors should be installed with their connector facing downward, if possible. When it is impossible to install a motor in this position, allow slack in the cable to keep liquids such as a dielectric fluid from going along the cable into the cable or motor. If there is a possibility that the motors and connectors will get wet, provide a cover to protect them.
2. If a motor is not connected to the earth ground through the machine (frame), connect the motor grounding point and the amplifier grounding point to absorb noise using a 1.25 mm² or larger conductor other than the grounding conductor in the power cable. Keep the grounding conductor as far from the power cable as possible.

24.2 Signal Connectors on the Cable Side (Models $\beta 0.2is$ and $\beta 0.3is$)

The signal connector on the cable side for $\beta 0.2is$ and $\beta 0.3is$ is not drip proof. To connect the cable, a dedicated crimping tool must be used. Consider crimping, cable clamp, and voltage drop. Also note that there are restrictions.

| | <i>For Signal</i> | | |
|---|--|------------------------------------|---|
| Housing specification (Tyco Electronics AMP) | 1-1318118-6 (D-2100D 12-position receptacle housing) | | |
| Contact specifications (Tyco Electronics AMP) | 1318107-1 (D-2 receptacle contact M) | | 1318108-1 (D-2 receptacle contact S) |
| Applicable wire size | 0.18 to 0.5 mm ² | 0.3 to 0.85 mm ² | 0.08 to 0.2 mm ² |
| Insulation external diameter | φ0.88 to 1.5 mm | φ1.1 to 1.87 mm | φ0.88 to 1.5 mm |
| Applicable crimping tool | 1463475-1 (Dedicated crimping tool) | 1276654-1 (D-2 M standard tool) | 1276653-1 (D-2 S standard tool) |

The following signal connector kit is available:

| | <i>For signal</i> |
|---|--|
| Connector kit specification (FANUC specification) | A06B-6114-K241 |
| Contents of the connector kit | Receptacle housing (1-1318118-6)×1 Receptacle contact D-2 M (1318107-1)×12 |

The following dedicated tools are required for this connector.

| | <i>Applicable contact</i> | <i>Tyco Electronics AMP specification</i> | <i>FANUC specification</i> |
|---------------|---|---|----------------------------|
| Crimping tool | D-2 contact size M (Dedicated crimping tool for wire size 0.18 to 0.5 mm ²) | 1463475-1 | A06B-6114-K242 |
| | D-2 contact size M | 1276654-1 | A06B-6110-K220#D2M |
| | D-2 contact size S | 1276653-1 | - |
| Extractor | D-2 contact | 1276716-1 | A06B-6110-K220#D2R |

Notes:

- When you use the recommended wire (cable diameter of 0.18 to 0.5 mm) with a D-2 size M contact, the dedicated crimping tool listed above is required. Use a standard crimping tool for a D-2 contact within the applicable range, checking the size of the wire to be used, contact type, and crimping tool specification.
- The contacts are of the type that crimps the covering in addition to the wire. Follow the dimension of the insulation part listed above. An insulation of a diameter outside the above range may be able to be connected depending on the wire or tool, however. For details, contact the connector manufacturer.

24.3 Signal Connectors on the Cable Side (models $\beta 0.4is$ to $\beta 22is$ and $\beta 2HVis$ to $\beta 22HVis$)

The signal connectors on the cable side for $\beta 0.4is$ to $\beta 22is$ are drip proof when engaged with the motor connector. To connect the cable, a dedicated crimping tool must be used. Consider crimping, cable clamp, and voltage drop. Also note that there are restrictions.

| | | <i>For signal</i> | |
|------------------------------|---|---|--|
| Connector specifications | Straight type | JN2DS10SL1 or JN2DS10SL2: Connector, JN1-22-22S: Contact (Japan Aviation Electronics Industry) A06B-6114-K204#S (FANUC specification) * Including the contact | |
| | Elbow type | JN2FS10SL1 or JN2FS10SL2: Connector, JN1-22-22S: Contact (Japan Aviation Electronics Industry) A06B-6114-K204#E (FANUC specification) * Including the contact | |
| Insulation external diameter | | $\phi 1.5$ or less | |
| Compatible cable O.D. | | $\phi 5.7$ to $\phi 7.3$: JN2DS10SL1 or JN2FS10SL1 $\phi 6.5$ to $\phi 8.0$: JN2DS10SL2 or JN2FS10SL2 * With the FANUC specifications, two types of bushings: for $\phi 5.7$ to $\phi 7.3$ and for $\phi 6.5$ to $\phi 8.0$ are included. | |
| Used wire | 5V, 0V | Cable length: 28 m or less $0.3 \text{ mm}^2 \times 2$ | Cable length: 50 m or less $0.5 \text{ mm}^2 \times 2$ (Strand configuration: 20/0.18 or 104/0.08) |
| | 6V | 0.3 mm^2 | 0.5 mm^2 (Strand configuration: 20/0.18 or 104/0.08) |
| | RD, *RD | Twisted pair of at least 0.18 mm^2 | |
| Crimping tool | AWG#22 (0.33 mm^2) to AWG#24 (0.2 mm^2) AWG#26 (0.13 mm^2) to AWG#28 (0.08 mm^2) | | CT150-2-JN1-B (Japan Aviation Electronics Industry) (conventional specification) A06B-6114-K201#JN1S (FANUC specification) |
| | AWG#21(0.5 mm^2) AWG#25(0.18 mm^2) | | CT150-2-JN1-F (Japan Aviation Electronics Industry) (conventional specification) A06B-6114-K201#JN1L (FANUC specification) |
| | AWG#22(0.33 mm^2) to AWG#24(0.2 mm^2) AWG#25(0.18 mm^2) | | CT150-2-JN1-C (Japan Aviation Electronics Industry) (new specification) |
| Extractor | ET-JN1(Japan Aviation Electronics Industry) A06B-6114-K201#JN1R (FANUC specification) | | |

Servo Products Specification Guide

Cable K1 Connectors

The figure below shows the outside dimensions of each type of connector when engaged.

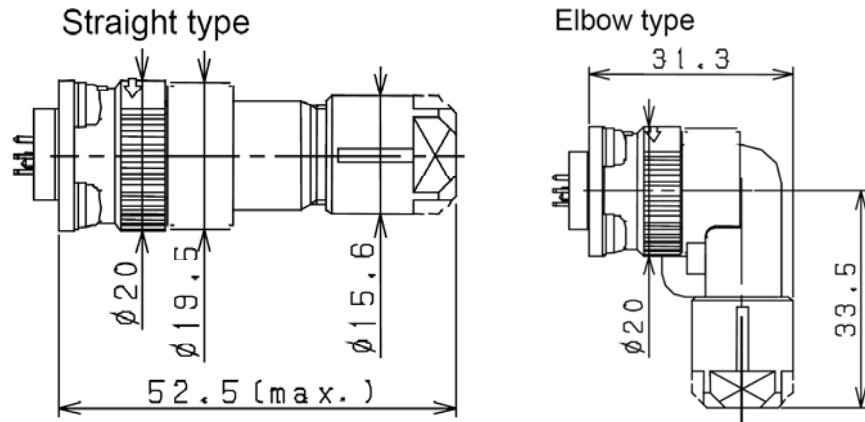

β0.4is to β22is and β2HVis to β22HVis

CAUTION

1. In case that the cable is prepared by MTB, total resistance of 5V and 0V must be less than 2Ω .
2. Encoder side connector can accept maximum 0.5mm^2 (wire construction 20/0.18 or 104/0.08, diameter $\phi 1.5$ or less) wire and sheath diameter is $\phi 5.7$ to $\phi 8.0$. In case of using thicker wire or cable, take measures described below.

[Case 1] Cable conductor exceeds 0.5mm^2 .

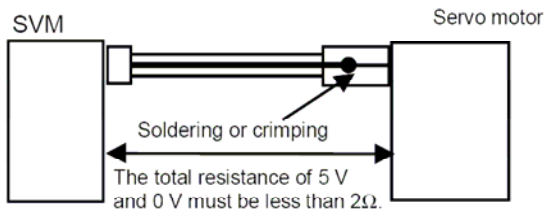

[Case 2] Sheath diameter of exceeds $\phi 8$.

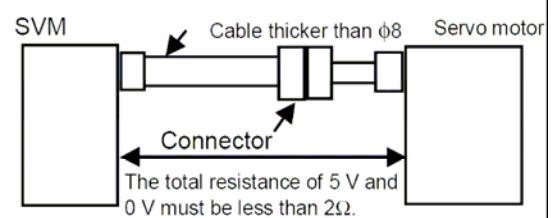

3. If an incremental Encoder is used, it is not necessary to connect 6V.

24.4 Power and Brake Connectors on the Cable Side (models $\beta 0.2is$ and $\beta 0.3is$)

Dedicated connectors which are TÜV approved are available as the connector for power for the $\beta 0.2is$ and $\beta 0.3is$. The following subsection describes the specifications as a connector kit. These connectors are dripproof when engaged. To connect the cable, a dedicated crimping tool must be used. Consider crimping and cable clamp. Also note that there are restrictions.

| | <i>For power and brake</i> |
|---|---|
| Housing specification (Tyco Electronics AMP) | 3-178129-6 (D-3200M 6-position receptacle housing XY) |
| Contact specifications (Tyco Electronics AMP) | 1-175218-2 (D-3 receptacle contact L) |
| Applicable wire size | 0.5 to 1.25 mm ² |
| Insulation external diameter | φ1.8 to 2.8 mm |

The following power and brake connector kit is available:

| | <i>For power and brake</i> |
|--|--|
| Connector kit specifications (FANUC specification) | A06B-6114-K240 |
| Contents of the connector kit | Receptacle housing (3-178129-6) × 1 Receptacle contact D-3 L (1-175218-2) × 6 |

The following dedicated tools are required for this connector.

| | <i>Applicable Contact</i> | <i>Tyco Electronics AMP Specification</i> | <i>FANUC Specification</i> |
|---------------|---------------------------|---|----------------------------|
| Crimping tool | D-3 contact size L | 914596-3 | A06B-6110-K220#D3L |
| Extractor | D-3 contact | 234168-1 | A06B-6110-K220#D3R |

Note: The contacts are of the type which crimps the covering in addition to the wire. Follow the dimension of the insulation part listed above. An insulation of a diameter outside the above range may be able to be connected depending on the wire or tool, however. For details, contact the connector manufacturer.

24.5 Power and Brake Connectors on the Cable Side (models $\beta 0.4is$ to $\beta 1is$)

Dedicated connectors that are TÜV approved are available as the connector for power for the $\beta 0.4is$ to $\beta 1is$. The following subsection describes the specifications as a connector kit. These connectors are drip proof when engaged. To connect the cable, a dedicated crimping tool must be used. Consider crimping and cable clamp. Also note that there are restrictions.

| | | <i>For power</i> | <i>For brake</i> |
|--|---------------|------------------|------------------|
| Connector body specifications (MOLEX JAPAN Co., Ltd.) | Straight type | 54983-0000 | 54982-0000 |
| | Elbow type | 55765-0000 | 55766-0000 |

| | | <i>For power</i> | <i>For brake</i> |
|--|--|---|------------------|
| Contact specifications (MOLEX JAPAN Co., Ltd.) | | 56052-8100 | |
| Applicable wire size | | 0.75 to 1.05 mm ² (AWG18 to AWG17) | |
| Insulation external diameter | | φ2.5 mm or less | |
| Compatible cable O.D. | | φ9.1 to φ9.8 mm | φ6.2 to φ6.7 mm |

The following power and brake connector kit is available:

| | | <i>For power</i> | <i>For brake</i> |
|--|---------------|-----------------------------------|-----------------------------------|
| Connector kit specification (FANUC specification) | Straight type | A06B-6114-K230#S | A06B-6114-K232#S |
| | Elbow type | A06B-6114-K230#E | A06B-6114-K232#E |
| Contents of the connector kit | | Connector body × 1 Contact × 4 | Connector body × 1 Contact × 3 |

The following dedicated tools are required for this connector.

| | <i>MOLEX JAPAN Co., Ltd</i> | <i>FANUC Specification</i> |
|---------------|-----------------------------|----------------------------|
| Crimping tool | 57406-5000 | A06B-6114-K234#C |
| Extractor | 57406-6000 | A06B-6114-K234#R |

Note: The contacts are of the type that crimps the covering in addition to the wire. Follow the dimension of the insulation part listed above. An insulation of a diameter outside the above range may be able to be connected depending on the wire or tool, however. For details, contact the connector manufacturer.

24.6 Power and Brake Connectors on the Cable Side (models β 2is, β 2HVis, β 4is and β 4HVis)

Dedicated connectors that are TÜV approved are available as the connector for power for the β 2is and β 4is. These connectors differ from the conventional α series connectors in connectors and contacts. The following subsection describes the specifications as a connector kit. These connectors are dripproof when engaged. To connect the cable, a dedicated crimping tool must be used. Consider crimping and cable clamp. Also note that there are restrictions.

| | | <i>For power</i> |
|---|-----------------------------------|--|
| Connector kit specifications (Including the contact) | Straight type (standard) | 1473063-2 (Tyco Electronics AMP) A06B-6114-K220#S (FANUC specification) |
| | Elbow type ^(CAUTION 1) | 1473393-2 (Tyco Electronics AMP) A06B-6114-K220#E (FANUC specification) |
| Applicable wire size ^(CAUTION 2) | | AWG#18 to 16 |
| Insulation external diameter ^(CAUTION 3) | | ϕ 1.8 to 2.8 |
| Compatible cable O.D. ^(CAUTION 4) | | ϕ 9.9 to 11.4 |
| Crimping tool ^(CAUTION 5) | | 91579-1 (Tyco Electronics AMP) A06B-6114-K221#C (FANUC specification) |
| Extractor ^(CAUTION 5) | | 1463329-1 (Tyco Electronics AMP) A06B-6114-K221#R (FANUC specification) |

CAUTION

1. For the elbow type, a cable juts from the motor in a vertical direction. To connect a conduit hose to the connector, use the elbow type. (The straight type cannot be used due to dimensional restrictions.)
2. The contact is of the crimp type. Be careful of the applicable wire.
3. The crimping contact crimps the covering in addition to the wire. Follow the dimensions listed above. An insulation of a smaller diameter may be able to be connected by a wire or tool, however. For details, contact Tyco Electronics AMP.
4. To satisfy the TÜV-approved and waterproof performance, a cable of an outside diameter within the applicable cable clamp range of ϕ 9.9 to ϕ 11.4 must be used.
5. Dedicated tools are required for crimping and extracting the contact. Keep them on hand when required.

24.7 Power Connectors on the Cable Side (models $\beta 8is$ to $\beta 22is$ and $\beta 8HVis$ to $\beta 22HVis$)

To meet the IEC60034 standard, TÜV-approved plug connectors and cable clamps should be used in connecting the power cable. To meet the IEC60034 standard by using a cable or conduit hose seal adapter, contact the manufacturer for details. FANUC can provide TÜV approved types (waterproof) and waterproof types as plug connectors on the cable side for the FANUC βis series AC servo motors; all these connectors are black. Of course, conventional plug connectors may be used, because they are MS-compatible. The specifications of each connector are explained based on the examples shown below.

Example of connector connection

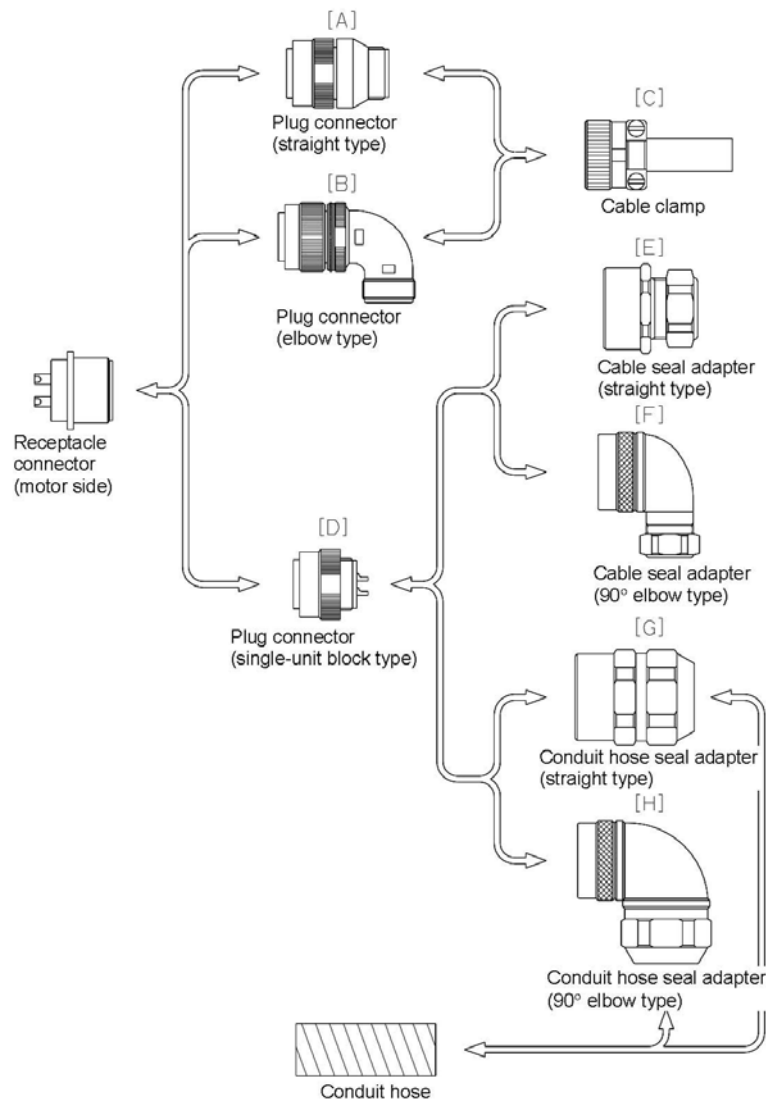

Specifications of plug connectors on the cable side (support for waterproof IP67, TÜV-approved type)

| Model Name | [A] Straight Type Plug Connector | [B] Elbow Type Plug Connector | [C] Cable Clamp | [D] Single Block Type Plug Connector |
|------------------------------------|--|--|---|--|
| For Power | | | | |
| β8is β8HVis β12is β12HVis | H/MS3106A18-10S-D-T (10) (Hirose Electric) | H/MS3108A18-10SD-T (10) (Hirose Electric) | H/MS3057-10A (10) (Hirose Electric) | H/MS3106A18-10SD-T (13) (Hirose Electric) |
| | Solder pot diameter φ2.6 | Solder pot diameter φ2.6 | Compatible cable O.D. φ10.3 to φ14.3 | Solder pot diameter φ2.6 |
| β22is β22HVis | <1> JL04V-6A22-22SE-EB <2> JL04V-6A22-22SE-EB1 (Japan Aviation Electronics Industry) | <1> JL04V-8A22 - 22SE-EB <2> JL04V-8A22 - 22SE-EB1 (Japan Aviation Electronics Industry) | <1> JL04-2022CK (14) <2> JL04-2428CK (20) (Japan Aviation Electronics Industry) | JL04V-6A22-22SE (Japan Aviation Electronics Industry) |
| | Solder pot diameter φ5.3 | Solder pot diameter φ5.3 | Compatible cable O.D. <1> φ12.9 to φ16.0 <2> φ18 to φ21 | Solder pot diameter φ5.3 |

* For the connectors of size 22-22, the part number of the plug connector differs depending on the type of cable clamp.

* The items preceded by the same number in < > correspond to each other.

CAUTION

TÜV have certified that the plug connectors and cable clamps listed above, when combined with the FANUC AC Servo Motor βis series, satisfy the VDE0627 safety standard. Several manufacturers offer other plug connectors. For information about whether the plug connectors satisfy the safety standard when combined with the FANUC αi series, contact the corresponding manufacturer. Also contact the manufacturers if you require details of their products. For details, see Chapter 4, "CONDITIONS FOR APPROVAL RELATED TO THE IEC60034 STANDARD."

- Hirose Electric (HRS): H/MS310 TÜV-conforming series
- Japan Aviation Electronics Industry (JAE): JL04V series
- DDK Ltd. (DDK): CE05 series

The signal connectors and 24V brake connectors are not subject to the IEC60034 standard.

Servo Products Specification Guide

Specifications of plug connectors on the cable side (support for waterproof IP67)

| Model Name | [A] Straight Type Plug Connector | [B] Elbow Type Plug Connector | [C] Cable Clamp | [D] Single Block Type Plug Connector |
|---|--|---|--|---|
| For Power | | | | |
| β 8is β 8HVis β 12is β 12HVi | JA06A-18-10S-J1-EB (Japan Aviation Electronics Industry) H/MS3106A1810S(10) (Hirose Electric) MS3106A18-10S-BBSS (DDK Ltd.) | JA08A-18-10S-J1-EB (Japan Aviation Electronics Industry) H/MS3108B18-10S(10) (Hirose Electric) MS3108A18-10S-BBAS (DDK Ltd.) | JL04-18CK(13) (Japan Aviation Electronics Industry) H/MS3057-10A(10) (Hirose Electric) CE3057-10A-1(D265) (DDK Ltd.) | JA06A-18-10S-J1(A72) (Japan Aviation Electronics Industry) H/MS3106A18-10S(13) (Hirose Electric) MS3106A18-10S-B (D190) (DDK Ltd.) |
| β 22is β 22HVis | JA06A-22-22S-J1-EB (Japan Aviation Electronics Industry) H/MS3106A2222S(10) (Hirose Electric) MS3106A22-22S-BBSS (DDK Ltd.) | JA08A-22-22S-J1-EB (Japan Aviation Electronics Industry) H/MS3108B22-22S(10) (Hirose Electric) MS3108A22-22S-BBAS (DDK Ltd.) | JL04-2022CK-(14) (Japan Aviation Electronics Industry) H/MS3057-12A(10) (Hirose Electric) CE3057-12A-1(D265) (DDK Ltd.) | JA06A-22-22S-J1(A72) (Japan Aviation Electronics Industry) H/MS3106A22-22S(13) Hirose Electric) MS3106A22-22S-B (D190) (DDK Ltd.) |

24.8 Brake Connectors on the Cable Side (models $\beta 8is$ to $\beta 22is$ and $\beta 8HVis$ to $\beta 22HVis$)

The models $\beta 8is$ to $\beta 22is$ use a dedicated connector to connect the built-in brake cable. This connector is dripproof. It is connected by soldering, so no special tool is required. Consider soldering, cable clamp, and voltage drop. Also note that there are restrictions.

Specifications of connectors for brake (models $\beta 8is$ to $\beta 22is$)

| | | For brake |
|---------------------------------------|---------------|--|
| Connector specifications | Straight type | JN2DS04FK2 (Japan Aviation Electronics Industry) A06B-6114-K213#S (FANUC specification) |
| | Elbow type | JN2FS04FK2 (Japan Aviation Electronics Industry) A06B-6114-K213#E (FANUC specification) |
| Applicable wire size | | AWG#16 or less (1.25mm^2 or less) * Solder pot diameter $\phi 1.9$ |
| Insulation external diameter | | $\phi 2.7$ or less |
| Compatible cable O.D. | | $\phi 6.5$ to 8.0 |
| Example of applicable wire | | 300-V two-conductor vinyl heavy-duty power cord cable VCTF (JIS C 3306) or equivalent |
| Applicable wire size and cable length | | 0.75mm^2 (AWG#18) when cable length 30 m or less 1.25mm^2 (AWG#16) when cable length 50 m or less |

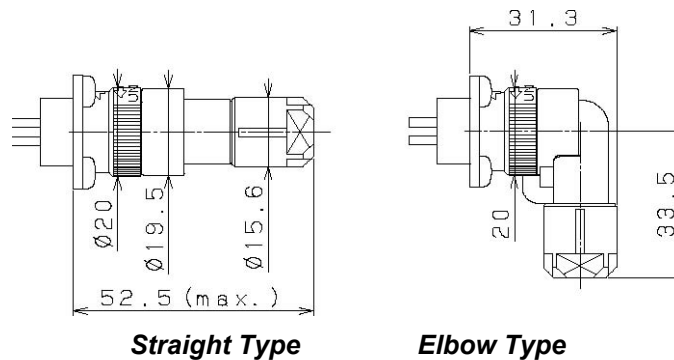

CAUTION

1. The same body is used for the brake and fan connectors. They differ in the key position to prevent an improper insertion.
2. If the cable length is longer than or equal to 50 m, take measures such as installation of repeaters so that the sum of wire resistance (for both ways) becomes 1.5Ω or less.
3. For details of brakes, see Section 18.4

24.9 Connection to a Conduit Hose

This section gives information on the specifications of several adapters to be connected that are made by conduit hose manufacturers for reference purposes. Before using an adapter, contact the corresponding conduit hose manufacturer.

Specifications of plug connectors on the cable side (Waterproof type/seal adapter specifications)

| Model Name | [E] Cable Seal adapter Straight type | [F] Cable Seal adapter Elbow type | [G] Conduit hose Seal adapter Straight type | [H] Conduit hose Seal adapter Elbow type |
|---|---|---|--|--|
| For power | | | | |
| β 2is, β 2HVis β 4is, β 4HVis | | | N2BM20-FN4 (SANKEI) MAS-SG16-M20 (NEOFLEX) | |
| β 8is, β 8HVis β 12is, β 12HVis | CKD12-18 (SANKEI) YSO 18-12-14 (DAIWA DENGYOU) ACS-12RL-MS18F (NIPPON FLEX) CG12S-JL18 (NEOFLEX) | C90° KD12-18 (SANKEI) YLO 18-12-14 (DAIWA DENGYOU) ACA-12RL-MS18F (NIPPON FLEX) CG12A-JL18 (NEOFLEX) | KKD16-18 (SANKEI) MSA 16-18 (DAIWA DENGYOU) RCC-104RL-MS18F (NIPPON FLEX) MAS16S-JL18 (NEOFLEX) | K90° KD16-18 (SANKEI) MAA 16-18 (DAIWA DENGYOU) RCC-304RL-MS18F (NIPPON FLEX) MAS16A-JL18 (NEOFLEX) |
| β 22is, β 22HVis | CKD16-22 (SANKEI) YSO 22-12-14 (DAIWA DENGYOU) ACS-16RL-MS22F (NIPPON FLEX) CG16S-JL22 (NEOFLEX) | C90° KD16-22 (SANKEI) YLO 22-12-14 (DAIWA DENGYOU) ACA-16RL-MS22F (NIPPON FLEX) CG16A-JL22 (NEOFLEX) | KKD22-22 (SANKEI) MSA 22-22 (DAIWA DENGYOU) RCC-106RL-MS22F (NIPPON FLEX) MAS22S-JL22 (NEOFLEX) | K90° KD22-22 (SANKEI) MAA 22-22 (DAIWA DENGYOU) RCC-306RL-MS22F (NIPPON FLEX) MAS22A-JL22 (NEOFLEX) |
| For signal | | | | |
| Common to all models (other than β 0.2is and β 0.3is) | | | N2KY16-FN3 (SANKEI) PCJN-12-M13F (DAIWA DENGYOU) RQJN-M13-9 RQJN-M13-16 (NEOFLEX) | |
| For brake | | | | |
| Common to all models (other than β 0.2is and β 0.3is) | | | N2KY16-FN3 (SANKEI) PCJN-12-M13F (DAIWA DENGYOU) RQJN-M13-9 RQJN-M13-16 (NEOFLEX) | |

(*) Manufacturers: SANKEI: SANKEI MANUFACTURING CO., LTD.
DAIWA DENGYOU: DAIWA DENGYOU CO., LTD.
NIPPON FLEX: NIPPON FLEX CO., LTD.
NEOFLEX

24.10 System Connection Diagram and Cable Reference

Motor and amplifier connector kits required for the system are available from GE Fanuc. The following figures indicate the physical connector locations on the amplifiers, the appropriate connector designations and connector kit part numbers. The following diagrams illustrate typical system interconnections. For details on cables and connectors, refer to Table III-33.

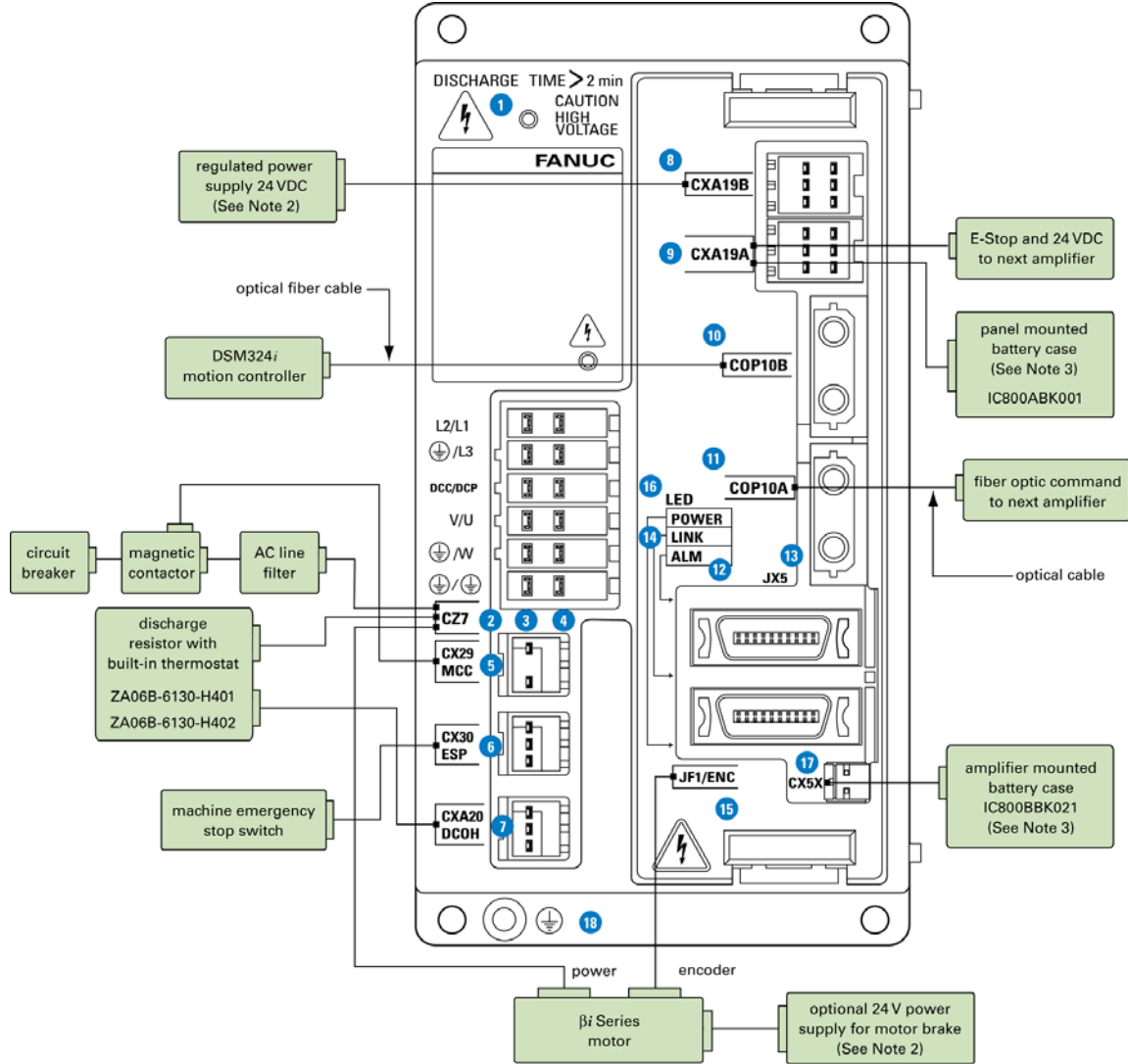

Connector Location

| No. | Name | Description | No. | Name | Description | No. | Name | Description |
|-----|-------|---|-----|--------|--|-----|-------|---|
| 1 | | DC link charge LED | 7 | CXA20 | Regenerative resistor overtemperature switch connector | 13 | JX5 | Reserved |
| 2 | CZ7-1 | Main power input connector | 8 | CXA19B | 24 VDC power input | 14 | LINK | Fiber optic link status LED |
| 3 | CZ7-2 | Discharge resistor connector | 9 | CXA19A | 24 VDC power input | 15 | JF1 | Serial encoder feedback |
| 4 | CZ7-3 | Motor power connector | 10 | COP10B | Fiber optic servo command input | 16 | POWER | Control power status display LED |
| 5 | CX29 | Connector for main power MCC control signal | 11 | COP10A | Fiber optic servo command output | 17 | CX5X | Absolute encoder battery |
| 6 | CX30 | E-stop signal connector | 12 | ALM | Servo alarm status LED | 18 | | Tapped hole for grounding the amplifier |

Notes

- 1: Always install the circuit breakers, magnetic contactor, and AC line filter.
2. User a regulated 24 VDC power supply for the amplifier. The 24 VDC power supply for the amplifier and power supply for the motor brake cannot be shared.
3. The IC800ABK001 encoder battery pack mounts separately on the panel and can power up to four axes. Alternatively, the IC800BBK021 one-axis lithium battery can be snapped onto each amplifier.

Servo Products Specification Guide

Figure III-25. β SVM1- 20i Connection Diagram

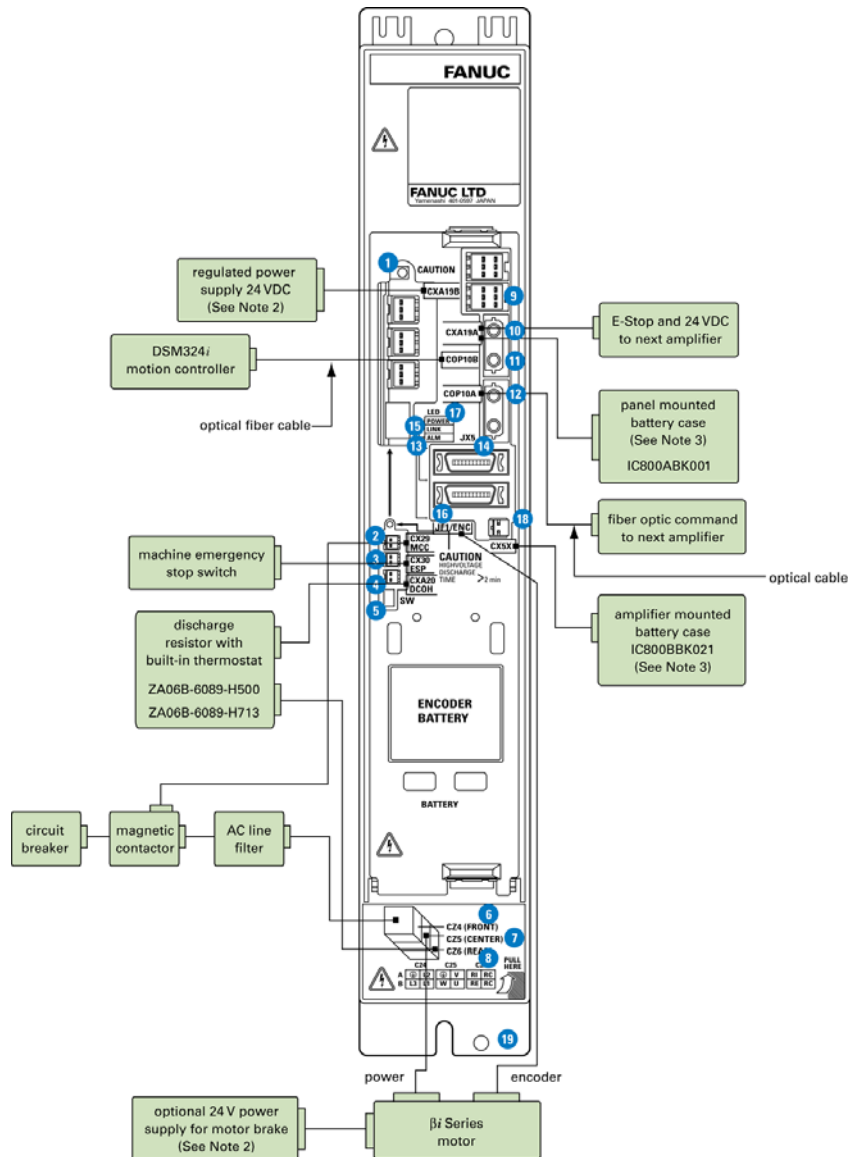



Figure III-26. β SVM1- 40i, β SVM1-10HVi and β SVM1-20HVi Connection Diagram

Servo Products Specification Guide

Table III-32. Connector Location

| No. | Name | Description | No. | Name | Description | No. | Name | Description |
|-----|-------|---|-----|--------|----------------------------------|-----|---|---|
| 1 | | DC link charge LED | 7 | CZ5 | Main power connector | 13 | ALM | Servo alarm status LED |
| 2 | CX29 | Main power input connector MCC control signal | 8 | CZ6 | Discharge resistor connector | 14 | JX5 | Reserved |
| 3 | CX30 | E-stop signal connector | 9 | CXA19B | 24 VDC power input | 15 | LINK | Fiber optic link status LED |
| 4 | CXA20 | Regenerative resistor overtemperature switch connector | 10 | CXA19A | 24 VDC power input | 16 | JF1 | Serial encoder feedback |
| 5 | SW | Setting switch (DC alarm level) | 11 | COP10B | Fiber optic servo command input | 17 | POWER | Control power status display LED |
| 6 | CZ4 | Main power input connector | 12 | COP10A | Fiber optic servo command output | 18 | CX5X | Absolute encoder batter |
| | | | | | | 19 |  | Tapped hole for grounding the amplifier |

Notes

- 1: Always install the circuit breakers, magnetic contactor, and AC line filter.
2. User a regulated 24 VDC power supply for the amplifier. The 24 VDC power supply for the amplifier and power supply for the motor brake cannot be shared.
3. The IC800ABK001 encoder battery pack mounts separately on the panel and can power up to four axes. Alternatively, the IC800BBK021 one-axis lithium battery can be snapped onto each amplifier.

Table III-33. System Connection Cables Summary

| Ref. | Connects | GE Fanuc Cable Part Number | When Required |
|------|--|---|---|
| K1 | Built in Serial Motor Encoder to Amplifier (JF1) | See Tables 71HIII-23 and 72HIII-24. | Always. |
| K2 | AC Power to Amplifier | Customer Supplied | Always. |
| K3 | Motor Power to Amplifier | See Tables 71HIII-23 and 72HIII-24. | Always. |
| K4 | Amplifier to Regenerative Discharge Unit | N/A (included with regenerative discharge unit) | In some cases. ¹ |
| K5 | Regenerative Discharge Unit Over Temperature Switch to Amplifier | N/A (included with regenerative discharge unit) | In some cases. ¹ (When an external regenerative discharge resistor is not used, a jumper connection must be installed.) |
| K5 | Servo Amplifier Emergency Stop Input (CX30) to Machine E-Stop Contact | Customer Supplied | Always. |
| K6 | Connection of Daisy Chain to an adjacent amplifier the 24 VDC, E-stop and encoder battery backup signals | Customer Supplied | Always. |
| K7 | Relay Output to Control the Main AC Power Contactor Coil (MCC) | Customer Supplied | Control-dependent. Consult your control documentation. |
| K8 | Servo Amplifier Emergency Stop Input (CX30) to Machine E-Stop Contact | Customer Supplied | Always. (When an E-Stop switch is not used a jumper connection must be installed.) |
| K9 | Amplifier (CX19B) to Panel Mounted Backup Battery Holder IC800ABK001 | Customer Supplied | One cable per four amplifiers when IC800APK001 encoder battery backup option is used. |
| K10 | External cooling fan to 24VDC power. | This is a factory-installed jumper (T892), since the fan is not required. | Always. (An alarm will be generated if the jumper is not installed.) |

¹ See “Discharging Regenerative Energy” on page III-42.

24.11 Cable Details

FSSB Fiber Optic Servo Command Interface Cable

The optical cable is available in various lengths and is used to interface up to four amplifiers to the DSM324i motion controller. Additionally the fiber optic cables come in two styles.

| Cable Type | Length* | Part Number |
|--|----------------|------------------------|
| PVC Covered Fiber Optic Cable (use in sealed cabinet only) | 0.15 meter | ZA66L-6001-0023#L150R0 |
| | 0.30 meter | ZA66L-6001-0023#L300R0 |
| | 1 meter | ZA66L-6001-0023#L1R003 |
| | 3 meter | ZA66L-6001-0023#L3R003 |
| Sheathed Fiber Optic Cable* | 1 meter | ZA66L-6001-0026#L1R003 |
| | 3 meter | ZA66L-6001-0026#L3R003 |
| | 5 meter | ZA66L-6001-0026#L5R003 |
| | 10 meter | ZA66L-6001-0026#L10R03 |
| | 20 meter | ZA66L-6001-0026#L20R03 |
| | 30 meter | ZA66L-6001-0026#L30R03 |
| | 50 meter | ZA66L-6001-0026#L50R03 |

*Longer lengths are available but are not stocked.

| |
|----------------|
| WARNING |
|----------------|

GE Fanuc cannot guarantee the servo performance and reliability unless the fiber optic command interface cable meets or exceeds the stated specifications.

FSSB Cable Specifications

Connector maker: Tyco Electronics AMP. Parts list:

| Connector Part | Vendor Part Number |
|-----------------------|---------------------------|
| Ferrule | 316892 |
| Housing | 316890 |
| Stopper | 316891 |
| Spring | 900357 |

- Cable material must be Multi-mode
- Cable loss (max.): 3dB
- The transmission rate is 25Mbps
- The actual fiber used is plastic clad silica fiber
- The core diameter is 200 micrometer, and the plastic clad diameter is 230 micrometer
- The initial loss is 0.015dB per meter (At room temperature)
- The type of light is LED. The wavelength of light is 650nm
- Bend radius minimum: 50mm; Life: ~10 million cycles at 100mm radius, @ +/- 90 degrees
- Twist angle maximum: 360 degrees; Life: 900,000 cycles @ +/- 180 degrees twisting
- Cable must be clamped so that no stretching force is applied and no forces within 200mm (8 inches) of connector.

Servo Products Specification Guide

FSSB Cable Connections

Each β i and β HVi Series amplifier has two FSSB connectors labeled C0P10A and C0P10B. Connector C0P10A is an optical transmitter and C0P10B is an optical receiver. Proper system operation requires that the FSSB cables be installed on the proper connector as shown below.

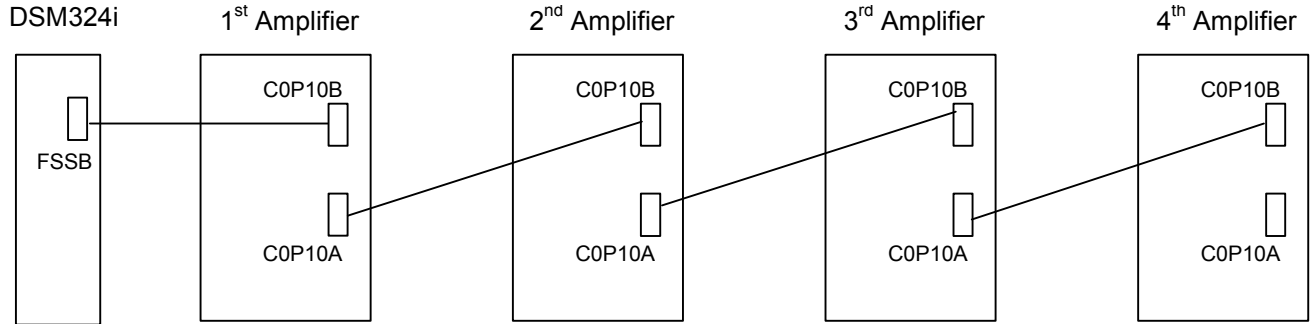

Details of Cable K1- Motor Serial Encoder Feedback

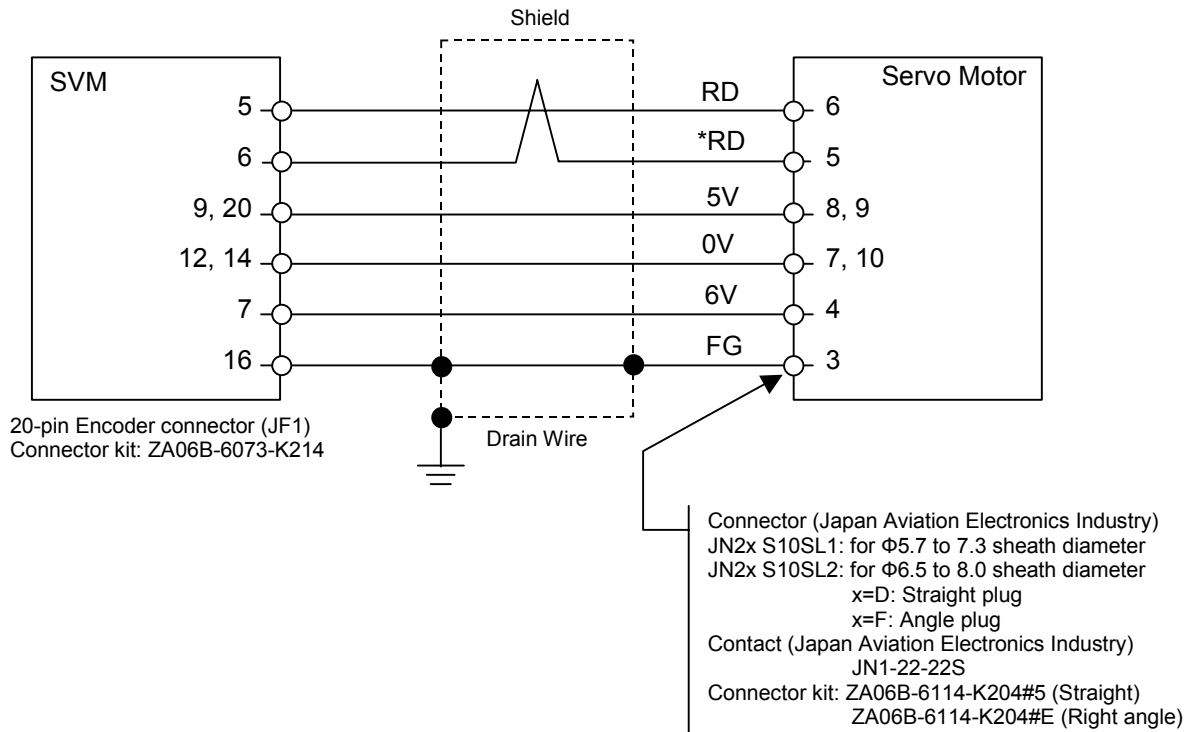

Cable K1 Connectors

The figure below shows the outside dimensions of each type of connector when engaged.

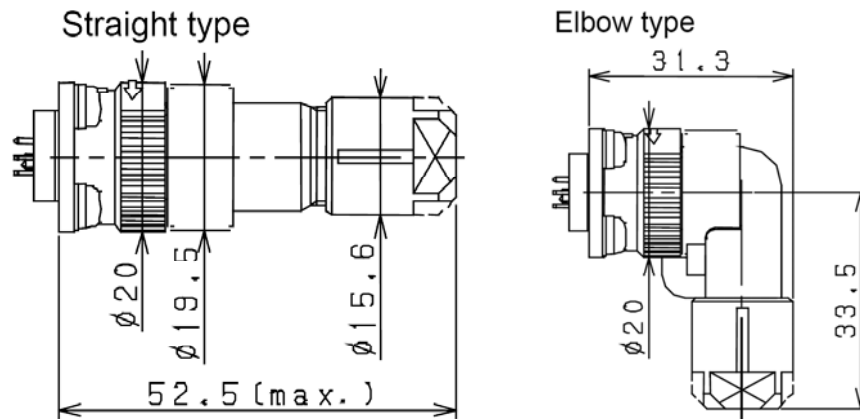

$\beta 0.4is$ to $\beta 22is$ and $\beta 2HVis$ to $\beta 22HVis$

Servo Products Specification Guide

Recommended Cable Conductors

| <i>Signal</i> | <i>Cable Length</i> | |
|---------------|--|---|
| | <i>28m or Less</i> | <i>50m or Less</i> |
| 5V, 0V, 6V | 0.3mm ² x 5 Wire construction 12/0.18 or 60/0.08 Insulation outer diameter Φ1.5 or less | 0.5mm ² x 5 Wire construction 20/0.18 or 104/0.08 Insulation outer diameter Φ1.5 or less |
| RD, *RD | 0.18mm ² or more Twisted pair wire | 0.18mm ² or more Twisted pair wire |
| Drain wire | 0.15 mm ² or more | 0.15 mm ² or more |

Notes:

1. The grounding bar to which the feedback cable shield is connected must be placed as close as possible to the amplifier.
2. Total resistance of the 5V and 0V wire path must be less than 2Ω.
3. Motor encoder connector can accept maximum 0.5mm² wire size (wire construction 20/0.18 or 104/0.08, insulation outer diameter Φ1.5 or less) wire and sheath diameter is Φ 5.7 to Φ 8.0.

Servo Products Specification Guide

Details of Cable K2 – AC Power to β SVM1-20i Amplifier

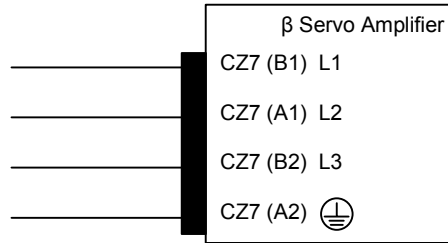

Receptacle Housing

Use the following receptacle housing.

| Manufacturer Model Number | Key Specification | Manufacturer |
|---------------------------|---------------------------------|----------------------|
| 175363-3 | Incorrect-insertion prevent key | Tyco Electronics AMP |

Receptacle Contact

| Receptacle Contact Model Number | Conductor Size | Insulation Outer Diameter (mm) | Manual Tool Model Number | Manufacturer |
|---------------------------------|--|--------------------------------|--------------------------|----------------------|
| L size 1-75218-2 | 0.5—1.25 mm ² 20/18/16 AWG | 1.8—2.8 | 91558-1 | Tyco Electronics AMP |

Connector and Tool Ordering Information

Connectors (including housings and contacts) and tools can be purchased directly from Tyco Electronics AMP. Connectors can also be ordered as options from GE Fanuc as listed below.

| GE Fanuc Ordering Number | Description |
|--------------------------|--|
| ZA06B-6130-K200 | Housing: Incorrect-insertion prevention key 175636-3 (Qty. 1) Incorrect-insertion prevention key 1318095-2 (Qty. 1) Contact: L size, 1-175218-2 (Qty. 10) Applicable wire diameter: 0.5—1.25mm ² , AWG 20/18/16 Applicable tool: 91558-1 (not included in this kit) |
| | <p>Connector pin location as viewed from the (back) wire insertion side.</p> |

Servo Products Specification Guide

Details of Cable K2 – AC Power to β SVM1-40i Amplifier, β SVM1-10HVi and β SVM1-20HVi

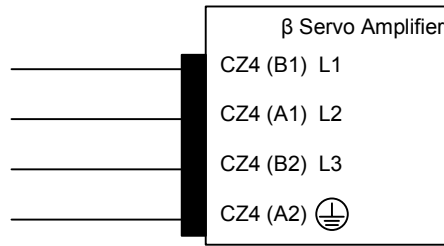

Receptacle Housing

Use the following receptacle housing.

| <i>Manufacturer Model Number</i> | <i>Key Specification</i> | <i>Manufacturer</i> |
|----------------------------------|--------------------------|----------------------|
| 1-917807-2 | XX | Tyco Electronics AMP |

Receptacle Contact

| <i>Receptacle Contact Model Number</i> | | <i>Conductor Size</i> | <i>Insulation Outer Diameter (mm)</i> | <i>Manual Tool Model Number</i> | <i>Manufacturer</i> |
|--|----------|--|---------------------------------------|---------------------------------|----------------------|
| S size | 316040-6 | 1.25—2.20 mm ² 16/14 AWG | 3.0—3.8 | 234170-1 | Tyco Electronics AMP |

Connector and Tool Ordering Information

Connectors (including housings and contacts) and tools can be purchased directly from Tyco Electronics AMP. Connectors can also be ordered as options from GE Fanuc as listed below.

| <i>GE Fanuc Ordering Number</i> | <i>Description</i> | | | | |
|---------------------------------|--|----|----|----|----|
| ZA06B-6110-K200#XXS | <p>Housing: XX key 917807-2 (Qty. 1) Contact: S size, 316040-6 (Qty. 4) Applicable wire diameter: 1.25—2.20mm², AWG 16/14 Applicable tool: 234170-1 (not included in this kit)</p> <p style="text-align: center;">CZ4</p> <table border="1" style="margin-left: auto; margin-right: auto;"> <tr> <td>A2</td> <td>A1</td> </tr> <tr> <td>B2</td> <td>B1</td> </tr> </table> <p>Connector pin location as viewed from the (back) wire insertion side.</p> | A2 | A1 | B2 | B1 |
| A2 | A1 | | | | |
| B2 | B1 | | | | |

Servo Products Specification Guide

Details of Cable K3 – Motor Power to β SVM1-20i Amplifier

The D-3000 and D-5000 connector series manufactured by Tyco Electronic AMP are used for motor power connections to the β i series amplifiers.

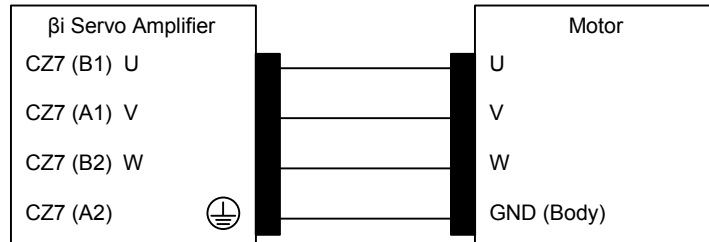

Receptacle Housing

Use the following receptacle housing.

| Manufacturer Model Number | Manufacturer |
|---------------------------|----------------------|
| 1318095-2 | Tyco Electronics AMP |

Receptacle Contact

| Receptacle Contact Model Number | Conductor Size | Insulation Outer Diameter | Manual Tool Model Number | Manufacturer | |
|---------------------------------|----------------|--|--------------------------|--------------|----------------------|
| L size | 1-75218-2 | 0.5—1.25 mm ² 20/18/16 AWG | 1.8—2.8 | 91558-1 | Tyco Electronics AMP |

Connector and Tool Ordering Information

Connectors (including housings and contacts) and tools can be purchased directly from Tyco Electronics AMP. Connectors can also be ordered as options from GE Fanuc as listed below.

| GE Fanuc Ordering Number | Description | | | | | | |
|--------------------------|---|---|---|---|---|---|---|
| ZA06B-6130-K200 | <p>Housing: Incorrect insertion prevent key 175363-3 (Qty. 1) Incorrect insertion prevent key 1318095-2 (Qty. 1)</p> <p>Contact: L size, 1-175218-2 (Qty. 10)</p> <p>Applicable wire diameter: 0.5—1.25mm², AWG 20/18/16</p> <p>Applicable tool: 91558-1 (not included in this kit)</p> <p style="text-align: center;">CZ7</p> <table border="1" style="margin-left: auto; margin-right: auto;"> <tr> <td>U</td> <td>W</td> <td>G</td> </tr> <tr> <td>V</td> <td>G</td> <td>G</td> </tr> </table> <p style="text-align: right;">Connector pin location as viewed from the (back) wire insertion side.</p> | U | W | G | V | G | G |
| U | W | G | | | | | |
| V | G | G | | | | | |

Servo Products Specification Guide

Details of Cable K3 – Motor Power to β SVM1-40i, β SVM1-10HVi and β SVM1-20HVi Amplifier

The D-3000 and D-5000 connector series manufactured by Tyco Electronic AMP are used for motor power connections to the β i series amplifiers.

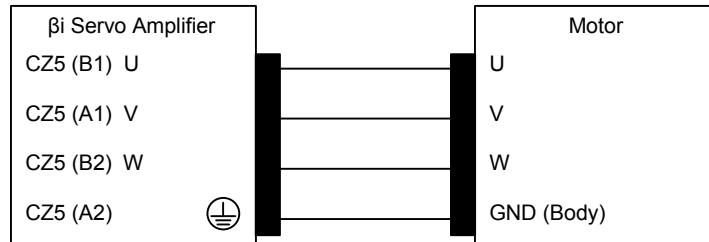

Receptacle Housing

Use the following receptacle housing.

| Manufacturer Model Number | Key Specification | Manufacturer |
|---------------------------|-------------------|----------------------|
| 2-917807-2 | YY | Tyco Electronics AMP |

Receptacle Contact

| Receptacle Contact Model Number | Conductor Size | Insulation Outer Diameter | Manual Tool Model Number | Manufacturer |
|---------------------------------|---------------------------------------|---------------------------|--------------------------|----------------------|
| S size 316040-6 | 1.25—2.2 mm ² 16/14 AWG | 3.0—3.8 | 234170-1 | Tyco Electronics AMP |

Connector and Tool Ordering Information

Connectors (including housings and contacts) and tools can be purchased directly from Tyco Electronics AMP. Connectors can also be ordered as options from GE Fanuc as listed below.

| GE Fanuc Ordering Number | Description | | | | |
|--------------------------|---|---|---|---|---|
| ZA06B-6110-K202#YYS | Housing: YY key 2-917807-2 (Qty. 1) Contact: S size 316040-6 (Qty. 4) Applicable wire diameter: 1.25—2.20mm ² , AWG 16/14 Applicable tool: 234170-1 (not included in this kit) | | | | |
| | <p>CZ5</p> <table border="1"> <tbody> <tr> <td>G</td> <td>V</td> </tr> <tr> <td>W</td> <td>U</td> </tr> </tbody> </table> <p>Connector pin location as viewed from the (back) wire insertion side.</p> | G | V | W | U |
| G | V | | | | |
| W | U | | | | |

Details of Cables K4 and K5 – Regenerative Discharge Resistor

β SVM1-20i

When a Regenerative Discharge Resistor is Used

The following regenerative discharge resistor models are available for the β SVM1-20i amplifier. The housing and contact are connected to the resistor.

- | | |
|------------------------|--------------------|
| ZA06B-6130-H401 | 30 ohms, 20 watts |
| ZA06B-6130-H402 | 30 ohms, 100 watts |

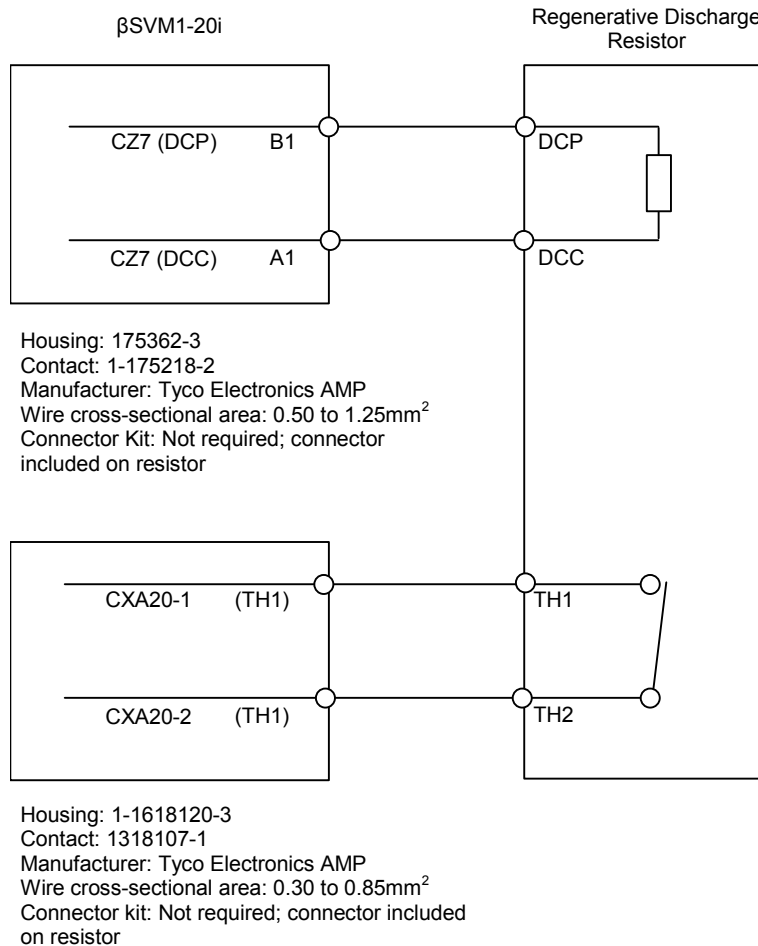

Servo Products Specification Guide

When no Regenerative Discharge Resistor is Used

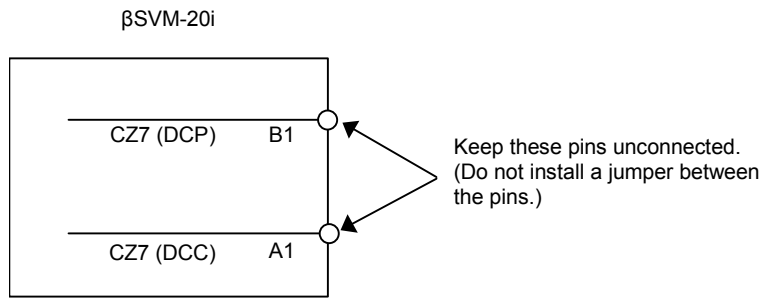

Housing: 175362-3
Contact: 1-175218-2
Manufacturer: Tyco Electronics AMP
Wire cross-sectional area: 0.50 to 1.25mm²
Connector Kit: ZA06B-6130-K200

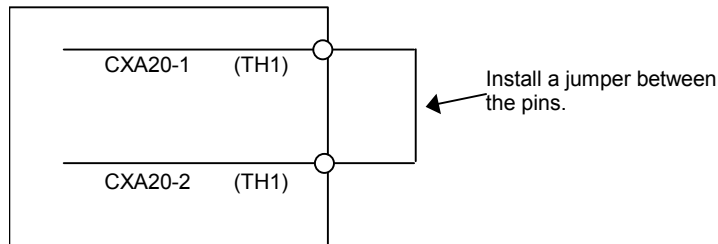

Housing: 1-1318120-3
Contact: 1318107-1
Manufacturer: Tyco Electronics AMP
Wire cross-sectional area: 0.30 to 0.85mm²
Connector Kit: ZA06B-6130-K202

Caution

Do not connect the DCP and DCC pins to each other.

Servo Products Specification Guide

βSVM1-40i

When a Separate Regenerative Discharge Resistor is Used

The following regenerative discharge resistor models are available for the βSVM1-40i amplifier. The users must manufacture the connecting cables.

ZA06B-6089-H500 16 ohms, 200 watts

ZA06B-6089-H713 16 ohms, 200 watts

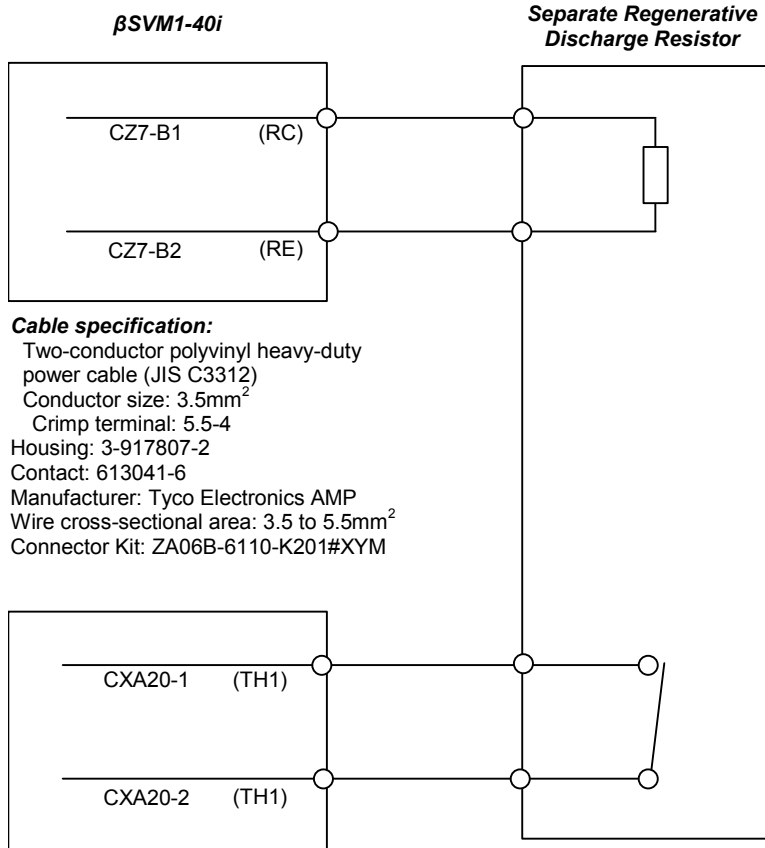

Cable specification:
 Two-conductor polyvinyl heavy-duty power cable (JIS C3312)
 Conductor size: 3.5mm²
 Crimp terminal: 5.5-4
 Housing: 3-917807-2
 Contact: 613041-6
 Manufacturer: Tyco Electronics AMP
 Wire cross-sectional area: 3.5 to 5.5mm²
 Connector Kit: ZA06B-6110-K201#XYM

Cable specification:
 Two-conductor polyvinyl heavy-duty power cable (JIS C3312)
 Conductor size: 0.75mm²
 Crimp terminal: 1.25-4
 Housing: 1-1318120-3
 Contact: 1318107-1
 Manufacturer: Tyco Electronics AMP
 Wire cross-sectional area: 0.3 to 0.85mm²
 Connector Kit: ZA06B-6130-K202

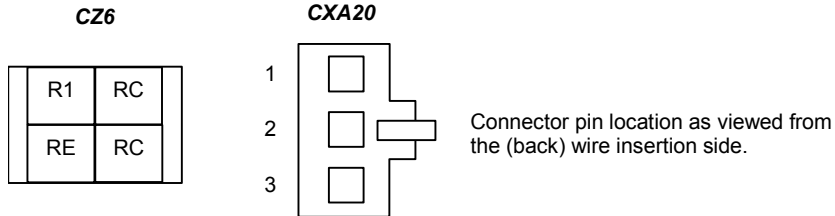

Servo Products Specification Guide

When a Built-in Regenerative Discharge Resistor is Used

βSVM1-40i

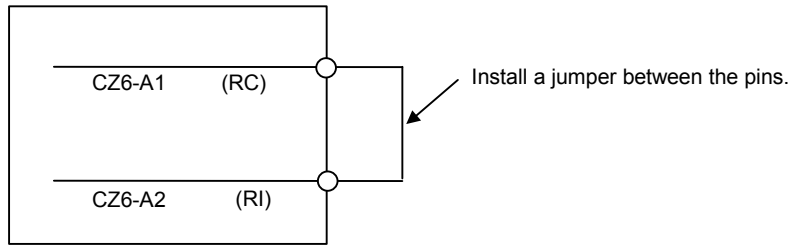

Cable specification:

Two-conductor polyvinyl heavy-duty power cable (JIS C3312)

Conductor size: 3.5mm²

Crimp terminal: 5.5-4

Housing: 3-917807-2

Contact: 613041-6

Manufacturer: Tyco Electronics AMP

Wire cross-sectional area: 3.5 to 5.5mm²

Connector Kit: ZA06B-6110-K201#XYM

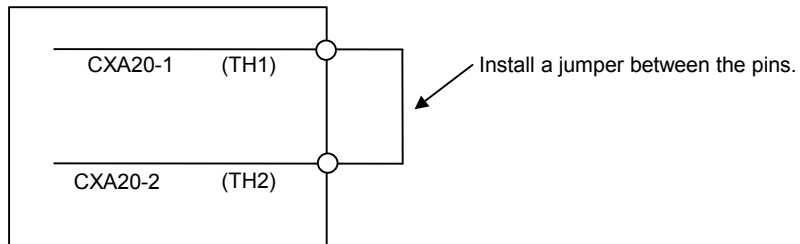

Cable specification:

Two-conductor polyvinyl heavy-duty power cable (JIS C3312)

Conductor size: 0.75mm²

Crimp terminal: 1.25-4

Housing: 1-1318120-3

Contact: 1318107-1

Manufacturer: Tyco Electronics AMP

Wire cross-sectional area: 0.3 to 0.85mm²

Connector Kit: ZA06B-6130-K202

Servo Products Specification Guide

βSVM1-10HVi and βSVM1-20HVi

The βSVM1-10HVi and βSVM1-20HVi amplifiers always use the built-in regenerative discharge resistor and should be wired as follows:

βSVM1-10HVi

βSVM1-20HVi

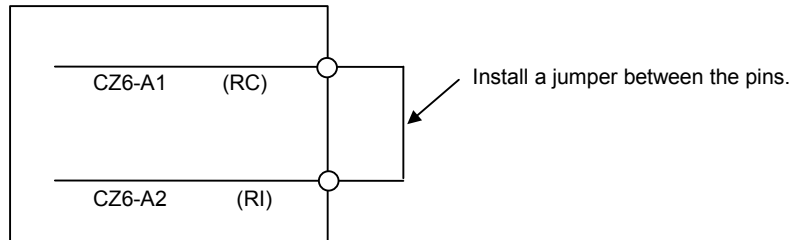

Cable specification:

Two-conductor polyvinyl heavy-duty power cable (JIS C3312)

Conductor size: 3.5mm²

Crimp terminal: 5.5-4

Housing: 3-917807-2

Contact: 613041-6

Manufacturer: Tyco Electronics AMP

Wire cross-sectional area: 3.5 to 5.5mm²

Connector Kit: ZA06B-6110-K201#XYM

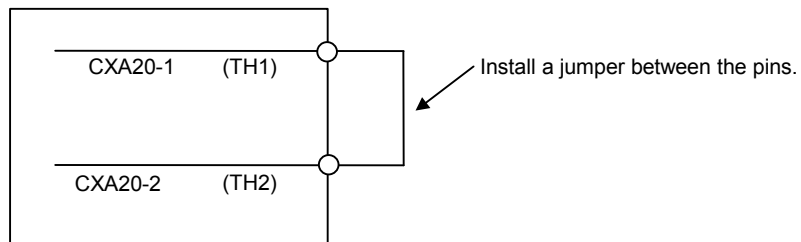

Cable specification:

Two-conductor polyvinyl heavy-duty power cable (JIS C3312)

Conductor size: 0.75mm²

Crimp terminal: 1.25-4

Housing: 1-1318120-3

Contact: 1318107-1

Manufacturer: Tyco Electronics AMP

Wire cross-sectional area: 0.3 to 0.85mm²

Connector Kit: ZA06B-6130-K202

Details of Cable K6 – 24V, E-Stop and Battery Daisy Chain for Multi-Axis Systems

For multi-axis systems, the 24VDC control power, emergency stop, and absolute encoder backup battery signals can be daisy chained from the first amplifier to up to four adjacent amplifiers using the CXA19 connections. The state of the E-stop input signal on connector CX30 on the first amplifier is passed to the other connected amplifiers, allowing an emergency stop condition to be executed on all amplifiers simultaneously. When using this connection for the encoder battery backup, the IC800ABK001 multi-axis battery kit must be connected to the first amplifier. Do not use the IC800BBK021 single-axis battery kit.

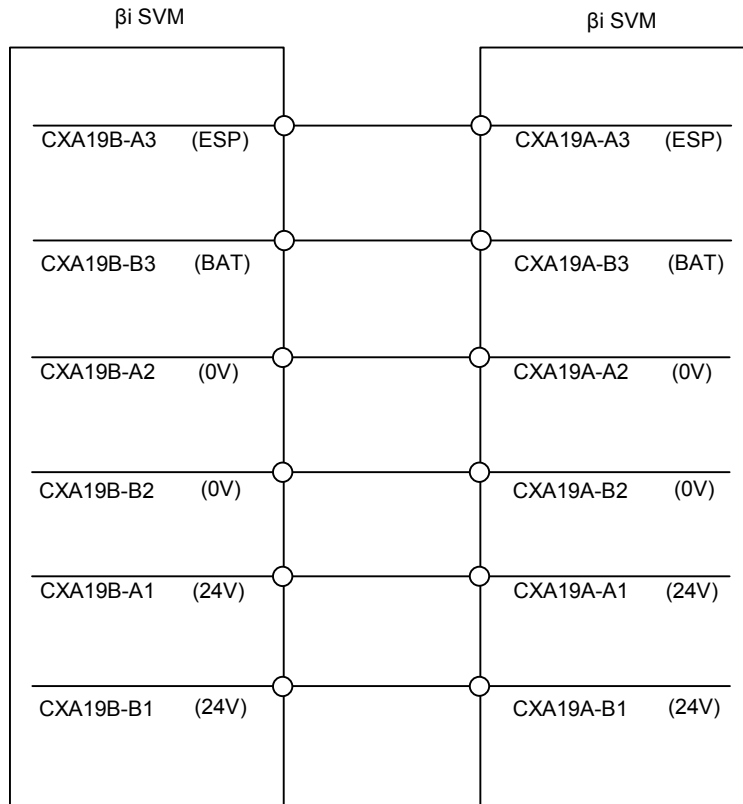

Housing: 1-1318119-3
 Contact: 1318107-1
 Manufacturer: Tyco Electronics AMP
 Wire cross-sectional area: 0.3 to 0.85mm²
 Connector Kit: ZA06B-6130-K201

Housing: 1-1318119-3
 Contact: 1318107-1
 Manufacturer: Tyco Electronics AMP
 Wire cross-sectional area: 0.3 to 0.85mm²
 Connector Kit: ZA06B-6130-K201

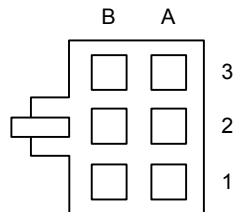

CXA19 connector pin location as viewed from the (back) wire insertion side.

Details of Cable K7 – E-Stop/Power Enable (MCC)

This cable is used to connect the normally open relay contacts on connector CX29 to the power source of the magnetic contactor coil used to interrupt AC power to the amplifier when an amplifier fault occurs or E-stop condition occurs.

The relay contact will close when the amplifier is enabled by the DSM324i controller (MCON signal sent) as long as there are no active servo alarms and the E-stop input on connector CX30 is closed. The relay contacts will open when any one or more of the following conditions occurs:

1. 24 VDC power is removed from the amplifier.
2. A servo alarm occurs on the amplifier.
3. The emergency stop input (CX30) to the amplifier is opened.
4. DSM324i enable (MCON) is 0.

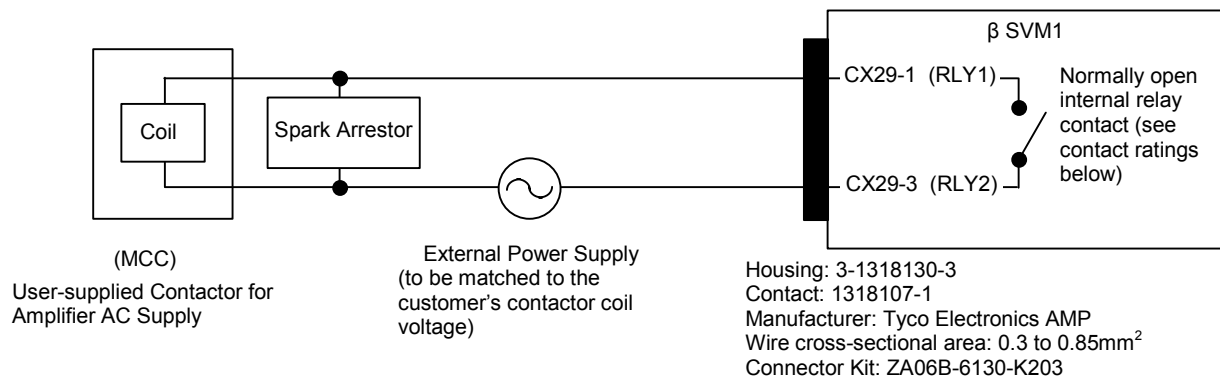

Contact Ratings

| Specification of Internal Contact | Resistor Load ($\cos\phi=1$) | Inductance Load ($\cos\phi=0.4, L/R=7msec$) |
|-----------------------------------|--------------------------------|---|
| Rated load | 250 VAC, 5A 30 VDC, 5A | 250 VAC, 2A 30 VDC, 2A |
| Max. current | 5A | 5A |

CX29 (MCC)

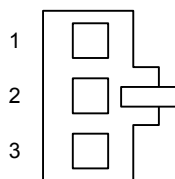

Connector pin location as viewed from (back) wire insertion side

Details of Cable K8 – Servo Amplifier Emergency Stop Connection

The state of this signal input (ESP) is reflected on the CXA19 connector pin A3, allowing one E-stop input to be used for all amplifiers in a multi-axis system (see cable K6). When the E-stop input is open, the MCC relay contacts on connector CX29 will open.

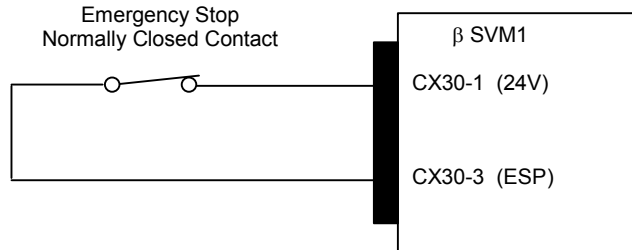

Housing: 3-1318120-3
Contact: 1318107-1
Manufacturer: Tyco Electronics AMP
Wire cross-sectional area: 0.3 to 0.85mm²
Connector Kit: ZA06B-6130-K204

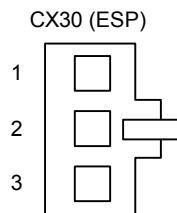

Connector pin location as viewed from the (back) wire insertion side

Details of Cable K9 – Optional External Absolute Encoder Battery Connection

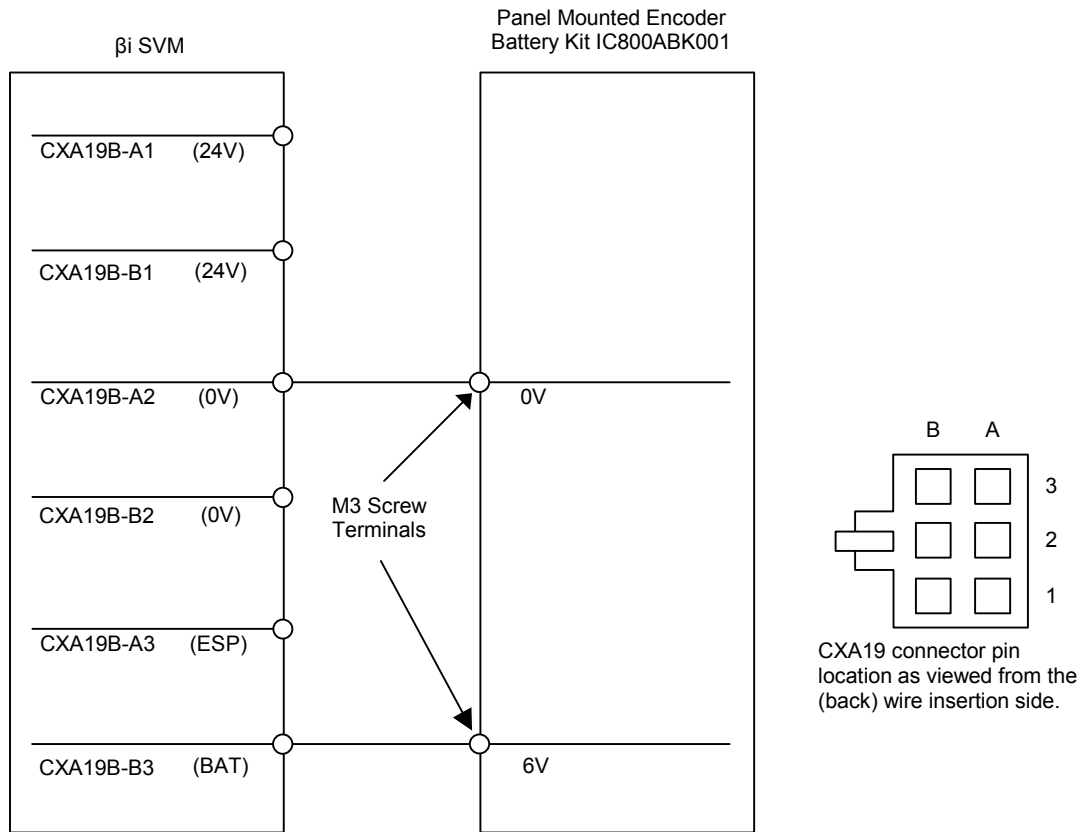

Housing: 1-1318119-3
 Contact: 1318107-1
 Manufacturer: Tyco Electronics AMP
 Wire cross-sectional area: 0.3 to 0.85mm²
 Connector Kit: ZA06B-3160-K201

Crimp terminal: 1.25-2
 Wire cross-sectional area: 0.3 to 0.85mm²

Details of Cable K10 –External Cooling Fan Connector

The β i Series amplifiers include a 3-pin connector on the top of the amplifier for connection to an external cooling fan. No motor/amplifier combination offered by GE Fanuc requires the use of this optional fan. However, the fan connector and associated jumper wire must be installed or an alarm will be generated. The amplifier is shipped with this jumper/connector (T892) installed. Replacement connector: ZA06B-6130-K202 (wire jumper must be installed by user).

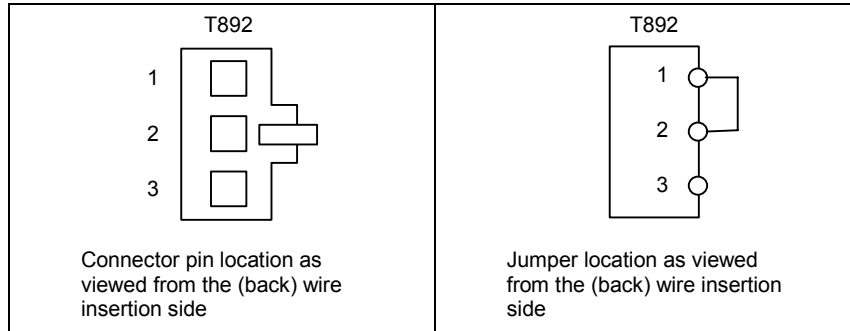

Part IV:
αi and αHVi
Series Servo
Systems

Section 25: α i and α HVi Series Servos Overview

25.1 α i and α HVi Series Servo Systems

The α HVi Series servos are high voltage models with an AC voltage input range of 400-480 VAC and include separately mounted shared power supply modules. These power supply modules offer line regeneration capability which eliminates the need for external power resistors to dissipate regenerated energy during motor deceleration. Depending on the motor rating up to six amplifiers can be connected to one power supply.

Table **2HIV-1** provides a summary of α is Series servo motors supported by the DSM324i and PACMotion controllers for general motion applications. See Section 27: for more detailed motor specifications.

Table IV-1. α is Series Servo Systems (400—480 VAC Main Power)

| Motor Model No. | Rated Torque | Encoder (built-in) | Required Amplifier | Motor Catalog No.* |
|-------------------------------|--|---------------------------|---------------------------|--|
| α 12/4000HVis | 12 Nm continuous stall torque; 4000 RPM | α iA 1000 | α SVM1-40HVi | Motor Only: ZA06B-0239-B200 Motor w/ Brake: ZA06B-0239-B500 |
| α 22/3000i | 22 Nm continuous stall torque; 3000 RPM | α iA 1000 | β SVM1-80i | Motor Only: ZA06B-247-B200 Motor w/ Brake: ZA06B-247-B500 |
| α 22/3000HVi | 22 Nm continuous stall torque; 3000 RPM | α iA 1000 | α SVM1-40HVi | Motor Only: ZA06B-0249-B200 Motor w/ Brake: ZA06B-0249-B500 |
| α 22/4000HVis | 22 Nm continuous stall torque; 4000 RPM | α iA 1000 | α SVM1-80HVi | Motor Only: ZA06B-0266-B200 Motor w/ Brake: ZA06B-0266-B500 |
| α 30/4000HVis | 30 Nm continuous stall torque; 4000 RPM | α iA 1000 | α SVM1-80HVi | Motor Only: ZA06B-0269-B200 Motor w/ Brake: ZA06B-0269-B500 |
| α 40/4000HVis | 40 Nm continuous stall torque; 4000 RPM | α iA 1000 | α SVM1-80HVi | Motor Only: ZA06B-0273-B200 Motor w/ Brake: ZA06B-0273-B500 |
| α 50/3000HVis with fan | 75 Nm continuous stall torque; 3000 RPM | α iA 1000 | α SVM1-180HVi | Motor Only: ZA06B-0276-B210 Motor w/ Brake: ZA06B-0276-B510 |

* All motors include straight shaft and key.

25.2 *ai* Series Servo Amplifier Packages

The following table shows which amplifier model is included in each *ai* Series servo package.

Table IV-2. α HVi Series Servo Amplifiers and Packages

| <i>Motor</i> | <i>Amplifier Model</i> | <i>Amplifier Catalog #</i> | <i>Amplifier Kit Catalog #</i> |
|---|------------------------|----------------------------|--------------------------------|
| α 12/4000HVis α 22/3000HVis | α SVM1-40HVi | ZA06B-6124-H104 | IC800AIHV040 |
| α 22/4000HVis α 30/4000HVis | α SVM1-80HVi | ZA06B-6124-H105 | IC800AIHV080 |
| α 40/4000HVis α 50/3000HVis with fan | α SVM1-180HVi* | ZA06B-6124-H106 | IC800AIHV180 |

*Amplifier α SVM1-180HVi requires dynamic braking module ZA06B-6079-H401.

As a convenience, amplifiers can also be ordered as a package containing all of the components required to operate the amplifier in a servo system, as detailed in the following table:

Table IV-3. α HVi Series Servo Amplifier Kits

| <i>Description</i> | <i>Package Contents*</i> | <i>Catalog #</i> |
|--|--|------------------|
| α HVi-series 40A amplifier kit | <ul style="list-style-type: none"> ■ αSVM1-40HVi Amplifier, Qty 1 ■ Amplifier connectors, ■ Bus bar kit ■ ZA06B-6073-K250, Amplifier spare Control Power Fuse, Qty 1 | IC800AIHV040 |
| α HVi-series 80A amplifier kit | <ul style="list-style-type: none"> ■ αSVM1-80HVi Amplifier, Qty 1 ■ Amplifier connectors ■ Bus bar kit ■ ZA06B-6073-K250, Amplifier spare Control Power Fuse, Qty 1 | IC800AIHV080 |
| α HVi-series 180A amplifier kit | <ul style="list-style-type: none"> ■ αSVM1-180HVi Amplifier, Qty 1 ■ Amplifier connectors ■ Bus bar kit ■ ZA06B-6073-K250, Amplifier spare Control Power Fuse, Qty 1 | IC800AIHV180 |

* Amplifier package components can also be ordered separately.

Section 26: α HVi Servo System Options

Designing a servo control system requires that you understand how the electrical and mechanical aspects of your system interact. The table below will help you select which servo options your system requires.

Table IV-4. α i Servo System Options

| Servo Option | Consider Selecting When | Catalog # | Section # |
|---|--|--|------------------|
| Motor Holding Brake | The system design includes an axis that must hold its position when power is removed | Refer to Table 2HIV-1 | 27.4 |
| Absolute Encoder Battery Backup Kit | You want to avoid having to re-reference the position when power is restored to the control | IC800ABK001 (4-axis) IC800ABK002 (1-axis) | 28.4 |
| AC Line Filters | 200—240 VAC is already available to the control cabinet and no isolation transformer is used | 5.4 kW, 3-phase: ZA81L-0001-0083#3C 10.5 kW, 3-phase: ZA81L-0001-0101#C | 23.2 |
| Pre-finished Cables | The cable lengths available from GE Fanuc are appropriate for your application | Refer to “Cable Connections” Table | Section 33: |
| Ground Clamp | CE Installation or high electrical noise environment. | ZA99L-0035-0001, Clamp Z44B295864-001, Bar | 31.3 |
| Absolute Encoder Battery Backup Connector | You want to daisy chain multiple amplifiers together to share the multi-axis battery pack IC800ABK001. | ZA06B-6093-K303 | 28.4 |

Table IV-5. α HVi Servo System Options

| Servo Option | Consider Selecting When | Catalog # | Section # |
|---|--|---|------------------|
| Motor Holding Brake | The system design includes an axis that must hold its position when power is removed | Refer to Table 2HIV-1 | 27.4 |
| Absolute Encoder Battery Backup Kit | You want to avoid having to re-reference the position when power is restored to the control | IC800ABK001 (four-axis) IC800ABK002 (one-axis) IC800ABK003, for α SVM1-180HVi Amplifier only | 28.4 |
| AC Line Filters | 400—480 VAC is already available to the control cabinet and no isolation transformer is used | ZA81L-0001-0163 ZA81L-0001-0164 | 32.2 |
| Pre-finished Cables | The cable lengths available from GE Fanuc are appropriate for your application | Refer to “Cable Connections” tables | Section 33: |
| Ground Clamp | CE Installation or high electrical noise environment. | ZA99L-0035-0001, Clamp Z44B295864-001, Bar | 31.3 |
| Absolute Encoder Battery Backup Connector | You want to daisy chain multiple amplifiers together to share the multi-axis battery pack IC800ABK001. | ZA06B-6093-K303 | 28.4 |

Section 27: Servo Motors

27.1 Servo Motor Specifications

The *ai* Series Servo system consists of a servomotor and its corresponding amplifier and cables.

Table IV-6. Specifications of the *ai* Servo Motor

| | <i>Unit</i> | <i>α22/3000i</i> |
|----------------------------|---|------------------|
| Rated torque at stall * | Nm | 22 |
| | lbf-in | 194.7 |
| Stall Current * | A (rms) | 18.4 |
| Rated Output * | kW | 4.0 |
| | HP | 5.4 |
| Rated Speed | RPM | 3000 |
| Max. Speed | RPM | 3000 |
| Encoder Resolution | Counts/Rev | |
| Absolute | 1,000,000 | |
| Flange Size | mm | |
| Peak Torque * | Nm | 64 |
| | lb-in | 566.4 |
| Rotor Inertia | Kgm ² | 0.0120 |
| | lb-in-s ² *(10 ⁻⁶) | 0.1062 |
| Rotor Inertia (with brake) | Kgm ² | 0.0126 |
| | lb-in-s ² *(10 ⁻⁶) | 0.1115 |
| Torque Constant * | Nm/A | 1.20 |
| | Lb-in/A | 10.62 |
| Back EMF Const. (1 phase)* | V _{rms} /1000 rpm | 42 |
| Resistance (1 phase) * | ohm | 0.16 |
| Mechanical Time Constant | sec | 0.004 |
| Thermal time Constant | min | 60 |
| Static friction | Nm | 1.2 |
| Weight | kg | 29 |
| | lb | 63.8 |
| Weight (with brake) | kg | 35 |
| | lb | 77 |
| Axial Load Rating | kg | 60 |
| Radial Load Rating | kg | 200 |
| Max Current | A (peak) | 80 |

* These values are standard values at 20°C with a tolerance of ±10%. The speed-torque characteristics vary, depending on the type of software, parameter setting, and input voltage of the digital servo amplifiers. (The above figures show average values.) These values may be changed without prior notice.

Servo Products Specification Guide

Table IV-7. Specifications of α 12HV*is* and α 22HV*is* Servo Motors

| | <i>Unit</i> | <i>α12/4000HV<i>is</i></i> | <i>α22/3000HV<i>i</i></i> | <i>α22/4000HV<i>is</i></i> |
|--------------------------------|----------------------------|--|---|--|
| Rated torque at stall * | Nm | 12 | 22 | 22 |
| | lbf-in | 106.2 | 194.7 | 194.7 |
| Stall Current * | A (rms) | 6.7 | 91.11 | 15.5 |
| Rated Output * | kW | 2.5 | 4.04 | 4.5 |
| | HP | 3.4 | 5.4 | 6 |
| Rated Speed | RPM | 3000 | 3000 | 3000 |
| No Load Speed | RPM | 4000 | 3000 | 4000 |
| Encoder Resolution | Counts/Rev absolute | 1,000,000 | 1,000,000 | 1,000,000 |
| Flange Size | mm | 130 | 174 | 174 |
| Peak Torque * | Nm | 46 | 64 | 70 |
| | lbf-in | 407.14 | 566.4 | 619.6 |
| Rotor Inertia | Kgm ² | 0.00228 | 0.012 | 0.00527 |
| | lb-in-s ² | 0.02018 | 0.1062 | 0.04664 |
| Rotor Inertia (with brake) | Kgm ² | 0.00235 | 0.0126 | 0.00587 |
| | lb-in-s ² | 0.0208 | 0.1115 | 0.05195 |
| Torque Constant * | Nm/A | 1.8 | 2.41 | 1.42 |
| | Lbf-in/A | 15.9 | 21.3 | 12.6 |
| Back EMF Const. (1 phase) * | V _{rms} /1000 rpm | 63 | 84 | 50 |
| Resistance (1 phase) * | ohm | 0.84 | 0.66 | 0.25 |
| Mechanical Time Constant | sec | 0.002 | 0.004 | 0.002 |
| Thermal time Constant | min | 25 | 60 | 30 |
| Static friction | Nm | 0.3 | 1.2 | 0.8 |
| Weight | kg | 11.9 | 29 | 17 |
| | lb | 26.2 | 63.8 | 37.48 |
| Weight (with brake) | kg | 14.1 | 35 | 23 |
| | lb | 31.1 | 77 | 50.7 |
| Axial Load Rating | kg | 20 | 60 | 60 |
| | lb | 44 | 132 | 132 |
| Radial Load Rating | kg | 70 | 200 | 200 |
| | lb | 154 | 440 | 440 |
| Max Current | A (peak) | 40 | 40 | 80 |

*These values are standard values at 20°C with a tolerance of $\pm 10\%$. The speed-torque characteristics vary, depending on the type of software, parameter setting, and input voltage of the digital servo amplifiers. (The above figures show average values.) These values may be changed without prior notice.

Servo Products Specification Guide

Table IV-8. Specifications of α 30HV*is*, α 40HV*is* and α 50HV*is* Servo Motors

| | <i>Unit</i> | <i>α30/4000HV<i>is</i></i> | <i>α40/4000HV<i>is</i></i> | <i>α50/3000HV<i>is</i> with Fan</i> |
|--------------------------------|----------------------------|--|--|---|
| Rated torque at stall * | Nm | 30 | 40 | 75 |
| | lbf-in | 265.5 | 354.0 | 663.8 |
| Stall Current * | A (rms) | 15.9 | 18.1 | 39.6 |
| Rated Output * | kW | 5.5 | 5.5 | 14 |
| | HP | 7.4 | 7.4 | 19 |
| Rated Speed | RPM | 3000 | 3000 | 3000 |
| No Load Speed | RPM | 4000 | 4000 | 3000 |
| Encoder Resolution | Counts/Rev | 1,000,000 | 1,000,000 | 1,000,000 |
| Flange Size | mm | 174 | 174 | 174 |
| Peak Torque * | Nm | 100 | 115 | 215 |
| | lbf-in | 885.1 | 1017.9 | 1903 |
| Rotor Inertia | Kgm ² | 0.00759 | 0.0099 | 0.0145 |
| | lb-in-s ² | 0.06717 | 0.8761 | 0.1283 |
| Rotor Inertia (with brake) | Kgm ² | 0.00819 | 0.0105 | 0.0151 |
| | lb-in-s ² | 0.7248 | 0.0929 | 0.1336 |
| Torque Constant * | Nm/A | 1.9 | 2.21 | 1.9 |
| | lbf-in/A | 16.8 | 19.6 | 1638 |
| Back EMF Const. (1 phase) * | V _{rms} /1000 rpm | 66 | 77 | 66 |
| Resistance (1 phase) * | ohm | 0.25 | 0.23 | 0.1 |
| Mechanical Time Constant | sec | 0.002 | 0.001 | 0.001 |
| Thermal time Constant | min | 35 | 40 | 30 |
| Static friction | Nm | 0.8 | 1.2 | 1.8 |
| Weight | kg | 23 | 28 | 39 |
| | lb | 50.7 | 61.7 | 86.0 |
| Weight (with brake) | kg | 29 | 34 | 42 |
| | lb | 63.9 | 75.0 | 92.6 |
| Axial Load Rating | kg | 60 | 60 | 60 |
| | lb | 132 | 132 | 132 |
| Radial Load Rating | kg | 200 | 200 | 200 |
| | lb | 440 | 440 | 440 |
| Max Current | A (peak) | 80 | 80 | 180 |

*These values are standard values at 20°C with a tolerance of $\pm 10\%$. The speed-torque characteristics vary, depending on the type of software, parameter setting, and input voltage of the digital servo amplifiers. (The above figures show average values.) These values may be changed without prior notice.

27.2 *ai* and *αHVis* Series Motor Speed–Torque Curves

The curves shown in the following figure illustrate the relationship between the speed of the motor and the output torque. The motor can operate continuously at any combination of speed and torque within the prescribed continuous operating zone. The limit of the continuous operating zone is determined with the motor's ambient temperature at 20°C and its drive current as pure sine wave. The curves reflect peak torque limits based on maximum current of the servo amplifier unit.

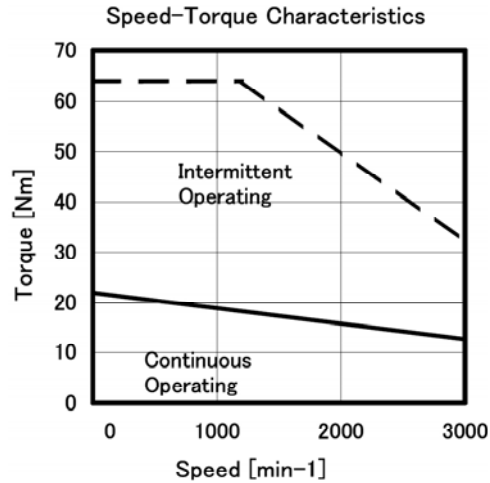

Figure IV-1. *αi* Series Servo Motor Speed-Torque Curve (*α22/3000i*)

Servo Products Specification Guide

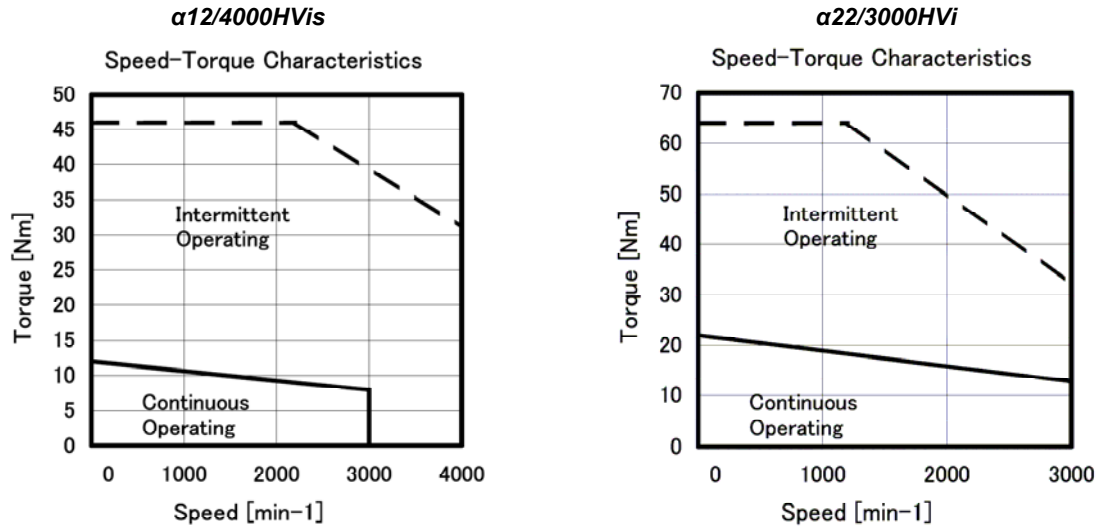

Figure IV-2. αHVIs Series Servo Motor Speed-Torque Curves (α12/4000HVIs and α22/3000HVIs)

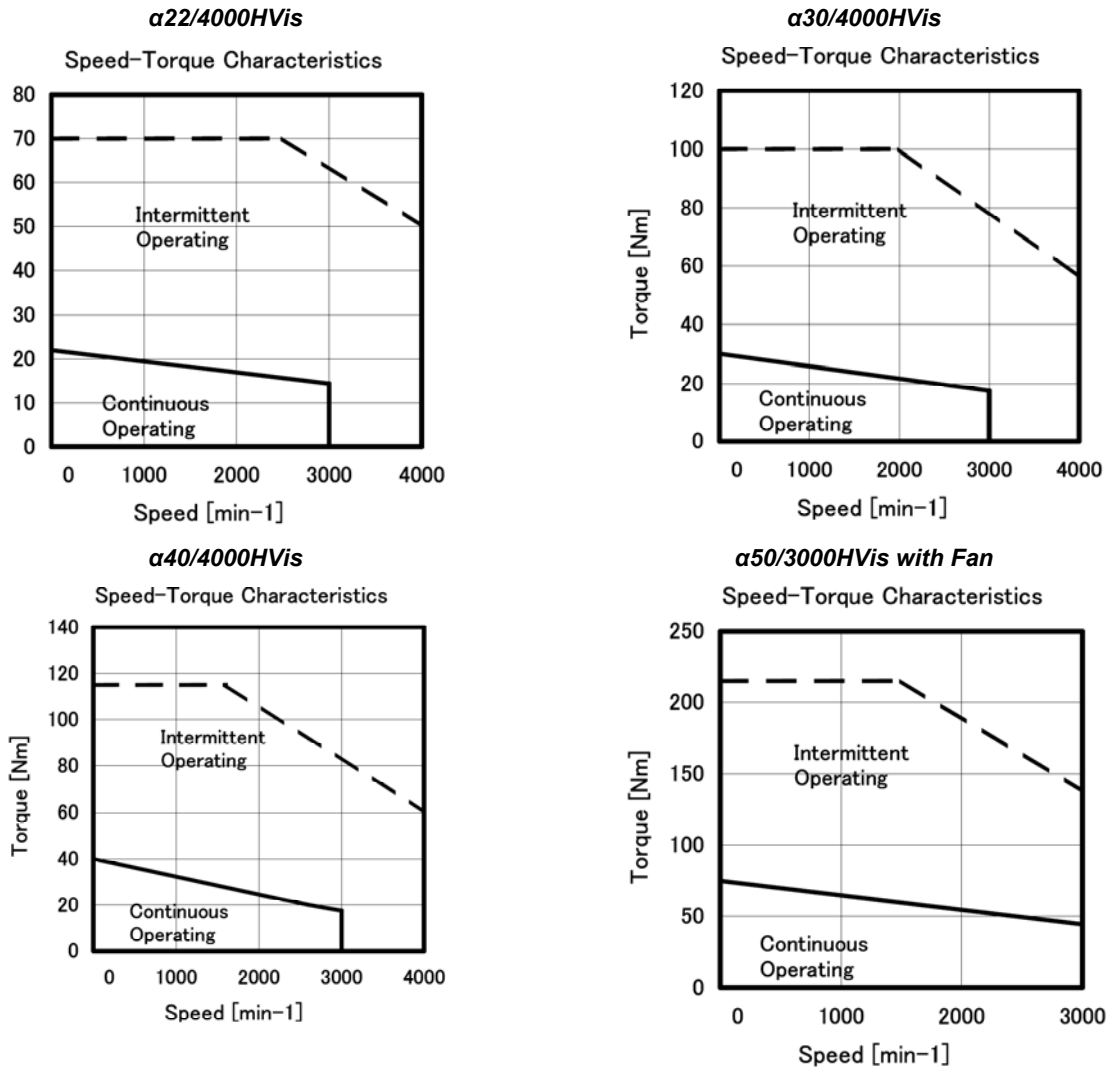
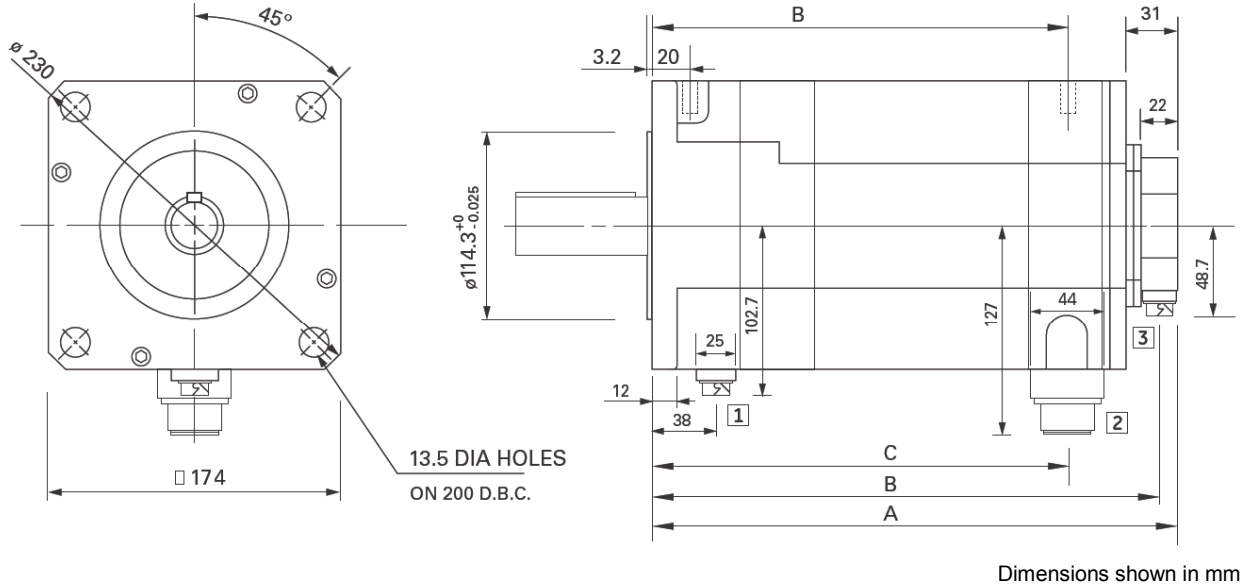

Figure IV-3. αHVIs Series Servo Motor Speed-Torque Curves(α22/4000HVIs, α30/4000HVIs, α40/4000HVIs and α50/3000HVIs with Fan)

27.3 Motor Outline Drawings

ai Motor



Motor

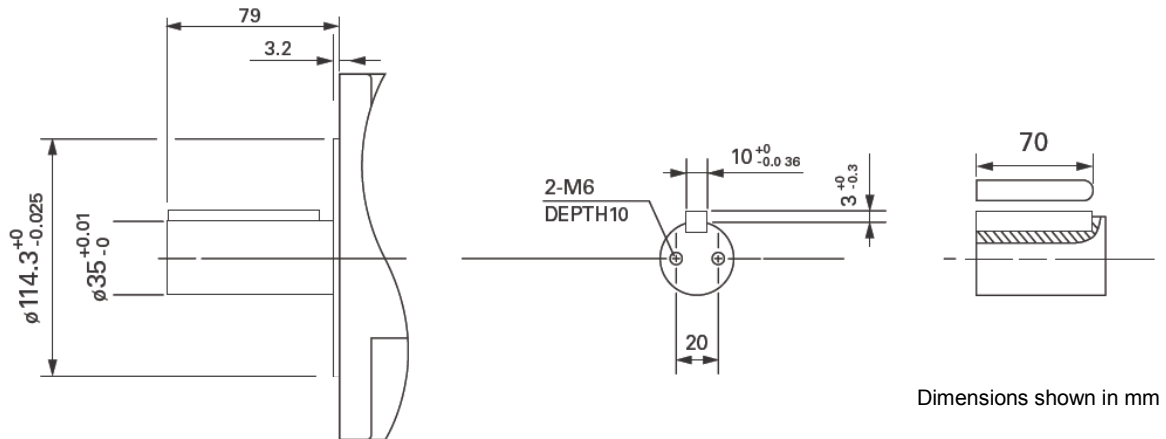

Shaft Detail

| Dimension | $\alpha 22/3000i$ | Connector | Description |
|--------------|-------------------|-----------|------------------|
| A | 276mm | 1 | Brake (optional) |
| A with brake | 317mm | 2 | Power |
| B | 265mm | 3 | Encoder |
| B with brake | 306mm | | |
| C | 215mm | | |
| C with brake | 256mm | | |

Figure IV-4. ai Series Servo Motor Outline Drawing ($\alpha 22/3000i$)

Servo Products Specification Guide

aHVi Motors

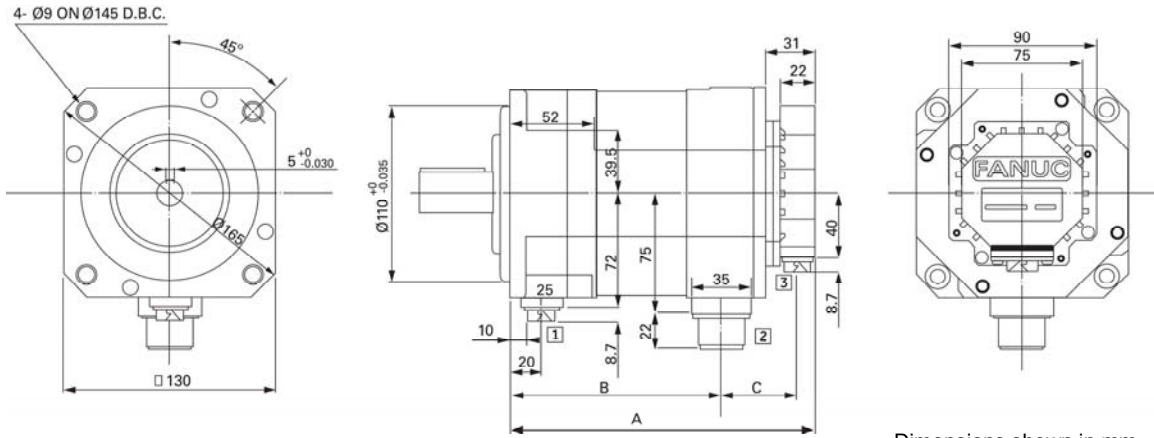

Dimensions shown in mm

Motor

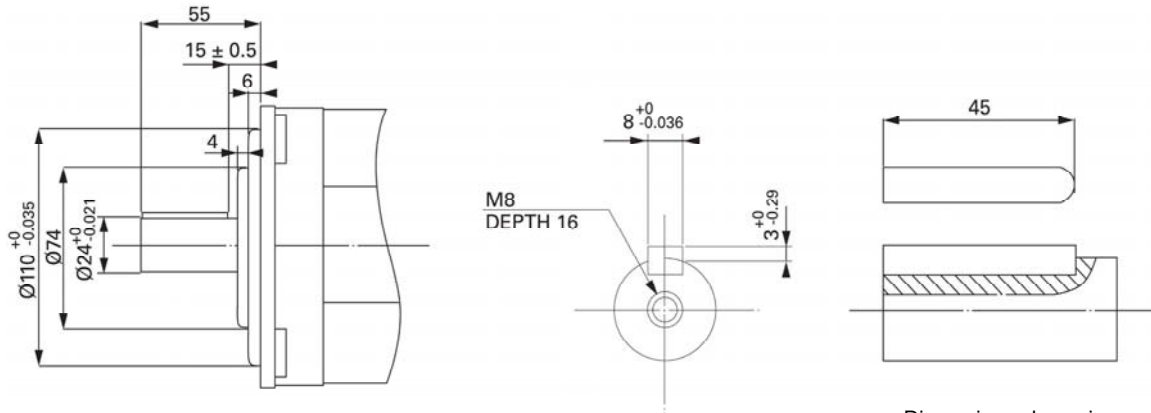

Dimensions shown in mm

Shaft Detail

| <i>Dimension</i> | <i>$\alpha 12/4000HVis$</i> |
|------------------|--|
| A | 222mm |
| A with brake | 247mm |
| B | 164mm |
| B with brake | 189mm |
| C | 47mm |
| C with brake | 47mm |

| <i>Connector</i> | <i>Description</i> |
|------------------|--------------------|
| 1 | Brake (optional) |
| 2 | Power |
| 3 | Encoder |

Figure IV-5. $\alpha 12/4000HVis$ Series Servo Motor Outline Drawing

Servo Products Specification Guide

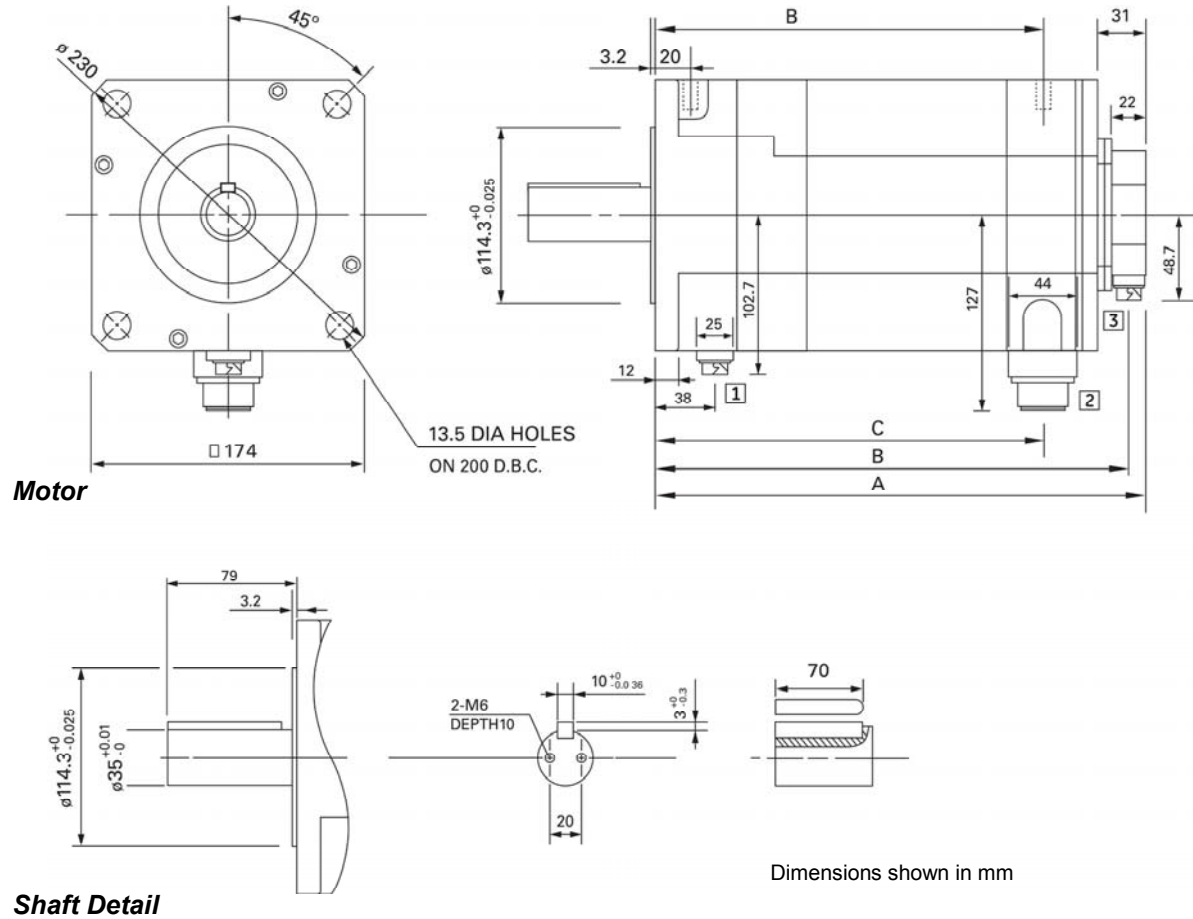

| Dimension | $\alpha 22/4000HVis$ | $\alpha 30/4000HVis$ | $\alpha 40/4000HVis$ |
|--------------|----------------------|----------------------|----------------------|
| A | 202mm | 239mm | 276mm |
| A with brake | 243mm | 280mm | 317mm |
| B | 191mm | 228mm | 265mm |
| B with brake | 232mm | 269mm | 306mm |
| C | 151mm | 178mm | 215mm |
| C with brake | 182mm | 219mm | 256mm |

| Connector | Description |
|-----------|------------------|
| 1 | Brake (optional) |
| 2 | Power |
| 3 | Encoder |

Figure IV-6. $\alpha 22/4000HVis$, $\alpha 30/4000HVis$, $\alpha 40/4000HVis$ Series Servo Motor (with Brake) Outline Drawing

Servo Products Specification Guide

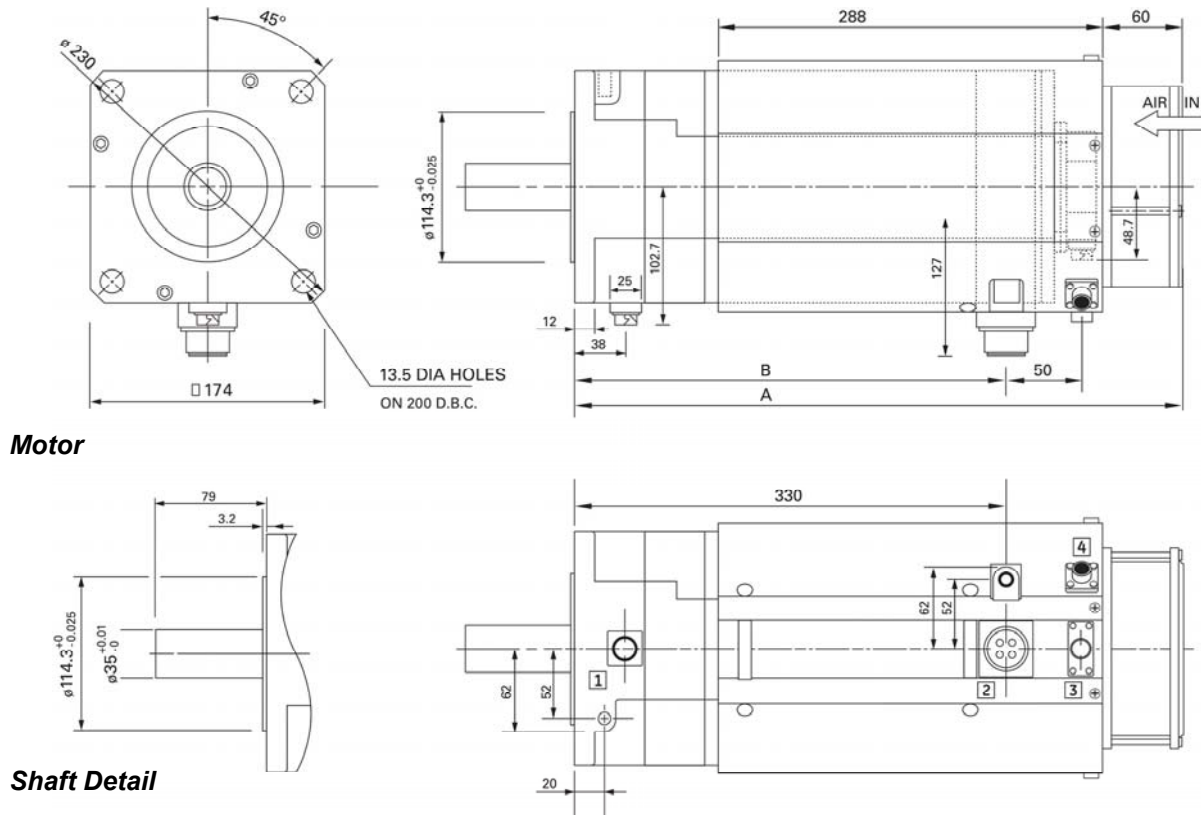

Motor

Shaft Detail

| Dimension | α50/3000Vis | Connector | Description |
|------------------|--------------------|------------------|--------------------|
| A | 416mm | 1 | Brake (optional) |
| A with brake | 457mm | 2 | Power |
| B | 289mm | 3 | Encoder |
| B with brake | 330mm | 4 | Fan |

Note: The motor does not include a circuit breaker for protecting the fan. Prepare such a circuit breaker in the power magnetics cabinet.

Figure IV-7. α50HV_i Series Servo Motor with Fan Outline Drawing

27.4 Built-in Brake

The built-in holding brake is used to prevent movement on horizontal axes or falling along the vertical axis when the servo motor control is turned off. Brakes are spring-set and electrically released and are designed for holding stationary loads only. Using the holding brake to stop a moving axis may damage the brake or severely reduce its service life.

The specifications of the built-in brakes are listed in the following table.

Table IV-9. α i and α HVis Motor Holding Brake Specifications

| <i>Motor Model</i> | | <i>Unit</i> | <i>α12HVis</i> | <i>α22i, α22HVi, α22HVVis, α30HVVis, α40HVVis, α50HVVis with fan</i> |
|----------------------|---------|-----------------------|----------------------------------|--|
| Brake Holding Torque | | Nm | 8 | 35 |
| | | lbf-in | 70.8 | 309.8 |
| Response Time | Release | msec | 160 | 160 |
| | Brake | msec | 30 | 30 |
| Power Supply | Voltage | VDC | 24 (\pm 10%) | |
| | Current | A | 1.1 | 1.2 |
| | Power | W | 26 | 29 |
| Weight Increase | | kg | 2.2 | 6.0 |
| Inertia Increase | | kg-m ² | 0.00007 | 0.0006 |
| | | lbf-in-s ² | 0.0006195 | 0.00531 |

The values shown above are standard values at 20°C.

Brake Connections

Manufacturer: Japan Aviation Electronics Industry

Manufacturer specification: JN2AS04MK2-R

This connector is drip-proof.

The shape and pin layout of the connector are shown below.



Connections: 1=BK, 2=BK, 3=NC (Not Connected), 4=GND

BK indicates a power supply (24 VDC, 0 VDC) for the brake.

The brake is nonpolarized.

Note: Since pin 4 is connected to the brake housing, it can be used when the shield wire of a brake cable needs to be connected.

Brake Power Supply Circuit

The following table lists the recommended parts and their specifications to be used as components of a user-built brake circuit. Configure a brake circuit by referencing the following brake connection diagram and the recommended parts as shown below.

Table IV-10. ai and aHVi Holding Brake Circuit Components

| Name | Model No. | Name of Manufacturer | Specifications |
|----------------|--------------------------|--|---|
| Rectifier* | D3SB60 A06B-6050-K112 | Shindengen Electric Mfg. Co., Ltd. | Withstand voltage 400V min. Maximum output current: 2.3 A (with no fins) |
| Switch | N/A | N/A | Rated load capacity (resistance load) 250VAC 10A / 30VDC 10A or more |
| Spark Killer | XEB0471 | Okaya Electric Ind. Co., Ltd. | 47 ohm/0.1 μF Withstand voltage 400V min |
| Surge Absorber | ERZV10D820 | Matsushita Electric Industrial Co., Ltd. | Varistor voltage 82V Max allowable voltage 50 VAC |

* At an ambient temperature of 20°C, the temperature of the rectifier rises to about 60°C when one brake axis is used, or to about 90°C when two brake axes are used. Use a radiator fin as required.

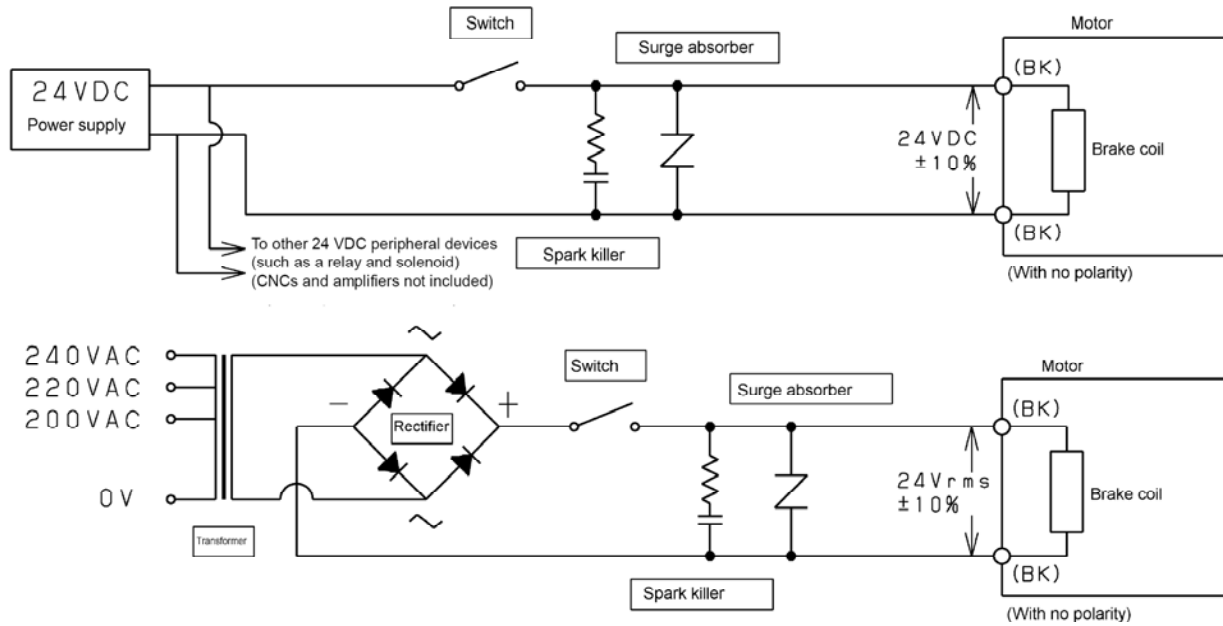

Figure IV-8. Connecting Motor Holding Brake Control and Power Circuit

Servo Products Specification Guide

1. Use a 24 VDC power supply as the power supply for the *ai* series servo motor brake. Power (equivalent to 24 Vrms) produced by full-wave rectification after transforming commercial power (50 Hz/60 Hz) is also available.
2. Use a power supply separate from the 24-V power supply for the amplifier as the power supply for the brake. If the control power supply is also used for the brake, an amplifier malfunction or another danger may occur. The power supply for a relay, solenoid, or another peripheral device can be used for the brake. Be careful of the power capacity and changes in voltage due to changes in load.
3. For full-wave rectification, transform the secondary side voltage obtained during energization of the brake into approximately 29VAC by taking voltage drop in the rectifier or cable into account.
In this case, check the power capacity and power voltage fluctuations sufficiently and then make sure the fluctuations of the voltage applied to the brake during energization falls within 24 Vrms $\pm 10\%$. Switch the transformer's primary side input to a desired position such as 100-110-120 VAC or 200-220-240 VAC.
4. If the contact is installed on the DC side (at the position shown in the figure), the life of the contact is generally shortened due to the surge voltage at brake off. Provide an adequate contact capacity and always use a surge absorber and spark killer for protecting the contact.
5. You can use either positive or negative power pin to connect the brake because the brake coil is nonpolarized.
6. Use a shielded cable as required.

| |
|---------|
| Caution |
|---------|

Observe the following precautions when motors with built-in brakes are used.

1. **A built-in brake is used as a holding brake to prevent a vertical axis from falling or a horizontal axis from being moved when torque is removed from the motor. This brake functions as a brake at an emergency stop or power failure, but should not be used to decrease the stop distance during ordinary deceleration.**
2. **The brake cannot be used to assist stopping the motor under servo control. This causes abnormal heating of the motor.**
3. **Match the timing of brake release (axis release) to the timing of servo on (motor energization) as much as possible. Similarly, match the timing of brake engagement to the timing of servo off as much as possible.**
4. **The total length of a motor with a built-in brake is much longer than that of the motor with no built-in brake. Be careful not to apply excessive force to the opposite side of the mounting flange or to apply excessive acceleration to the entire motor.**

27.5 Motor Connections

Table IV-11. α 12HVis Motor Connections

Power Connectors

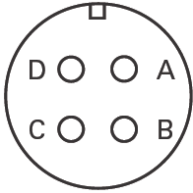

| Description | Motor Connector | GE Fanuc Part Numbers |
|-------------|---------------------|--|
| A | U | α 12HVis Straight: Z44A730434-G20 Right angle: Z44A730434-G19 |
| B | V | |
| C | W | |
| D | Ground (Motor Body) | All others: Straight: Z44A730434-G18 Right angle: Z44A730434-G17 |

Serial Encoder Connectors

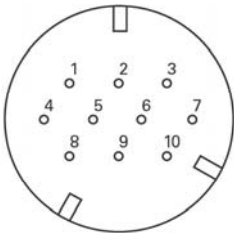

All α HVis, α HVi and α i Motors

| Description | Motor Connector | Amplifier JF1 Connector |
|-----------------|-----------------|----------------------------------|
| N/C | 1 | 1—4, 8, 10, 11, 13, 15, 17—19 |
| N/C | 2 | |
| RD | 6 | 5 |
| *RD | 5 | 6 |
| +5 VDC | 8,9 | 9, 20 |
| 0 VDC | 7,10 | 12, 14 |
| +6 VA (battery) | 4 | 7 |
| Frame Ground | 3 | 16 |
| Cable Shield | 3 | 16 |

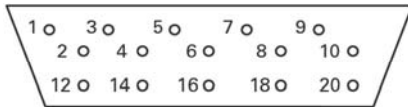

α HVi Amplifier (JF1)

Brake Connector



α HVis, α HVi and α i Brake

| Description | α iS Motor Connector | GE Fanuc Part Numbers |
|--------------|-----------------------------|-----------------------------------|
| Earth (case) | 4 | Right angle: ZA06B-6114-K213#E |
| Brake VDC | 1 | |
| Brake VDC | 2 | Straight: ZA06B-6114-K213#S |
| N/C | 3 | |

27.6 Cooling Fan

The α50/3000HV is servo motor includes a cooling fan.

Table IV-12. Cooling Fan Specifications

| | | |
|--------------------------------|----------------------|----------------|
| Input voltage | Single-phase 200 VAC | |
| | 50 Hz | 60 Hz |
| | 170 to 220 VAC | 170 to 242 VAC |
| Rated input | 31W ±10% | 30W ±10% |
| Rated current | 0.23A ±10% | 0.2A ±10% |
| Degree of protection (IEC34-5) | IP00 | |

Connecting the Fan Power

Manufacturer: Japan Aviation Electronics Industry

Manufacturer specification: JN2AS04MK2X-R

GE Fanuc Part Numbers:

ZA06B-6114-K214#E (right angle)

ZA06B-6114-K214#S (straight)

This connector is not drip-roof.

The shape and pin layout of the connector are shown below.

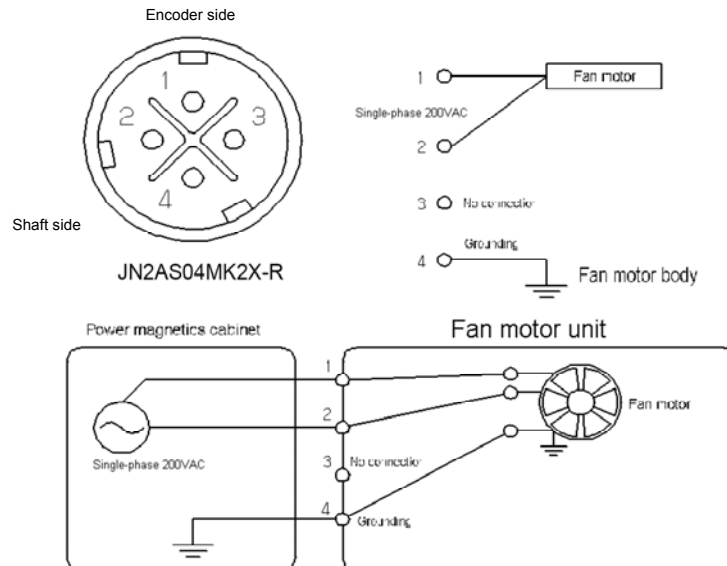

Section 28: α SVM1 Amplifiers

28.1 Amplifier Specifications

Table IV-13. α SVM1 Series Amplifier Electrical Specifications

| <i>Item</i> | <i>αSVM1-40HVi</i> | <i>αSVM1-80HVi</i> | <i>αSVM1-180HVi</i> |
|----------------------------------|---|---|---|
| Type | 60mm-wide with external fin | 60mm-wide with external fin | 150mm-wide with external fin |
| Power Supply Voltage (amplifier) | 3-Phase 400-480VAC | 3-Phase 400-480VAC | 3-Phase 400-480VAC |
| Power Supply Voltage (control) | Single-phase 200 VAC to 240 VAC (input from connector CX1A) | Single-phase 200 VAC to 240 VAC (input from connector CX1A) | Single-phase 200 VAC to 240 VAC (input from connector CX1A) |
| Allowable Voltage Deviation | -15% to +10% (including voltage variation due to load) | -15% to +10% (including voltage variation due to load) | -15% to +10% (including voltage variation due to load) |
| Power Frequency | 50/60Hz, ± 1 Hz | 50/60Hz, ± 1 Hz | 50/60Hz, ± 1 Hz |
| Power Supply Imbalance | $\pm 5\%$ of the rated voltage or less | | |
| Power Supply Impedance | The voltage variation must be within $\pm 7\%$ when a maximum output is produced for voltage at non-load time (power running and regeneration). | | |
| Dynamic Brake Module | NA | NA | ZA06B-6079-H401 |

Table IV-14. α HVi Series Amplifier Environmental Specifications

| Item | Specification |
|---|----------------------------------|
| Ambient Temperature Operation Storage | 0 to 55 °C -20 to 60 °C |
| Humidity | 90% RH or below (non-condensing) |
| Vibration | Below 0.5 G |

28.2 α HVi Series Amplifier Status LED and Alarm Functions

The servo amplifier unit can detect error conditions and provide alarm information.

The LEDs on the front of the amplifier provide a visual indication of system status by indicating, for example, when the motor and amplifier are ready to function.

- POWER LED (green) indicates the logic 24 VDC power is present.
- DC LINK CHARGED LED (red) indicates that the amplifier has high (motor) voltage DC present.
- LINK LED (green) indicates that the FSSB (fiber optic) interface is functioning.
- ALM LED (yellow) is turned ON when an alarm condition is detected. When an alarm is detected, power is dropped and the motor is stopped by dynamic braking action. Alarm information is additionally displayed as diagnostic data in the GE Fanuc DSM324i motion controller. The amplifier control power must be cycled to reset this alarm state. The table below details the alarm conditions the α i Series Servo Amplifier can detect.

Servo Products Specification Guide

Table IV-15. α HVi Series Servo Amplifier Alarms

| Alarm Condition | Description |
|------------------------------|---|
| DC Link Under-Voltage | Issued when the DC voltage in the main circuit power supply is abnormally low. Indicates low AC mains power dip or hardware problem. Make sure the plug-in (gray faceplate) circuit board is securely seated in the amplifier base. Replace amplifier. |
| DC Link Over-Voltage | Issued when the DC voltage in the main circuit power supply is abnormally high. Indicates high AC mains power or hardware problem. Make sure the plug-in (gray faceplate) circuit board is securely seated in the amplifier base. May also be caused by excessive regenerated power. Increase acceleration/deceleration time and/or add additional regenerative discharge capacity. Replace amplifier. |
| Excessive Deceleration Power | <p>If no external regeneration resistor is used, the discharge resistor thermal sensor jumper is missing on connector CXA20. This input requires a normally closed contact for normal operation.</p> <p>When using an external regeneration resistor, the thermal sensor in the regeneration resistor has tripped. Indicating excessive regenerated power load to the regeneration resistor. Use a meter to confirm an open circuit on the thermal sensor leads. Make sure the plug-in (gray faceplate) circuit board is securely seated in the amplifier base. Increase capacity of external regeneration resistor or decrease deceleration rate or frequency, and/or the top speed from which the axis must decelerate.</p> |
| Control Power Under-Voltage | The 24 VDC control power is below 21.6 VDC. Check the supply voltage level and make sure the CXA19A and CXA19B connectors are secure and associated cables are wired correctly. Replace amplifier. |
| Internal Cooling Fan Stopped | Fan is jammed, has failed or is not connected. Check for foreign material in fan blades. Make sure fan is plugged in. Make sure the plug-in (gray faceplate) circuit board is securely seated in the amplifier base. Replace amplifier. |
| IPM Alarm | Excessive current in the power transistors. Phase to phase or phase to ground short circuit on motor power output. Make sure the plug-in (gray faceplate) circuit board is securely seated in the amplifier base. Possible incorrect phase connection of the motor power wiring. Motor type code must be configured correctly in the GE Fanuc controller. Disconnect motor power leads from amplifier and reset E-stop condition. If IPM alarm occurs replace amplifier. If no IPM alarm the problem is in the motor or motor power cable. Check for electrical shorts in the motor power cable or motor winding shorted to frame ground. |
| IPM Overheat | Issued when the temperature inside the amplifier becomes so high that the thermostat trips. Make sure the plug-in (gray faceplate) circuit board is securely seated in the amplifier base. Check that the heat sink cooling fan (if applicable) is running. Make sure the ambient temperature around the amplifier is 55°C or lower. Check that the motor load is within the rating of the motor. |
| Motor Over-current | Issued when an abnormally high current is detected in the main circuit. Make sure the plug-in (gray faceplate) circuit board is securely seated in the amplifier base. Check for electrical shorts in the motor power cable or motor winding shorted to frame ground. Possible incorrect phasing on motor power wiring. Motor type code may be configured incorrectly in the DSM324 or PACMotion controller. Possible excessive force loading on motor. |
| FSSB Communication Error | FSSB connector or cable failure. Check the connections to the COP10A and COP10B connectors. Try replacing the optical cable. Replace amplifier. |

28.3 Amplifier External Dimensions

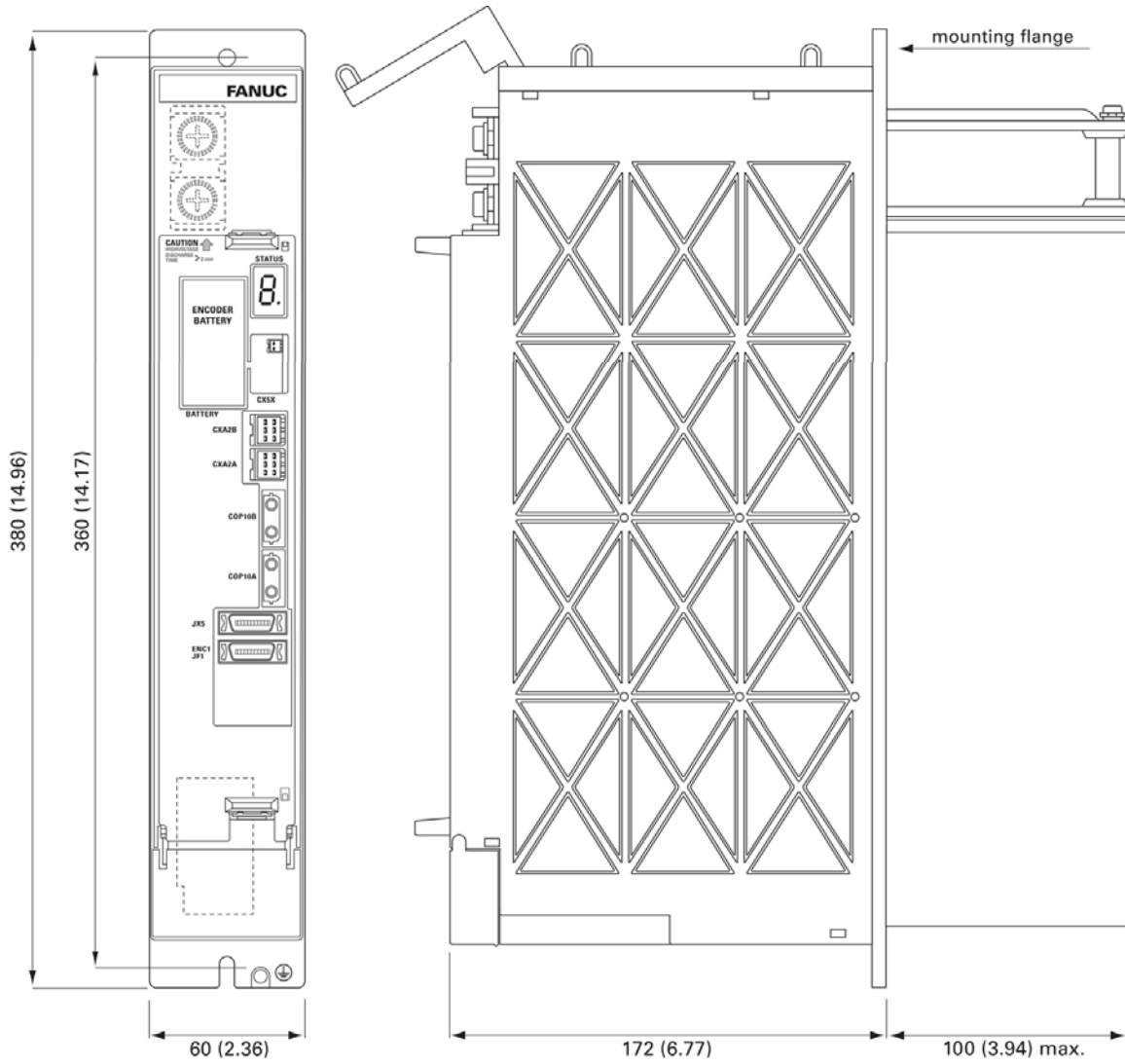

Figure IV-9. External Dimensions of α SVM1-40HVi and α SVM1-80HVi Amplifiers

Servo Products Specification Guide

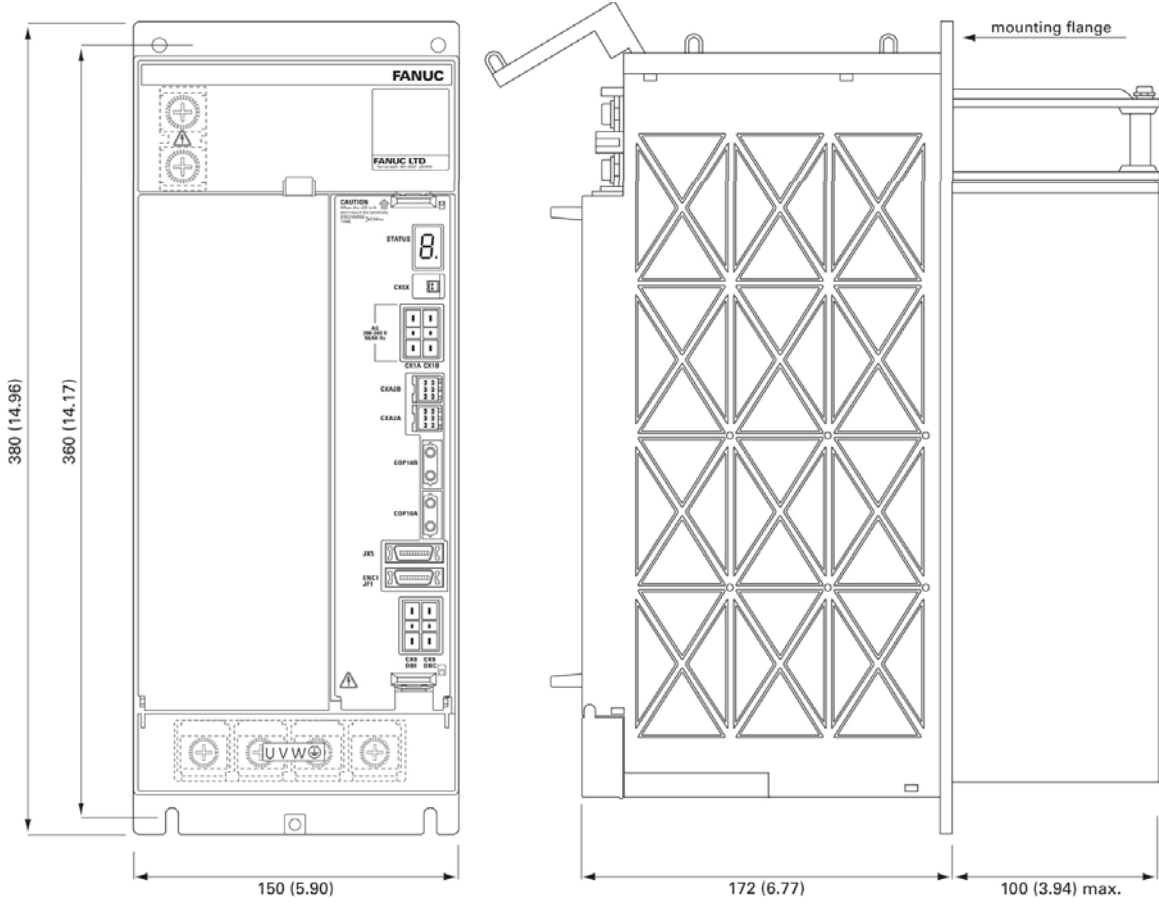

Figure IV-10. External Dimensions of α SVM1-180HVi Amplifier

28.4 Dynamic Braking Module Dimensions

The SVM1-180i requires a dynamic brake module (DBM), ZA06B-6079-H401. The DBM is used to immediately stop the motor at emergency stop or during servo alarms. Other amplifiers contain a similar function.

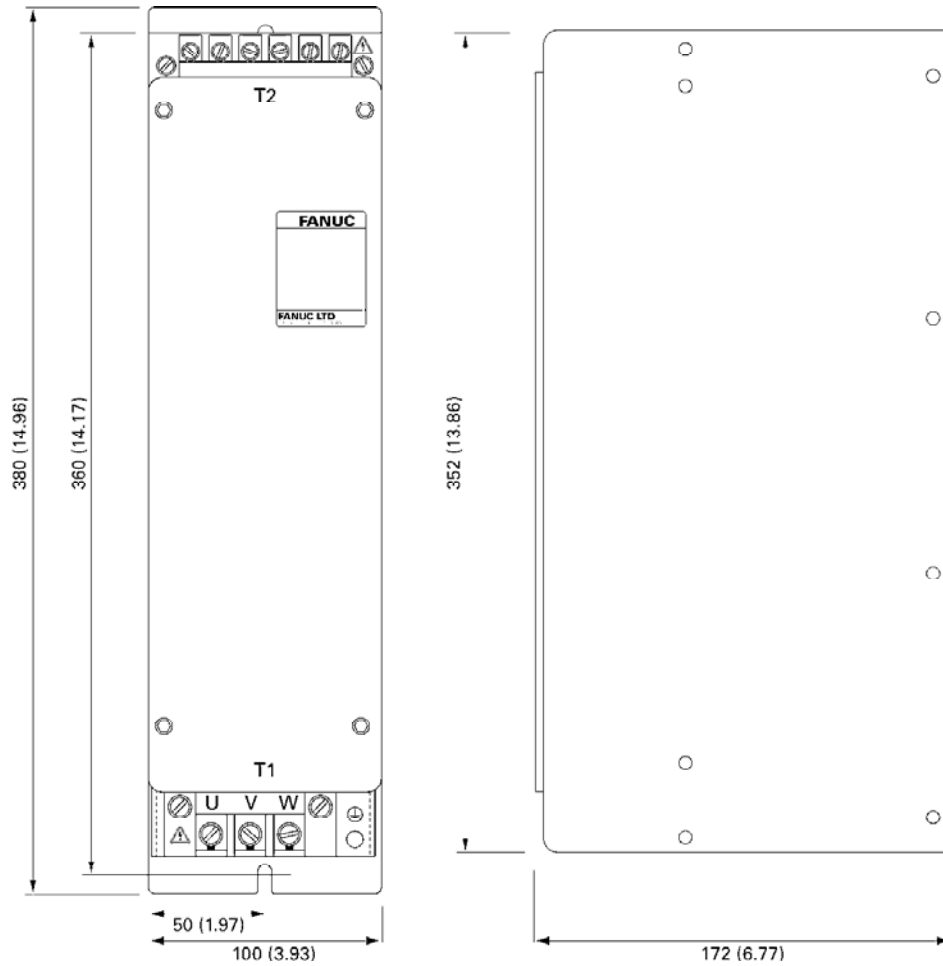

Figure IV-11. Dynamic Braking Module Outline Drawing

28.5 Power Supply Dimensions

Four power supply modules, PSM-11HVi, PSM-18HVi, PSM-30HVi and PSM-45HVi, are available for use with the α HVi Series servo system.

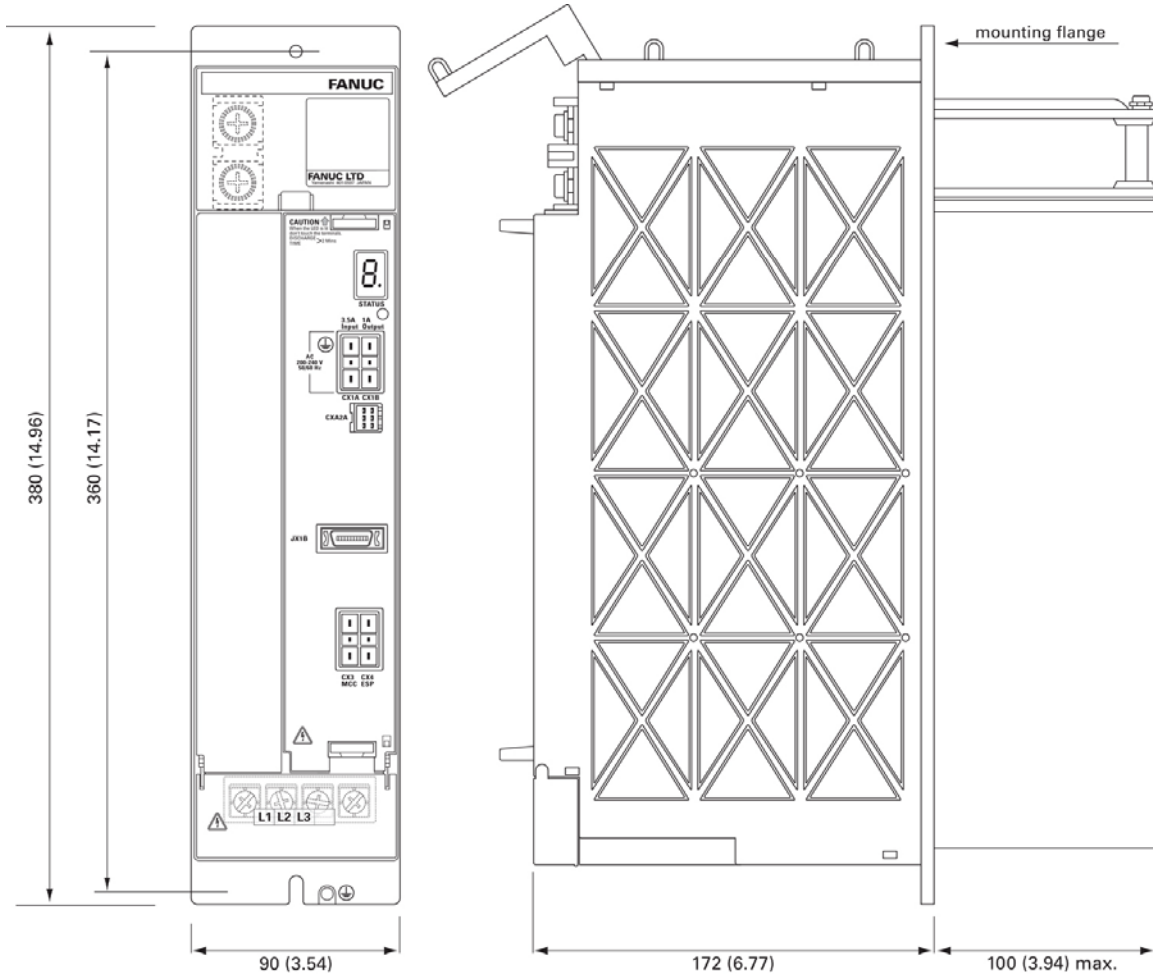

Figure IV-12. Power Supply Modules PSM-11HVi and PSM-18 HVi Outline Drawing

Servo Products Specification Guide

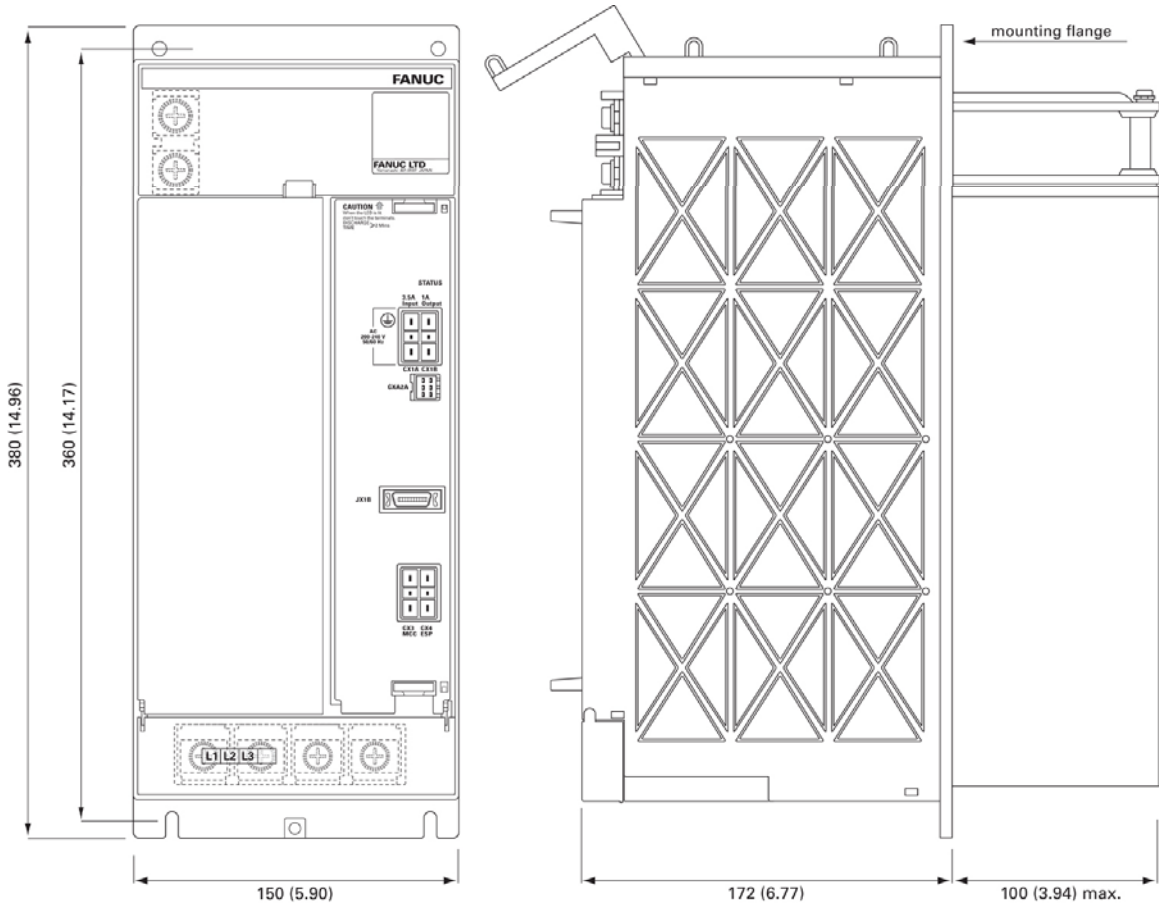

Figure IV-13. Power Supply Modules PSM-30HVi and PSM-45 HVi Outline Drawing

28.6 Absolute Encoder Battery Options

The α_i , α HVi and α HVis Series servomotors feature a built-in absolute encoder that requires an encoder battery pack. This pack allows the encoder's position information to be maintained so that the machine does not need to be re-referenced to a home position every time power is restored to the servo system.

The encoder contains an integral capacitor that will maintain the encoder backup voltage for approximately 10 minutes. This allows battery change without loss of absolute position data.

There are two encoder battery backup options for the α HVi Series amplifiers:

- a snap-on lithium battery pack that will support a single amplifier
- a panel mounted battery pack for up to four amplifiers that uses standard D cell alkaline batteries.

Table IV-16. Battery Kits and Accessories

| Battery Kits and Accessories | αSVM1-40HVi and αSVM1-80HVi | αSVM1-180HVi |
|---------------------------------------|--|---------------------------------------|
| Panel Mounted Encoder Battery Kit | IC800ABK001 | IC800ABK001 |
| Built-in Lithium Encoder Battery Kit* | IC800ABK002 | IC800ABK003 |
| Lithium Battery Pack | ZA06B-6114-K504 | ZA06B-6114-K504 |
| Battery Holder | ZA06B-6114-K505 | ZA06B-6114-K506 |

* Includes the lithium battery pack and battery holder. Replacement battery packs can be ordered separately.

Battery Connection Method for Single Amplifiers

For optimal panel space utilization, a small lithium battery pack IC800ABK002 or IC800ABK003 is available that snaps onto the amplifier housing (see figure below). An integral pigtail cable plugs directly into the CX5X connector on the faceplate of the amplifier. One battery is required for each amplifier. The lithium battery service life is approximately two years.

Installation

1. Make sure 24V control power is applied to the amplifier (if trying to hold position on an existing system).
2. Place system in an E-stop condition.
3. Remove AC power from the amplifier.
4. Remove the old battery (if applicable).
5. Place battery into plastic cover.
6. Snap cover onto amplifier housing.
7. Attach battery cable to amplifier CX5X connector as indicated in diagram making sure polarity is correct.

Notes:

- Do not attempt to connect multiple amplifiers to one IC800ABK002 or IC800ABK003 battery kit.
- Replacement CX5 battery connectors are available as kit number ZA06B-6093-K303

Servo Products Specification Guide

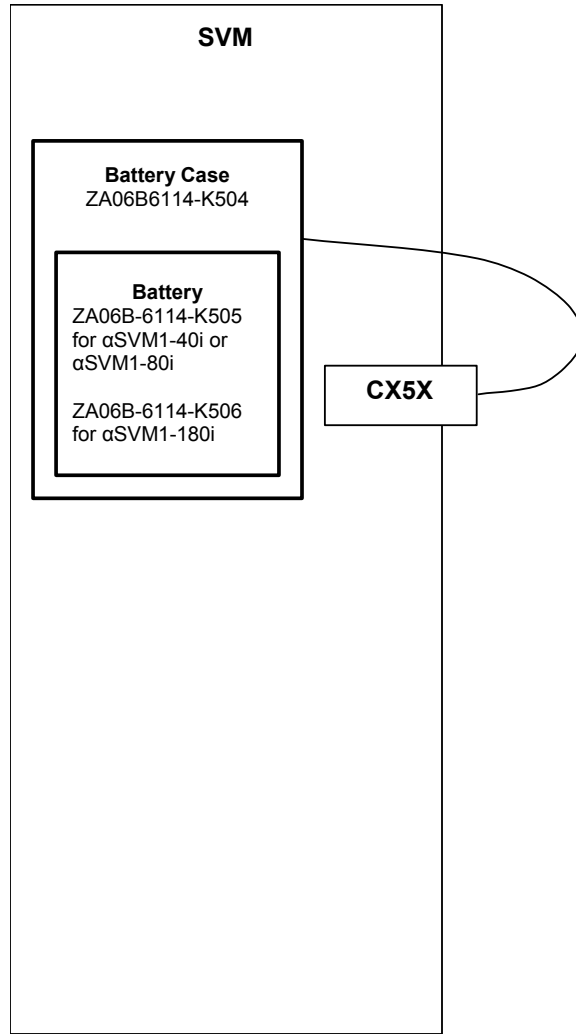

Figure IV-14. Installing the Absolute Encoder Battery Pack (One-Axis)

Connection Method for Multiple Amplifiers

To utilize the absolute capability for multiple amplifiers, the IC800ABK001 panel mounted battery pack must be installed.

The Absolute Encoder Battery Kit (IC800ABK001) contains the following:

- One battery holder (ZA06B-650-K060)
- Four D-cell, alkaline batteries (ZA98L-0031-0005)

One kit provides battery backup for up to four absolute encoders. The user is responsible for manufacturing the cable used to connect the battery pack to the amplifier. The battery connection is made to the CXA2A connector on the last amplifier in the sequence supported by the battery pack. Terminals CXA2A-B3 (6V) and CXA2A-A2 (0V) are used and wire should be 0.3 mm² minimum cross sectional area. The battery power is distributed to the other amplifiers in the sequence by daisy chaining the CXA2B connections to the CXA2A connections on adjacent amplifiers. See Section 33: aHVi Series Servo System Connection for more detail.

The battery service life is approximately one year and we recommend a yearly replacement schedule.

The IC800ABK001 battery pack is panel-mounted and requires a cutout in the mounting surface. Mounting dimensions and terminal designations are shown below.

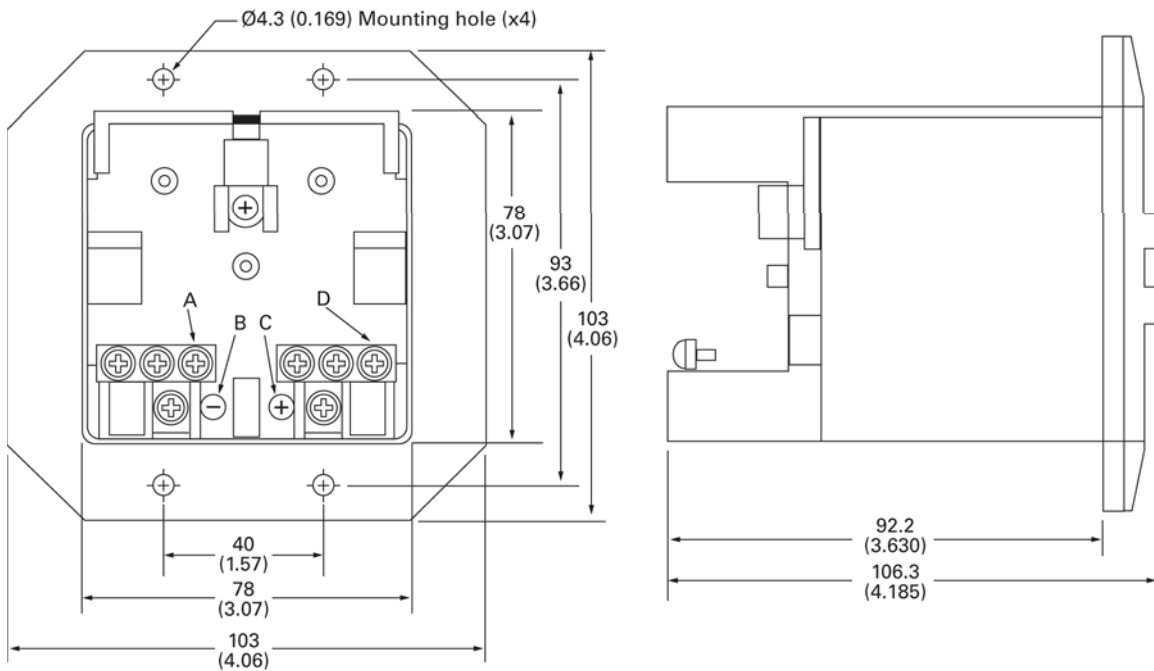

All dimensions in mm (in.)

| | |
|---|---|
| A | 3-M3 negative terminal |
| B | Negative terminal indication |
| C | Positive terminal indication |
| D | 3-M3 positive terminal |
| E | 4- \varnothing 4.3 (0.169) mounting holes |

Figure IV-15. Absolute Encoder Battery Pack IC800ABK001 (up to Four Axes)

Section 29: Installation Guidelines

This section includes environmental requirements, motor and amplifier dimension drawings and information on ensuring noise protection and selecting a ground fault interrupter.

29.1 αi , αHVi and $\alpha HVis$ Motor Environmental Requirements

The servomotor must be installed in a location that satisfies the following environmental conditions:

Table IV-17. Servo Motor Environmental Conditions

| Condition | Description |
|------------------------|--|
| Ambient temperature | 0°C to 40°C When operating the motor at a temperature higher than 40°C, it is necessary to de-rate the output power so that the motor's and the encoder's temperature rating is not exceeded. |
| Ambient humidity | Should be 80% relative humidity or less, non-condensing |
| Vibration | When installed in a machine, the vibration applied to the motor must not exceed 5G. |
| Altitude | Up to 1,000 meters (3,300 ft) above the sea level requires no particular provision for attitude. When operating the machine at a higher level, the maximum operating temperature should be lowered 1°C for every 100m higher than 1,000m. For example, when the machine is installed at 1,500 meters above sea level, the ambient temperature should be 35°C or less. |
| Drip-Proof Environment | The motors have a drip-proof structure that complies with IP65 of the IEC standard. Nevertheless, to ensure long-term performance, the motor surface should be protected from solvents, lubricants, and fluid spray. A cover should be used when there is a possibility of wetting the motor surface. Also, to prevent fluid from being led to the motor through the cable, put a drip loop in the cable when the motor is mounted. Finally, turn the motor connector sideways or downward as far as possible. If the cable connector will be subjected to moisture, it is recommended that an R class or waterproof plug be used. For additional information, see GE Fanuc publication <i>Servo and Spindle Motors Exposed to Liquids</i> , GFK-1046. |

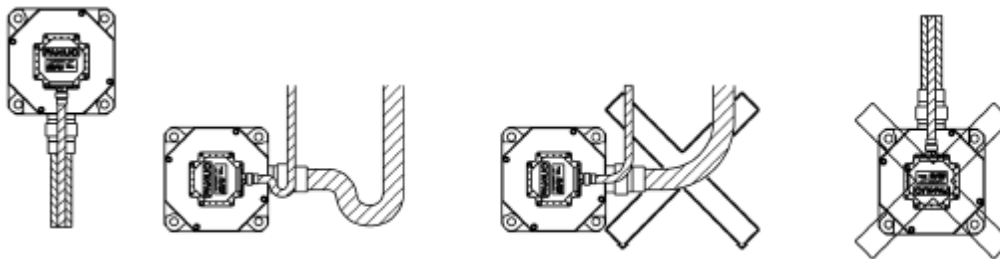

Figure IV-16. Motor Installation for Drip-Proof Environment

29.2 α HVi Servo Amplifier Environmental Requirements

The servo amplifier must be installed in a location that satisfies the environmental conditions identified in the table below.

Table IV-18. Servo Amplifier Environmental Conditions

| <i>Condition</i> | <i>Description</i> |
|-------------------------|---|
| Ambient temperature | Operating: 0°C to 55°C (operating). See temperature derating curves below. Storage and transportation: -20°C to 60°C Outside cabinet: 0°C to 45°C |
| Temperature fluctuation | Within 1.1°C/min. |
| Humidity | 90% relative humidity (non-condensing) or lower. |
| Altitude | No more than 1000 m (3,300 ft) above sea level. |
| Vibration | No more than 0.5 G during operation. |
| Atmosphere | The circuitry and cooling fins must not be exposed to corrosive or conductive vapor or liquid. |

Temperature Derating

Consider derating as shown below, according to ambient operating temperatures. The solid line is a derating line for use when HRV2 is applied. The dotted line is a derating line for use when HRV3 is applied.

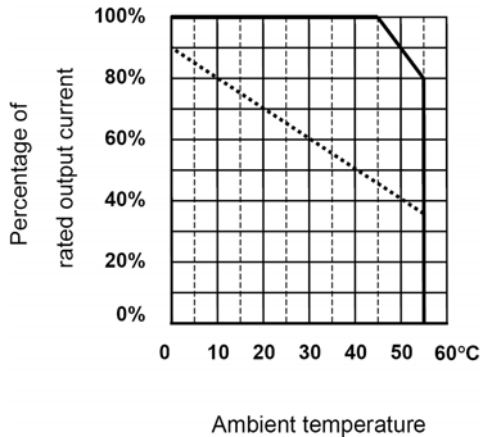

α SVM1-40HVi and α SVM1-80HVi Amplifiers

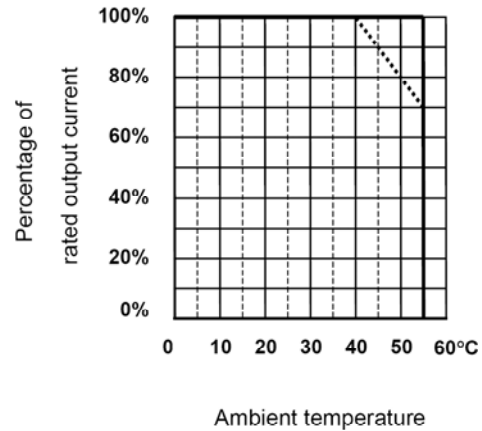

α SVM1-180HVi Amplifiers

Figure IV-17. Temperature Derating

Cabinet Installation

The amplifier must be installed in a cabinet that protects it from contaminants such as dust, coolant, organic solvents, acid, corrosive gas, and salt. Adequate protection must also be provided for applications where the amplifier could be exposed to radiation, such as microwave, ultraviolet, laser light, or x-rays.

To adequately protect the amplifier, you must ensure that:

- Contaminants such as dust and fluid cannot enter through the air inlet or outlet.
- The flow of cooling air is not obstructed.
- The amplifier can be accessed for inspection.
- The amplifier can be disassembled for maintenance and later reinstalled.
- There is sufficient separation between the power and signal lines to avoid interference. Noise protection should be provided.

Note: Attach the accompanying gasket around the panel cutout to prevent oil and dust from getting in. Reinforce the right and left sides of the panel cutout by using fittings such as angles to maintain satisfactory contact between the cabinet and the amplifier.

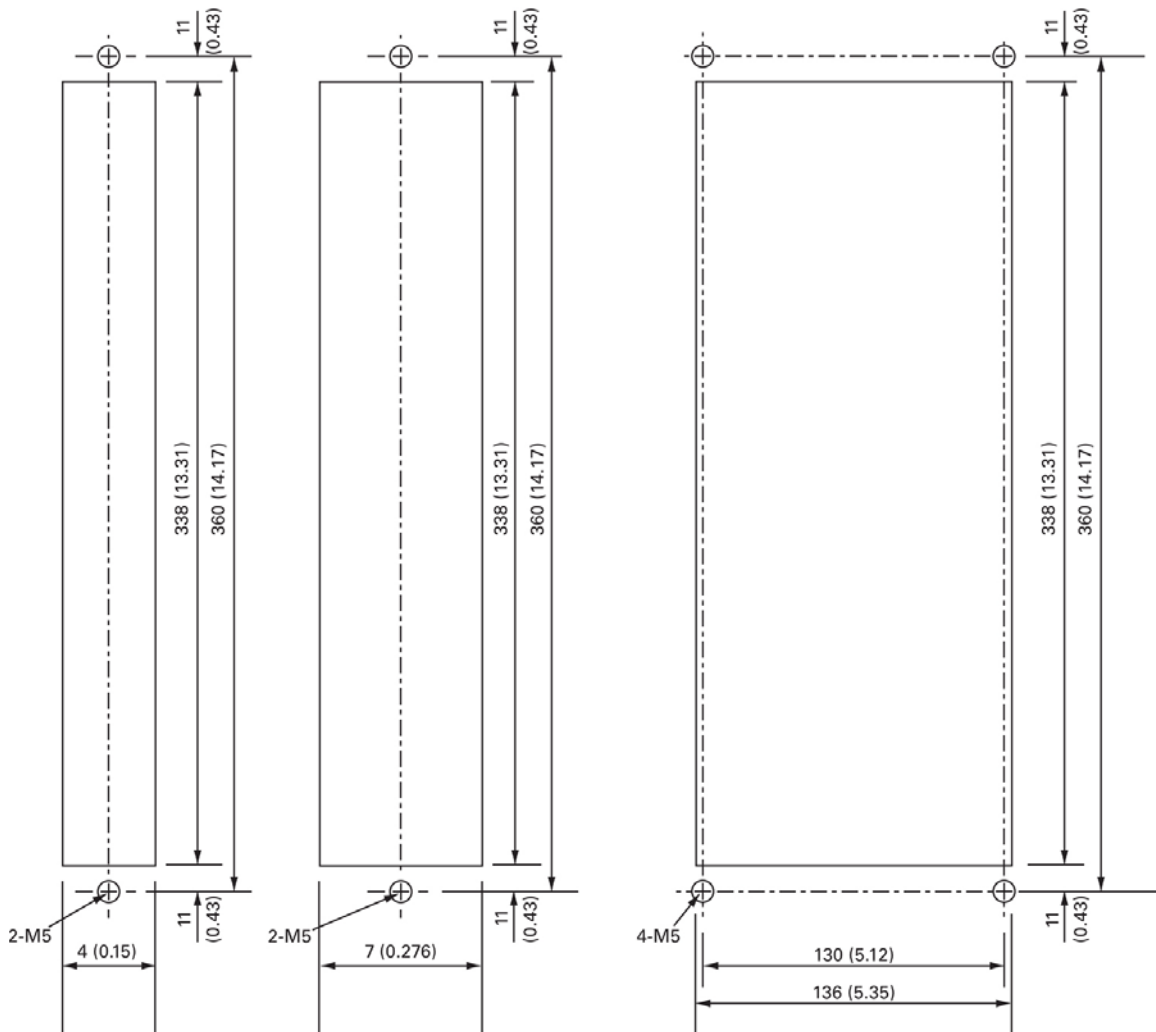
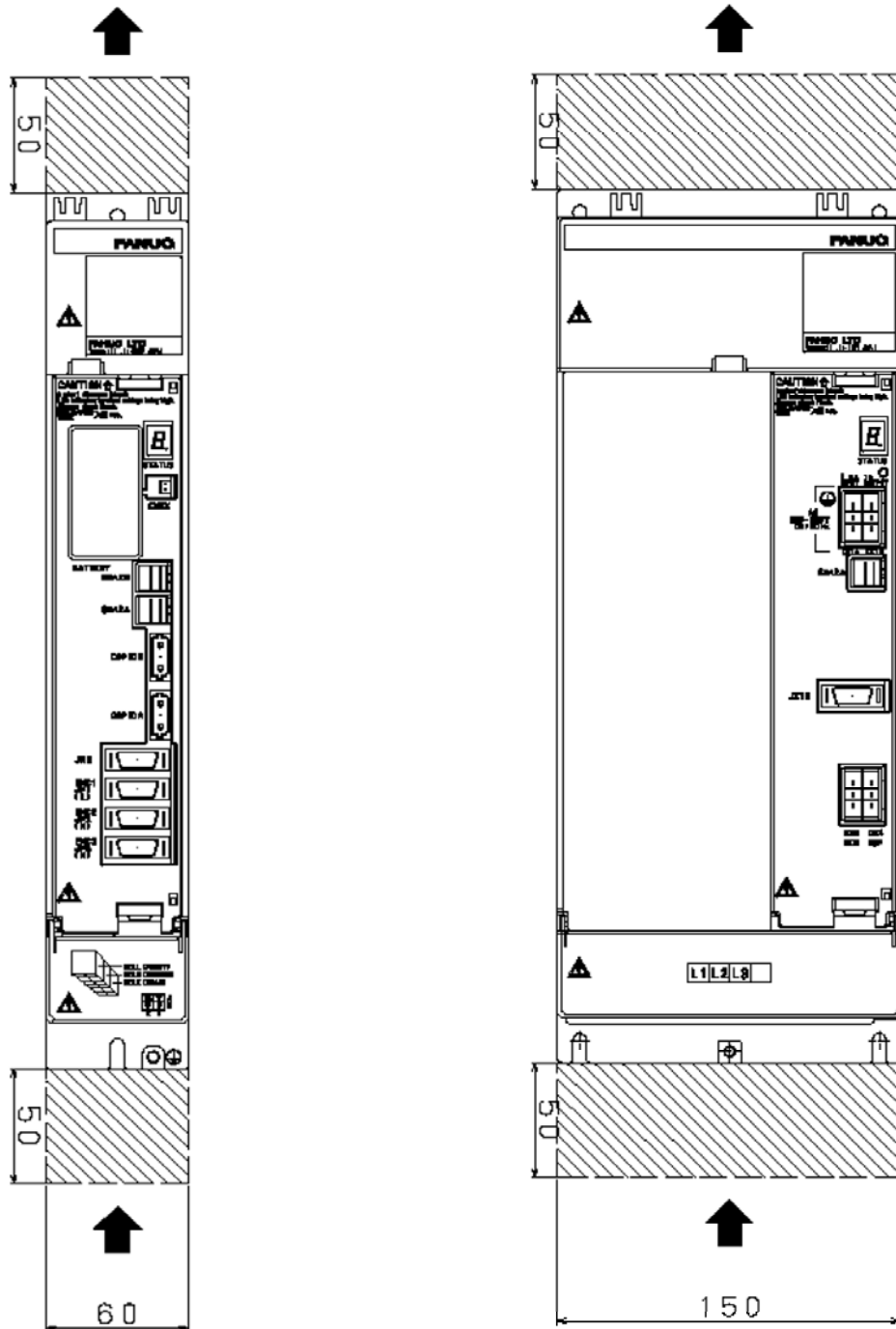

Figure IV-18. Panel Cut-out Drawings for Through-Cabinet Mounting of the αSVM1 Amplifiers

29.3 Amplifier Heat Dissipation and Maintenance Clearance

The amplifier may contain a cooling fan that forces air through the unit. Allow for adequate clearance for airflow when installing the amplifier using the recommended distances shown in the drawings below. If possible, do not mount amplifiers one above the other unless they are staggered to prevent the heated exhaust of the lower unit from flowing over the upper unit.



αSVM1-40HVi and αSVM1-80HVi Amplifiers

αSVM1-180HVi Amplifier

Figure IV-19. αSVM1-80HVi Amplifier Maintenance Clearances (dimensions shown in mm)

Section 30: Heat Dissipation

Table IV-19 identifies worst-case heat dissipation values for each amplifier. These values may be used to determine heat load for sizing enclosures and cooling equipment.

The total heat dissipation is a function of the amplifier base dissipation (a) plus the amplifier heat coefficient (K) times the heat generated by RMS stall current flowing through the servo motor (b).

Total heat dissipation, Watts = a + (K * b)

Table IV-19. In Cabinet Heat Dissipation

| <i>Amplifier</i> | <i>Catalog #</i> | <i>Amplifier base heat dissipation (a)</i> | <i>Amplifier heat coefficient (K)</i> | <i>Motor Model</i> | <i>Motor Current (b) [Arms]</i> | <i>Total heat dissipation [Watts]</i> |
|------------------|------------------|--|---|--------------------|---------------------------------|---------------------------------------|
| αSVM1-40HVi | ZA06B-6124-H104 | 13 watts | 8.8 (heat sink in cabinet) | α12/4000HVis | 6.7 | 71.9 |
| | | | | α22/3000HVis | 9.1 | 93.0 |
| | | | 1.76 (heat sink external to cabinet) | α12/4000HVis | 6.7 | 24.8 |
| | | | | α22/3000HVis | 9.1 | 29.0 |
| αSVM1-80HVi | ZA06B-6124-H105 | 17 watts | 9.0 (heat sink in cabinet) | α22/4000HVis | 15.5 | 156.0 |
| | | | | α30/4000HVis | 15.9 | 160.0 |
| | | | | α40/4000HVis | 18.1 | 180.0 |
| | | | 0.90 (heat sink external to cabinet) | α22/4000HVis | 15.5 | 31.0 |
| | | | | α30/4000HVis | 15.9 | 31.3 |
| | | | | α40/4000HVis | 18.1 | 33.3 |
| αSVM1-180HVi | ZA06B-6124-H106 | 25 watts | 8.8 (heat sink in cabinet) | α50/3000HVis w/Fan | 39.6 | 373.0 |
| | | | 0.44 (heat sink external to cabinet) | α50/3000HVis w/Fan | 39.6 | 42.4 |

Section 31: Noise Protection

31.1 Grounding

A typical machine has three separate grounds:

- **Signal Ground:** Provides the reference potential (0 V) for the electrical signal system.
- **Frame Ground:** Ensures safety and shields external and internal noise.
- **System Ground:** Connects each unit and the inter-unit frame ground system to earth ground.

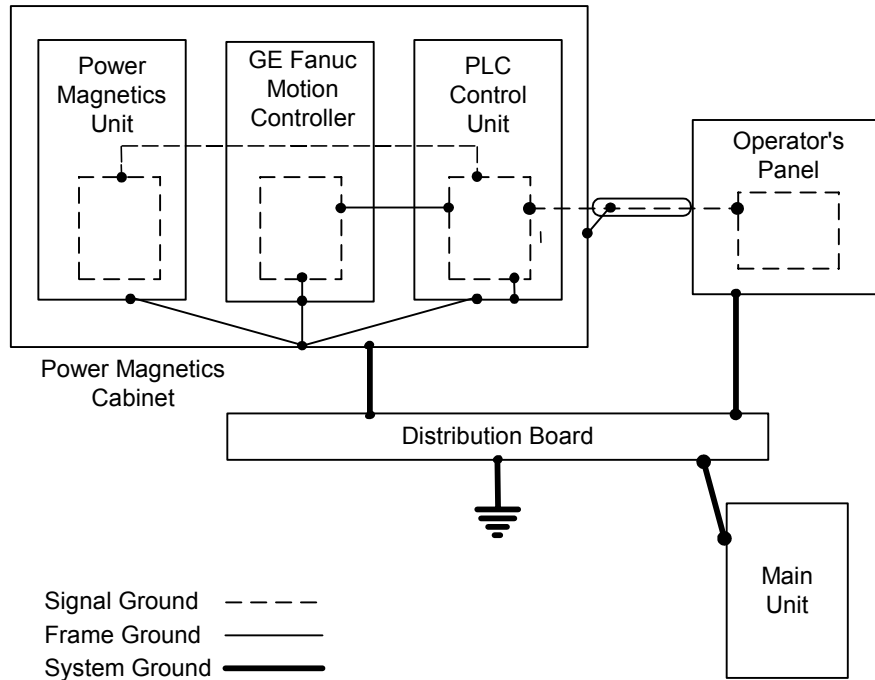

Figure IV-20. Ground System

Ground system wiring:

- Connect the signal ground (0V) with the frame ground (FG) at only one place in the power supply module.
- The grounding resistance of the system ground shall be 100 ohms or less (class D grounding).
- The system ground cable must have enough cross-sectional area to safely carry the accidental current flow into the system ground when an accident such as a short circuit occurs. (Generally, it must have the cross-sectional area of the AC power cable or more.)
- Use the cable containing the AC power wire and the system ground wire so that power is supplied with the ground wire connected.

Servo Products Specification Guide

Grounding of Each Module

- Separate the frame ground (FG) of the power system and that of the signal system. Otherwise, noise may propagate from the power system to the signal system, possibly causing the unit to malfunction.
- Connect the ground terminal of the Power Supply's CX1A connector to the frame ground. This acts as the signal ground. Connect the ground terminal of the metal frame to the frame ground.
- Connect the ground cable of the motor power cable to a ground terminal of the Servo Amplifier's terminal block. Connect the other ground terminal of the terminal block to the frame ground. Connect the ground terminal of the metal frame to the frame ground.
- On the Regenerative Discharge Unit and Dynamic Brake Module, connect the ground terminal of the metal frame to the frame ground.

Note:

- Securing the ground terminal and a cable together is not permitted.
- The motor flange mounting section may not be able to be connected to the machine mounting section of the power magnetics cabinet via the mechanical unit at sufficiently low impedance in a machine. In this case, a cable of a minimum required length that is at least 1.25 mm² thick must be run from the motor flange to the frame ground of the power magnetics cabinet. The cable must also be separated from the motor power line as much as possible.

31.2 Separation of Signal and Power Lines

When routing signal and power lines, the signal lines must be separated from the power lines to ensure best noise immunity. The table below lists the types of cables used:

Table IV-20. Servo amplifier signal line separation

| Group | Signal Type | Action |
|-------|--|--|
| A | Amplifier input power line Motor power line Magnetic contactor drive coil ¹ | Separate these cables from those of group B by bundling them separately ² or by means of electromagnetic shielding ³ . Attach a noise suppressor (spark arrester) to the MCC drive coil. |
| B | Cable connecting control unit with servo amplifier Serial encoder feedback cable | Separate these cables from those of group A by bundling them separately* or by means of electromagnetic shielding**. In addition, shielding must be provided. |

¹ Attach a noise suppressor such as a spark killer to the magnetic contactor drive coil.

² The bundle of group A cables must be separated from the bundle of group B cables by at least 10 cm.

³ Electromagnetic shielding involves shielding groups from each other by means of a grounded metal (steel) plate.

31.3 Cable Clamp and Shield Grounding

Terminal processing of the shield sheaths

Perform terminal processing of the shield sheaths of the signal cables according to the description in “aHVi Series Servo System Connection” on page IV-46.

Cable clamp

The cables that run into the amplifier and which require shield processing must be clamped as indicated in Fig. 5.3.2(a).

Clamping secures a cable and also provides shielding. Clamping must always be performed since it is very important for stable system operation.

Strip part of the cable jacket to expose the shield sheath, as shown in the figure below. Secure that part of the cable to the ground plate by using a clamp. At this time, the ground plate must be in contact with the surface of the shield so that the contact area becomes wide.

Connect each shield cable to the ground plate installed near the cabinet inlet by using a ground clamp. This prevents noise generated in the panel from being emitted to external devices.

Connect the cable clamp of the signal cables of SVM connected to common PSM to common the ground plate for signals.

Grounding

The ground plate must be created and installed by the user as shown in Figure IV-21.

31.4 Encoder Feedback Cable Grounding

The motor encoder feedback cable shielding should be grounded by the method shown below. This cable clamp treatment provides both cable support (strain relief) and proper grounding of the shield. To ensure stable system operation, the cable clamp method is recommended. Partially peel back the cable sheath to expose the shield. Push the clamp (ZA99L-0035-0001) over the exposed shield and insert the clamp hooks into slots on the grounding bar (Z44B295864-001). Tighten the clamp to secure cable and complete the ground connection. The grounding bar must be attached to a low impedance earth ground.

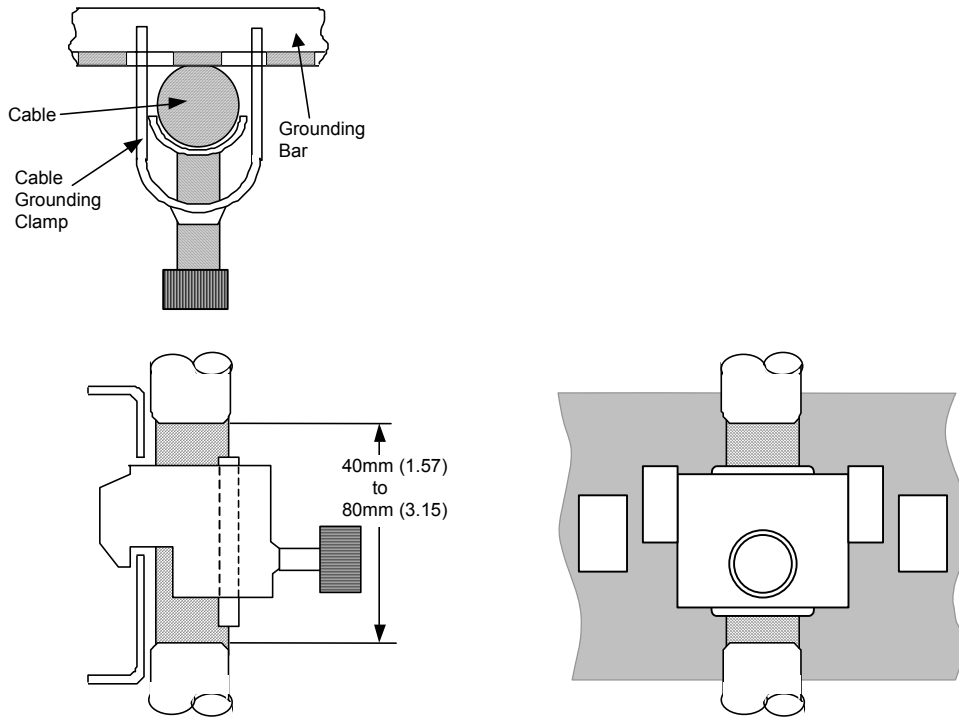

Figure IV-21. Cable Grounding Clamp Detail

Note: The grounding bar should be located as close as possible to the amplifier to minimize cable length between amplifier and grounding bar. Observe recommended maintenance clearance.

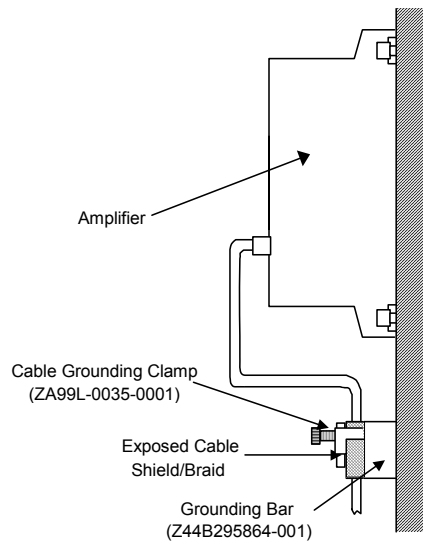

Figure IV-22. Feedback Cable Shield Grounding System

Servo Products Specification Guide

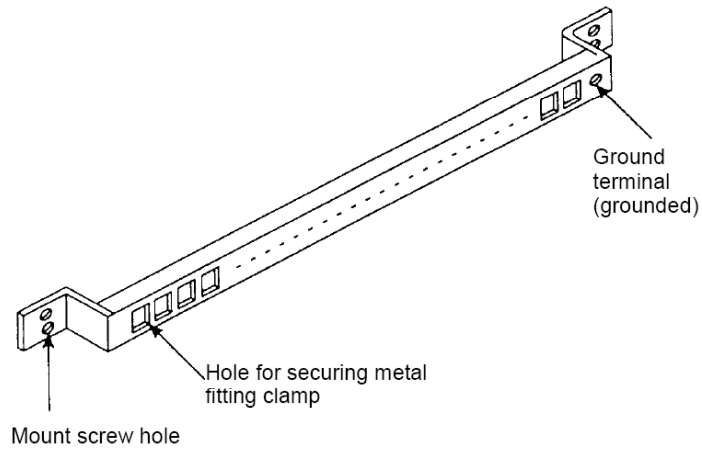

Figure IV-23. Ground Plate

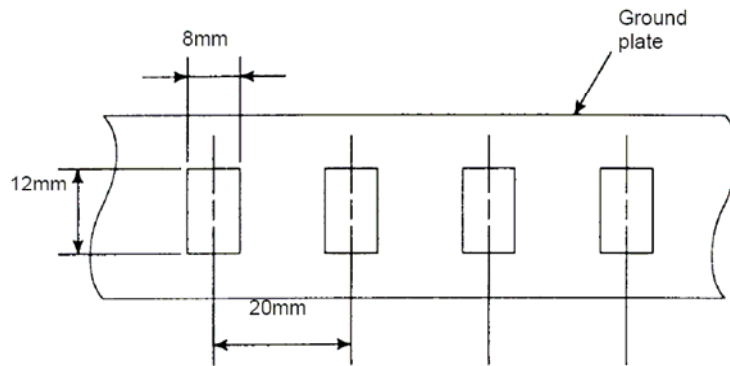

Figure IV-24. Ground Plate Holes

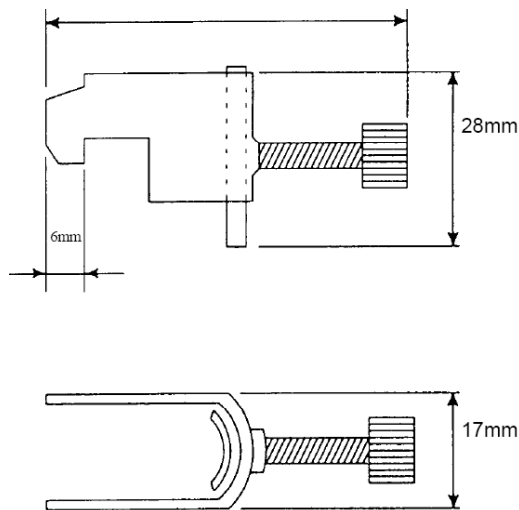

Figure IV-25. Metal Fittings for Clamp

Section 32: α HVi Servo System Power Requirements

This section provides information about AC and DC amplifier power as well as the discharge of regenerative power.

32.1 Power Line Protection

A circuit breaker, electromagnetic contactor, and AC line filter or transformer should be installed as part of your α HVi Series Servo system. GE Fanuc provides the AC line filter as an option. The transformer, circuit breaker, and electromagnetic contactor, however, are user-supplied components. In European countries where power sources are 380 to 400 VAC and neutral grounded, it is necessary to install a transformer or supply single-phase power for the α i Series amplifiers.

The same incoming AC control components can be used to provide power to multiple amplifiers, as long as the components are rated for the current and power drawn by the sum of all of the amplifiers.

32.2 AC Line Filter

An AC line filter is recommended to suppress the influences of high-frequency input line noise on the drive power supply. When an isolation-type power transformer is used because a power supply voltage within the specified range is not available, an AC line filter is not required.

If two or more servo amplifiers are connected to one AC line filter, the total continuous output rating of all connected servo amplifiers should be kept below the continuous output rating of the AC line filter. The continuous output rating for the various servos are shown below.

Table IV-21. α i Servo Motor Continuous Output Rating at Low Line of 200 VAC

| <i>Motor</i> | <i>Continuous Output Rating</i> |
|-------------------|---------------------------------|
| α 22/3000i | 4.0 KW |

Table IV-22. α HVis Servo Motor Continuous Output Rating at Low Line of 400 VAC

| <i>Motor</i> | <i>Continuous Output Rating</i> |
|-------------------------------|---------------------------------|
| α 12/4000HVis | 2.5 KW |
| α 22/3000HVi | 4.0 KW |
| α 22/4000HVis | 4.5 KW |
| α 30/4000HVis | 5.5 KW |
| α 40/4000HVis | 5.5 KW |
| α 50/3000HVis with fan | 14 KW |

If your installation must be EMC compliant, verify that the use of an AC line filter fully satisfies the EMC requirements. You may need to select and install a user-supplied noise filter to meet EMC requirements.

AC Line Filter Outline Drawings and Specifications

AC line filters are available for GE Fanuc servo amplifiers:

| Dim. | AC Line Filter | |
|------|---|---|
| | ZA81L-0001-0163 for PSM-11HVi and PSM-18HVi | ZA81L-0001-0164 for PSM-30HVi and PSM-45HVi |
| A | 135 | 185 |
| B | 155 | 172 |
| C | 165 | 175 |
| D | 55 | 70 |
| E | 145 | 154 |
| F | 84 | 116 |
| G | 66 | 106 |
| H | 135 | 185 |
| K | 7 | 7 |
| M | M5 | M8 |

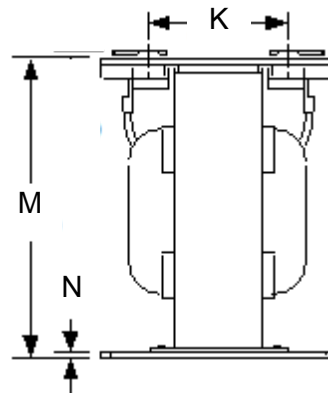
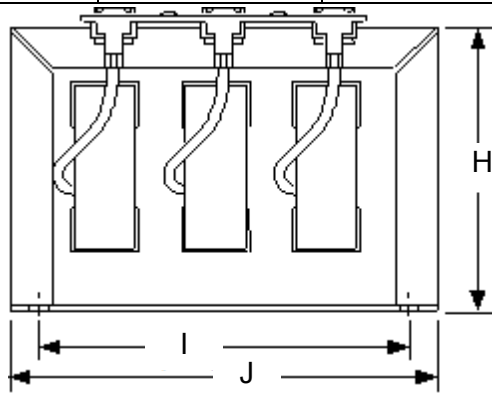
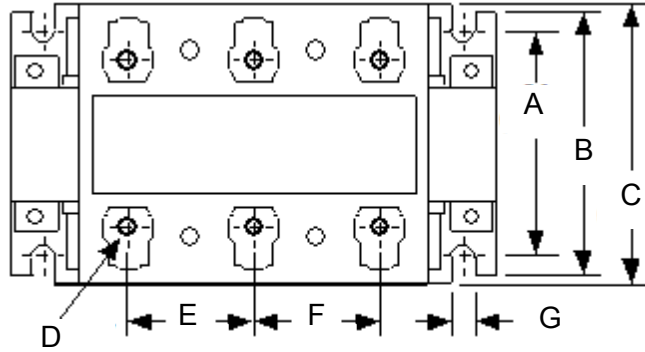

Figure IV-26. AC Line Filter Outline Drawing

32.3 Circuit Breaker and Magnetic Contactor Selection

To provide proper protection for the amplifier, use a circuit breaker rated at no more than 20 Amps (10A for VDE 1601 compliance for CE marking). Table IV-23 will help you select the appropriate circuit breaker for your motion application.

To prepare for incoming AC power, you must also select and install an appropriate electromagnetic contactor, based on the peak currents for the motors in your system. When multiple amplifiers are connected to a single circuit breaker, select a breaker based on the sum of the motor currents in Table IV-23.

Table IV-23. Circuit Breaker and Magnetic Contactor Specification

| <i>Power Supply</i> | <i>Circuit Breaker 1</i> | <i>Circuit Breaker 2</i> | <i>Circuit Breaker 3</i> | <i>Magnetic Contactor</i> |
|---------------------|--------------------------|--------------------------|--------------------------|---------------------------|
| PSM-11HVi | 20A | 3A | 3A | 20A |
| PSM-18HVi | 45A | | | 45A |
| PSM-30HVi | 75A | | | 75A |
| PSM-45HVi | 125A | | | 125A |

Notes:

- For the installation positions of the circuit breakers and magnetic contactor, see the sample configurations on pages IV-43 and IV-44.
- Set the rated voltage of circuit breakers 1 and 2 according to the power supply voltage.
- The current and voltage of the operation coil of the magnetic contactor must be within the rating of the internal contact CX3 (MCC) of the Power Supply. For details, see “Details of Cable K1” on page IV-61.

Sample Configuration for 200V Input Power

Notes:

- A magnetic contactor, AC line filter, and circuit breakers are always required.
- To protect the unit from surge currents caused by lightning, connect surge absorbers between lines, and between the lines and ground, at the power inlet of the power magnetic cabinet.

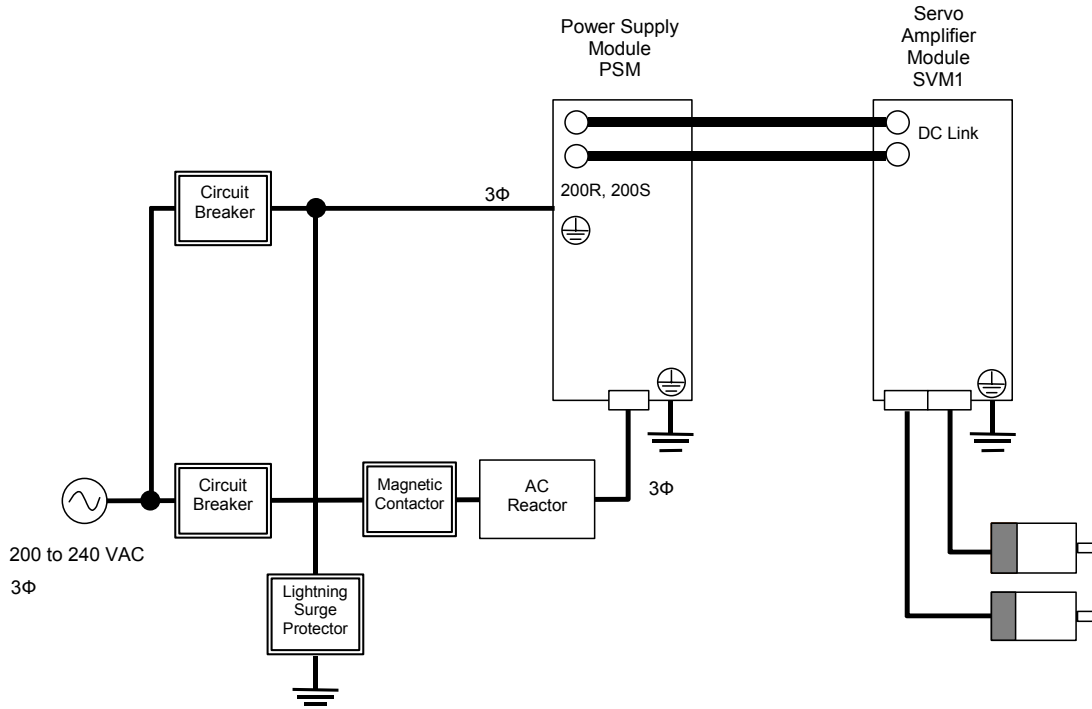

Sample Configuration for 400V Input Power

Notes:

- Single-phase 200VAC is required for the control power supply.
- A magnetic contactor, AC line filter, and circuit breakers are always required.
- To protect the unit from surge currents caused by lightning, connect surge absorbers between lines, and between the lines and ground, at the power inlet of the power magnetic cabinet.
- Measures must be taken to detect the operation (trip) of circuit breaker 3.

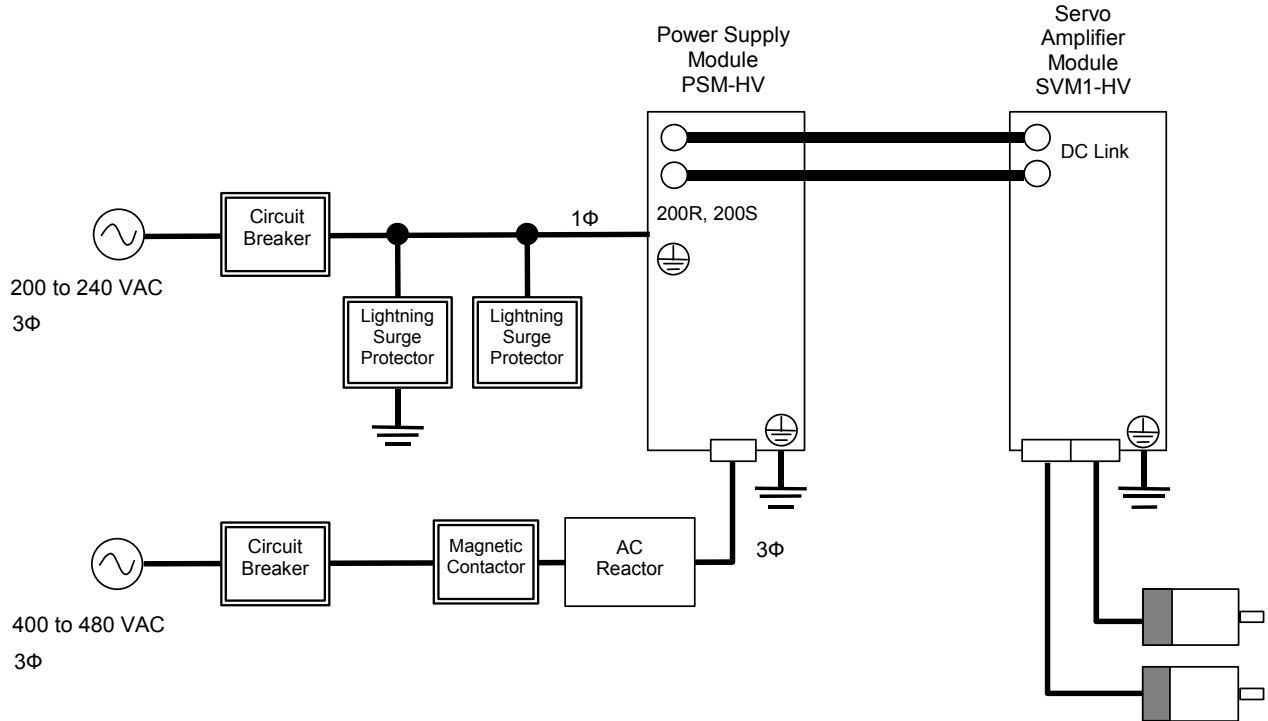

32.4 Incoming AC power

Table IV-24. AC Power

| <i>Specification</i> | <i>αHVi Amplifiers</i> |
|---|---|
| Voltage for the main circuit: 3-phase (+10%, -15%) 1-phase (+10%, -15%) | 400—480 VAC n/a |
| Power supply voltage for the control circuit | Single-phase 200 VAC to 240 VAC (input from connector CX1A) |
| Allowable voltage deviation | -15% to =10% (including voltage variation due to load) |
| Frequency | 50 Hz/60Hz, ±1 Hz |
| Power supply unbalance | ±5% of the rated voltage or less |
| Power supply impedance Note: When the power supply impedance is high, and the voltage variation exceeds the specified values, a PSM alarm (DC link undervoltage alarm or DC link overvoltage alarm) can be issued, or the output of the motor can decrease. | The voltage variation must be within ±7% when a maximum output is produced for voltage at non-load time (power running and regeneration). |

AC Power Ratings

The power supply rating required when using multiple servo motors can be determined by summing the requirements of the individual motors.

The power supply ratings listed in Table IV-25 are sufficient as continuous ratings. Note, however, that servo motor acceleration causes a current to momentarily flow that is approximately three times the continuous current rating.

When the power is turned on, a surge current of about 37A (when 264VAC is applied) flows for 20 msec.

Table IV-25. Three-Phase Power Supply Ratings

| <i>Motor</i> | <i>Continuous Output Rating</i> |
|--------------------------|---------------------------------|
| α22/3000is | 4.0 KW |
| α12/4000HVis | 2.5 KW |
| α22/3000HVis | 4.0 KW |
| α22/4000HVis | 4.5 KW |
| α30/4000HVis | 5.5 KW |
| α40/4000HVis | 5.5 KW |
| α50/3000HVis with fan | 14 KW |

Section 33: α HVi Series Servo System Connection

When planning your motion control system, it is important to determine how the different parts of the system connect together. This section provides information on the various cables and connectors required to connect the motor, amplifier and motion controller.

Many cables required for the system are available from GE Fanuc. Motor cable and connector kit part numbers for each motor and amplifier combination are shown in the tables below.

Table IV-26. α 12HVis and α 22HVis Motor Power, Feedback and Brake Cables and Connector Kits

| <i>Motor Model</i> | | <i>α12/4000HVis</i> | <i>α22/3000HVi</i> | <i>α22/4000HVis</i> |
|---|------|---------------------------------------|--------------------------------------|---------------------------------------|
| <i>Amplifier Model</i> | | <i>αSVM1-40HVi</i> | <i>αSVM1-40HVi</i> | <i>αSVM1-80HVi</i> |
| Motor Feedback Cable (90° Connector) | 7m | CFDA-3WPB-0070-AZ | CFDA-3WPB-0070-AZ | CFDA-3WPB-0070-AZ |
| | 14m | CFDA-3WPB-0140-AZ | CFDA-3WPB-0140-AZ | CFDA-3WPB-0140-AZ |
| Motor Feedback Cable (Straight Connector) | 7m | CFDA-0WPB-0070-AZ | CFDA-0WPB-0070-AZ | CFDA-0WPB-0070-AZ |
| | 14m | CFDA-0WPB-0140-AZ | CFDA-0WPB-0140-AZ | CFDA-0WPB-0140-AZ |
| Motor Power Cable | 7m | CP3I-0WPB-0070-AZ | CP4I-0WPB-0070-AZ | CP4I-0WPB-0070-AZ |
| | 14m | CP3I-0WPB-0140-AZ | CP4I-0WPB-0140-AZ | CP4I-0WPB-0140-AZ |
| Motor Brake Power Cable | 7m | CB4N-0WPM-0070-AZ | CB4N-0WPM-0070-AZ | CB4N-0WPM-0070-AZ |
| | 14m | CB4N-0WPM-0140-AZ | CB4N-0WPM-0140-AZ | CB4N-0WPM-0140-AZ |
| Motor Power Cable, Shielded | 7m | CP4I-0WEB-0070-AZ | CP4I-0WEB-0070-AZ | CP4I-0WEB-0070-AZ |
| | 14m | CP4I-0WEB-0140-AZ | CP4I-0WEB-0140-AZ | CP4I-0WEB-0140-AZ |
| PSM Interface Cable (panel mounted battery) | 0.2m | Z44C746453-001 | Z44C746453-001 | Z44C746453-001 |
| PSM Interface Cable (Built-in Lithium Battery or No battery) | 0.2m | Z44C746453-002 | Z44C746453-002 | Z44C746453-002 |
| PSM Power Supply Module Connector Kit | NA | ZA06B-6071-K203 | ZA06B-6071-K203 | ZA06B-6071-K203 |
| Amplifier CXA2A/B Connector | NA | ZA06B-6110-K210 | ZA06B-6110-K210 | ZA06B-6110-K210 |

Servo Products Specification Guide

Table IV-27. α 30HVis to α 50HVis Motor Power, Feedback and Brake Cables and Connector Kits

| <i>Motor Model</i> | | <i>α30/4000HVis</i> | <i>α40/4000HVis</i> | <i>α50/3000HVis with fan</i> |
|--|-----|---------------------------------------|---------------------------------------|--|
| <i>Amplifier Model</i> | | <i>αSVM1-80HVi</i> | <i>αSVM1-180HVi</i> | <i>αSVM1-180HVi</i> |
| Motor Feedback Cable (90° Connector) | 7m | CFDA-3WPB-0070-AZ | CFDA-3WPB-0070-AZ | CFDA-3WPB-0070-AZ |
| | 14m | CFDA-3WPB-0140-AZ | CFDA-3WPB-0140-AZ | CFDA-3WPB-0140-AZ |
| Motor Feedback Cable (Straight Connector) | 7m | CFDA-0WPB-0070-AZ | CFDA-0WPB-0070-AZ | CFDA-0WPB-0070-AZ |
| | 14m | CFDA-0WPB-0140-AZ | CFDA-0WPB-0140-AZ | CFDA-0WPB-0140-AZ |
| Motor Power Cable | 7m | CP4I-0WPB-0070-A | CP4I-0WPB-0070-A | CP9I-0MPB-0070-AZ |
| | 14m | CP4I-0WPB-0140-A | CP4I-0WPB-0140-A | CP9I-0MPB-0140-AZ |
| Motor Power Cable, Shielded | 7m | CP4I-0WEB-0070-AZ | CP4I-0WEB-0070-AZ | CP9I-0MEB-0070-AZ |
| | 14m | CP4I-0WEB-0140-AZ | CP4I-0WEB-0140-AZ | CP9I-0MEB-0140-AZ |
| Motor Brake Power Cable | 7m | CB4N-0WPM-0070-AZ | CB4N-0WPM-0070-AZ | CB4N-0WPM-0070-AZ |
| | 14m | CB4N-0WPM-0140-AZ | CB4N-0WPM-0140-AZ | CB4N-0WPM-0140-AZ |
| Motor Fan Power Cable | 7m | NA | NA | CB5N-0WPM-0070-AZ |
| | 14m | NA | NA | CB5N-0WPM-0140-AZ |
| PSM Interface Cable (panel mounted battery) | 2m | Z44C746453-001 | Z44C746453-001 | Z44C746453-001 |
| PSM Interface Cable (Built-in Lithium Battery or No battery) | 2m | Z44C746453-002 | Z44C746453-002 | Z44C746453-002 |
| PSM Power Supply Module Connector Kit | NA | ZA06B-6071-K203 | ZA06B-6071-K203 | ZA06B-6071-K203 |
| Amplifier CXA2A/B Connector | NA | ZA06B-6110-K210 | ZA06B-6110-K210 | ZA06B-6110-K210 |
| CX8/CX9 Dynamic Brake Module Interface Connector Kit | NA | NA | NA | ZA06B-6073-K216 |
| CX1A/B Dynamic Brake Module Control Power Connector Kit | NA | NA | NA | ZA02B-0120-K321 |

33.1 Motor Power Connectors

For the Servo Motor αi , αHVi and $\alpha HVis$ series, connect the power line of the motor and the signal line of an absolute encoder to an $\alpha SVM1$ Servo Amplifier. When the motor has a built-in brake or cooling fan as an option, connect the built-in brake or cooling fan to the specified power supply.

Table IV-28. Connectors for αi , αHVi and $\alpha HVis$ Motors

| <i>Motor Type</i> | <i>for Power</i> |
|----------------------------------|--------------------------|
| $\alpha 12/4000HVis$ | 90°: Z44A730464-G18 |
| | Straight: Z44A730464-G17 |
| $\alpha 22/3000i$ | 90°: Z44A730464-G20 |
| | Straight: Z44A730464-G19 |
| $\alpha 22/3000HVi$ | 90°: Z44A730464-G20 |
| | Straight: Z44A730464-G19 |
| $\alpha 22/4000HVis$ | 90°: Z44A730464-G20 |
| | Straight: Z44A730464-G19 |
| $\alpha 30/4000HVis$ | 90°: Z44A730464-G20 |
| | Straight: Z44A730464-G19 |
| $\alpha 40/4000HVis$ | 90°: Z44A730464-G20 |
| | Straight: Z44A730464-G19 |
| $\alpha 50/3000HVis$ with fan | 90°: Z44A730464-G20 |
| | Straight: Z44A730464-G19 |

CAUTION

Motors should be installed with their connector facing downward if possible. When it is impossible to install a motor in this position, allow slack in the cable to keep liquids such as a dielectric fluid from flowing along the cable into the cable capacitor or motor. If there is a possibility that the motors and connectors will get wet, provide a cover to protect them.

If a motor is not connected to the earth ground through the machine (frame), connect the motor grounding point and the amplifier grounding point to absorb noise using a 1.25 mm² or larger conductor other than the grounding conductor in the power cable. Keep the grounding conductor as far from the power cable as possible.

33.2 Encoder Connectors for ai, aHVi and aHVIs Motors

For all servo motors of the ai series, a small dedicated connector is used for the Encoder signals. The connector is drip-proof when engaged with the motor connector.

There are two types of connectors depending on how a cable is connected to a connector: the crimp type and the solder type. For the crimp type connector, a dedicated crimping tool is required.

The diameter of the cable used is restricted considering cable clamp and voltage drop. The connectors for signals do not have to conform to IEC60034.

Crimp Type Connector

| Connector Specifications | | For Signal | |
|-------------------------------|---------|--|--|
| Straight Type | | JN2DS10SL1-R or JN2DS10SL2-R: Connector JN1-22-22S: Contact (Japan Aviation Electronics Industry) Connector ZA06B-6114-K204#S (FANUC specification)* Including the contact | |
| Right Angle Type | | JN2FS10SL1-R or JN2FS10SL2-R: Connector JN1-22-22S: Contact (Japan Aviation Electronics Industry) ZA06B-6114-K204#E (FANUC specification)* Including the contact | |
| Insulation external diameter | | Φ1.5 or less | |
| Compatible cable O.D. | | Φ5.7 to Φ7.3: JN2DS10SL1-R or JN2FS10SL1-R Φ6.5 to Φ8.0: JN2DS10SL2-R or JN2FS10SL2-R *With the FANUC specifications, two types of bushings: for Φ5.7 to Φ7.3 and for Φ6.5 to Φ8.0 are included. | |
| Wire | | Cable length: 28m or less | Cable length: 50m or less |
| | 5V, 0V | 0.3 mm ² x 2 | 0.5mm ² x 2 *Use a cable with strand configuration 20/0.18 or 104/0.08. |
| | 6V | 0.3 mm ² x 2 | 0.5mm ² *Use a cable with strand configuration 20/0.18 or 104/0.08. |
| | RD, *RD | Twisted pair of at least 0.18 mm ² | |
| Tool for crimping terminal | | AWG#21 (0.5mm ² :20/0.18) | CT150-2-JN1-E (Japan Aviation Electronics Industry) A06B-6114-K201#JN1E (FANUC specification) |
| | | AWG#23 (0.3mm ²) | |
| | | AWG#25 (0.18mm ²) | |
| | | AWG#20 (0.5mm ² :104/0.08) | CT150-2-JN1-D (Japan Aviation Electronics Industry) A06B-6114-K201#JN1D (FANUC specification) |
| | | AWG#21 (0.5mm ² :20/0.18) | |
| | | AWG#25 (0.18mm ²) | |
| Tool for pulling terminal out | | ET-JN1(Japan Aviation Electronics Industry) A06B-6114-K201#JN1R (FANUC specification) | |

Servo Products Specification Guide

The outside dimensions of each type of connector when engaged are shown below:

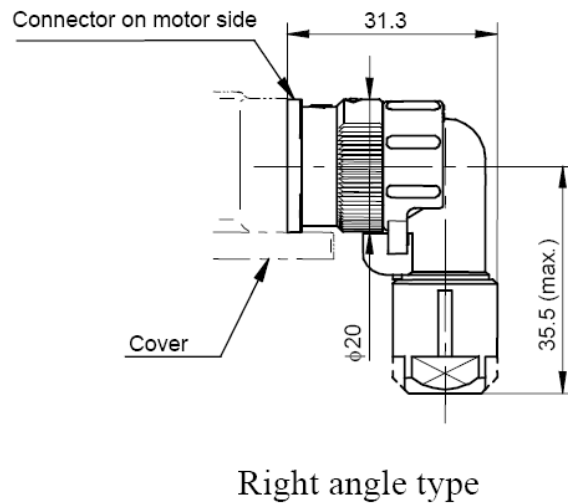
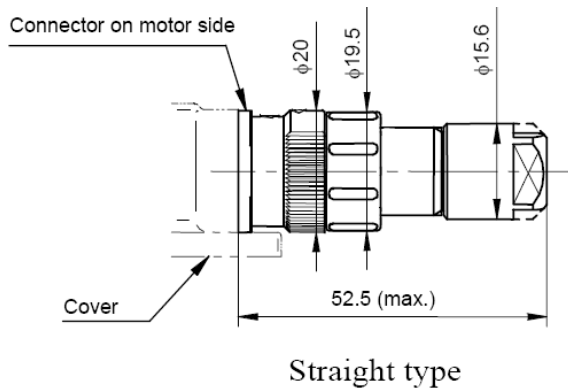

Solder Type Connector

| Connector specifications | | For Signal | |
|--------------------------|---------|---|----------------------------|
| Straight type | | HR34B-12WPA-10S or HR34B-12WPB-10S (Hirose Electric) ZA06B-6114-K205#S (FANUC specification) | |
| Right angle type | | HR34B-12WLPA-10S or HR34B-12WLPB-10S (Hirose Electric) ZA06B-6114-K205#E (FANUC specification) | |
| Applicable wire size | | AWG#20 or less (φ0.8mm or less) | |
| Compatible cable O.D. | | φ5.7 to φ7.3: HR34B-12WPA-10S or HR34B-12WLPA-10S φ6.5 to φ8.0: HR34B-12WPB-10S or HR34B-12WLPB-10S *FANUC specification includes two types of bushings and end nuts for φ5.7 to φ7.3 and for φ6.5 to φ8.0. | |
| Wire | | Cable length: 28 m or less | Cable length: 50 m or less |
| | 5V,0V | 0.3 mm ² × 2 | 0.5 mm ² × 2 |
| | 6V | 0.3 mm ² | 0.5mm ² |
| | RD, *RD | Twisted pair of at least 0.18 mm ² | |

The outside dimensions of each type of connector when engaged are shown below:

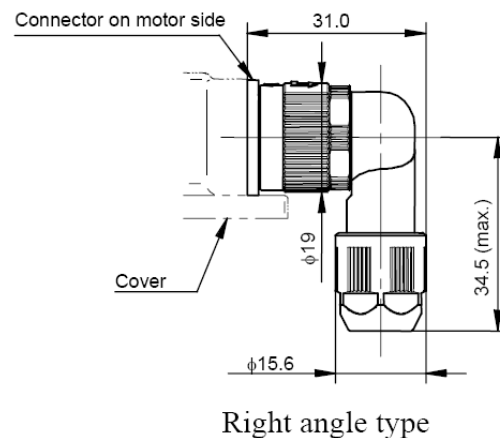
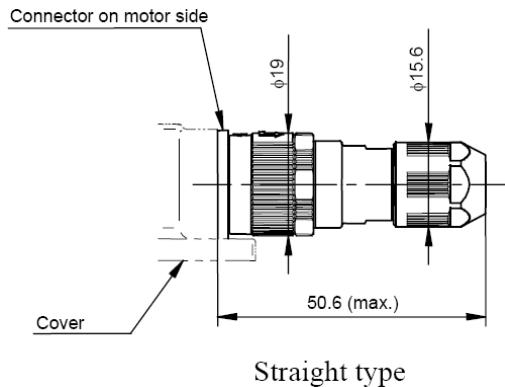

33.3 Connectors for Power

To meet the IEC60034 standard, TUV-approved plug connectors and cable clamps should be used to connect the power cable. To meet the IEC60034 standard by using a cable or conduit hose seal adapter, contact the manufacturer for details. GE Fanuc can provide TUV-approved types (waterproof) and waterproof types as plug connectors on the cable side for the GE Fanuc *ai* series AC servo motors. All these connectors are black. Of course, conventional plug connectors may be used, because they are MS-compatible. The specifications of each connector are explained based on the examples shown below.

The specification numbers used for ordering a power connector kit from GE Fanuc are listed below. The power connector kit contains a plug connector on the cable side (waterproof conforming to IP67, TUV approved type) described subsequently.

| Motors | Power connector kit specification | Content |
|--|--|--|
| α12/4000HVis | Z44A730464-G17 | Straight type connector + cable clamp |
| | Z44A730464-G18 | Right angle type connector + cable clamp |
| α22/3000i, α22/3000HVi α22/4000HVis, α30/4000HVis α40/4000HVis, and α50/3000HVis with fan | Z44A730464-G19 | Straight type connector + cable clamp |
| | Z44A730464-G20 | Right angle type connector + cable clamp |

Connector Connection Example

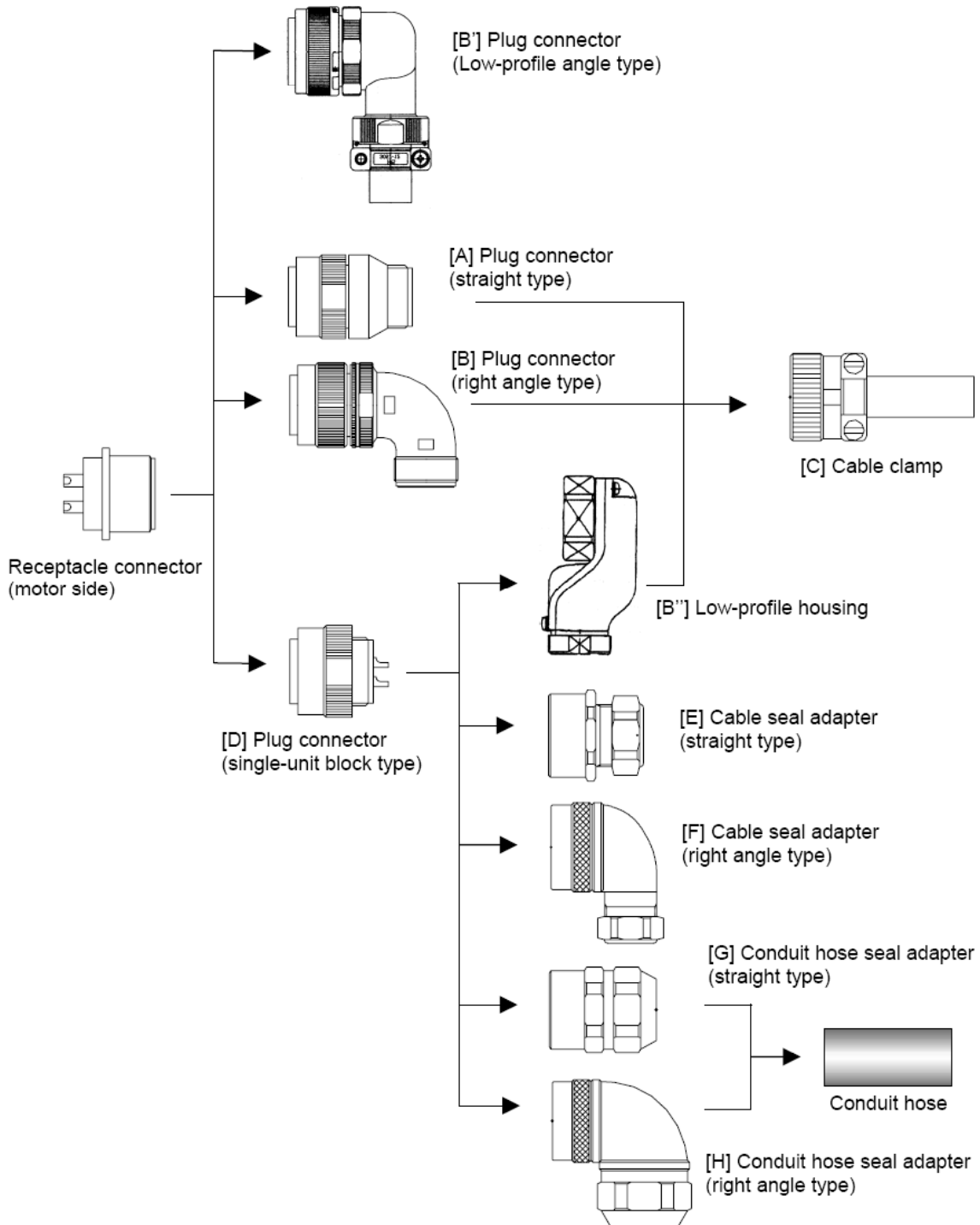

Servo Products Specification Guide

Motor Power Connectors (support for waterproof IP67, TUV-approved type)

Listed below are the manufacturer's part numbers for waterproof (conforming to IP67), TUV-approved motor power connectors supplied by the manufacturers listed. For details of the connectors, contact each manufacturer.

| Motor | [D] Single Block Type Plug Connector | [A] Straight Type Plug Connector | [B] Right angle Type Plug Connector | [B'] Low profile angle type plug connector (with clamp) | [B''] Low profile housing | [C] Cable Clamp |
|--|---|---|---|--|---|--|
| α12/4000HVis | Hirose Electric | | | | | |
| | H/MS3106A 18-10S-D-T(13) | H/MS3106A 18-10S-D-T(10) | H/MS3108A 18-10S-D-T(10) | (1) H/MS3108A 18-10S- DT10D(10) (2) H/MS3108A 18-10S- DT10D1(10) | - | H/MS3057-10A (10) |
| | Solder pot diameter φ2.6 | | | Solder pot diameter φ2.5 Compatible cable O.D. (1) φ2 - φ14.3 (2) φ10 - φ12.5 | - | Compatible cable O.D. φ10.3 - φ14.3 |
| α22/3000i, α22/3000HV α22/4000HV α30/4000HV α40/4000HV α50/3000HV with fan | Japan Aviation Electronics Industry | | | | | |
| | JL04V-6A22- 22SE-R Both (1) and (2) | (1) JL04V- 6A22-22SE-EB- R (2) JL04V- 6A22-22SE- EB1-R | (1) JL04V- 8A22-22SE-EB- R (2) JL04V- 8A22-22SE- EB1-R | - | (1) JL04-22EBA (2) - | (1) JL04- 2022CK (14)-R (2) JL04- 2428CK (20)-R |
| | Solder pot diameter φ5.3 Applicable wire (1) 5.5mm ² or less, (2) 10mm ² or less | | | - | Compatible cable O.D. (1) φ12.9 - φ16, (2) φ18 - φ20 | |

Servo Products Specification Guide

Plug Connectors on the Cable Side (support for waterproof IP67)

Listed below are the manufacturer's part numbers for waterproof (conforming to IP67) plug connectors on the cable side, supplied by the manufacturers listed. For details of the connectors, contact each manufacturer.

| Model Name | [D] Single Block Type Plug Connector | [A] Straight Type Plug Connector | [B] Right Angle Type Plug Connector | [B] Low-profile angle type plug connector | [B'] Low-profile housing | [C] Cable Clamp |
|--|---|---|--|--|---|--------------------------------|
| α12/4000HVis | Japan Aviation Electronics Industry | | | | | |
| | JA06A-18-10S-J1-R | JA06A-18-10S-J1-EB-R | JA08A-18-10S-J1-EB-R | | JL04V-18EBA | JL04-18CK (13)-R |
| | Hirose Electric | | | | | |
| | H/MS3106A 18-10S(13) | H/MS3106A 18-10S(10) | H/MS3108B 18-10S(10) | H/MS08A18-10S-DT10D(10) | | H/MS3057 - 10A(10) |
| | DDK Ltd. | | | | | |
| D/MS3106A 18-10S-B(D190) | D/MS3106A 18-10S-B-BSS | D/MS3108A 18-10S-B-BAS | | | CE3057 - 10A-1-D | |
| α22/3000i, α22/3000HVi α22/4000HVis, α30/4000HVis α40/4000HVis, and α50/3000HVis with fan | Japan Aviation Electronics Industry | | | | | |
| | JA06A-22-22S-J1-R | JA06A-22-22S-J1-EB-R | JA08A-22-22S-J1-EB-R | | JL04V-22EBA | JL04-2022 CK (14)-R |
| | Hirose Electric | | | | | |
| | H/MS3106A 22-22S(13) | H/MS3106A 22-22S(10) | H/MS3108B 22-22S(10) | H/MS08A22-22S-DT12D(10) | | H/MS3057 - 12A(10) |
| | DDK Ltd. | | | | | |
| D/MS3106A 22-22S-B(D190) | D/MS3106A 22-22S-B-BSS | D/MS3108A 22-22S-B-BAS | | | CE3057 - 12A-1-D | |

33.4 Connectors for the Brake

The α HViS Series servo motors use a dedicated connector to connect power for the built-in brake. This connector is drip-proof. Because it is connected by soldering, no special tool is required.

This connector differs from conventional connectors used for the α Series. The following subsection explains this connector.

Consider soldering, cable clamp, and voltage drop. Also note that there are restrictions. The connector for the 24-V brake does not conform to the IEC60034 standard.

Connector Specifications

| | |
|---------------------------------------|--|
| Straight type | JN2DS04FK2-R (Japan Aviation Electronics Industry) ZA06B-6114-K213#S (FANUC specification) |
| Right angle | JN2FS04FK2-R (Japan Aviation Electronics Industry) ZA06B-6114-K213#E (FANUC specification) |
| Applicable wire size | AWG#16 or less (1.25mm^2 or less) *Solder pot diameter $\phi 1.9$ |
| Insulation external diameter | $\phi 2.7$ or less |
| Compatible cable O.D. | $\phi 6.5$ to $\phi 8.0$ |
| Example of applicable wire | 300-V two-conductor vinyl heavy-duty power cord cable VCTF (JIS C 3306) or equivalent |
| Applicable wire size and cable length | 0.75mm^2 (AWG#18) when cable length 30m or less 1.25mm^2 (AWG#16) when cable length 50m or less |

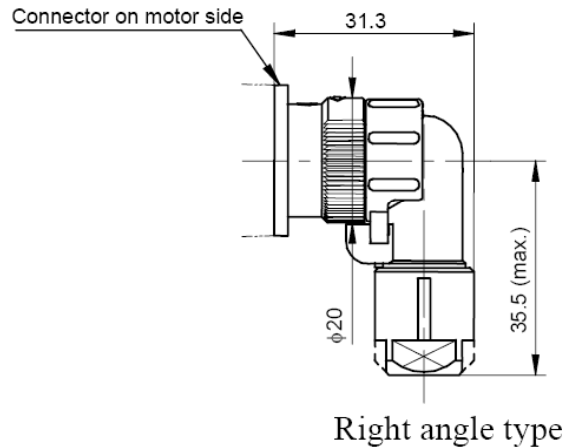
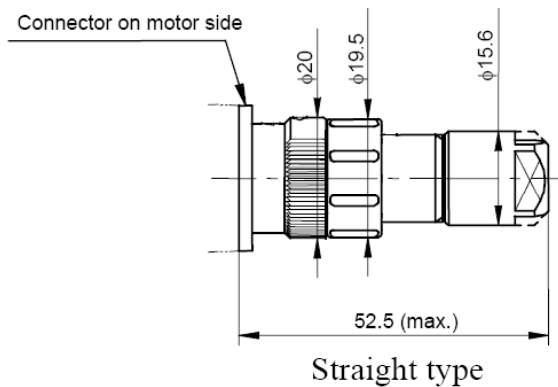

Notes:

- The same body is used for the brake and fan connectors. They differ in the key position to prevent an improper insertion.
- If the cable length is longer than or equal to 50 m, take measures such as installation of repeaters so that the sum of wire resistance (for both ways) becomes 1.5Ω or less.
- For details of brakes, “Built-in Brake” on page IV-14.

33.5 Connectors for the Fan

The α iS 50/3000HV with fan uses a dedicated connector to connect the power supply for the fan.

This connector is drip-proof. Because it is connected by soldering, no special tool is required.

This connector differs from conventional connectors used for the α Series. The following subsection explains this connector.

Consider soldering, cable clamp, and voltage drop. Also note that there are restrictions.

Connector Specifications for α iS 50/3000HV with fan

| | | |
|---------------------------------------|---------------|--|
| Connector Type | Straight type | JN2DS04FK2X-R (Japan Aviation Electronics Industry) ZA06B-6114-K214#S (FANUC specification) |
| | Right angle | JN2FS04FK2X-R (Japan Aviation Electronics Industry) ZA06B-6114-K214#E (FANUC specification) |
| Applicable wire size | | AWG#16 or less (1.25mm^2 or less) *Solder pot diameter $\phi 1.9$ |
| Insulation external diameter | | $\phi 2.7$ or less |
| Compatible cable O.D. | | $\phi 6.5$ to 8.0 |
| Example of applicable wire | | 300-V two-conductor vinyl heavy-duty power cord cable VCTF (JIS C 3306) or equivalent |
| Applicable wire size and cable length | | 0.5 mm^2 or more (AWG#20) |

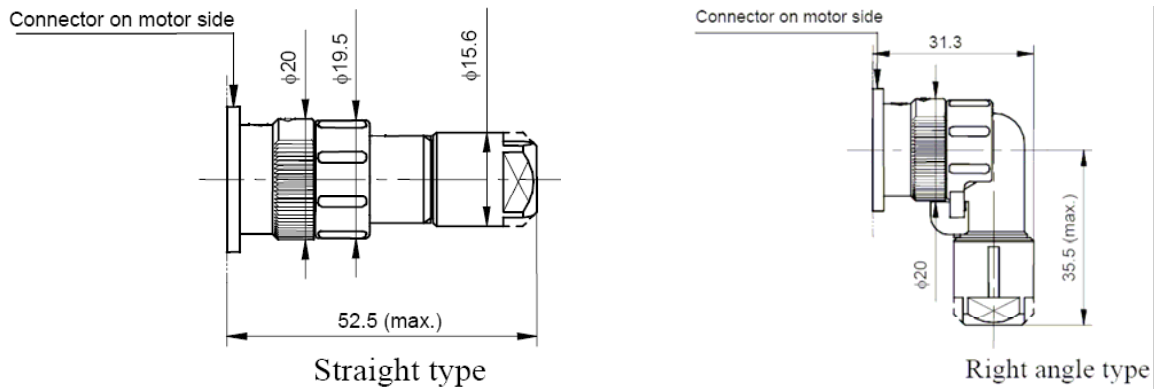

Notes:

- The same body is used for the brake and fan connectors. They differ in the key position to prevent an improper insertion.
- If the cable length is longer than or equal to 50 m, take measures such as installation of repeaters so that the sum of wire resistance (for both ways) becomes 1.5Ω or less.

33.6 Connection to a Conduit Hose

This section provides manufacturer's part numbers for of several adapters that are made by conduit hose manufacturers. Before using an adapter, contact the corresponding conduit hose manufacturer for more details.

Manufacturer's Part Numbers for Conduit Hose Adapters (Waterproof type/seal adapter specifications)

| Model Name | [E] Cable Seal adapter Straight type | [F] Cable Seal adapter Elbow type | [G] Conduit hose Seal adapter Straight type | [H] Conduit hose Seal adapter Elbow type |
|--|---|---|--|--|
| For power | | | | |
| α12/4000HVis | CKD12-18 (SANKEI) YSO 18-12-14 (DAIWA DENGYOU) ACS-12RL-MS18F (NIPPON FLEX) CG12S-JL18 (NEOFLEX) | C90° KD12-18 (SANKEI) YLO 18-12-14 (DAIWA DENGYOU) ACA-12RL-MS18F (NIPPON FLEX) CG12A-JL18 (NEOFLEX) | KKD16-18 (SANKEI) MSA 16-18 (DAIWA DENGYOU) RCC-104RL-MS18F (NIPPON FLEX) MAS16S-JL18 (NEOFLEX) | K90° KD16-18 (SANKEI) MAA 16-18 (DAIWA DENGYOU) RCC-304RL-MS18F (NIPPON FLEX) MAS16A-JL18 (NEOFLEX) |
| α22/3000i, α22/3000HV, α22/4000HV, α30/4000HV, α40/4000HV, and α50/3000HV with fan | CKD16-22 (SANKEI) YSO 22-12-14 (DAIWA DENGYOU) ACS-16RL-MS22F (NIPPON FLEX) CG16S-JL22 (NEOFLEX) | C90° KD16-22 (SANKEI) YLO 22-12-14 (DAIWA DENGYOU) ACA-16RL-MS22F (NIPPON FLEX) CG16A-JL22 (NEOFLEX) | KKD22-22 (SANKEI) MSA 22-22 (DAIWA DENGYOU) RCC-106RL-MS22F (NIPPON FLEX) MAS22S-JL22 (NEOFLEX) | K90° KD22-22 (SANKEI) MAA 22-22 (DAIWA DENGYOU) RCC-306RL-MS22F (NIPPON FLEX) MAS22A-JL22 (NEOFLEX) |
| For signal | | | | |
| Common to all models | | | N2KY16-FN3 (SANKEI) PCJN-12-M13F (DAIWA DENGYOU) RQJN-M13-9 RQJN-M13-16 (NEOFLEX) | |
| For brake | | | | |
| Common to all models | | | N2KY16-FN3 (SANKEI) PCJN-12-M13F (DAIWA DENGYOU) RQJN-M13-9 RQJN-M13-16 (NEOFLEX) | |

(*) ManufactureSANKEI: SANKEI MANUFACTURING CO.,LTD. DAIWA DENGYOU: DAIWA DENGYOU CO.,LTD. NIPPON FLEX: NIPPON FLEX CO.,LTD. NEOFLEX

33.7 System Connection Diagram and Cable Reference

Motor and amplifier connector kits required for the system are available from GE Fanuc. The following figures indicate the physical connector locations on the amplifiers, the appropriate connector designations and connector kit part numbers.

The following diagrams illustrate typical system interconnections. For details on cables and connectors, refer to Table 93HIV-29 on page IV-60.

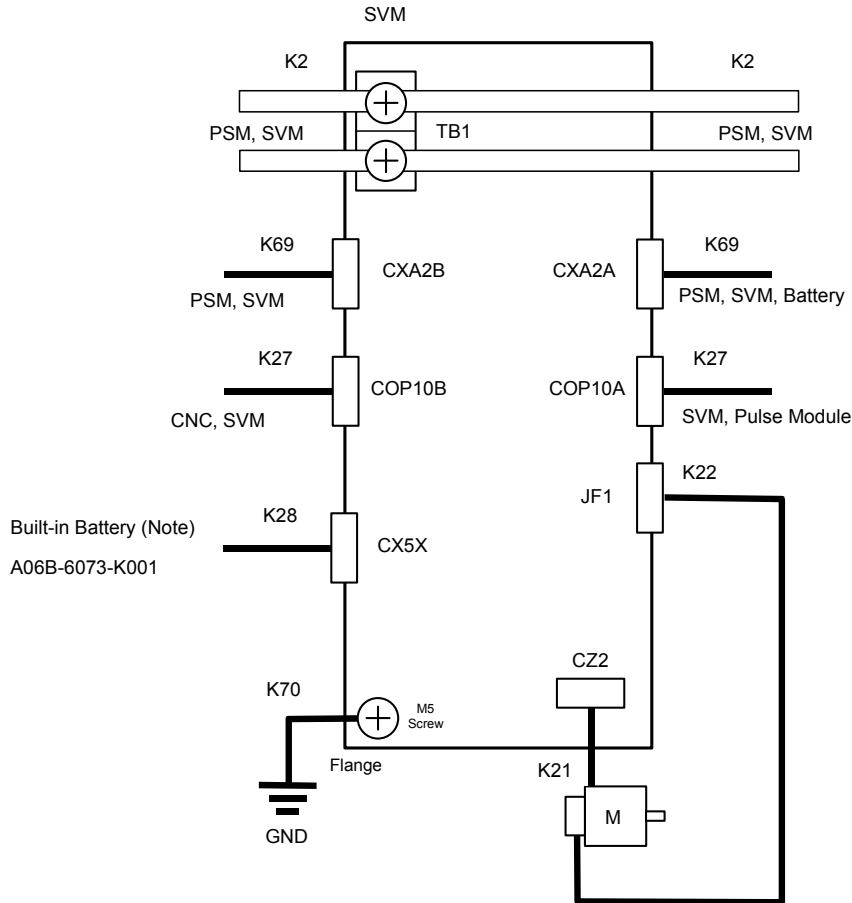

Note: See page IV-24 for details on connection to the battery or the built-in battery.

Connector Location

| Name | Cable | Description |
|---------------|-------|-------------------------------------|
| TB1 | K2 | DC link |
| CXA2A/CXA2B | K69 | Communication cable between modules |
| COP10A/COP10B | K27 | FSSB interface |
| CX5X | K28 | Built-in battery connector |
| CZ2L | K21 | Output power to servo motor |
| JF1 | K22 | Serial encoder feedback |
| CZ2M | K21 | Output power to servo motor |
| | K70 | Protective ground connection |

Figure IV-27. alphaSVM1-40i and alphaSVM1-80i Connection Diagram

Servo Products Specification Guide

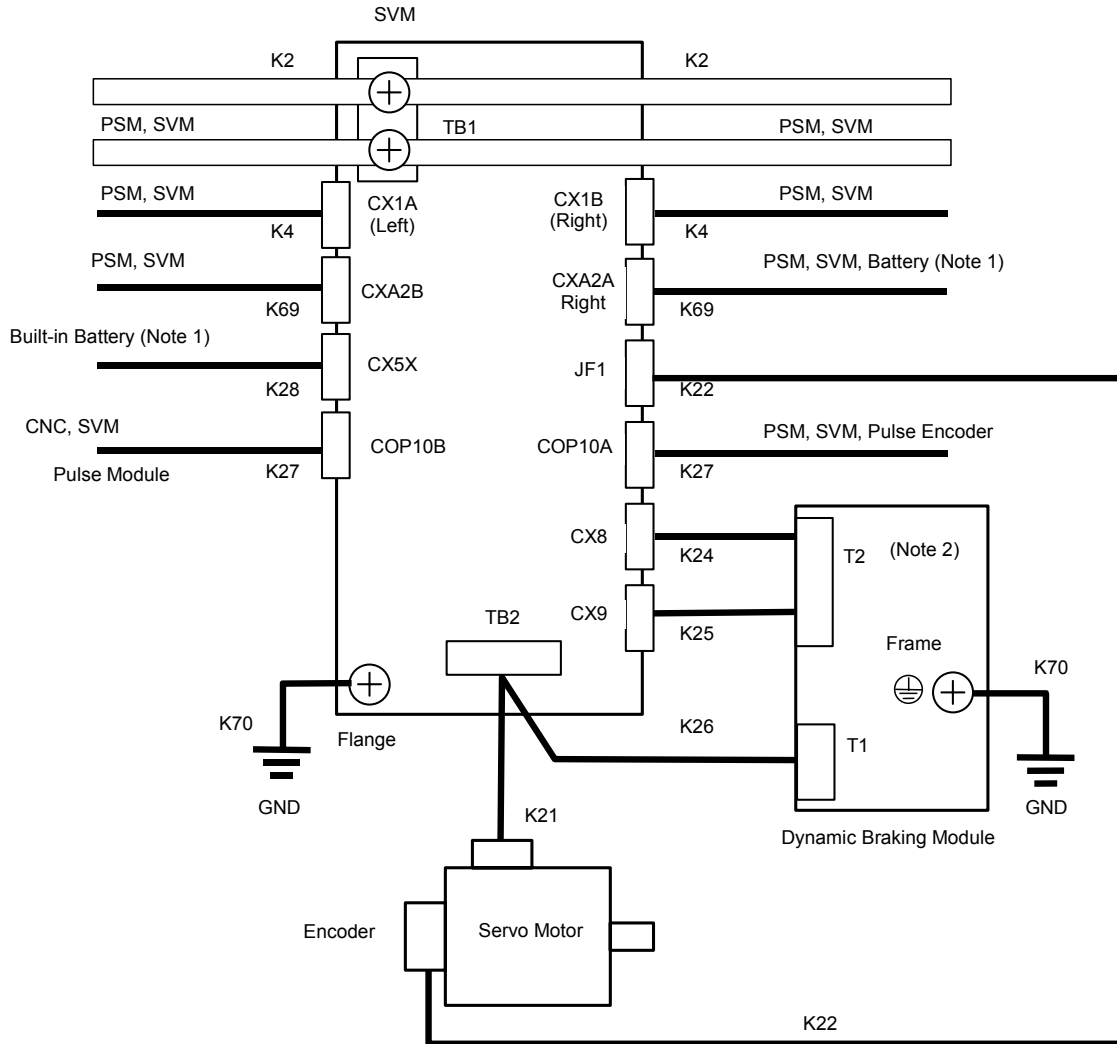

- Note:** 1. See page IV-24 for details on connection to the multi-axis battery pack or the built-in battery.
2. Connect one dynamic brake module for each servo amplifier.

Connector Location

| Name | Cable | Description |
|---------------|-------|--|
| TB1 | K2 | DC link |
| CX1A/CX1B | K4 | Input power for dynamic brake module |
| CXA2A/CXA2B | K69 | Communication cable between modules (SVM1-180HVi only) |
| CX5X | K28 | Built-in battery connector |
| COP10A/COP10B | K27 | FSSB interface |
| JF1 | K22 | Serial encoder feedback |
| CX8 | K24 | Dynamic brake module |
| CX9 | K25 | Dynamic brake module. |
| TB2 | K26 | Power to dynamic brake module |
| | K21 | Power to servo motor |
| ⊕ | K70 | Protective ground connection |

Figure IV-28. aSVM1-180HVi Connection Diagram

Servo Products Specification Guide

Table IV-29. System Connection Cables Summary

| Ref. | Connects | GE Fanuc Cable Part Number | When Required |
|-------------|---|-----------------------------------|--|
| K1 | Main power to Power Supply Module | Customer supplied | Always |
| K2 | DC Link | See page IV-62 for details. | Always |
| K4 | Dynamic Brake Module | Customer supplied. | SVM-180i only |
| K21 | Output power to Servo Motor | Customer supplied. | Always |
| K22 | Serial Encoder feedback | Customer supplied | Always |
| K24 | Dynamic Brake Interlock Signals | Customer supplied | SVM-180i only |
| K25 | Dynamic Brake Driving Coil | Customer supplied | SVM-180i only |
| K26 | Power to Dynamic Brake Module | Customer supplied | SVM-180i only |
| K27 | FSSB interface | See page IV-70 for details. | Always |
| K28 | Built-in Battery | Customer supplied | Always |
| K69 | Optional External Absolute Encoder Battery Connection | Customer supplied | When external absolute encoder operation is required |
| K70 | Protective ground | Customer supplied | Always |

33.8 Cable Details

Details of Cable K1 – AC Power to PSM-HVi Power Supply

Cable K1 is used to supply main power to the power supply module.

Make sure that the cable used between the power supply and power supply module satisfies the requirements listed below.

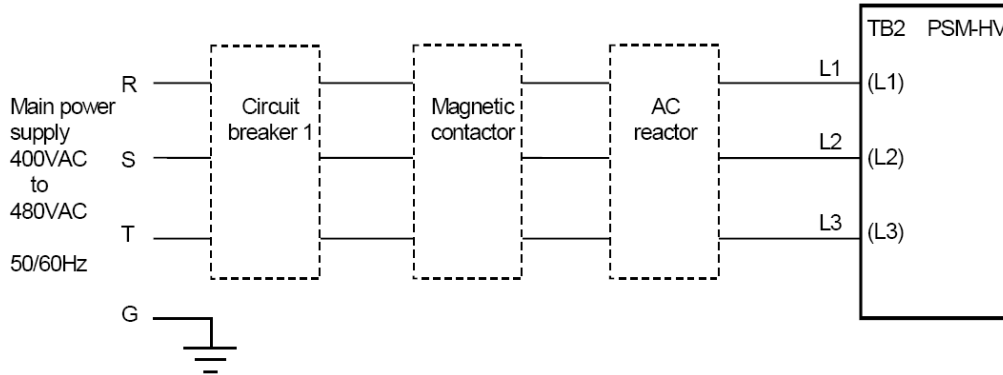

Cable K1 Specifications

| Model | Heavy Duty Power Cable (Note 1) | Heat Resistant Cable (Note 2) | Terminal Screw | Tightening Torque |
|-----------|---------------------------------|-------------------------------|----------------|-------------------|
| PSM-11HVi | 5.5 mm ² minimum | 5.5 mm ² minimum | M4 | 1.1 to 1.5 Nm |
| PSM-18HVi | NA | 8 mm ² minimum | M4 | 1.1 to 1.5 Nm |
| PSM-30HVi | NA | 14 mm ² minimum | M6 | 3.5 to 4.5 Nm |
| PSM-45HVi | NA | 22 mm ² minimum | M6 | 3.5 to 4.5 Nm |

Notes:

- 1) Four-conductor polyvinyl heavy-duty power cable (JIS C3312) (VCT: heat-resistant 60°C)
- 2) Fire-retardant polyflex wire (heat-resistant 105°C) or equivalent to LMFC manufactured by The Furukawa Electric Co., Ltd.
- 3) The cross-section area of each cable is determined under the following conditions:
 At PSM rated output
 Ambient temperature of cable: 30°C
 Number of harnesses: 3 (No current flows through the ground wire during normal operation.)
- 4) Select the required cable cross-section area according to the user environment and conditions.

Servo Products Specification Guide

Details of Cable K2 - DC Link Bus Bars

A set of bars is used to supply the DC link voltage generated in each power supply module to the connected amplifier. When designing a bus bar for connecting modules placed close to each other, refer to "Specifications of bus bars for connecting modules placed close to each other."

To determine the length of the bus bars to be used for connecting modules placed separately, refer to "Location of Terminal Board on Each Module."

For convenience, bus bar kits are available from GE Fanuc. Part numbers for these kits are shown in the table below.

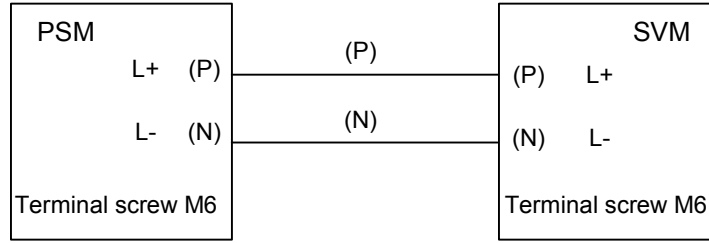

Specifications of bus bars for connecting modules placed close to each other

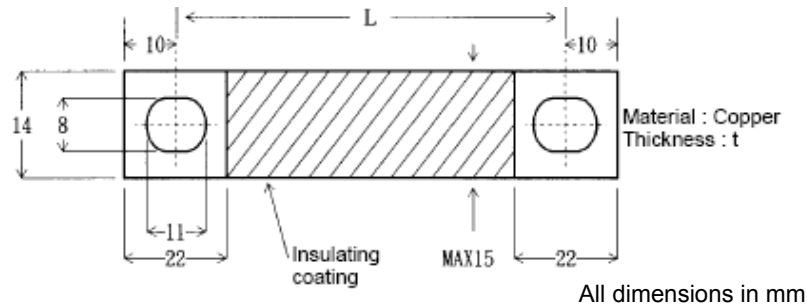

Bus Bar Specifications

| Module Width | Bus Bar Length (L) | Bus Bar Thickness (t) | Cross-Section Area* | Bus Bar Kit Part Number |
|--------------|--------------------|-----------------------|---------------------|-------------------------|
| 150mm | 150mm | 1.5mm | 21mm ² | Z44A718031-G12 |
| 90mm | 90mm | 1.5mm | 21 mm ² | Z44A718031-G03 |
| 60mm | 60mm | 1.5mm | 21 mm ² | Z44A718031-G05 |

* If the modules cannot be placed close to each other, they do not need to be connected with a bus bar (copper plate). If you connect them with a power cable, the cable may not be thinner than the recommended cross-section area and must be insulated with heat-resistant polyvinyl.

Servo Products Specification Guide

Location of Terminal Board on Each Module

The figure below shows the location of terminal board TB1 on each module.

If you want to install modules at distances not specified herein, design bus bars or power cables for the DC Link connection by referring to the dimensions shown below.

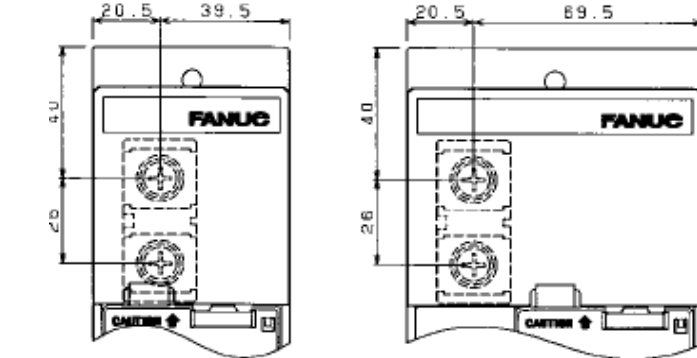

60mm-Wide Module
αSVM1-40HV; αSVM1-80HV

90mm-Wide Module
PSM-11HV; PSM-18HV

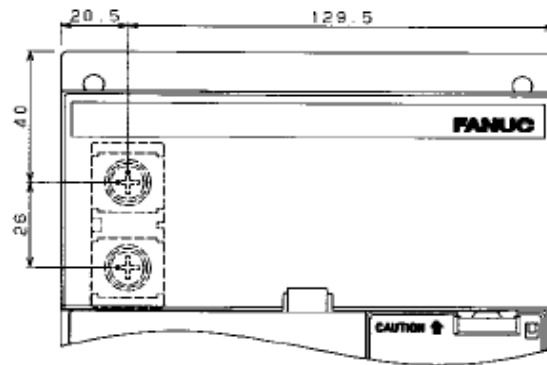

60mm-Wide Module
αSVM1-180HV; PSM-30HV;
PSM-40HV

All dimensions in mm

Details of Cable K4 – Dynamic Brake Module Power (SVM1-180HVi Amplifier Only)

Cable K4 is a connection cable used to supply power (single phase, 200 VAC) for driving the dynamic brake unit connected to an SVM1-180 HVI amplifier.

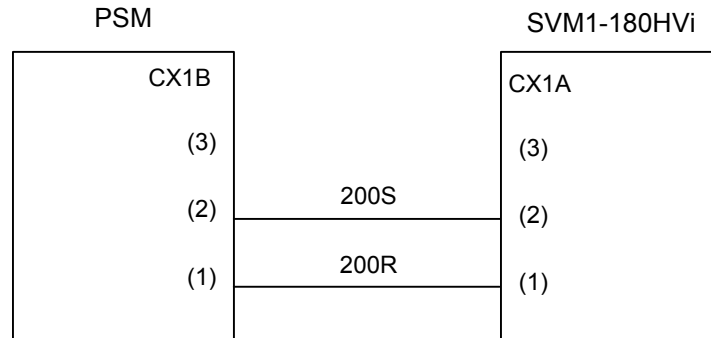

Example cable:

Two-conductor polyvinyl heavy-duty power cable (JIS C3312)

Conductor size: 1.25mm² (50/0.18)

PVC sheath: 9.6 mm in diameter

Connector specification:

Tyco Electronics AMP connector with receptacle housing

1-178128-3 and receptacle contact 1-175218-2

GE Fanuc Part Number: ZA02B-0120-K321 (two required)

Details of Cable K21 – Motor Power to α SVM1-40HVi and α SVM1-80HVi Amplifiers

The cable K21 is a power cable used between the SVM amplifier and motor. The cable is attached to the SVM through the D-5000 series connector (ZA06B-6110-K203#ZZN).

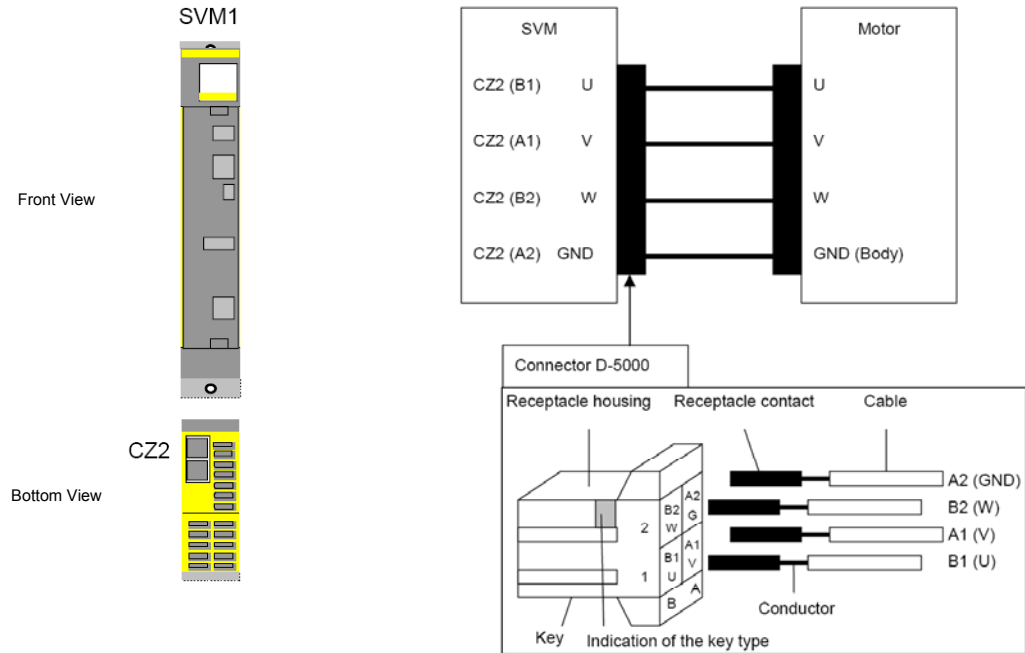

Note: When the α HVi series amplifier is used, always mount the motor so that it is connected to the system ground. If it is not possible to connect the motor flange to the system ground, connect the motor flange and frame ground (ground plate of the cabinet) using a cable at least 1.25 mm² thick. The cable must be separated from the power lines as much as possible.

SVM1 Amplifier CZ2 Motor Power Connector

Specification of the D-5000 for SVM1 Amplifiers

Receptacle Housing: 1-917807-2

GE Fanuc Part Number: ZA06B-6110-K203#ZZ

The CZ2 connector uses an SS size contact.

| Contact model number | Conductor size (mm ²) | Conductor size AWG | Insulation outer diameter (mm) | Manual tool model number |
|----------------------|-----------------------------------|--------------------|--------------------------------|--------------------------|
| SS size 1318986-6 | 0.50 – 1.42 | 20/18 | 1.08-3.23 | 1366656-1 |

Cable Considerations

Consider the following conditions for use when selecting the motor power cable.

1. Motor current rating or actual current needed for motor loaded based on application requirements.
2. Cable type (heat resistance temperature, etc.)
3. Environment in which the cable is installed (operating ambient temperature, etc.).
4. Need for waterproofing. (Note the diameter of the applicable cable clamp.)
5. Certification for CE marking (compliance with various safety standards and EMC standard)
6. Securing insulation space among the cable pins at the time of cabling

Motor Connector

The specification of the motor power connector varies from one motor model to another.

Refer to “Motor Power Connectors on page IV-48 for motor power connector part numbers.

Details of Cable K21 – Motor Power to α SVM1-180HV*i* Amplifier

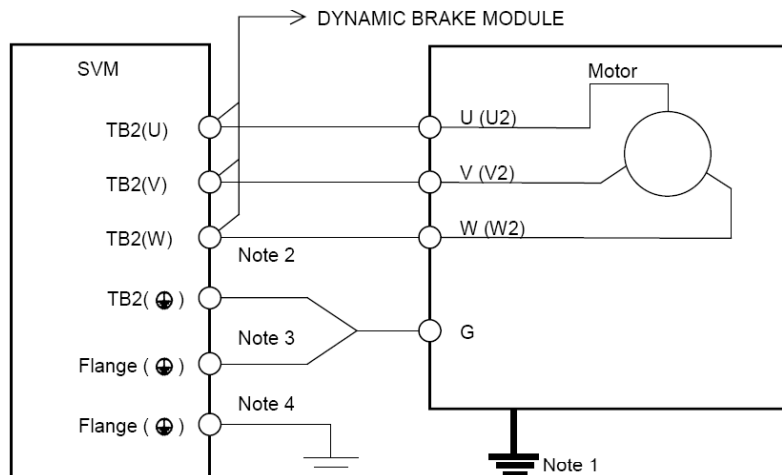

Notes:

1. When the α HV*i* Series amplifier is used, always mount the motor so that it is connected to the system ground. If it is not possible to connect the motor flange to the system ground, connect the motor flange and frame ground (ground plate of the cabinet) using a cable at least 1.25 mm² thick. The cable must be separated from the power lines as much as possible.
2. Size of screw for motor power line TB2 (U), TB2 (V), and TB2 (W): M6
3. Size of screw for motor ground lead TB2 (G): M6
4. Size of screws for connection between motor flange and ground: M5

Details of Cable K22 – Motor Serial Encoder Feedback

The cable K22 is used to connect the αSVM amplifier and motor serial encoder.

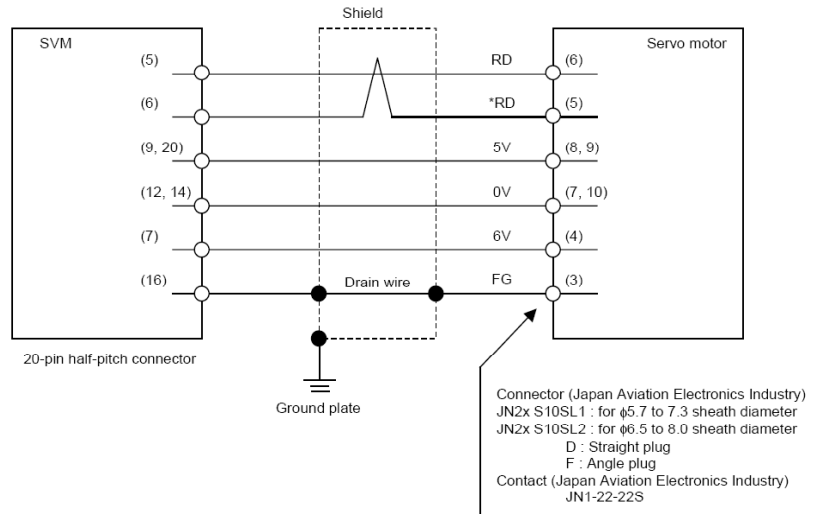

Cable Conductors

| Signal name | Cable length: 28m or less | Cable length: 50m or less |
|-------------|---|--|
| 5V, 0V, 6V | 0.3mm ² × 5 Strand configuration 12/0.18 or 60/0.08 Insulation outer diameter φ0.8 to φ1.5 | 0.5mm ² × 5 Strand configuration 20/0.18 or 104/0.08 Insulation outer diameter φ0.8 to φ1.5 |
| RD, *RD | 0.18mm ² or more Twisted-pair wire Insulation outer diameter φ0.8 to φ1.5 | 0.18mm ² or more Twisted-pair wire Insulation outer diameter φ0.8 to φ1.5 |
| Drain wire | 0.15mm ² or more | 0.15mm ² or more |

Notes:

1. The ground plate to which the shield is connected must be placed as close as possible to the servo amplifier so that distance between the ground plate and the servo amplifier is minimized.
2. The total resistance of the complete wiring run, comprised of the 5V and 0V lines, must be less than 2Ω. Higher resistance will reduce the supply voltage to the serial encoder, possibly resulting in unreliable operation of the encoder.
3. The encoder connector can accept a maximum wire size of 0.5mm² (wire construction 20/0.18 or 104/0.08, diameter Φ1.5 or less) wire and sheath diameter is Φ5.7 to Φ8.0. When using thicker wire or cable, take the measures described below.

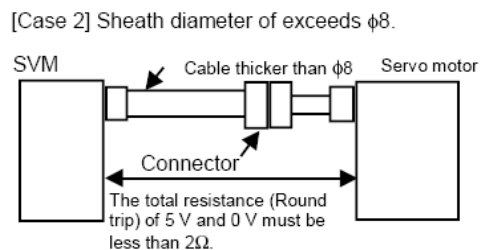
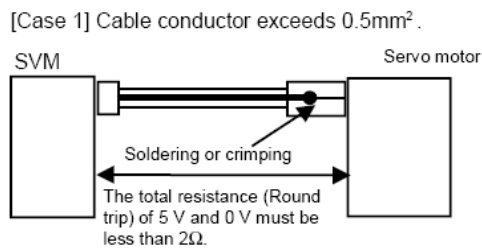

Servo Products Specification Guide

Crimp tool part numbers:

A06B-6114-K201/JN1S: For 0.3 mm²

A06B-6114-K201/JN1L: For 0.18 mm² or 0.5 mm²

GE Fanuc part numbers for connector kits:

ZA06B-6114-K204#S: Straight plug (kit includes contacts)

ZA06B-6114-K204#E: Elbow plug (kit includes contacts)

Details of Cable K24 – Dynamic Brake Module Interlock Signals

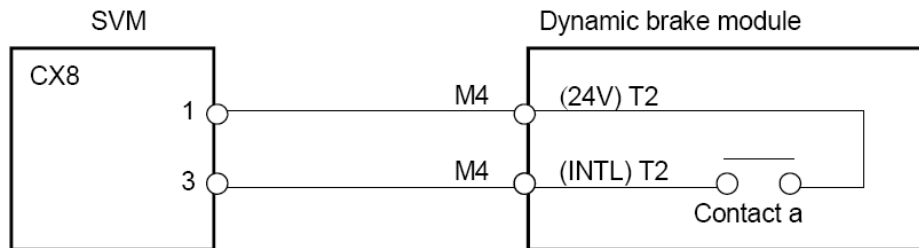

Example cable:

Two-conductor polyvinyl heavy-duty power cable (JIS C3312)

Conductor size: 1.25mm² (50/0.18)

PVC sheath 9.6 mm in diameter

Connector specification:

Tyco Electronics AMP connector with receptacle housing

2-178128-3 and receptacle contact 1-175218-2

Crimping terminal: 2-4

GE Fanuc part number: ZA06B-6073-K216

Details of Cable K25 – Dynamic Brake Driving Coil

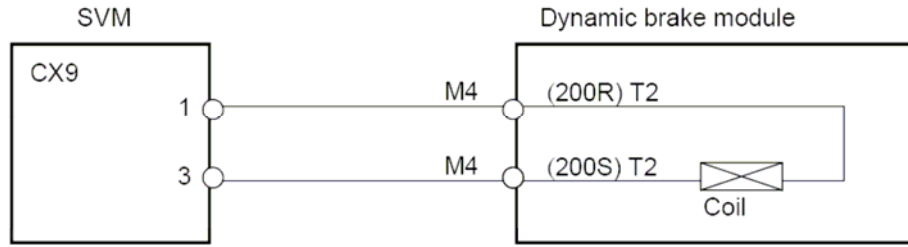

Example cable:

Two-conductor polyvinyl heavy-duty power cable (JIS C3312)
 Conductor size of: 1.25mm² (50/0.18)
 PVC sheath 9.6 mm in diameter

CX9 Connector specification:

Tyco Electronics AMP connector with receptacle housing
 1-178128-3 and receptacle contact 1-175218-2
 Crimping terminal: 2-4
 GE Fanuc part number: ZA06B-6073-K216

Details of Cable K26 – Power to Dynamic Brake Module

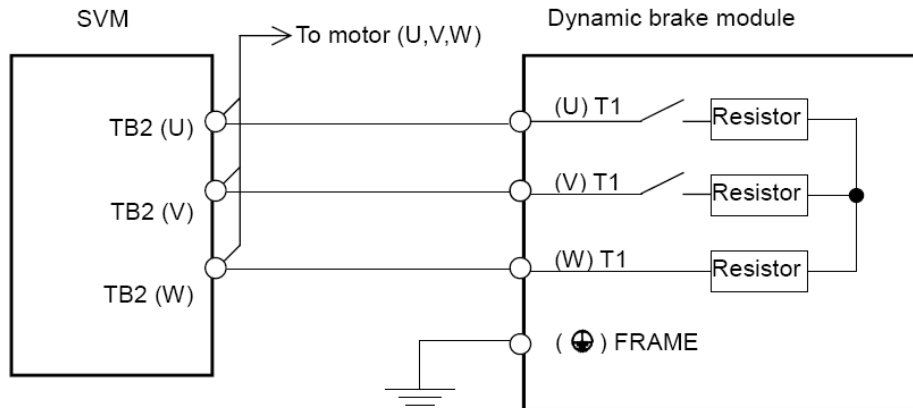

Example cable:

Fire-retardant polyflex wire (maximum conductor temperature 105°C) or equivalent to LMFC
 manufactured by The Furukawa Electric Co., Ltd., 5.5 mm² or larger
 TB2 screw terminal size: M6

Details of Cable K27 - FSSB Fiber Optic Servo Command Interface Cable

The optical cable is available in various lengths and is used to interface up to four amplifiers to the DSM324i or PACMotion controller. Additionally the fiber optic cables come in two styles.

| Cable Type | Length* | Part Number |
|--|----------------|------------------------|
| PVC Covered Fiber Optic Cable (use in sealed cabinet only) | 0.15 meter | ZA66L-6001-0023#L150R0 |
| | 0.30 meter | ZA66L-6001-0023#L300R0 |
| | 1 meter | ZA66L-6001-0023#L1R003 |
| | 3 meter | ZA66L-6001-0023#L3R003 |
| Sheathed Fiber Optic Cable* | 1 meter | ZA66L-6001-0026#L1R003 |
| | 3 meter | ZA66L-6001-0026#L3R003 |
| | 5 meter | ZA66L-6001-0026#L5R003 |
| | 10 meter | ZA66L-6001-0026#L10R03 |
| | 20 meter | ZA66L-6001-0026#L20R03 |
| | 30 meter | ZA66L-6001-0026#L30R03 |
| | 50 meter | ZA66L-6001-0026#L50R03 |

*Longer lengths are available but are not stocked

WARNING

GE Fanuc cannot guarantee the servo performance and reliability unless the fiber optic command interface cable meets or exceeds the stated specifications.

FSSB Cable Specifications

Connector maker: Tyco Electronics AMP. Parts list:

| Connector Part | Vendor Part Number |
|-----------------------|---------------------------|
| Ferrule | 316892 |
| Housing | 316890 |
| Stopper | 316891 |
| Spring | 900357 |

- Cable material must be Multi-mode
- Cable loss (max.): 3dB
- The transmission rate is 25Mbps.
- The fiber used is plastic clad silica fiber. The core diameter is 200 micrometer, and the plastic clad diameter is 230 micrometer.
- The initial loss is 0.015dB per meter (At room temperature).
- The type of light is LED. The wavelength of light is 650nm.
- Bend radius minimum: 50mm.
Life: ~10 million cycles at 100mm radius, @ +/- 90 degrees .
- Twist angle maximum: 360 degrees.
Life: 900,000 cycles @ +/- 180 degrees twisting.
- The cable must be clamped so that no stretching force is applied and no forces within 200mm (8 inches) of connector.

FSSB Cable Connections

Each aHVi Series amplifier has two FSSB connectors labeled C0P10A and C0P10B. Connector C0P10A is an optical transmitter and C0P10B is an optical receiver. Proper system operation requires that the FSSB cables be installed on the proper connector as shown below.

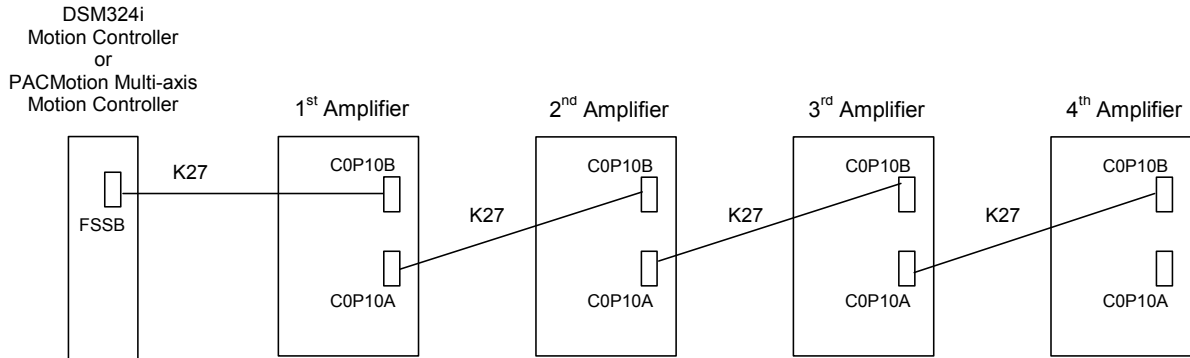

Details of Cable K28

Cable K28 is used to connect the single-axis lithium battery, which is used to power the absolute serial encoder on the motor when power is removed from the SVM amplifier. This cable and connector is part of the lithium battery assembly included in the IC800ABK002 and IC800ABK003 battery kits.

Details of Cable K69 – PSM Interface to SVM Amplifiers

The cable K69 is used between the PSM and SVM when supplying power from one IC800ABK001 multi-axis encoder battery unit to more than one SVM amplifier. This cable interface is also used to supply 24VDC power from the PSM power supply module to all connected SVM amplifiers. Additionally, all connected SVM amplifiers can share a system emergency stop (ESP) signal.

Warning

When using the built-in battery (IC800ABK002 or IC800ABK003), never connect the BATL(B3) of the connector CXA2A/CXA2B. Otherwise, a short-circuit will occur between the battery output voltages for different SVMs, possibly resulting in the batteries becoming very hot, which is dangerous.

Do not connect more than one IC800ABK001 multi-axis battery kit to the same BATL(B3) line. Otherwise, a short-circuit will occur between the output voltages of different batteries, possibly resulting in the batteries becoming very hot, which is dangerous.

Up to six servo motors can be connected to one battery. The life of the batteries is about two years if they are used for six ai series servo motors.

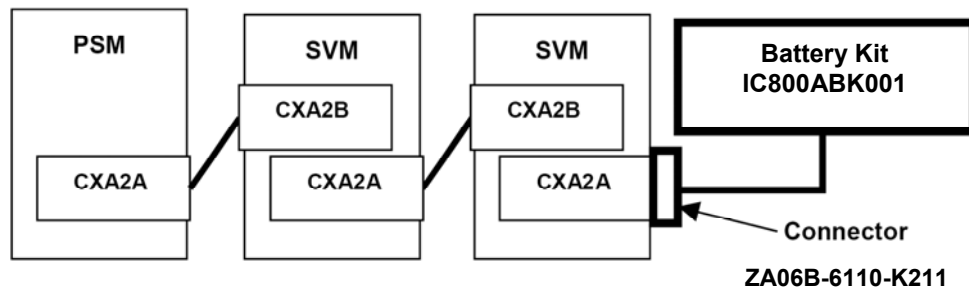

Figure IV-29. Supplying Power from One Battery to Multiple Amplifiers

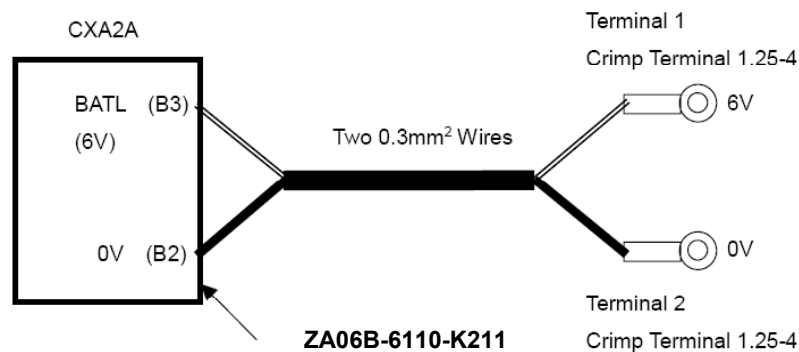

Figure IV-30. Connection Between IC800ABK001 Battery Unit and SVM Amplifier

Servo Products Specification Guide

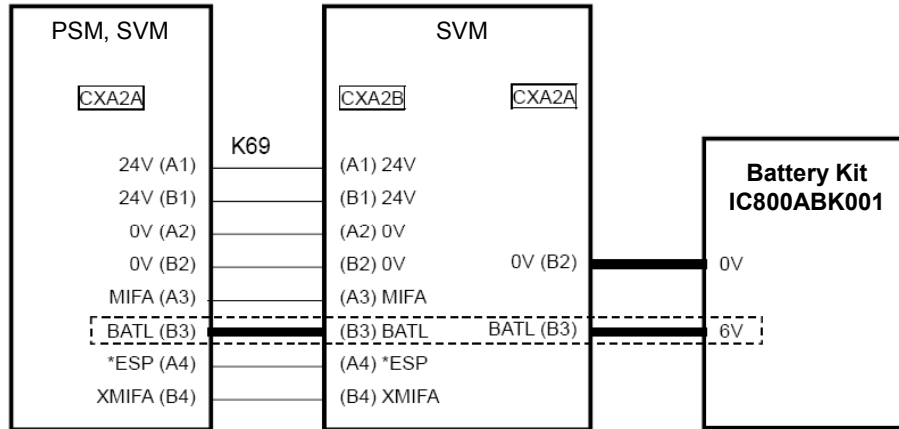

Figure IV-31. PSM Interface Connection Between Modules

The BATL(B3) connector is an interface for supplying power from one absolute Encoder battery unit to more than one SVM amplifier.

CXA2A/CXA2B Connector and Cable Options for K69

| <i>Option</i> | <i>Part Number</i> |
|--|--------------------|
| Connector only | ZA06B-6110-K210 |
| 200mm cable with connector for use with IC800ABK001 battery backup kit | Z44C746453-001 |
| 200mm cable with connectors for use with IC800ABK002 or IC800ABK003 battery backup kit, or no battery | Z44C746453-002 |

ZA06B-6110-K210 Connector Specification

This connector is required when building cable K69.

| <i>Manufacturer</i> | <i>AMP Japan, Ltd</i> |
|----------------------------|--|
| Connector Specification | D-2100 series Housing 1-1318119-4 (quantity: 1) Contact 1318107-1 (quantity: 8) GE Fanuc part number: ZA06B-6110-K210 |
| Conductor size | 0.5mm ² : AWG20 |

Servo Products Specification Guide

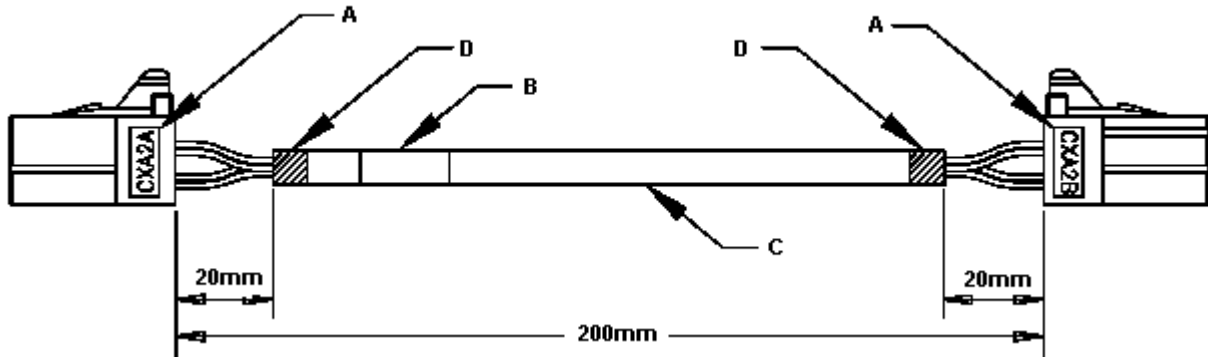

| | |
|---|---|
| A | ZA06B-6110-K210 connectors. |
| B | Mark cables with date, part number and revision number. Cable markings should be permanent, smear-proof and oil proof. |
| C | Cable type: 20 AWG, stranded CU, 80°C, 300V, 8 conductor, PVC jacket, Alpha 5058C or equivalent. Unused ends should be cut at cable jacket. |
| D | Heat shrink tubing, 0.5". |

| CXA2A/CXA2B Pin | Signal | |
|----------------------------|-----------------------------|-----------------------------|
| | Z44C746453-001 Cable | Z44C746453-002 Cable |
| A1 | 24V | 24V |
| A2 | 0V | 0V |
| B1 | 24V | 24V |
| B2 | 0V | 0V |
| A3 | MIFA | MIFA |
| B3 | BATL | No connection |
| A4 | ESP | ESP |
| B4 | XMIFA | XMIFA |

Figure IV-32. CXA2A/CXA2B Connector and Cable Details

Details of Cable K70 – Ground Connection

Connect the SVM mounting flange to the cabinet grounding plate through a grounding cable (protective ground connection).

The ground cable K70 represents the following ground connections:

- a. the connector CX1A on the power supply module to the frame ground of the cabinet.

Conductor size: 1.25 mm²

- b. the metal frame of the power supply module to the frame ground of the cabinet.
- c. the metal frames of the servo amplifier module to the frame ground of the cabinet.

The cable K70 is used to connect the metal frame of the dynamic brake module (DBM) to the frame ground of the cabinet. Select the size of the cable according to the following table. The cross-section size of the motor power cable listed in the table complies with the conductor diameter of the motor power cable used in a unit to which the DBM is connected.

Grounding Cable Conductor Diameter

| <i>Motor power cable cross-section S (mm²)</i> | <i>Grounding cable cross-section (mm²)</i> |
|---|---|
| S ≤ 5.5 | 5.5 or greater |
| 5.5 < S ≤ 16 | S or greater |
| 16 < S ≤ 35 | 16 or greater |
| 35 < S | S/2 or greater |

Note: The following M5 crimp terminal can be used with a cable having a large conductor diameter.

Nichifu Co., Ltd. CB22-5S

Overall conductor size range: 16.78 to 22.66 mm²

Index

- #**
- α Servo System
 - BLOCK DIAGRAM, I-2, II-2
 - PACKAGE OPTIONS, I-8, II-10
 - SPECIFICATIONS, II-9
 - α Servo system specifications, I-7
 - α SVU Series, I-2
 - α SVU1 Amplifier Connections, I-41
 - β HVi Servo System
 - HEAT DISSIPATION, III-33
 - INSTALLATION, III-29
 - MOTOR OUTLINE DRAWINGS, III-11
 - OVERVIEW, 1, III-2
 - SPEED-TORQUE CURVES, III-9
 - SYSTEM CONNECTION, III-49
 - β HVis Servo System
 - SERVO MOTOR SPECIFICATIONS, III-8
 - β i Servo System
 - AMPLIFIERS, III-20
 - HEAT DISSIPATION, III-33
 - INSTALLATION, III-29, IV-30
 - MOTOR OUTLINE DRAWINGS, III-11
 - OVERVIEW, 1, III-2
 - PACKAGE OPTIONS, III-6
 - SERVO MOTOR SPECIFICATIONS, III-7
 - SPEED-TORQUE CURVES, III-9
 - SYSTEM CONNECTION, III-49
- A**
- Absolute Encoder Battery, I-10, II-11, III-26, IV-27
 - AC line filter, II-26, III-38, IV-40
 - AC power, I-30, I-33, II-26, II-28, III-38, III-40, IV-40, IV-45
 - Alarm Functions*, I-57, II-50, III-21, IV-20
 - Amplifier Control Power, II-29, III-41
 - Amplifier Package, α Series, I-6
 - Amplifiers
 - α HEAT DISSIPATION, I-12, II-13
 - β HVI HEAT DISSIPATION*, III-31
 - β I AND β HVI MODELS, III-4
 - β I HEAT DISSIPATION*, III-31, IV-33
 - ALARM FUNCTIONS, I-21, I-57, II-19, II-50, III-21, IV-20
 - β HVi, III-22
 - β i, III-22
 - α HVi, IV-21
 - α i, IV-21
 - CONNECTOR KIT, II-33
 - α Series, I-42, II-32
 - ENVIRONMENTAL REQUIREMENTS, I-11, II-12
 - MAINTENANCE CLEARANCES, II-13
 - MODELS, I-6, II-8, III-4
 - AHVI HEAT DISSIPATION, IV-33
 - AI AND AHVI KITS, IV-3
 - AI AND AHVI MODELS, IV-3
 - Axial Load, I-21, II-19
- B**
- Battery Packs, Encoder, I-10
 - β HVI SERIES, III-26
 - β I SERIES, III-26
 - AHVI SERIES, IV-27
 - AI SERIES, IV-27
 - Battery, Packs Encoder, II-11
 - Bearing, I-21, II-19
 - Block diagram, I-2, II-2
 - Brake, I-9
 - α SERIES MOTOR, I-5, II-6
 - β HVI SERIES MOTOR, III-16
 - β I SERIES MOTOR, III-16
 - AHVI SERIES MOTOR, IV-14
 - AI SERIES MOTOR, IV-14
 - Brake Power Supply, I-5
- C**
- Cables, α Series
 - K10-EMERGENCY STOP/POWER ENABLE CABLE, I-54
 - K10-EMERGENCY-STOP/POWER ENABLE CABLE, II-48
 - K11-SEPARATE REGENERATIVE DISCHARGE UNIT FAN SUPPLY CABLE, I-55
 - K12-24 VDC AMPLIFIER POWER CABLE, II-48
 - K12-MOTOR BRAKE POWER CONNECTION, I-55
 - K13-24 VDC POWER DAISY CHAIN CABLE, II-49
 - K13-COOLING FAN POWER CONNECTION, I-56
 - K14-MOTOR BRAKE POWER CABLE, II-49
 - K1-SERVO COMMAND SIGNAL CABLE, I-45, II-36
 - K2-MOTOR ENCODER FEEDBACK CABLE, I-47
 - K2-MOTOR ENCODER FEEDBACK CABLE (β 0.5/3000), II-38
 - K2-MOTOR ENCODER FEEDBACK CABLE (β 2/3000, β 6/2000), II-39
 - K3-THREE-PHASE SERVO POWER CABLE, I-48, II-41
 - K4-MOTOR AC POWER CABLE (β 2/3000, β 6/2000), II-43
 - K4-MOTOR POWER CABLE (β 0.5/3000), II-42
 - K4-MOTOR POWER CABLE (α 12/3000, α 22/2000), I-48
 - K4-MOTOR POWER CABLE (α 30/3000, α 40/2000), I-50

K4-MOTOR POWER CABLE (α 30/3000,
 α 40/2000), I-49
 K4-MOTOR POWER CABLE (α C 12/2000), II-
 44
 K5-AMPLIFIER STOP CONNECTION, I-51
 K5-EMERGENCY STOP CONNECTION, II-45
 K6-AMPLIFIER CONTROL POWER
 CONNECTION, I-51
 K7-REGENERATIVE DISCHARGE CABLE, II-
 46
 K7-SEPARATE REGENERATIVE
 DISCHARGE UNIT POWER CABLE, I-52
 K8-REGENERATIVE DISCHARGE
 THERMAL PROTECTION CABLE, II-46
 K8-SEPARATE REGENERATIVE
 DISCHARGE UNIT THERMAL
 PROTECTION CABLE, I-52
 K9-ABSOLUTE ENCODER BATTERY
 CABLE, II-47
 K9-OPTIONAL ABSOLUTE ENCODER
 BATTERY CABLE, I-53
 MOTOR ENCODER FEEDBACK CABLE
 (α C12/2000, II-40
 OVERVIEW, I-43, II-34
 Cables, β i and β HVi Series
 K10, III-84
 K2-AC POWER TO β SVM1-20I AMPLIFIER,
 III-71
 K2-AC POWER TO \square SVM1-40I AMPLIFIER,
 III-72
 K2-MOTOR POWER TO \square SVM1-40I
 AMPLIFIER, III-74
 K3-MOTOR POWER TO \square SVM1-20I
 AMPLIFIER, III-73
 K4, III-75
 K6, III-80
 K7, III-81
 K8, III-82
 K9, III-83
 Cables, β i Series
 K1-MOTOR SERIAL ENCODER FEEDBACK,
 III-69
 Catalog Numbers
 α SERIES, I-6
 β SERIES, II-8
 β I SERIES, III-4
 Circuit breaker, I-32, II-27, III-39, IV-42
 Clearances
 AMPLIFIER, I-12, II-13
 Connection
 DETAILS, I-45, II-36
 Connectors
 α SERIES MOTORS, I-42, II-32
 Contactor rating, I-32, II-27, III-39
 Control Power, I-33
 Crimp tools
 FOR β CX11 CONNECTORS, II-33

D

DC power, II-29, III-41
 Dimensions
 β SERIES AMPLIFIER, II-20
 α SERIES AMPLIFIER PANEL CUTOUTS, I-
 22
 α SERIES AMPLIFIERS, I-22
 α SERIES REGENERATIVE D.U., I-38
 α SERIES REGENERATIVE D.U., III-44
 AC LINE FILTERS, I-31
 DISCHARGE RESISTOR, I-39, III-44
 Discharging regenerative energy, I-34, II-29,
 III-42
 Dissipation
 AMPLIFIER, I-12, II-13, III-31, IV-33
 Dynamic Braking Module, IV-24

E

Encoder
 BATTERY, I-10, II-11
 β HVi series, III-26
 β i series, III-26
 α HVi series, IV-27
 α i series, IV-27
 Environmental requirements
 α AMPLIFIERS, I-11, II-12
 α SERIES, I-11, II-12
 β HVI AMPLIFIERS, III-30
 β HVI SERIES, III-29
 β I AMPLIFIERS, III-30
 β I SERIES, III-29
 MOTORS, I-11, II-12, III-29, IV-30
 AHVI AMPLIFIERS, IV-31
 AHVI SERIES, IV-30
 AI AMPLIFIERS, IV-31
 AI SERIES, IV-30

F

Feedback, I-42
 Fuses, II-29, III-41

G

Ground fault interrupter
 α SERIES, I-29, II-25
 Grounding
 α SERIES, I-26
 β SERIES, II-21
 β I AND β HVI SERIES, III-34
 AI AND AHVI SERIES, IV-35
 Grounding Clamp, I-28

H

Heat dissipation
 α SERIES, I-12
 β SERIES, II-13
 β HVI, III-33
 β HVI SERIES, III-31

β I, III-33
 β I SERIES, III-31
AHVI, IV-34
AHVI SERIES, IV-33
AI, IV-34
AI SERIES, IV-33
High Response Vector function, I-4, II-4, III-9, IV-8

I

Installation Guidelines, I-11, II-12
 β HVI, III-29
 β I, III-29
AHVI, IV-30
AI, IV-30

L

Line Filter, I-30, II-26, III-38, IV-40

M

Maintenance Clearances, II-13, III-31, IV-33
Motor Dimensions
 β 0.5/3000, II-14
 α 12/3000, I-15
 β 2/3000, II-15
 β 2/3000 W/BRAKE, II-17
 α 22/3000, I-15
 α 30/3000, I-15
 α 40/2000, I-18
 β 6/2000, II-15
 β 6/2000 W/BRAKE, II-17, II-18
 α 6/3000, I-13
 α C12/2000, II-15
 α C12/2000 W/BRAKE, II-17, II-18
 β M0.5/4000, II-18
 β M1/4000, II-18
Motor outline drawings
 β HVI SERVO SYSTEM, III-11
 β I SERVO SYSTEM, III-11
AHVI SERVO SYSTEM, IV-10
AI SERVO SYSTEM, IV-10
Motor Power, I-42
Motors, I-9
BRAKE, I-5, I-9, II-6, III-16, IV-14
ENVIRONMENTAL REQUIREMENTS, I-11, II-12, III-29, IV-30
SPEED-TORQUE CURVES, IV-8
HRV function, I-4, II-4, III-9

N

Noise Protection
 α SERIES, I-26, II-21
 β HVI SERIES, III-34
 β I SERIES, III-34
AHVI SERIES, IV-35
AI SERIES, IV-35

O

Optional Connectors, I-42
Options

α SERIES, I-8, II-10
 β I SERIES, III-6
AI SERIES, IV-4

Overview

α SERIES, I-3, II-3
 β HVI SERIES, III-2
 β I SERIES, III-2
AHVI SERIES, IV-2
AI SERIES, IV-2

P

Package Options, I-8, II-10

β I, III-6
AI, IV-4

Part Numbers

α SERIES, I-6, II-8
 β HVI SERIES, III-4
 β I SERIES, III-4

Power Line Protection, I-30, II-26, III-38, IV-40

Power requirements

α SERIES, I-30, II-26
 β SERIES AC POWER, II-26
 α SERIES CIRCUIT BREAKERS, I-32, II-27
 α SERIES DISCHARGING REGENERATIVE ENERGY, I-34, II-29
 α SERIES ELECTROMAGNETIC CONTACTOR, I-32, II-27
 α SERIES INCOMING AC POWER, I-30
 β HVI SERIES, III-38
 β HVI SERIES AC POWER, III-38
 β HVI SERIES CIRCUIT BREAKERS, III-39
 β HVI SERIES DISCHARGING REGENERATIVE ENERGY, III-42
 β HVI SERIES ELECTROMAGNETIC CONTACTOR, III-39
 β I SERIES, III-38
 β I SERIES AC POWER, III-38
 β I SERIES CIRCUIT BREAKERS, III-39
 β I SERIES DISCHARGING REGENERATIVE ENERGY, III-42
 β I SERIES ELECTROMAGNETIC CONTACTOR, III-39
AC POWER, I-33, II-28, III-40, IV-45
INCOMING DC POWER, III-41
INCOMING DC POWER, II-29
AHVI SERIES, IV-40
AHVI SERIES AC POWER, IV-40
AHVI SERIES CIRCUIT BREAKERS, IV-42
AI SERIES, IV-40
AI SERIES AC POWER, IV-40
AI SERIES CIRCUIT BREAKERS, IV-42

Protection

- α* SERIES, I-57, II-50
- β*HVI SERIES, III-21
- β*I SERIES, III-21
- AHVI SERIES, IV-20
- AI SERIES, IV-20

R

- Radial Load, I-21, II-19
- Regenerative Discharge Units
 - α* SERIES, I-34
 - β* SERIES, II-29
 - β*I SERIES, III-42
- Regenerative energy, I-34
 - CALCULATING FOR *α* SERIES, I-34, II-30
 - CALCULATING FOR *β*I SERIES, III-47
- Regenerative Energy, II-29, III-42

S

- Sealing Option, I-9
- Servo package options, I-8, II-10
 - β*I, III-6
 - AI, IV-4
- Shaft Loading
 - α* SERIES, I-21, II-19
- Specifications
 - α* SERIES, I-7
 - β* SERIES, II-9
- Speed-Torque curves
 - α* SERIES, I-4, II-4
 - β*HVI SERIES, III-9
 - β*I SERIES, III-9
 - AHVI SERIES, IV-8
 - AI SERIES, IV-8

Switch Settings, I-25, III-43

T

- Tools
 - FOR A06B-6110-K200#XXS CONNECTOR, III-72
 - FOR A06B-6110-K202#YYs CONNECTOR, III-74
 - FOR A06B-6130-K200 CONNECTOR, III-71, III-73
- Tools, crimp
 - FOR *β* CX11 CONNECTORS, II-33
- Transformer, I-30, II-26, III-38, IV-40

A

- α*HVi Servo System
 - HEAT DISSIPATION, IV-34
 - INSTALLATION, IV-30
 - MOTOR OUTLINE DRAWINGS, IV-10
 - OVERVIEW, IV-2
 - SPEED-TORQUE CURVES, IV-8
 - SYSTEM CONNECTION, IV-46
- α*HVis Servo System
 - SERVO MOTOR SPECIFICATIONS, IV-6, IV-7
- α*i Servo System
 - AMPLIFIERS, IV-19
 - HEAT DISSIPATION, IV-34
 - MOTOR OUTLINE DRAWINGS, IV-10
 - OVERVIEW, IV-2
 - PACKAGE OPTIONS, IV-4
 - SERVO MOTOR SPECIFICATIONS, IV-5
 - SPEED-TORQUE CURVES, IV-8
 - SYSTEM CONNECTION, IV-46