

GE
Intelligent Platforms

Motion Solutions Products

Servo Products

Specification Guide, GFH-001G

April 2010



Warnings, Cautions, and Notes as Used in this Publication

Warning

Warning notices are used in this publication to emphasize that hazardous voltages, currents, temperatures, or other conditions that could cause personal injury exist in this equipment or may be associated with its use.

In situations where inattention could cause either personal injury or damage to equipment, a Warning notice is used.

Caution

Caution notices are used where equipment might be damaged if care is not taken.

Note: Notes merely call attention to information that is especially significant to understanding and operating the equipment.

This document is based on information available at the time of its publication. While efforts have been made to be accurate, the information contained herein does not purport to cover all details or variations in hardware or software, nor to provide for every possible contingency in connection with installation, operation, or maintenance. Features may be described herein which are not present in all hardware and software systems. GE Intelligent Platforms assumes no obligation of notice to holders of this document with respect to changes subsequently made.

GE Intelligent Platforms makes no representation or warranty, expressed, implied, or statutory with respect to, and assumes no responsibility for the accuracy, completeness, sufficiency, or usefulness of the information contained herein. No warranties of merchantability or fitness for purpose shall apply.

* indicates a trademark of GE Intelligent Platforms, Inc. and/or its affiliates. All other trademarks are the property of their respective owners.

Contact Information

If you purchased this product through an Authorized Channel Partner, please contact the seller directly.

General Contact Information

Online technical support and GlobalCare	http://www.ge-ip.com/support
Additional information	http://www.ge-ip.com/
Solution Provider	solutionprovider.ip@ge.com

Technical Support

If you have technical problems that cannot be resolved with the information in this guide, please contact us by telephone or email, or on the web at www.ge-ip.com/support

Americas

Online Technical Support	www.ge-ip.com/support
Phone	1-800-433-2682
International Americas Direct Dial	1-780-420-2010 (if toll free 800 option is unavailable)
Technical Support Email	support.ip@ge.com
Customer Care Email	customercare.ip@ge.com
Primary language of support	English

Europe, the Middle East, and Africa

Online Technical Support	www.ge-ip.com/support
Phone	+800-1-433-2682
EMEA Direct Dial	+352-26-722-780 (if toll free 800 option is unavailable or if dialing from a mobile telephone)
Technical Support Email	support.emea.ip@ge.com
Customer Care Email	customercare.emea.ip@ge.com
Primary languages of support	English, French, German, Italian, Czech, Spanish

Asia Pacific

Online Technical Support	www.ge-ip.com/support
Phone	+86-400-820-8208
	+86-21-3217-4826 (India, Indonesia, and Pakistan)
Technical Support Email	support.cn.ip@ge.com (China)
	support.jp.ip@ge.com (Japan)
	support.in.ip@ge.com (remaining Asia customers)
Customer Care Email	customercare.apo.ip@ge.com
	customercare.cn.ip@ge.com (China)

Part I: α Servo System	I-1
Section 1: α SVU Series Servo System Block Diagram	I-2
Section 2: α Series Servo Product Overview	I-3
2.1 α Series Motors	I-3
2.2 α Series Motor–Torque Curves	I-4
2.3 α Series motor holding brake	I-5
2.4 α SVU Series Servo Amplifiers	I-6
Section 3: α Series Servo System	I-7
Section 4: α Servo System Options	I-8
4.1 IP67 Sealing Option on α Series Servo Motors	I-9
4.2 Absolute Encoder Battery Packs	I-10
Section 5: Installation Guidelines	I-11
5.1 Motor Environmental Requirements	I-11
5.2 Servo Amplifier Environmental Requirements	I-11
5.3 α SVU Series servo amplifier heat Dissipation	I-12
5.4 α Series Motor Dimensions	I-13
5.5 Shaft Loading	I-21
5.6 α SVU1 Series Amplifier and Panel Cutout Dimensions	I-22
5.7 α SVU Series Switch Settings	I-25
5.8 Noise Protection	I-26
5.9 Command Cable Grounding	I-28
5.10 Selecting a Ground Fault Interrupter	I-29
Section 6: α Servo System Power Requirements	I-30
6.1 Power Line Protection	I-30
6.2 AC Line Filter	I-30
6.3 Circuit Breaker Selection	I-32
6.4 Electromagnetic Contactor (MCC) Rating	I-32
6.5 Incoming AC Power	I-33
6.6 Discharging Regenerative Energy	I-34
Section 7: α Servo System Connection	I-41
7.1 α SVU1 Amplifier Connections	I-41
7.2 α System Connections	I-42
7.3 α SERIES Servo Connection Diagram	I-44
7.4 Connection Details	I-45
Section 8: α SVU Series Protection and Alarm Functions	I-57
 Part II: β Servo System	 II-1
Section 9: β Servo System Block Diagram	II-2
Section 10: β Series Servo Product Overview	II-3
10.1 β Series Motors	II-3
10.2 β Series Motor Speed–Torque Curves	II-4
10.3 β Series Motor Holding Brake	II-6
10.4 β Series Servo Amplifiers	II-8

Contents

Section 11: β Series Servo System Specifications	II-9
Section 12: β Servo System Options	II-10
12.1 Absolute Encoder Battery Packs	II-11
Section 13: Installation Guidelines.....	II-12
13.1 Motor Environmental Requirements	II-12
13.2 Servo Amplifier Environmental Requirements.....	II-12
13.3 β servo Amplifier heat dissipation and maintenance	II-13
13.4 β and β M Series Motor Dimensions.....	II-14
13.5 Shaft Loading.....	II-19
13.6 β Series Amplifiers Dimensions	II-20
13.7 Noise Protection	II-21
13.8 Command Cable Grounding	II-24
13.9 Selecting a Ground Fault Interrupter	II-25
Section 14: β Servo System Power Requirements.....	II-26
14.1 Power Line Protection.....	II-26
14.2 AC Line Filter.....	II-26
14.3 Circuit Breaker Selection	II-27
14.4 Electromagnetic Contactor Rating.....	II-27
14.5 Incoming AC Power	II-28
14.6 Incoming DC Power.....	II-29
14.7 Discharging Regenerative Energy.....	II-29
Section 15: β Servo System Connection	II-32
15.1 System Connections.....	II-32
15.2 β Series Connection Diagram.....	II-35
15.3 Connection Details.....	II-36
15.4 β Series Amplifier Protection and Alarm Functions	II-50

Part III: β i and β HVi Series Servo SystemsIII-1

Section 16: β i and β HVi Series Servos Overview.....	III-2
16.1 β i and β HVi Series Servo Systems	III-2
16.2 β i Series Servo Amplifier Packages	III-4
Section 17: β i Servo System Options	III-6
Section 18: Servo Motors	III-7
18.1 Servo Motor Specifications	III-7
18.2 β is and β HVis Series Motor Speed–Torque Curves.....	III-9
18.3 Motor Outline Drawings	III-11
18.4 β is and β HVis Series Servo Motor Holding Brake	III-16
18.5 Brake Power Supply Circuit.....	III-17
18.6 Motor Connections.....	III-19
Section 19: β i and β HVi Amplifiers	III-20
19.1 Amplifier Electrical Specifications.....	III-20
19.2 β i and β VHi Series Amplifier Environmental Specifications	III-20
19.3 β i & β HVi Series Amplifier Status LED and Alarm Functions	III-22
19.4 Amplifier External Dimensions.....	III-24

19.5	Absolute Encoder Battery Options	III-29
Section 20:	Installation Guidelines.....	III-35
20.1	β is and β HVi Motor Environmental Requirements.....	III-35
20.2	β is & β HVi Servo Amplifier Environmental Requirements	III-36
20.3	β i and β HVi Amplifier Heat Dissipation and Maintenance Clearance..	III-37
Section 21:	Heat Dissipation.....	III-39
Section 22:	Noise Protection	III-40
22.1	Separation of Signal and Power Lines	III-40
22.2	Grounding	III-40
22.3	Encoder Feedback Cable Grounding	III-43
Section 23:	β i and β HVi Servo System Power Requirements	III-44
23.1	Power Line Protection.....	III-44
23.2	AC Line Filter	III-44
23.3	Circuit Breaker Selection	III-45
23.4	Electromagnetic Contactor Rating.....	III-45
23.5	Incoming AC power	III-46
23.6	Incoming DC Power.....	III-47
23.7	Discharging Regenerative Energy.....	III-48
Section 24:	β i and β HVi Series Servo System Connection	III-57
24.1	Connectors on the Motor Side.....	III-59
24.2	Signal Connectors on the Cable Side (Models β 0.2is and β 0.3is).....	III-61
24.3	Signal Connectors on the Cable Side (models β 0.4is to β 22is and β 2HVi to β 22HVi).....	III-62
24.4	Power and Brake Connectors on the Cable Side (models β 0.2is and β 0.3is)	III-64
24.5	Power and Brake Connectors on the Cable Side (models β 0.4is to β 1is)	III-65
24.6	Power and Brake Connectors on the Cable Side (models β 2is, β 2HVi, β 4is and β 4HVi).....	III-66
24.7	Power Connectors on the Cable Side (models β 8is to β 22is and β 8HVi to β 22HVi).....	III-67
24.8	Brake Connectors on the Cable Side (models β 8is to β 22is and β 8HVi to β 22HVi)	III-70
24.9	Connection to a Conduit Hose.....	III-71
24.10	Amplifier Connectors	III-72
24.11	System Connection Diagram and Cable Reference.....	III-73
24.12	Cable Details	III-76
Part IV: αi and αHVi Series Servo Systems.....		IV-1
Section 25:	α i and α HVi Series Servos Overview	IV-2
25.1	α i and α HVi Series Servo Systems.....	IV-2
25.2	α i Series Servo Amplifier Packages	IV-3
Section 26:	α HVi Servo System Options	IV-4
Section 27:	Servo Motors	IV-5
27.1	Servo Motor Specifications	IV-5
27.2	α i and α HVi Series Motor Speed–Torque Curves	IV-8

Contents

27.3	Motor Outline Drawings	IV-10
27.4	Built-in Brake	IV-16
27.5	Motor Connections.....	IV-19
27.6	Cooling Fan	IV-21
Section 28:	α SVM1 Amplifiers	IV-22
28.1	Amplifier Specifications.....	IV-22
28.2	α HVi Series Amplifier Status LED and Alarm Functions	IV-22
28.3	Amplifier External Dimensions.....	IV-24
28.4	Dynamic Braking Module Dimensions.....	IV-26
28.5	Power Supplies.....	IV-27
28.6	Absolute Encoder Battery Options	IV-29
Section 29:	Installation Guidelines.....	IV-32
29.1	α i, α HVi and α HVis Motor Environmental Requirements	IV-32
29.2	α HVi Servo Amplifier Environmental Requirements	IV-33
29.3	Amplifier Heat Dissipation and Maintenance Clearance	IV-35
Section 30:	Heat Dissipation.....	IV-36
Section 31:	Noise Protection	IV-37
31.1	Grounding	IV-37
31.2	Separation of Signal and Power Lines	IV-38
31.3	Cable Clamp and Shield Grounding	IV-39
31.4	Encoder Feedback Cable Grounding	IV-40
Section 32:	α HVi Servo System Power Requirements.....	IV-42
32.1	Power Line Protection.....	IV-42
32.2	AC Line Filter	IV-42
32.3	Circuit Breaker and Magnetic Contactor Selection.....	IV-44
32.4	Incoming AC power	IV-46
Section 33:	α HVi Series Servo System Connection.....	IV-48
33.1	Motor Power Connectors.....	IV-51
33.2	Encoder Connectors for α i, α HVi and α HVis Motors	IV-52
33.3	Connectors for Power.....	IV-54
33.4	Connectors for the Brake.....	IV-58
33.5	Connectors for the Fan.....	IV-59
33.6	Connection to a Conduit Hose.....	IV-60
33.7	System Connection Diagram and Cable Reference.....	IV-61
33.8	Cable Details	IV-65

Introduction

This specification guide provides technical details for the following digital servo systems:

α Series

β Series

β is Series

α i Series

α HVi, β HVi and β i Series servos can be mixed in the same system and/or on the same PACMotion or DSM324i controller module and use the same FSSB fiber optic interface.

For feature comparisons and information on related products, refer to the *Motion Solutions Products Catalog*, GFA-483.

Part I, α Series

The α Series amplifiers can communicate with the DSM300 Series controllers. The PWM interface uses the standard GE Intelligent Platforms digital servo communication protocol.

A motor protection level of IP65 is standard with all α Series motors, and optional IP67 sealing is available on most α Series motors. Torque ratings of 6 to 40 Nm are available on α Series motors.

A 64K absolute encoder is standard on α Series motors. An optional electrically released holding brake is available on all α Series motors.

Additional documentation for α Series:

α Series Servo Motor Descriptions Manual, GFZ-65142E

α Series Servo Amplifier Descriptions Manual, GFZ-65192EN

AC Servo Amplifier Maintenance Manual, GFZ-65005E

α Series Control Motor Maintenance Manual, GFZ-65165E

α Series Control Motor Amplifier Descriptions Manual, GFZ-65162E

Part II, β Series,

The β Series amplifiers can communicate with the DSM 300 Series controllers.

A motor protection level of IP65 is standard with all β Series motors. Torque ratings of 0.5 to 12 Nm are available on β Series motors.

A 32K counts /revolution absolute mode digital encoder is standard with each β Series servo motor. An optional electrically released holding brake is available on all β Series motors.

The β Series motors feature an improved insulation system on the windings and an overall sealing coating helps protect the motor from the environment.

Additional documentation for β Series:

β Series Servo Motor Descriptions Manual, GFZ-65232EN

β Series Servo Motor Maintenance Manual, GFZ-65235EN

Servo Products Specification Guide

Part III, β is Series

The β i Series amplifiers communicate with the PACMotion and DSM324i controllers using the Fanuc Serial Servo Bus (FSSB) fiber optic interface. The FSSB interface uses the standard GE Intelligent Platforms servo communication protocol.

A motor protection level of IP65 is standard with β is Series motors. Torque ratings of 0.4 to 22 Nm are available on the β i Series motors.

β is series motors use 64K or 128K absolute encoders. All β is Series servo motors are available with an optional 24VDC holding brake.

- Additional documentation for β i Series and β HVi Series:

AC Servo Motor β is Series Descriptions Manual, GFZ-65302EN

Servo Amplifier β i Series Descriptions Manual, GFZ-65322EN

AC Servo Motor β is Series, AC Spindle Motor β i Series and AC Servo Amplifier β i Series Maintenance Manual, GFZ-65325EN.

Part IV, α i Series

The α HVi series extend the continuous torque range supported by the PACMotion and DSM324i motion controllers to 75 Nm. There is relatively little overlap between these servos and the β i-Series servos currently supported by the DMS324i. The α 22/3000HVi and α 22/4000HVIs motors have higher rated speeds than the β 22/2000is motor.

Additional documentation for α is Series:

AC Servo Motor α i Series Descriptions Manual, B-65262EN

Servo Amplifier α i Series Descriptions Manual, GFZ-65282EN

Part I:
α Servo
System

Section 1: α SVU Series Servo System Block Diagram

The following block diagram shows the interconnections of a typical α Series servo system:

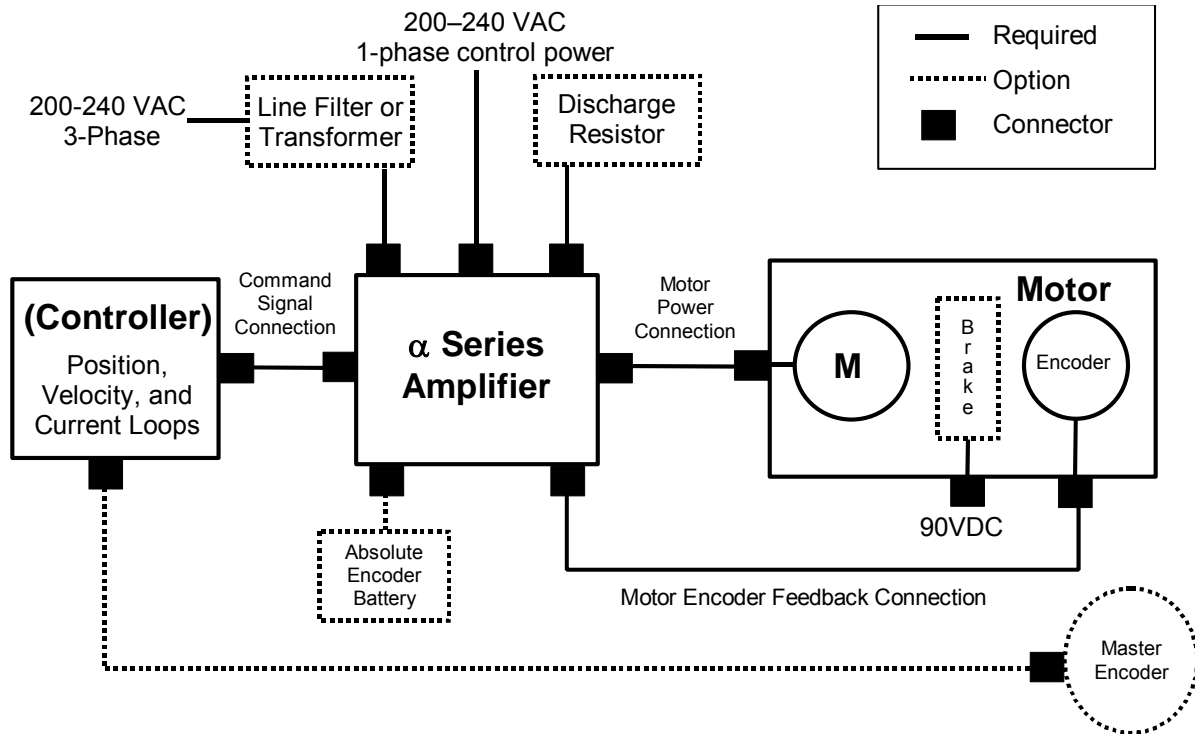

Figure I-1. α SVU Series servo block diagram

NOTE

The 200–240 VAC control power inputs are jumpered to the three-phase bus power inputs (L1C to L1 and L2C to L2) when delivered from the factory. If a separate control power source is desired to maintain alarm status during removal of main bus power, remove the jumper links and connect the separate control power.

Section 2: α Series Servo Product Overview

2.1 α Series Motors

The α Series servo motors include built-in serial encoders with 64K PPR (pulses per revolution) resolution. All α Series motors are available with an optional holding brake, and most are available with an optional IP67 sealing. A fan package is standard on the α 40/2000 servo motor. The servo motors must be used with the designated amplifier package and a GE Intelligent Platforms motion controller such as the Motion Mate DSM300 Series.

Table 3HI-1 provides a summary of the α Series servos. See Section 3: for more detailed motor specifications.

Table I-1. α Series Servo Motors

Motor	Rated Torque	Power Rating	Required Amplifier Kit	Motor Catalog #
α 6/3000	6 Nm (53 in-lbs) continuous stall torque; 3000 RPM (max)	1.4 kW	80 Amp (IC800APK080)	Motor Only: ZA06B-0128-B575#7008 w/ IP67 Sealing: ZA06B-0128-B575#7076 w/ Brake: ZA06B-0128-B675#7008 w/ IP67 Sealing & Brake: ZA06B-0128-B675#7076
α 12/3000	12 Nm (106 in-lbs) continuous stall torque; 3000 RPM (max)	2.8 kW	80 Amp (IC800APK080)	Motor Only: ZA06B-0143-B075#7008 w/ IP67 Sealing: ZA06B-0143-B075#7076 w/ Brake: ZA06B-0143-B175#7008 w/ IP67 Sealing & Brake: ZA06B-0143-B175#7076
α 22/2000	22 Nm (195 in-lbs) continuous stall torque; 2000 RPM (max)	3.7 kW	80 Amp (IC800APK080)	Motor Only: ZA06B-0147-B075#7008 w/ IP67 Sealing: ZA06B-0147-B075#7076 w/ Brake: ZA06B-0147-B175#7008 w/ IP67 Sealing & Brake: ZA06B-0147-B175#7076
α 30/3000	30 Nm (265 in-lbs) continuous stall torque; 3000 RPM (max)	5.2 kW	130 Amp (IC800APK130)	Motor Only: ZA06B-0153-B075#7008 w/ IP67 Sealing: ZA06B-0153-B075#7076 w/ Brake: ZA06B-0153-B175#7008 w/ IP67 Sealing & Brake: ZA06B-0153-B175#7076
α 40/2000 w/ fan package	40 Nm (494 in-lbs) continuous stall torque; 2000 RPM (max)	7.2 kW	130 Amp (IC800APK130)	Motor w/ Fan Package: ZA06B-0158-B075#7008 w/ Fan Package & Brake: ZA06B-0158-B175#7008

2.2 α Series Motor–Torque Curves

The curves shown below illustrate the relationship between the speed of the motor and the output torque. The motor can operate continuously at any combination of speed and torque within the prescribed continuous operating zone. The limit of the continuous operating zone is determined with the motor's ambient temperature at 40°C and its drive current as pure sine wave. Actual operation is limited by the current of the servo drive unit.

α 6/3000

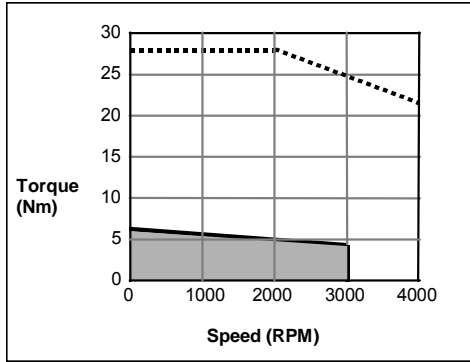

α 12/3000

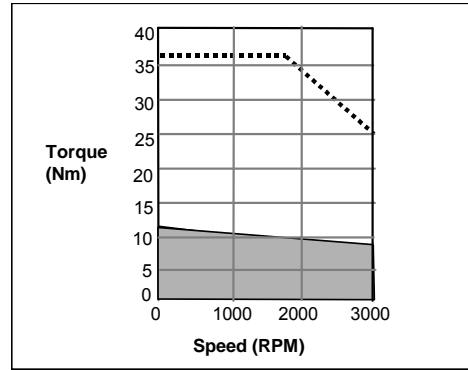

α 22/2000

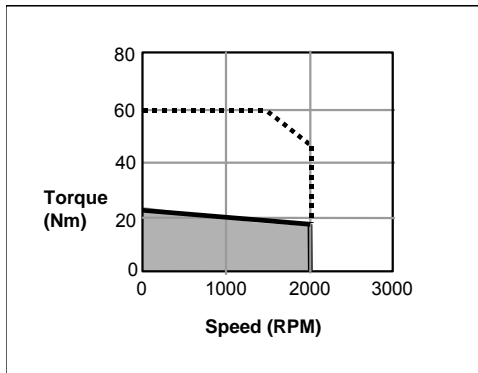

α 30/3000

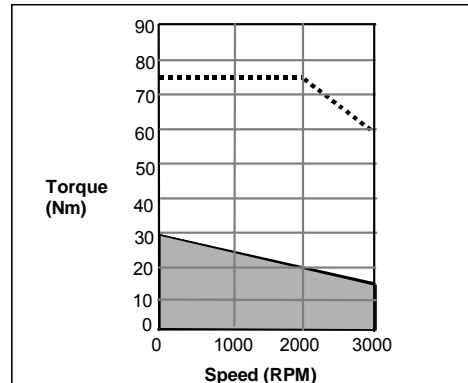

α 40/2000

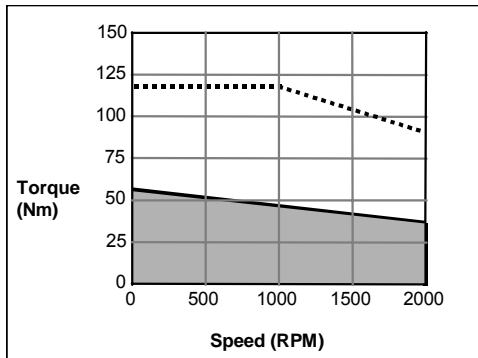

KEY: - - - - = Intermittent operating
 █ = Continuous operating

Figure I-2. α Series Motor Speed-Torque Curves

2.3 α Series motor holding brake

Any of the servo motors can be ordered with a holding brake. The brake is used to prevent movement on horizontal axes or falling along the vertical axis when the servo motor control is turned off.

Brakes are spring-set and electrically released and are designed for holding stationary loads only. Using the holding brake to stop a moving axis may damage the motor or severely reduce its service life.

The specifications of the built-in brakes are listed in Table 6HI-2:

Table I-2. Brake specifications

Parameter	SERVO PACKAGE				
	α 6/3000	α 12/2000	α 22/2000	α 30/3000	α 40/2000
Brake torque	71 in-lb 8 Nm 82 kgf-cm	310 in-lb 35 Nm 357 kgf-cm	310 in-lb 35 Nm 357 kgf-cm	310 in-lb 35 Nm 357 kgf-cm	310 in-lb 35 Nm 357 kgf-cm
Release Response Time	80 msec	150 msec	150 msec	150 msec	150 msec
Brake Response Time	40 msec	20 msec	20 msec	20 msec	20 msec
Supply Voltage and Current	90 VDC ($\pm 10\%$) 0.4 A or less	90 VDC ($\pm 10\%$) 0.6 A or less	90 VDC ($\pm 10\%$) 0.6 A or less	90 VDC ($\pm 10\%$) 0.6 A or less	90 VDC ($\pm 10\%$) 0.6 A or less
Weight Increase	Approx. 5 lb Approx. 2.3 kg	Approx. 13.8 lb Approx. 6.3 kg	Approx. 13.8 lb Approx. 6.3 kg	Approx. 13.8 lb Approx. 6.3 kg	Approx. 22 lb Approx. 10 kg
Inertia Increase	0.00061 in-lb-s ² 0.00007 kg m ² 0.0007 kgf-cm-s ²	0.0052 in-lb-s ² 0.0006 kg m ² 0.006 kgf-cm-s ²	0.0052 in-lb-s ² 0.0006 kg m ² 0.006 kgf-cm-s ²	0.0052 in-lb-s ² 0.0006 kg m ² 0.006 kgf-cm-s ²	0.0087 in-lb-s ² 0.0010 kg m ² 0.010 kgf-cm-s ²

An example of a typical **user-supplied** brake power supply is shown below:

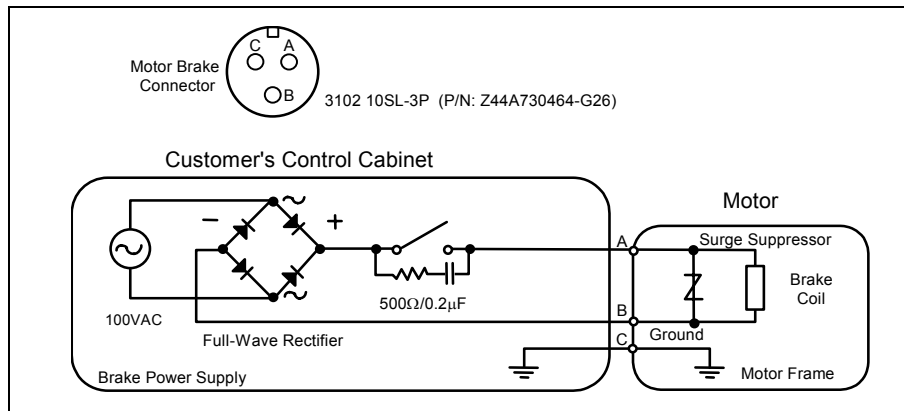

Figure I-3. Typical User-Supplied Brake Power Supply

2.4 α SVU Series Servo Amplifiers

The α SVU Series amplifiers must be matched to the corresponding α Series motor. Because motor characteristics are closely related to amplifier ratings, GE Intelligent Platforms restricts the allowable motor/amplifier combinations to those shown in Table 9HI-3 below.

GE Intelligent Platforms offers α SVU Series amplifiers either separately, for replacement and spare parts, or as preconfigured packages that include the connectors and spare fuses necessary for most new installations. The catalog numbers for both options and package contents are shown in the following tables.

Table I-3. α SVU Series models

Motor	Amplifier Model	Amplifier Catalog #	Amplifier Package Catalog #
α 6/3000	SVU1-80	ZA06B-6089-H105	IC800APK080
α 12/3000	SVU1-80	ZA06B-6089-H105	IC800APK080
α 22/2000	SVU1-80	ZA06B-6089-H105	IC800APK080
α 30/3000	SVU1-130	ZA06B-6089-H106	IC800APK130
α 40/2000	SVU1-130	ZA06B-6089-H106	IC800APK130

Table I-4. α SVU Series packages

Description	Package Contents*	Catalog #
80 Amp α Series Amplifier Package	<ul style="list-style-type: none"> • 1 SVU1-80 Amp (ZA06B-6093-H105) • 1 Fuse (ZA06B-6089-K250) • 1 External MCC Connector (ZA06B-6089-K201) • 1 E-Stop Connector (ZA02B-0120-K321) 	IC800APK080
130 Amp α Series Amplifier Package	<ul style="list-style-type: none"> • 1 SVU1-130 Amp (ZA06B-6093-H106) • 1 External MCC Connector (ZA06B-6089-K201) • 1 E-Stop Connector (ZA02B-0120-K321) • 2 Fuses (ZA06B-6089-K250) 	IC800APK130

* If required, amplifier package components can be ordered separately.

Section 3: α Series Servo System

The α Series Servo system consists of a motor and its corresponding amplifier. GE Intelligent Platforms offers several servo systems, which are identified in Table 12HI-5 below.

Table I-5. Identification of servo systems

Parameter (Unit)	SERVO SYSTEM				
	$\alpha 6/3000$	$\alpha 12/3000$	$\alpha 22/2000$	$\alpha 30/3000$	$\alpha 40/2000$ (w/fan)
MOTOR					
Rated output power (kW)	1.4	2.8	3.8	4.8	7.3
Rated torque at stall (Nm) *	6.0	12	22	30	56
Rated torque at stall (in-lb) *	53	106	195	265	495
Rated torque at stall (kgf-cm) *	61	122	225	306	571
Rated output speed (RPM)	3000	3000	2000	3000	2000
Rotor inertia (kg m ²)	0.002646	0.006272	0.01176	0.01666	0.02254
Rotor inertia (in-lb-s ²)	0.02343	0.0555	0.1041	0.1475	0.1996
Rotor inertia (kg-cm-s ²)	0.027	0.064	0.12	0.17	0.23
Continuous RMS current at stall A (rms)	10.0	15.5	18.7	33.7	40.1
Torque constant (Nm/A [rms]) *	0.60	0.77	1.17	0.89	1.40
Torque constant (in-lb/A [rms]) *	5.3	6.8	10.4	7.9	12.4
Torque constant (kgf-cm/A [rms]) *	6.1	7.9	12.0	9.1	14.3
Back EMF constant (V/1000 RPM) *	21	27	41	31	49
Back EMF constant (Vsec/rad) *	0.20	0.26	0.39	0.30	0.47
Armature resistance (Ω) *	0.18	0.17	0.140	0.046	0.080
Mechanical time constant (s) *	0.004	0.005	0.004	0.003	0.003
Thermal time constant (min)	50	60	65	70	30
Static friction (Nm)	0.3	0.8	1.2	1.8	1.8
Static friction (in-lb)	2.7	7.1	10.6	15.9	15.9
Static friction (kgf-cm)	3	8	12	18	18
Maximum allowable current (A [peak])	132	120	160	320	270
Maximum theoretical torque (Nm) **	56	66	130	200	270
Maximum theoretical torque (in-lb) **	496	584	1150	1770	2390
Maximum theoretical torque (kgf-cm) **	571	670	1400	2100	2800
Weight (kg)	13	18	29	41	55
Weight (lb)	28.6	39.6	63.8	90.2	121
AMPLIFIER					
Amplifier model	SVU1-80	SVU1-80	SVU1-80	SVU1-130	SVU1-130
Rated output current (rms amps)	18.7	18.7	18.7	52.2	52.2
Current limit (Peak amps)	80	80	80	130	130
Heat loss (watts)	37.7	47.3	54	70.9	80.7
230 VAC 1 ϕ control power current (A)	0.13	0.13	0.13	0.26	0.26
Weight (kg)	4.9	4.9	4.9	9.9	9.9
Weight (lb)	10.8	10.8	10.8	21.8	21.8

* These values are standard values at 20°C with a tolerance of $\pm 10\%$. The speed-torque characteristics vary, depending on the type of software, parameter setting, and input voltage of the digital servo amplifier. (The above figures show average values.) These values may be changed without prior notice.

** Theoretical values. The actual maximum torque is restricted by the current limit values of the drive amplifier.

Section 4: α Servo System Options

Designing a servo control system requires that you understand how the electrical and mechanical aspects of your system interact. GE Intelligent Platforms application engineers are available to help you determine your control system requirements.

Table 14HI-6 will help you select which servo options your system requires. Further details for each option are located in the sections indicated.

Table I-6. α Series servo package options

<i>Servo Option</i>	<i>Consider Selecting When</i>	<i>Catalog #</i>	<i>Section #</i>
Motor Holding Brake	The system design includes an axis that must hold its position when power is removed.	Motor option (see p. I-3 for motor catalog #)	2.3
IP67 Sealing	Enables the motor to meet IEC standards for protection from solid objects and water.	Motor option (see p. I-3 for motor catalog #)	4.1
Absolute Encoder Battery Packs	Avoids having to re-reference the position when power is restored to the control.	IC800ABK001	4.2
AC Line Filters	200—240 VAC is already available to the control cabinet and no transformer is used. Line filters reduce harmonic noise into the servo power supply.	5.4 kW, 3-phase: ZA81L-0001-0083#3C 10.5 kW, 3-phase: ZA81L-0001-0101#C	6.2
Prefinished Cables	The cable lengths available are appropriate for your application.	Refer to the “Cable Connection” table on p. I-43	7.2
External Discharge Resistor	The internal regenerative discharge resistor is insufficient for the application. If required, the regen resistor must be ordered separately.	16 Ohm 200 Watt: ZA06B-6089-H500 16 Ohm 800 Watt: ZA06B-6089-H713 8 Ohm 800 Watt: ZA06B-6089-H711	6.6

4.1 IP67 Sealing Option on α Series Servo Motors

Most of the α Series servo motors can be ordered with IP67 Sealing. Motors with the IP67 Sealing meet the IEC standards regarding protection from solid objects and water, as described below:

Standard IP6x: Protection from Solid Objects

- Protected against solid objects greater than 1 mm thickness or diameter
- Dust tight. "No ingress of dust."

Standard IPx7: Protection from Water

- Protected against dripping water, rate equivalent to 3–5 mm of rain per minute
- Protected against splashing water from any direction
- Protected from harmful damage due to water jets, according to the following test:
 - Spray from all angles of 12.5 liters/minute (3.3 gal/min)
 - Nozzle diameter = 6.3 mm (0.248 in)
 - Pressure = 30 kN/m² (0.3 bar)
 - Distance = 3 m (118 in)
 - Duration = 3 minutes
- Protected from harmful Protected against the effects of immersion, according to the following test:
 - Surface of the water level shall be at least 150 mm (5.9 in) above the highest point of the machine
 - Lowest point of the machine must be at least 1 m (39.4 in) below the surface of the water
 - Duration of the test must be at least 30 minutes
 - Water temperature must not differ from that of the machine by more than 5° C

For more information, refer to CEI/IEC 34–5; 1991 and *Servo and Spindle Motors Exposed to Liquids* (GFK-1046).

4.2 Absolute Encoder Battery Packs

All α Series servo motors feature a built-in serial encoder that can be used in either incremental or absolute mode. To utilize the absolute capability, an optional encoder battery pack (IC800ABK001) must be installed. This pack makes the encoder's position information non-volatile so that the machine does not need to be re-referenced to a home position every time power is restored to the servo system.

The Absolute Encoder Battery Kit (IC800ABK001) contains the following:

- One battery holder (ZA06B-6050-K060)
- Four D-cell, alkaline batteries (ZA98L-0031-0005)

One kit provides battery backup for up to four absolute encoders. A two-meter-long cable (Z44C741863-001) must be ordered separately for each servo axis connected to the battery pack. Kit components cannot be ordered separately.

The battery pack is panel-mounted and requires a cutout in the mounting surface. Mounting dimensions and terminal designations are shown below:

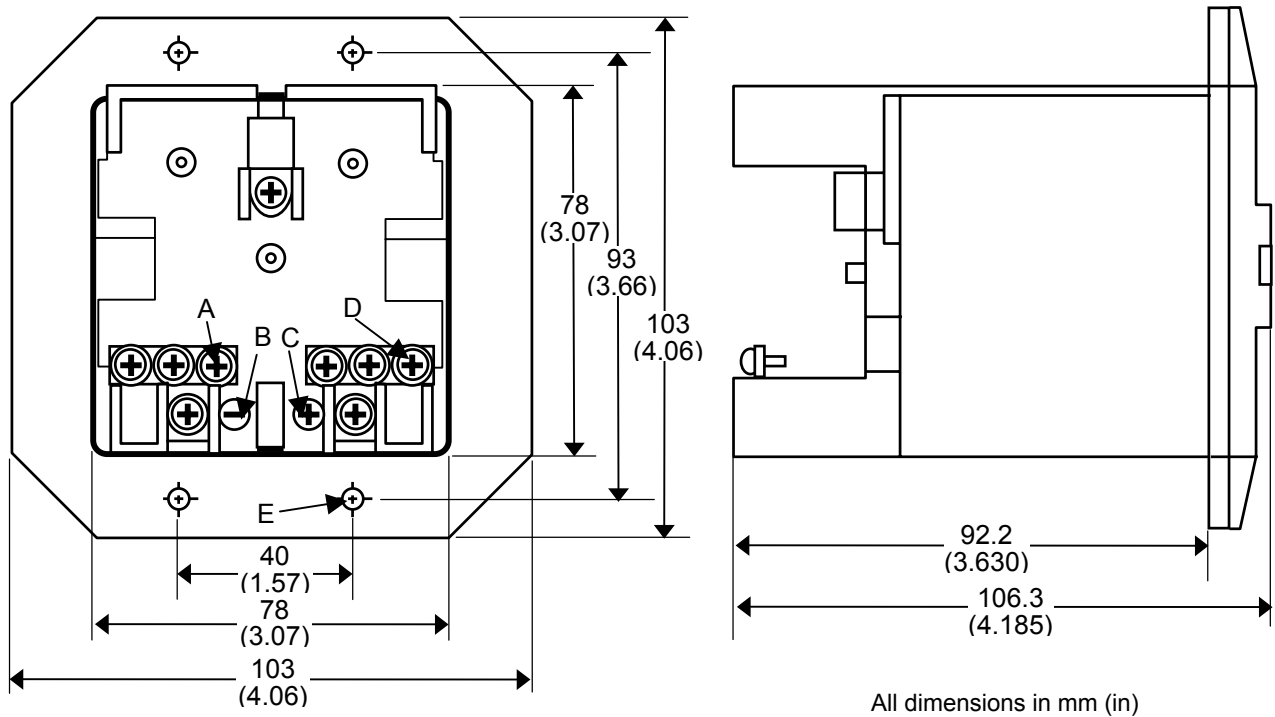

A	3-M3 negative terminal
B	Negative terminal indication
C	Positive terminal indication
D	3-M3 positive terminal
E	4- \varnothing 4.3 (0.169) mounting holes

- Note:** Current drain (per encoder) from battery:
- 20 μ A with amplifier power ON
 - 200 μ A with amplifier power OFF

Figure I-4. Absolute encoder battery pack

Section 5: Installation Guidelines

This section includes environmental requirements, motor and amplifier dimension drawings and information on ensuring noise protection and selecting a ground fault interrupter.

5.1 Motor Environmental Requirements

The servo motor must be installed in a location that satisfies the following environmental conditions:

Table I-7. Servo amplifier environmental conditions

Condition	Description
Ambient temperature	The ambient temperature should be -10°C to 40°C. When operating the machine at a temperature higher than 40°C (55°C max), it is necessary to derate the output power so that the motor's temperature rating is not exceeded.
Vibration	When installed in a machine, the vibration applied to the motor must not exceed 5G.
Altitude	No more than 1,000 m (3,300 ft) above sea level.
Drip-Proof Environment	The motors have a drip-proof structure that complies with IP65 of the IEC standard. Optional IP67 Sealing, available on most α Series servo motors, offers further protection from liquids (see Section 4.1 for more details). Nevertheless, to ensure long-term performance, the motor surface should be protected from solvents, lubricants, and fluid spray. A cover should be used when there is a possibility of wetting the motor surface. Also, to prevent fluid from being led to the motor through the cable, put a drip loop in the cable when the motor is mounted. Finally, turn the motor connector sideways or downward as far as possible. If the cable connector will be subjected to moisture, it is recommended that an R class or waterproof plug be used.

For additional information, see *Servo and Spindle Motors Exposed to Liquids*, GFK-1046.

5.2 Servo Amplifier Environmental Requirements

The servo amplifier must be installed in a location that satisfies the environmental conditions identified in Table 8 below.

Table I-8. Servo amplifier environmental conditions

Condition	Description
Ambient temperature	0°C to 55°C (operating). -20°C to 60°C (storage and transportation).
Temperature fluctuation	Within 1.1°C/min.
Humidity	30% to 95% RH (no condensation).
Altitude	No more than 1000 m (3,300 ft) above sea level.
Vibration	No more than 0.5 G during operation.
Atmosphere	The circuitry and heat sink must not be exposed to any corrosive and conductive vapor or liquid.

The amplifier must be installed in a cabinet that protects it from contaminants such as dust, coolant, organic solvents, acid, corrosive gas, and salt. Adequate protection must also be provided for applications where the amplifier could be exposed to radiation, such as microwave, ultraviolet, laser light, or x-rays.

Servo Products Specification Guide

To adequately protect the amplifier, you must ensure that:

- Contaminants such as dust and coolant, cannot enter through the air inlet or outlet.
- The flow of cooling air is not obstructed.
- The amplifier can be accessed for inspection.
- The amplifier can be disassembled for maintenance and later reinstalled.
- There is sufficient separation between the power and signal lines to avoid interference. Noise protection should be provided.

5.3 α SVU Series servo amplifier heat Dissipation

To determine the heat generated by an α Series SVU amplifier with a particular motor, use the table that follows. The α SVU Series amplifiers are mounted with their heat sink extending through a panel cut out in the control enclosure. This design eliminates most of the heat dissipation inside the control cabinet.

Table I-9. Servo amplifier heat dissipation

<i>Motor Model</i>	<i>Amplifier Model</i>	<i>Total Dissipation</i>	<i>Dissipation Inside Cabinet</i>
α 6/3000	α SVU1-80	73 W	38 W
α 12/3000	α SVU1-80	106 W	47 W
α 22/2000	α SVU1-80	127 W	54 W
α 30/3000	α SVU1-130	228 W	71 W
α 40/2000 w/ Fan	α SVU1-130	276 W	81 W

The following notes apply to the heat values:

- The heat dissipation values are worst case values when motors are run at their continuous output ratings.
- If the heat sink of the amplifier is installed outside the cabinet or if a separate regenerative resistor is installed outside the cabinet, it is unnecessary to add the heat generated by the regenerative resistor to the total heat generated by the cabinet. If the heat sink of a built-in or separate regenerative resistor is installed inside the cabinet, it is necessary to add the heat generated by the regenerative resistor to the heat generated by the cabinet. See Section 6.6 for more information.

5.4 α Series Motor Dimensions

$\alpha 6/3000$

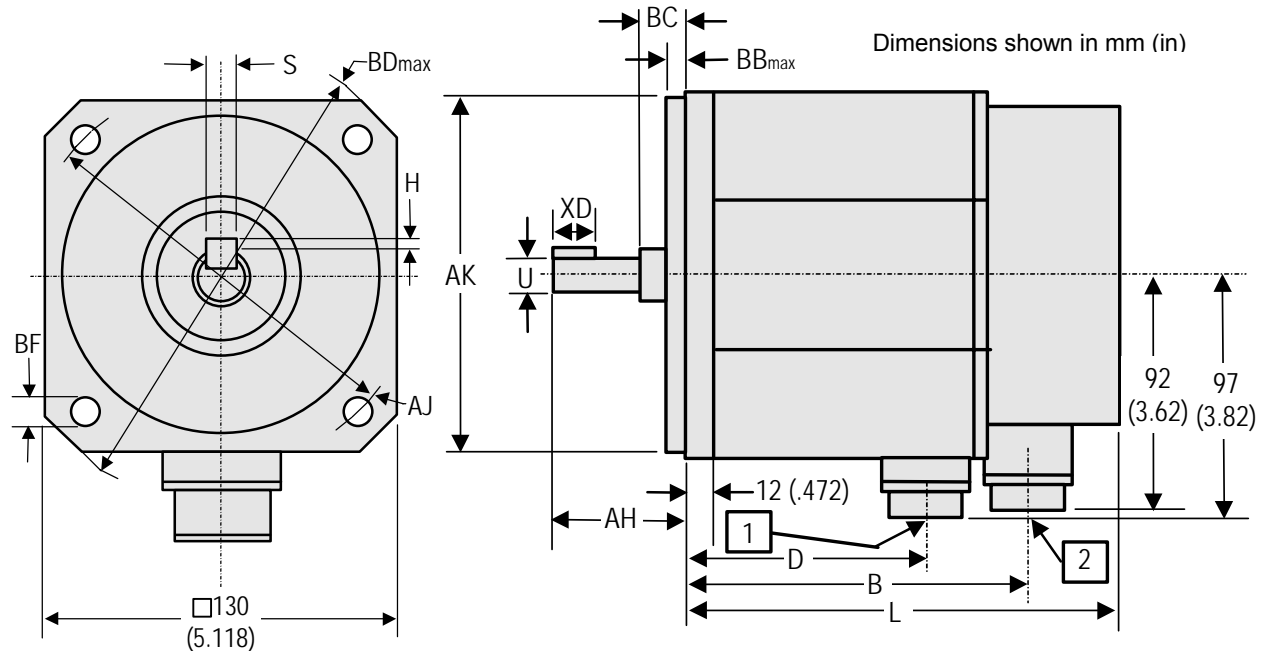

Dim.	MOTOR
	$\alpha 6/3000$
S	$6^{+0}_{-0.030}$ mm (0.2362/0.235 in)
H	$2.5^{+0}_{-0.013}$ (0.0984/0.0933)
BD	165 (6.496)
AJ (dia)	145 (5.709)
BF (dia)	9 (0.354)

Dim.	MOTOR
	$\alpha 6/3000$
BB	6 mm (.236 in)
XD	36 (1.417)
AK	$110^{+0}_{-0.035}$ (4.331/4.329)
U	$19^{+0}_{-0.013}$ (0.7480/0.7475)
BC	15 ± 0.5 (0.610/0.571)
AH	55 (2.165)
D	176 (6.93)
B	221 (8.70)
L	259 (10.20)

Connector	Description
1	Motor AC Power Connector
2	Motor Encoder Feedback Connector

NOTES

1. See the α Connection section (0) for more information about motor cables.
2. Shaft diameter runout = 0.02 mm max (0.00079 in).
3. Flange surface runout = 0.06 mm max (0.00236 in).
4. Rabbet diameter eccentricity = 0.02 mm max (0.00079 in).
5. Maximum radial load for output shaft is 70 kgf (31.8 lb).

Figure I-5. $\alpha 6/3000$ motor, front and side views

α6/3000 with Brake, Side View

(Front view same as α6/3000 without brake)

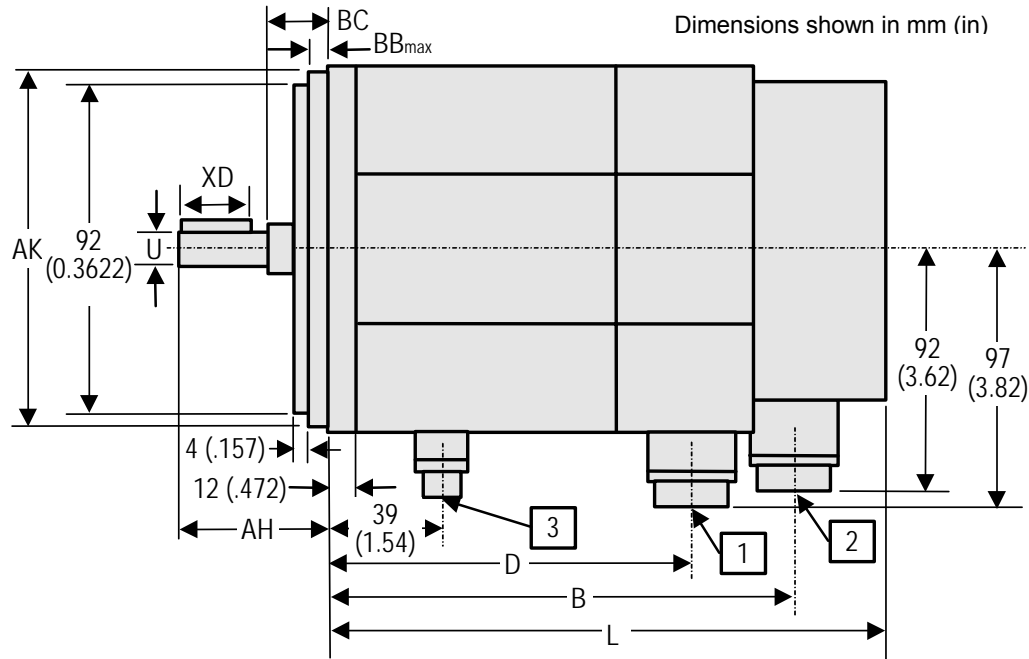

Dim.	MOTOR
	α6/3000 w/ brake
BB	6 mm (0.236 in)
XD	36 (1.917)
AK	110 ⁺⁰ _{-0.035} (4.331/4.329)
U	19 ⁺⁰ _{-0.013} (0.7480/0.7475)
BC	221 (8.70)
AH	55 (2.165)
D	225 (8.858)
B	270 (10.63)
L	309 (12.17)

Connector	Description
1	Motor AC Power Connector
2	Motor Encoder Feedback Connector
3	Brake Connector

NOTES

1. See the α Connection section (0) for more information about motor cables.
2. Shaft diameter runout = 0.02 mm max (0.00079 in).
3. Flange surface runout = 0.06 mm max (0.00236 in).
4. Rabbet diameter eccentricity = 0.04 mm max (0.00157 in).
5. Maximum radial load for output shaft is 70 kgf (31.8 lb).

Figure I-6. α 6/3000 motor with brake, side view

α12/3000, α22/2000, and α30/3000, Front View

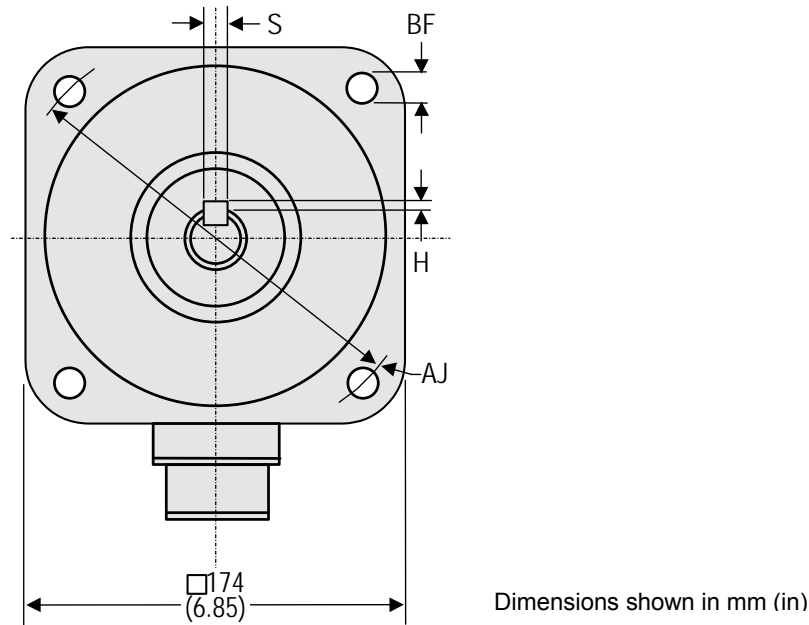

Dim.	MOTOR		
	α12/2000	α22/2000	α30/3000
S	10 ⁺⁰ _{-0.036} mm (0.3937/0.3923 in)	10 ⁺⁰ _{-0.036} mm (0.3937/0.3923 in)	10 ⁺⁰ _{-0.036} mm (0.3937/0.3923 in)
H	3 ⁺⁰ _{-0.30} (0.1181/0.1063)	3 ⁺⁰ _{-0.30} (0.1181/0.1063)	3 ⁺⁰ _{-0.30} (0.1181/0.1063)
BF	13.5 (0.532)	13.5 (0.532)	13.5 (0.532)
AJ	200 (7.874)	200 (7.874)	200 (7.874)

NOTES FOR ALL VIEWS (see page 16 for side view and page 17 for side view with brake)

1. See the α Connection section (Section 7.2) for more information about motor cables.
2. Shaft diameter runout = 0.05 mm max (0.00197 in).
3. Flange surface runout = 0.10 mm max (0.00394 in).
4. Rabbet diameter eccentricity = 0.07 mm (0.00276 in).
5. Maximum radial load for output shaft is 450 kgf (204 lb).
6. Taps for eyebolts are M8 by 15 mm (.591 in) deep; eyebolts are not attached.

Figure I-7. α 12/3000, α22/2000, and α30/3000 motors, front view

α12/3000, α22/2000, and α30/3000, Side View

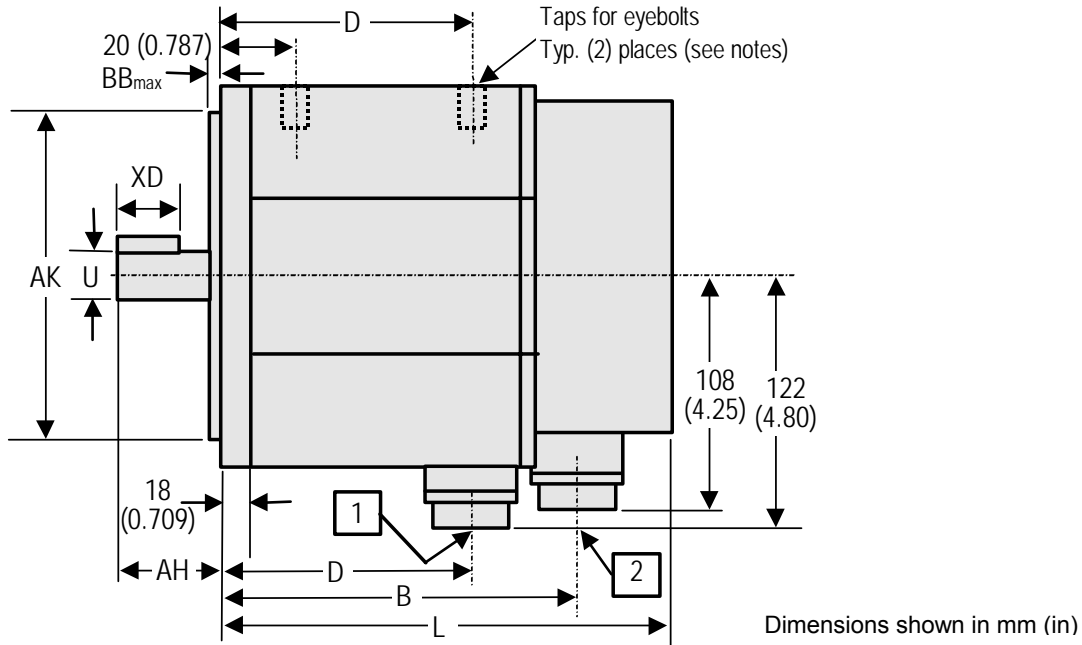

Dimen.	MOTOR		
	α12/2000	α22/2000	α30/3000
BB	3.2 mm (0.126 in)	3.2 mm (0.126 in)	3.2 mm (0.126 in)
XD	70 (2.756)	70 (2.756)	70 (2.756)
AK	114.3 ⁺⁰ _{-0.025} (4.50/4.499)	114.3 ⁺⁰ _{-0.025} (4.50/4.499)	114.3 ⁺⁰ _{-0.025} (4.50/4.499)
U	35 ^{+0.01} ₋₀ (1.3784/1.3779)	35 ^{+0.01} ₋₀ (1.3784/1.3779)	35 ^{+0.01} ₋₀ (1.3784/1.3779)
AH	79 (3.11)	79 (3.11)	79 (3.11)
D	166 (6.535)	240 (9.449)	314 (12.362)
B	215 (8.465)	289 (11.378)	363 (14.291)
L	240 (9.45)	314 (12.36)	388 (15.28)

Connector	Description
1	Motor AC Power Connector
2	Motor Encoder Feedback Connector

Figure I-8. α 12/3000, α22/2000, and α30/3000 motors, side view

Servo Products Specification Guide

α12/3000, α22/2000, and α30/3000 with Brake, Side View

(Front view same as α12/3000, α22/2000, and α30/3000 without brake; see also Notes on page I-15)

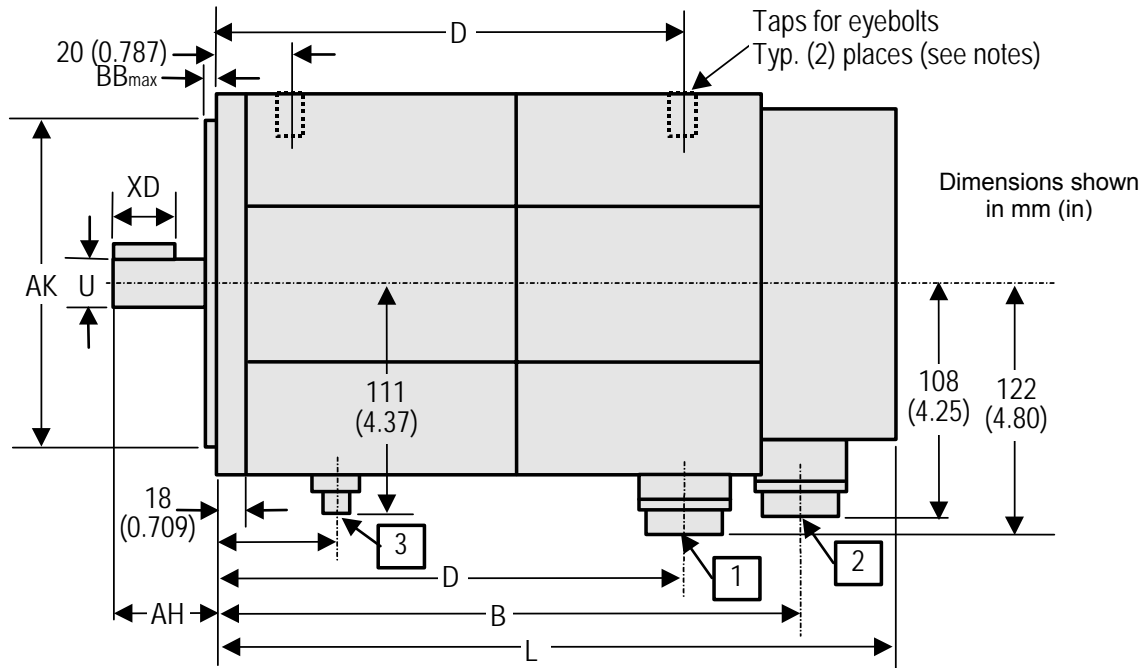

Dimension	MOTOR		
	α12/2000 w/brake	α22/2000 w/brake	α30/3000 w/brake
BB	3.2 mm (0.126 in)	3.2 mm (0.126 in)	3.2 mm (0.126 in)
XD	70 (2.756)	70 (2.756)	70 (2.756)
AK	114.3 ⁺⁰ _{-0.025} (4.50/4.499)	114.3 ⁺⁰ _{-0.025} (4.50/4.499)	114.3 ⁺⁰ _{-0.025} (4.50/4.499)
U	35 ^{+0.01} ₋₀ (1.3784/1.3779)	35 ^{+0.01} ₋₀ (1.3784/1.3779)	35 ^{+0.01} ₋₀ (1.3784/1.3779)
AH	79 (3.11)	79 (3.11)	79 (3.11)
D	238 (9.37)	312 (12.28)	386 (15.20)
B	287 (11.30)	361 (14.21)	435 (17.13)
L	312 (12.28)	386 (15.20)	460 (18.11)

Connector	Description
1	Motor AC Power Connector
2	Motor Encoder Feedback Connector
3	Brake Connector

Figure I-9. α 12/3000, α22/2000, and α30/3000 motors with brake, side view

α40/2000 with Fan, Front And Rear Views

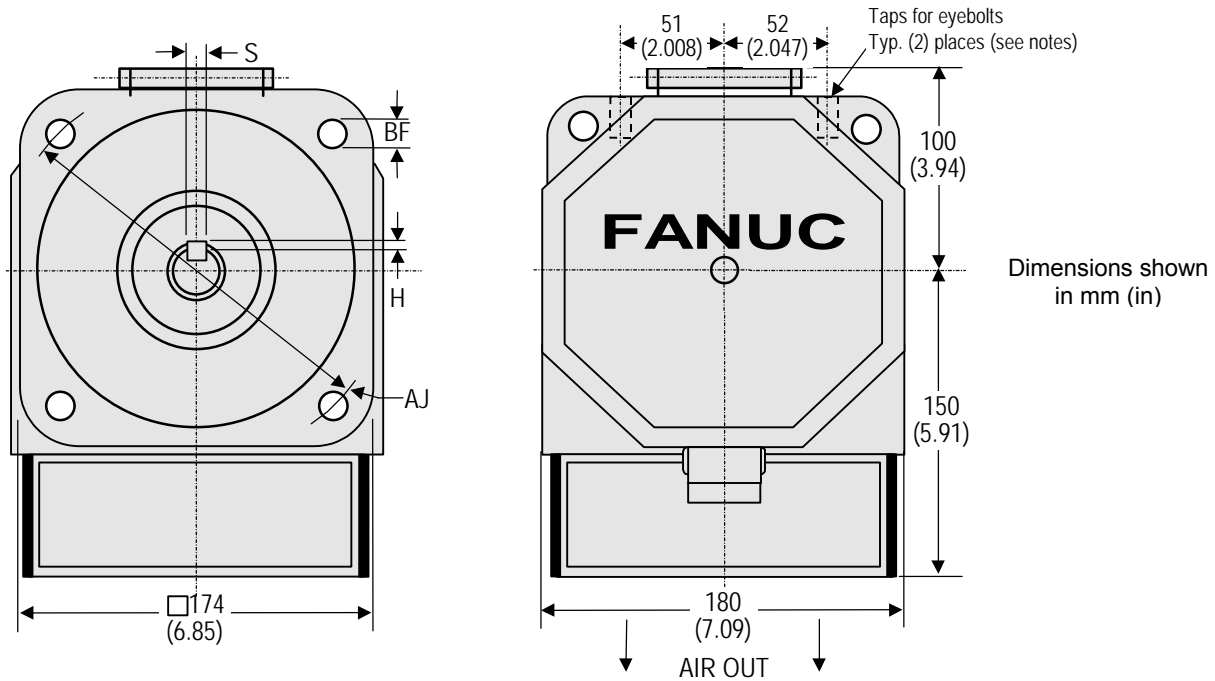

Dim.	MOTOR
	α40/2000 w/fan
S	10 ⁺⁰ _{-0.036} mm (0.3937/0.3923 in)
H	3 ⁺⁰ _{-0.30} (0.1181/0.1063)
BF (dia.)	13.5 mm (0.531 in)
AJ (dia.)	200 (7.874)

NOTES FOR ALL VIEWS (see pages 19 and 20 for top and side views)

1. See Section 7.2 for more information about motor cables.
2. Shaft diameter runout = 0.05 mm max (0.00197 in).
3. Flange surface runout = 10.10 max (0.00394 in).
4. Maximum radial load for output shaft is 450 kgf (990 lb).
5. Taps for eyebolts are M8 by 15 mm (.591 in) deep; eyebolts are not attached.
6. Rabbet diameter eccentricity = 0.07 mm max (0.00276 in).
7. Direction of air flow is downward only.

Figure I-10. α 40/2000 with fan, front and rear views

Servo Products Specification Guide

α 40/2000 with Fan, Top and Side Views

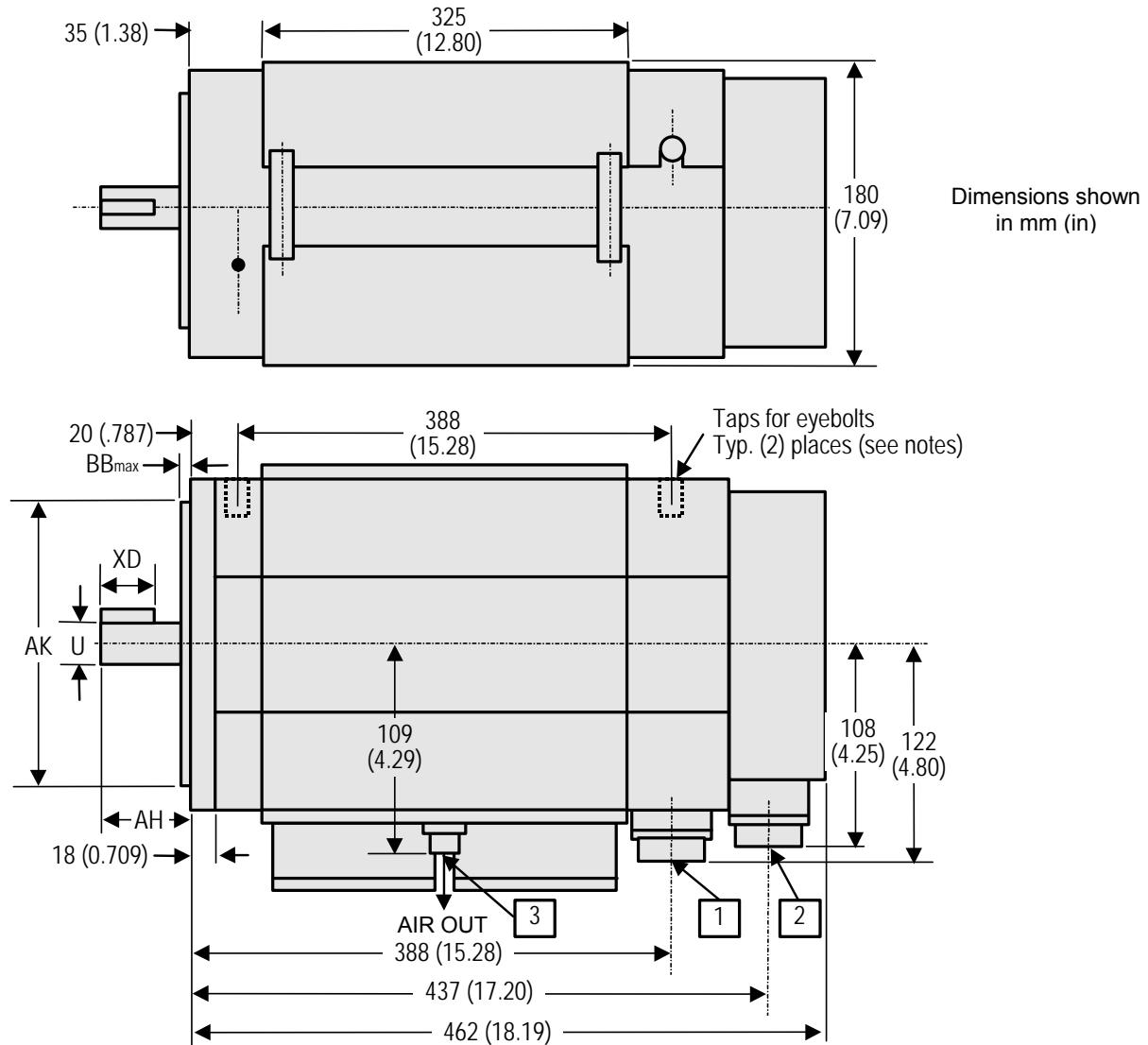

Dim.	MOTOR
	α 40/2000 w/fan
BB	3.2 mm (0.126 mm)
XD	70 (2.756)
AK	$114.3^{+0}_{-0.025}$ (4.50/4.499)
U	$35^{+0.01}_{-0}$ (1.3784/1.3779)
AH	79 (3.11)

Connector	Description
1	Motor AC Power Connector
2	Motor Encoder Feedback Connector
3	Fan Connector

Figure I-11. α 40/2000 motor with fan, top and side views

α40/2000 with Fan and Brake, Top and Side Views

(Front and rear views same as α40/2000 with fan and without brake)

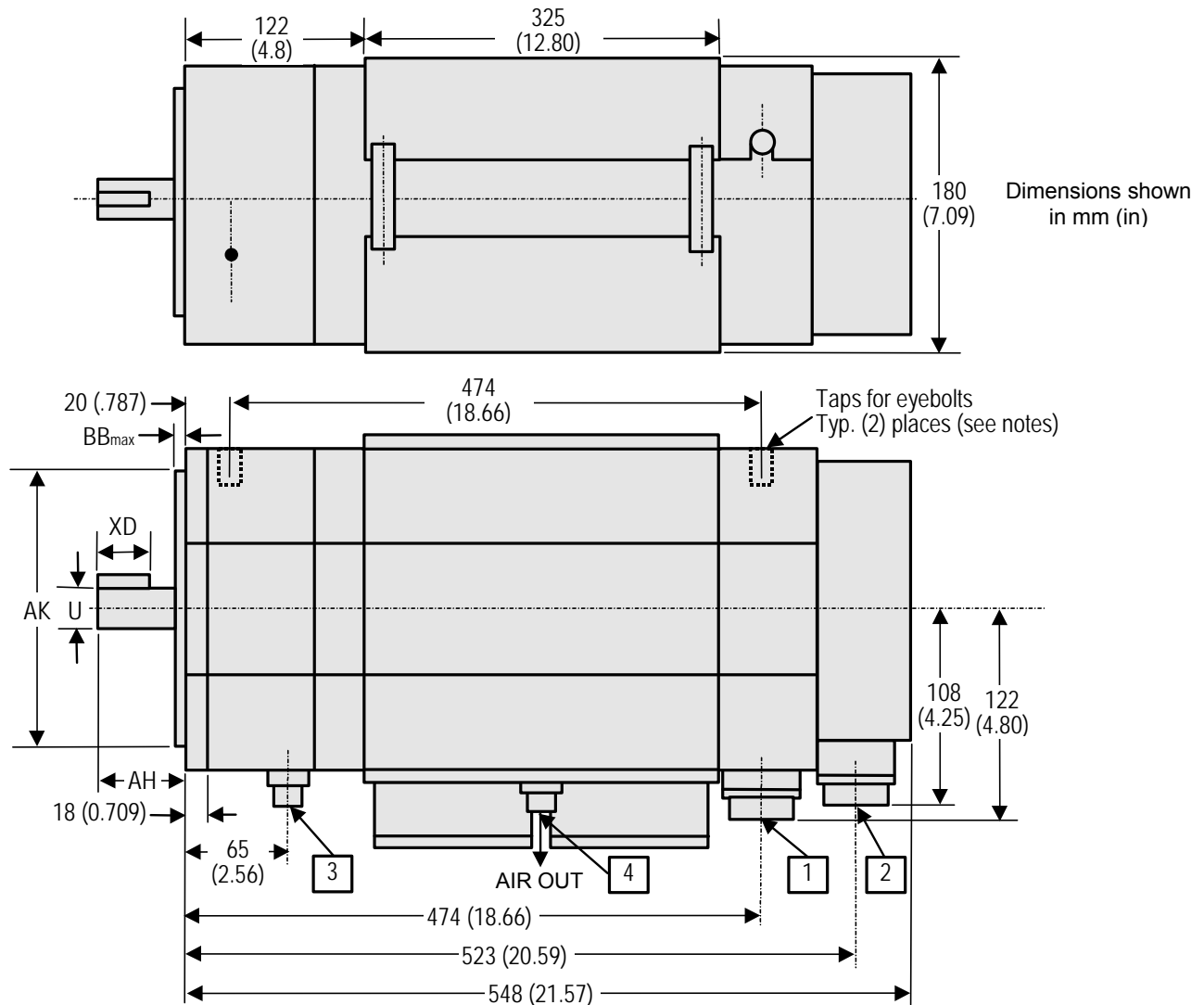

Dim.	MOTOR
	α40/2000 w/fan
BB	3.2 mm (0.126 in)
XD	70 (2.756)
AK	114.3 ⁺⁰ _{-0.025} (4.50/4.499)
U	35 ^{+0.01} ₋₀ (1.3784/1.3779)
AH	79 (3.11)

Connector	Description
1	Motor AC Power Connector
2	Motor Encoder Feedback Connector
3	Brake Connector
4	Fan Connector

Figure I-12. α 40/2000 motor with fan and brake, top and side views

5.5 Shaft Loading

The allowable load of the motor shaft is as follows:

Table I-10. Allowable motor shaft load

<i>Motor Model</i>	<i>Radial Load</i>	<i>Axial Load</i>	<i>Front Bearing Type</i>
α 6/3000	70 kg (31.8 lb)	20 kg (9.1 lb)	6205
α 12/3000, α 22/2000, α 30/3000, α 40/2000 w/ fan	450 kg (204 lb)	135 kg (61.4 lb)	6208

NOTES:

- The allowable radial load is the value when a load is applied to the shaft end. It indicates the total continuous force applied to the shaft in some methods of mounting (for example, belt tension) and the force by load torque (for example, moment/pulley radius).
- The belt tension is critical particularly when a timing belt is used. Belts that are too tight may cause breakage of the shaft or premature bearing failure. Belt tension must be controlled so as not to exceed the limits calculated from the permissible radial load indicated above.
- In some operating conditions, the pulley diameter or gear size needs to be checked. For example, when using the model α 6/3000 with a pulley/gear with a radius of 1.5 cm (2 in) or less, the radial load when 230 in-lb of peak torque is provided by the motor will exceed the 154 lb maximum rating. In the case of the timing belt, the belt tension is added to this value, making it necessary to support the shaft end.
- When using a timing belt, shaft failure or bearing overload can be minimized by positioning the pulley as close to the bearing as possible.
- Since a standard single row, deep-groove ball bearing is used for the motor bearing, a very large axial load cannot be used. Particularly when using a worm gear and a helical gear, it is necessary to provide another bearing to isolate the thrust load from the searing.
- The motor bearing is generally fixed with a C-snap ring, and there is a small play in the axial direction. When this play influences the positioning in the case of using a worm gear and a helical gear, for example, it is necessary to use an additional bearing support.

5.6 α SVU1 Series Amplifier and Panel Cutout Dimensions

The α SVU Series amplifiers are designed with a rear-mounted heat sink that extends through a hole in the mounting plate. This design eliminates most of the heat dissipation inside the control cabinet reducing the temperature rise in the cabinet and the load on cabinet cooling equipment.

This section contains front and side views as well as the panel cutout drawings for the SVU1-80 and SVU1-130 servo amplifier units.

α SVU1-80 and SVU1-130 Dimension Drawings

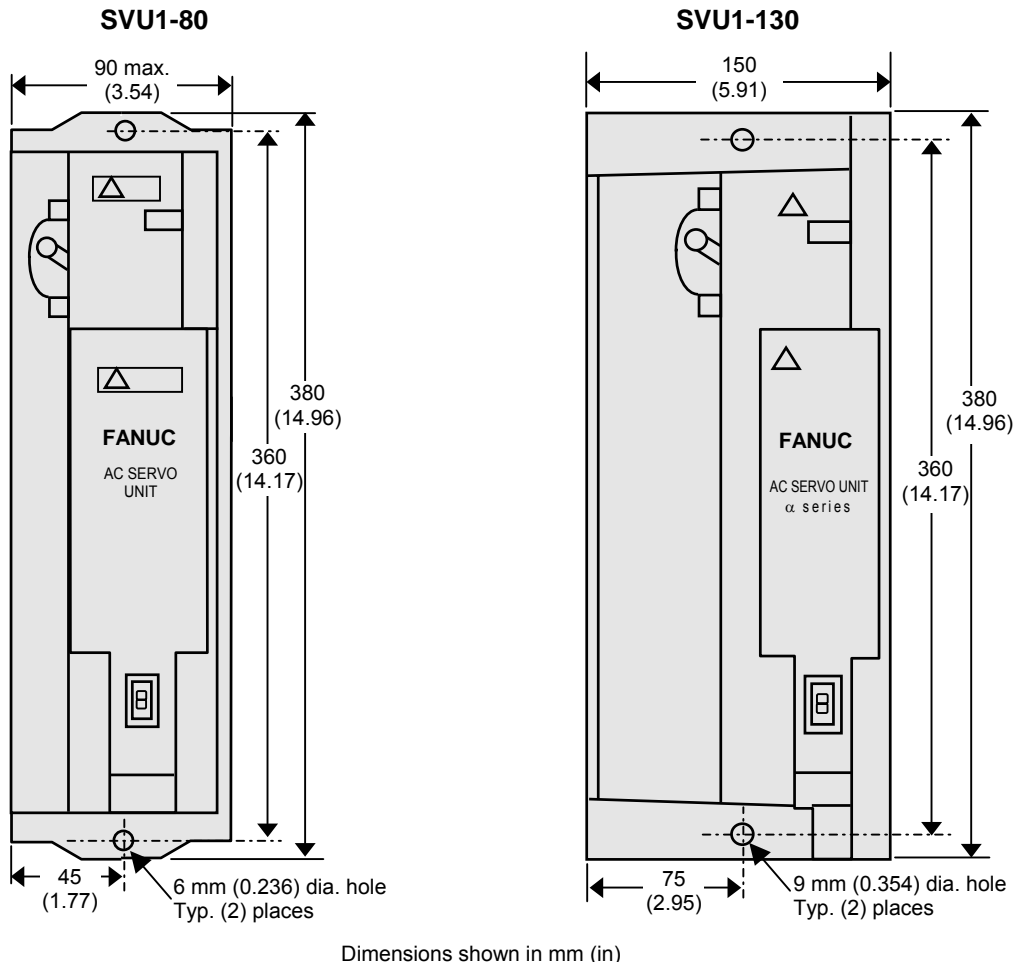
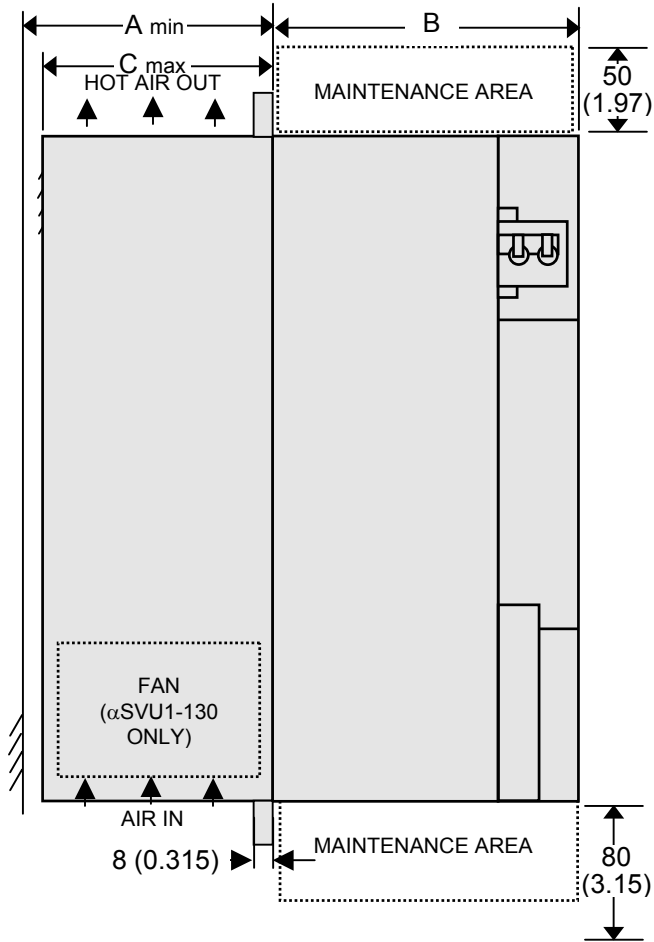

Figure I-13. Front view of α SVU1-80 and α SVU1-130 servo amplifiers

Servo Products Specification Guide



Dim.	SVU1-80	SVU1-130
A	135 mm (5.31 in)	135 mm (5.31 in)
B	165 (6.50)	175 (6.89)
C	120 (4.72)	130 (5.12)

Dimensions shown in mm (in)

Figure I-14. Side view of αSVU1-80 and αSVU1-130 servo amplifiers

NOTE

The α SVU Series amplifiers and regenerative discharge units have rear heat sink extensions designed to protrude through the customer's control cabinet. This design allows the amplifier's heat to be dissipated outside the control cabinet, reducing the load on enclosure cooling equipment. Panel cut out drawings are shown on the next page.

α SVU1-80 and SVU1-130 Panel Cutout Drawings

SVU1-80

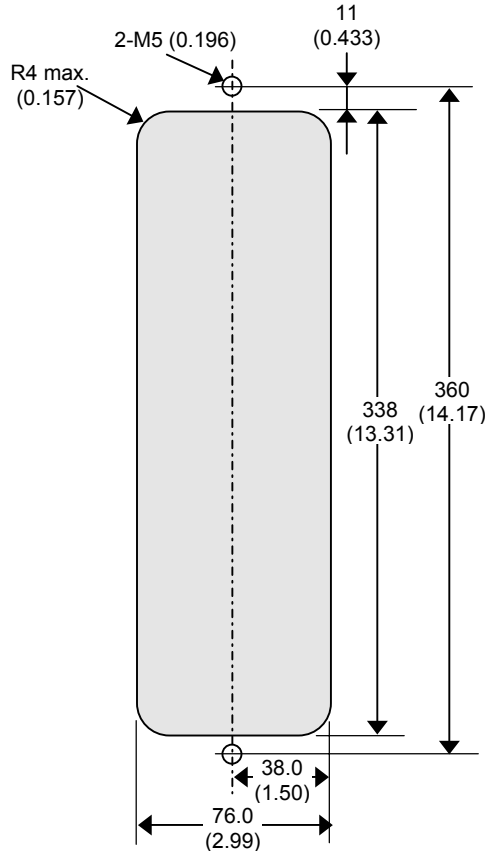

SVU1-130

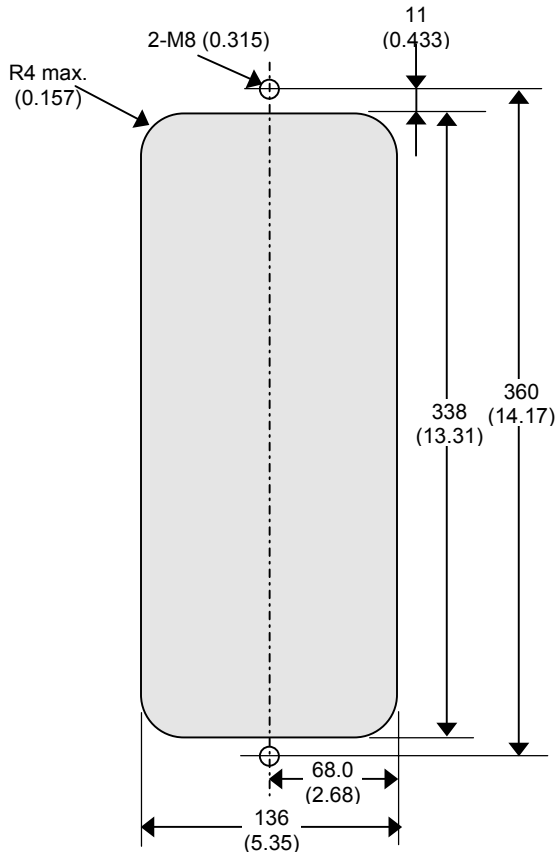

Dimensions shown in mm (in)

Figure I-15. Panel cut out drawings of *α* SVU1-80 and *α* SVU1-130 servo amplifiers

5.7 α SVU Series Switch Settings

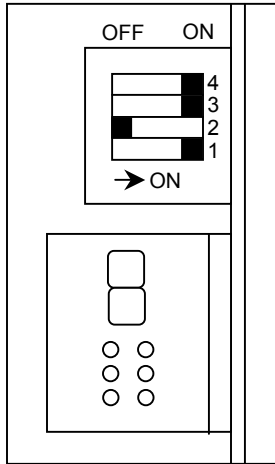

There are four channel switches located above the 7-segment LED and behind the terminal board cover on the front of the α Series servo amplifiers. These switches should be set as described below before use of the α SVU series servo amplifiers.

Figure I-16. α SVU Series channel switches

Positions:

The switches are sequentially numbered 1, 2, 3, and 4 with the one at the bottom as switch 1. The OFF position is on the left, and the ON position is on the right.

Switch 1 Setting:

Always set to ON.

Switch 2 Setting:

Always set to OFF for α SVU1 Series.

NOTE: If the switch 2 setting is incorrect, the VRDY OFF alarm may occur.

Switch 3 and 4 Setting:

The setting of these switches depends on the regenerative discharge resistance used:

Table I-11. Switch 3 and 4 setting for α SVU1 Series amplifiers

SVU1-80		
Regen. Discharge Unit	SW3	SW4
Built-in (100 W)	ON	ON
Separate ZA06B-6089-H500 (200 W)	ON	OFF
Separate ZA06B-6089-H713 (800 W)	OFF	OFF

SVU1-130		
Regen. Discharge Unit	SW3	SW4
Built-in (400 W)	ON	ON
Separate ZA06B-6089-H711 (800 W)	ON	OFF

5.8 Noise Protection

Separation of Signal and Power Lines

When routing signal and power lines, the signal lines must be separated from the power lines to ensure best noise immunity. Table I-12 below lists the types of cables used:

Table I-12. Servo amplifier signal line separation

Group	Signal	Action
A	Amplifier input power line, motor power line, MCC drive coil	Separate these cables from those of group B by bundling them separately* or by means of electromagnetic shielding**. Attach a noise preventer or suppressor, such as a spark arrester, to the MCC drive coil.
B	Cable connecting control unit with servo amplifier and serial encoder feedback cable	Separate these cables from those of group A by bundling them separately or by means of electromagnetic shielding**. In addition, shielding must be provided.

* The bundle of group A cables must be separated from the bundle of group B cables by at least 10 cm.

** Electromagnetic shielding involves shielding groups from each other by means of a grounded metal (steel) plate.

Grounding

A typical machine has three separate grounds:

- **Signal Ground:** Provides the reference potential (0 V) for the electrical signal system.
- **Frame Ground:** Ensures safety and shields external and internal noise.
- **System Ground:** Connects each unit and the inter-unit frame ground system to earth ground.

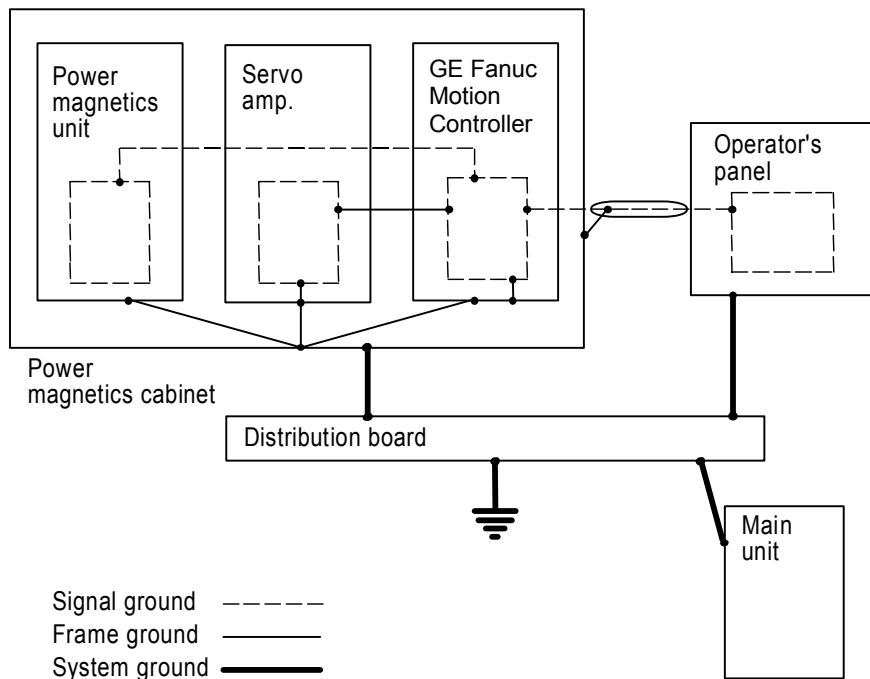

Figure I-17. Ground system

Servo Products Specification Guide

Notes on the ground system wiring for α SVU1 Series amplifiers:

- The ground resistance of the system ground must not exceed 100 ohms (Class-3 ground).
- System ground connection cables must have a sufficiently large cross-sectional area to enable them to safely carry the current that will arise in the event of a problem such as a short-circuit (in general, a cross-sectional area no less than that of the AC power line must be provided).
- The system ground connection cable must be integrated with the AC power line such that power cannot be supplied if the ground wire is disconnected.
- The motor frame must be referenced to earth ground with a class 3 (100 ohms or less) system ground. Use an ohmmeter to measure the resistance from the servomotor frame to a known earth ground rod or grid. The frame-to-ground resistance should be within 1 to 2 ohms.

In a high noise environment, installing a ground wire on the motor frame and routing it directly to the nearest available earth ground can improve noise immunity. Some servo motors have a tapped hole on the frame or a blind hole that can be tapped. For smaller motors, connect to the motor mounting bolts.

- The Motor Power cable should not be a shielded cable. If a custom built cable with shield was used for motor power, lift the shield connection at both ends of the cable. If a shield is attached, especially at the motor end, it acts as an antenna to couple noise into the encoder.
- The Motor Feedback cable should have the Z44B295864-001 Grounding Bar and one ZA99L-0035-001 Grounding Clamp per axis installed near the amplifier. Confirm that the grounding bar is referenced to earth ground with a class 3 (100 ohms or less) system ground. Use an ohmmeter to measure the resistance from the grounding bar frame to a known earth ground rod or grid. The frame to ground resistance should be within 1 to 2 ohms.

In a high noise environment, installing a ferrous bead on the feedback cable within a short distance of the amplifier connector can also improve noise immunity.

- Separation of Motor Power and Motor Feedback cables: Group A signals (Amplifier main AC power, Motor Power Cable and MCC drive coil) signals must be separated from Group B signals (Motor Feedback cable) by at least a 10cm distance. Do not tie Group A and B signals together with cable ties or wraps at any point. An alternative is to separate these two groups by means of a grounded metal (steel) plate.
- The MCC relay used to switch the three-phase AC main power to the amplifier should have an appropriate noise (spark arrester) on its drive coil.
- An AC line filter is recommended to suppress high frequency line noise on the amplifier main power lines. When an isolation transformer is used to convert AC main power to amplifier input power levels, the AC line filter is not required. GE Intelligent Platforms supplies an acceptable three-phase line filter sized for 5.4KW or 10.5KW especially for this purpose. This filtered AC main power should not be shared with other equipment in the panel, especially with devices such as inverter drives or motor starters that have high power consumption.
- Amplifier Chassis Ground must be referenced to earth ground with a class 3 (100 ohm or less) system ground. Use an ohmmeter to measure the resistance from the amplifier frame to a known earth ground rod or grid. A tapped and threaded hole is provided on the amplifier frame for this purpose.
- AC Main PE Ground is supplied in accordance to local code practices and may vary, depending on AC power distribution in the facility. In general the PE ground should be referenced to an earth ground and not indicate common mode voltage to the instrumentation earth ground.

5.9 Command Cable Grounding

The motion controller cables that require shielding should be clamped by the method shown below. This cable clamp treatment provides both cable support (strain relief) and proper grounding of the shield. To ensure stable system operation, the cable clamp method is recommended. Partially peel back the cable sheath to expose the shield. Push the clamp (ZA99L-0035-0001) over the exposed shield and insert the clamp hooks into slots on the grounding bar (Z44B295864-001). Tighten the clamp to secure cable and complete the ground connection. The grounding bar must be attached to a low impedance earth ground.

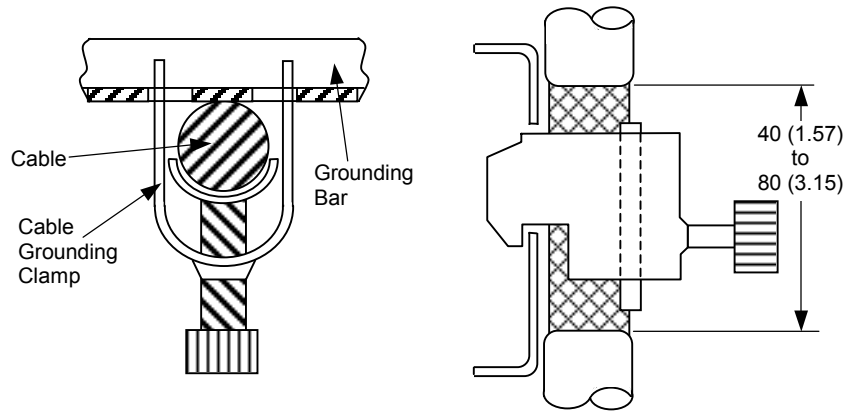

Figure I-18. Cable grounding clamp detail

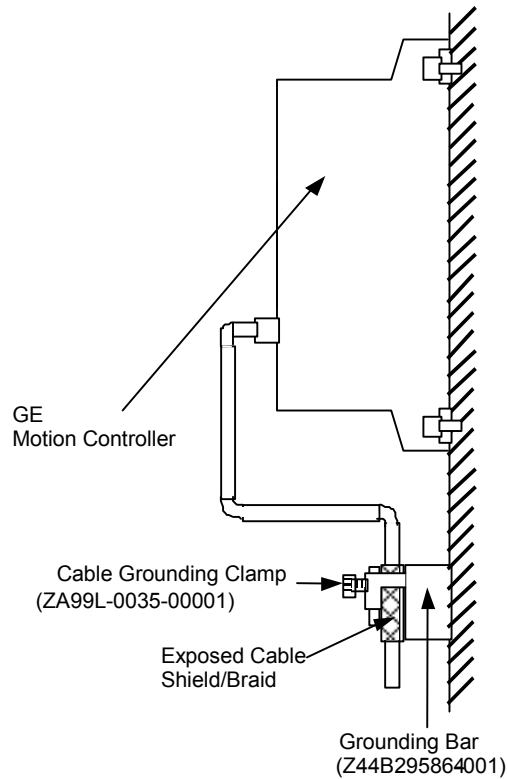

Figure I-19. Command cable shield grounding system

5.10 Selecting a Ground Fault Interrupter

The α Series servo amplifier drives a motor by means of the transistor-based PWM inverter method, in which a high-frequency leakage current flows to ground through the stray capacitance of the motor windings, power cable, and amplifier. A ground fault interrupter or leakage-protection relay, which is installed on the power supply side, can malfunction if such a leakage current should flow. Therefore, you should select an inverter-compatible ground fault interrupter capable of handling the approximate leakage currents shown below to protect against the occurrence of this malfunction:

- **$\alpha 6/3000$** : choose a 1.8 mA commercial frequency component.
- **$\alpha 12/3000$, $\alpha 22/2000$** : choose a 2.0 mA commercial frequency component.
- **$\alpha 30/3000$, $\alpha 40/2000$** : choose a 2.5 mA commercial frequency component.

Section 6: α Servo System Power Requirements

This section provides information about AC amplifier power as well as the discharge of regenerative power.

6.1 Power Line Protection

A circuit breaker, electromagnetic contactor and AC line filter or transformer should be installed as part of your α Series Servo system. GE Intelligent Platforms provides the AC line filter as an option. The transformer, circuit breaker, and electromagnetic contactor, however, are user-supplied components. In European countries where power sources are 380 to 400 VAC and neutral grounded, it is necessary to install a transformer.

The same incoming AC control components can be used to provide power to multiple amplifiers, as long as the components are rated for the current and power drawn by the sum of all of the amplifiers.

6.2 AC Line Filter

An AC line filter is recommended to suppress the influences of high-frequency input line noise on the drive power supply. When an isolation-type power transformer is used because a power supply voltage within the specified range is not available, an AC line filter is not required.

If two or more servo amplifiers are connected to one AC line filter, the total continuous output rating of all connected servo amplifiers should be kept below the continuous output rating of the AC line filter. The continuous output rating for the various servos are shown below.

Table I-13. α servo motor continuous output rating

Motor	Cont. Output Rating
α 6/3000	1.4 kW
α 12/3000	2.8 kW
α 22/2000	3.8 kW
α 30/3000	4.8 kW
α 40/2000 with fan	7.3 kW

If your installation must be EMC compliant, verify that the use of an AC line filter fully satisfies the EMC requirements. You may need to select and install a user-supplied noise filter to meet EMC requirements.

GE Intelligent Platforms offers the AC line filters that can be used with the Alpha Series amplifiers:

- 5.4 kW, 3-phase (ZA81L-0001-0083#3C)
- 10.5 kW, 3-phase (ZA81L-0001-0101#C)

Servo Products Specification Guide

Table I-14. AC line filter specifications

Catalog Number	ZA81L-0001-0083#3C	ZA81L-0001-0101#C	ZA81L-0001-0168	ZA81L-0001-0169
Continuous rated current	24A	44A	24A	41A
Max. continuous rated power	5.4kW	10.5kW	5.4kW	10.5kW
Heat dissipation	20W	70W	20W	70W
Weight	1.1 kg (2.4 lb)	3.0 kg (6.6 lb)	1.1 kg (2.4 lb)	3.0 kg (6.6 lb)

The dimensions of the AC line filters are as follows

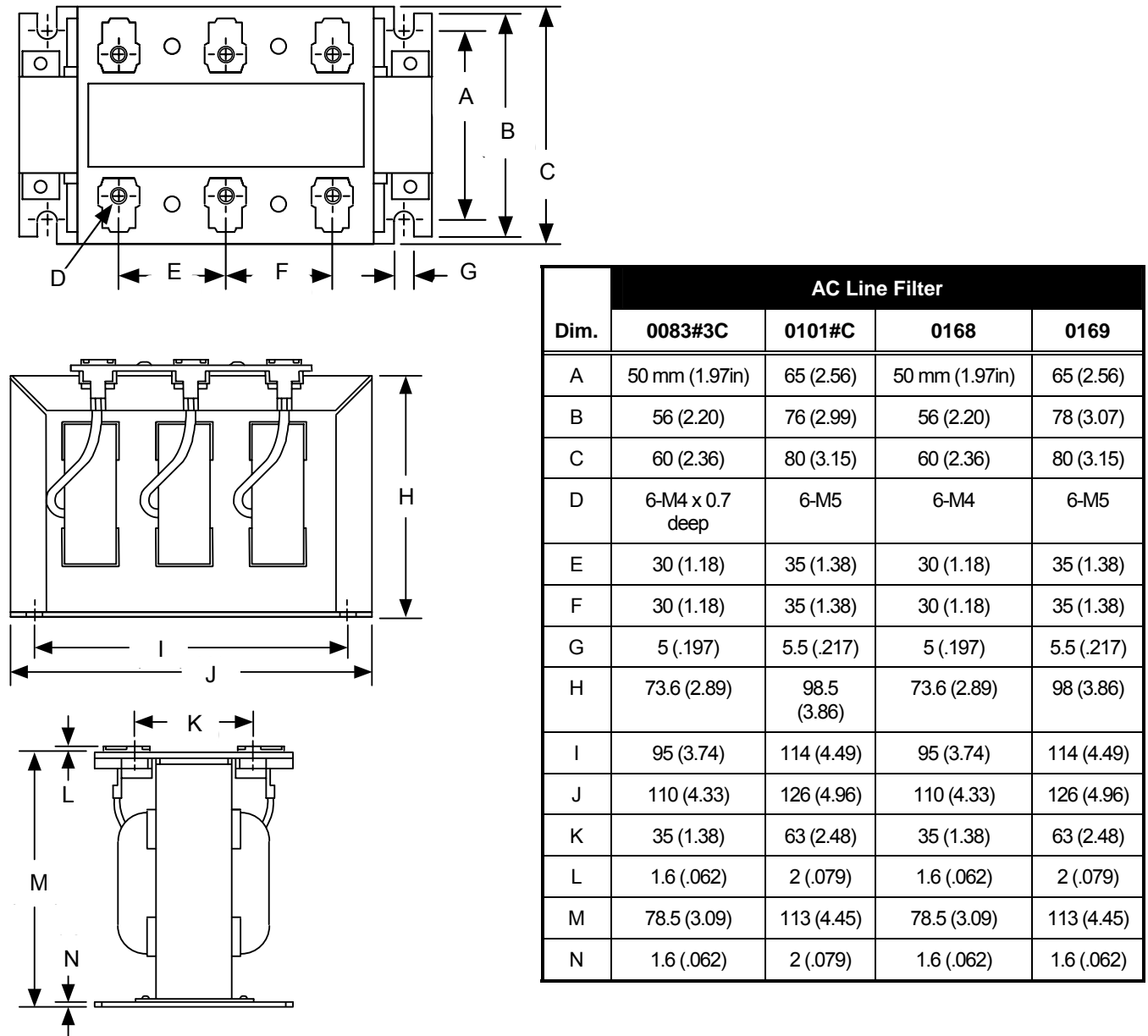

Figure I-20. AC line filter dimension drawing

6.3 Circuit Breaker Selection

To provide proper protection for the amplifier, use a circuit breaker rated at no more than 20 Amps (10A for VDE 1601 compliance for CE marking). Table I-15 will help you select the appropriate circuit breaker for your motion application.

Table I-15. Currents drawn at continuous rated output

Motor	Input Current 3-phase*
α 6/3000	6 A (rms)
α 12/3000	11 A (rms)
α 22/2000	15 A (rms)
α 30/3000	21 A (rms)
α 40/2000	29 A (rms)

NOTE

When multiple amplifiers are connected to a single circuit breaker, select a breaker by multiplying the sum of the currents listed in Table 65HI-15 by 0.6.*

During rapid motor acceleration, a current that is three times the continuous rating flows. Select a circuit breaker that does not trip when a current that is three times the continuous rating flows for two seconds.

*This factor attempts to compensate for applications where all axes are not demanding full power at the same time. For applications where all axes are running continuously or with high duty cycles, this factor must be increased to 1.

6.4 Electromagnetic Contactor (MCC) Rating

To prepare for incoming AC power, you must also select and install an appropriate electromagnetic contactor (MCC), based on the peak currents for the motors in your system. A contactor is typically required on systems approved to display the CE marking (Machinery Directive). When multiple amplifiers are connected to a single circuit breaker, select a breaker based on the sum of the currents in Table I-15.

6.5 Incoming AC Power

The α SVU Series servo amplifiers require a three-phase AC input for main bus power and a single-phase AC input for control power. Two terminals of the three-phase input (L1 and L2) are connected with the terminals for the single-phase input by jumper bars on terminal board T1 at the factory. If you want to separate the two power supplies, remove the jumper bars. The power requirements for these supplies are shown below:

Table I-16. AC and control power

Specification	Description
Voltage: 3-phase	200 VAC to 240 VAC
Frequency	50 Hz, 60Hz \pm 2 Hz
Voltage fluctuation during acceleration/deceleration	7% or less

Table I-17. Control power current

Amplifier Model	Control Power Current
α SVU1-80	150 mA
α SVU1-130	300 mA

AC Power Ratings

The power supply rating required when using multiple servo motors can be determined by summing the requirements of the individual motors.

The power supply ratings listed in Table I-18 are sufficient as continuous ratings. Note, however, that servo motor acceleration causes a current to momentarily flow that is approximately three times the continuous flow rating.

When the power is turned on, a surge current of about 37A (when 264VAC is applied) flows for 20 msec.

Table I-18. Three-phase power supply ratings

Motor	Power Supply Rating	Current @ 230 VAC
α 6/3000	2.2 kVA	6 A
α 12/3000	4.3 kVA	11 A
α 22/2000	5.9 kVA	15 A
α 30/3000	8.2 kVA	21 A
α 40/2000 with fan	11.3 kVA	29 A

6.6 Discharging Regenerative Energy

Regenerative energy is normally created in applications with a high load inertia or frequent acceleration and deceleration. When decelerating a load, the stored kinetic energy of the load causes generator action in the motor causing energy to be returned to the α Series amplifier.

The α SVU amplifiers have a regenerative discharge resistor built in to dissipate this energy. For light loads, low acceleration rates, or low speed machines, the amplifier may be able to handle the regenerated energy. Some applications may require the assistance of a separately mounted external regenerative discharge unit. Vertical axes with no counter balance may generate excessive regenerative energy. These units comply with VDE 0160, European Safety Standards for CE marking.

Three separate regenerative discharge units are available for the α SVU Series amplifiers:

- 16 Ω , 200 W (ZA06B-6089-H500) for the SVU1-80 (weight of 2.2 Kg [4.8 lb])
- 16 Ω , 800 W (ZA06B-6089-H713) for the SVU1-80 (weight of 5 Kg [11 lb])
- 8 Ω , 800 W (ZA06B-6089-H711) for the SVU1-130 (weight of 5 Kg [11 lb])

Calculations to determine if a separate regenerative discharge unit is required are shown in “Calculating the Average Regenerative Energy.”

If the regenerative discharge unit overheats, a built-in thermostat is tripped, the external overheat alarm is issued, and the motor is stopped. If an external regenerative discharge unit is required, a separate unit must be installed for each amplifier. This component cannot be daisy-chained. The dimensions for these units are shown in on page I-38. Connections for cables K7 and K8 are shown on p. I-52 of this document.

Calculating the Average Regenerative Energy

Use the following calculation to determine the average regenerative power that will be released in your application (ambient temperature is assumed not to exceed 55°C). Based on the calculations, a separate regenerative discharge unit may be required. If this is the case, select either the 200 W or 800 W regenerative discharge unit as appropriate for the amplifier model. The watt rating of the selected unit must exceed the average calculated regenerative power.

$$\begin{array}{r}
 \text{Average} \\
 \text{Amount of} \\
 \text{Regenerative} \\
 \text{Discharge (W)}
 \end{array}
 =
 \begin{array}{r}
 \text{Rotational Power Released} \\
 \text{During Deceleration (P}_1\text{)} \\
 \text{(STEP 1)}
 \end{array}
 -
 \begin{array}{r}
 \text{Power} \\
 \text{Consumed} \\
 \text{through Axis} \\
 \text{Friction (P}_2\text{)} \\
 \text{(STEP 2)}
 \end{array}
 +
 \begin{array}{r}
 \text{Vertical Power} \\
 \text{Released During} \\
 \text{Downward} \\
 \text{Motion (P}_3\text{)} \\
 \text{(STEP 3)}
 \end{array}$$

Servo Products Specification Guide

STEP 1—Rotational power released during deceleration (P_1)

$$P_1 = (6.19 \times 10^{-4}) \times (J_m + J_L) \times \omega_m^2 / F \text{ watts}$$

where:

F	Deceleration duty (Example: deceleration once per 5 second cycle, F=5)	(sec)
J_m	Motor rotor inertia $\alpha 6/3000 = 0.0174$ $\alpha 12/3000 = 0.0555$ $\alpha 22/2000 = 0.1041$ $\alpha 30/3000 = 0.1475$ $\alpha 40/2000 = 0.1996$	(lb-in-s ²)
J_L	Load inertia converted to motor shaft inertia	(lb-in-s ²)
ω_m	Maximum motor speed at time of deceleration	(rpm)

STEP 2—Power consumed through axis friction (P_2)

$$P_2 = (5.91 \times 10^{-3}) \times t_a \times \omega_m \times T_L / F \text{ Watts}$$

where:

ω_m	Maximum motor speed at time of deceleration	(rpm)
t_a	Worst case/deceleration time (shortest time)	(sec)
T_L	Machine friction torque	(in-lb)
F	Deceleration duty	(sec)

STEP 3—Vertical power released during downward motion (P_3)

(this term applies only for vertical axis operation)

$$P_3 = (1.182 \times 10^{-2}) \times T_h \times \omega_m \times \frac{D}{100} \text{ Watts}$$

where:

ω_m	Motor speed during rapid traverse	(rpm)
T_h	Upward supporting torque applied by the motor during downward motion	(sec)
D	Duty cycle of downward operation (Note: The maximum value of D is 50%)	(%)

Servo Products Specification Guide

STEP 4—Determine if a separate regenerative discharge unit is required

When the average regenerative power produced never exceeds the values indicated in Table 75HI-19, a separate regenerative discharge unit is **NOT** required:

$$\text{Average Regenerative Power} = P_1 - P_2 + P_3$$

Table I-19. Maximum allowable regenerative energy for amplifiers

Amplifier	Max. Allowable Regen. Power	Used with Motors
α SVU1-80	100 watts	α 6/3000, α 12/3000, α 22/2000
α SVU1-130	400 watts	α 30/3000, α 40/2000 w/fan

If the average regenerative power exceeds the value for the amplifier, only then is a separate regenerative discharge unit required. Select a unit from Table 77HI-20 that exceeds the calculated power value.

Table I-20. Regenerative discharge capacity

Amplifier Model	Unit	Catalog #	No Air Flow	Air Velocity 2m/sec	Air Velocity 4m/sec
α SVU1-80	16 Ω , 200 W	ZA06B-6089-H500	200 W (as shipped)	400 W*	600 W*
α SVU1-130	8 Ω , 800 W	ZA06B-6089-H711	Forced cooling fan is installed		800 W
α SVU1-80	16 Ω , 800 W	ZA06B-6089-H713	Forced cooling fan is installed		800 W

*GE Intelligent Platforms does not supply a cooling fan for this unit. These values are supplied for reference only (customer-supplied fan).

Servo Products Specification Guide

EXAMPLE:

Assume a vertical axis using an α 12/3000 motor ($J_m = 0.0555 \text{ lb-in-s}^2$) that decelerates once every 4 seconds ($F = 4$) for 0.10 seconds (t_a) from a maximum speed of 2500 rpm (ω_m). The machine load inertia reflected to the motor shaft (J_L) is 0.05 lb-in-s^2 . The torque (max) required to support the load during a downward move (T_h) is 100 in-lb, and the downward motion is 20% of the cycle (D). Axis friction (T_L) is 35 in-lb.

STEP 1:

$$\begin{aligned} P_1 = \text{Rotational Power} &= (6.19 \times 10^{-4}) \times (0.0555 + 0.05) \times 2000^2/4 \\ &= 65.3 \text{ Watts} \end{aligned}$$

STEP 2:

$$\begin{aligned} P_2 = \text{Friction Power} &= (5.91 \times 10^{-3}) \times 0.10 \times 2000 \times 35/4 \\ &= 10.3 \text{ Watts} \end{aligned}$$

STEP 3:

$$P_3 = \text{Vertical Power} = (1.182 \times 10^{-2}) \times 100 \times 2000 \times \frac{20}{100} = 472.8 \text{ Watts}$$

STEP 4:

$$\begin{aligned} \text{Average Power} &= P_1 - P_2 + P_3 \\ &= 65.3 - 10.3 + 472.8 \\ &= 527.8 \text{ Watts} \end{aligned}$$

(Note the large value associated with the non-counterbalanced vertical load)

Since this value is larger than the 100 W internal capacity of the α SVU1-80 amplifier used with this motor, a separate regenerative discharge unit is required. The ZA06B-6089-H713 unit is adequate since its 800 W rating exceeds the 539.1 W average for the application. With a customer-supplied fan with at least a 4 m/sec flow rate, the ZA06B-6089-H500 unit could also be used.

Regenerative Discharge Unit Dimensions

The separate regenerative discharge units are designed with a rear-mounted heat sink that extends through a hole in the mounting plate. This design eliminates most of the heat inside the control cabinet. This section contains the dimensions for the units, and Section 0 shows the necessary panel cutouts to properly mount the units in an enclosure.

ZA06B-6089-H500 (200 W) for the α SVU1-80

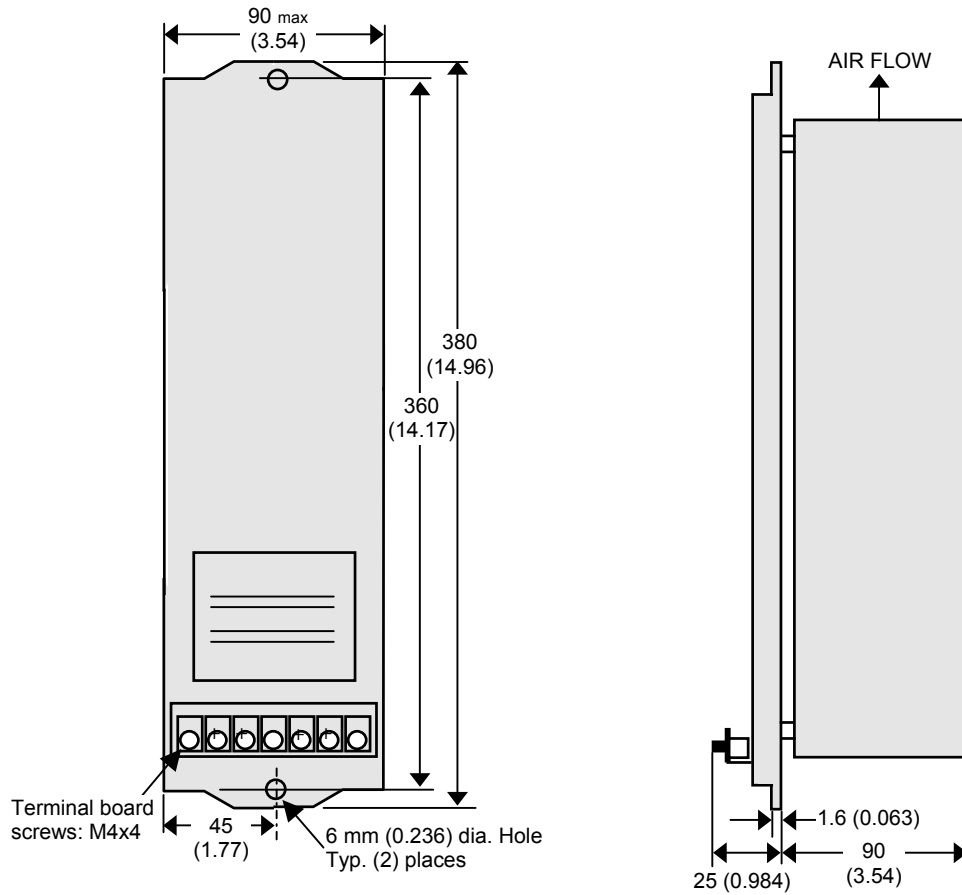

Figure I-21. 200 W Regenerative discharge unit (ZA06B-6089-H500), front, side, and end views

Servo Products Specification Guide

ZA06B-6089-H711 (800 W) for the α SVU1-130 and ZA06B-6089-H713 (800W) for the α SVU1-80

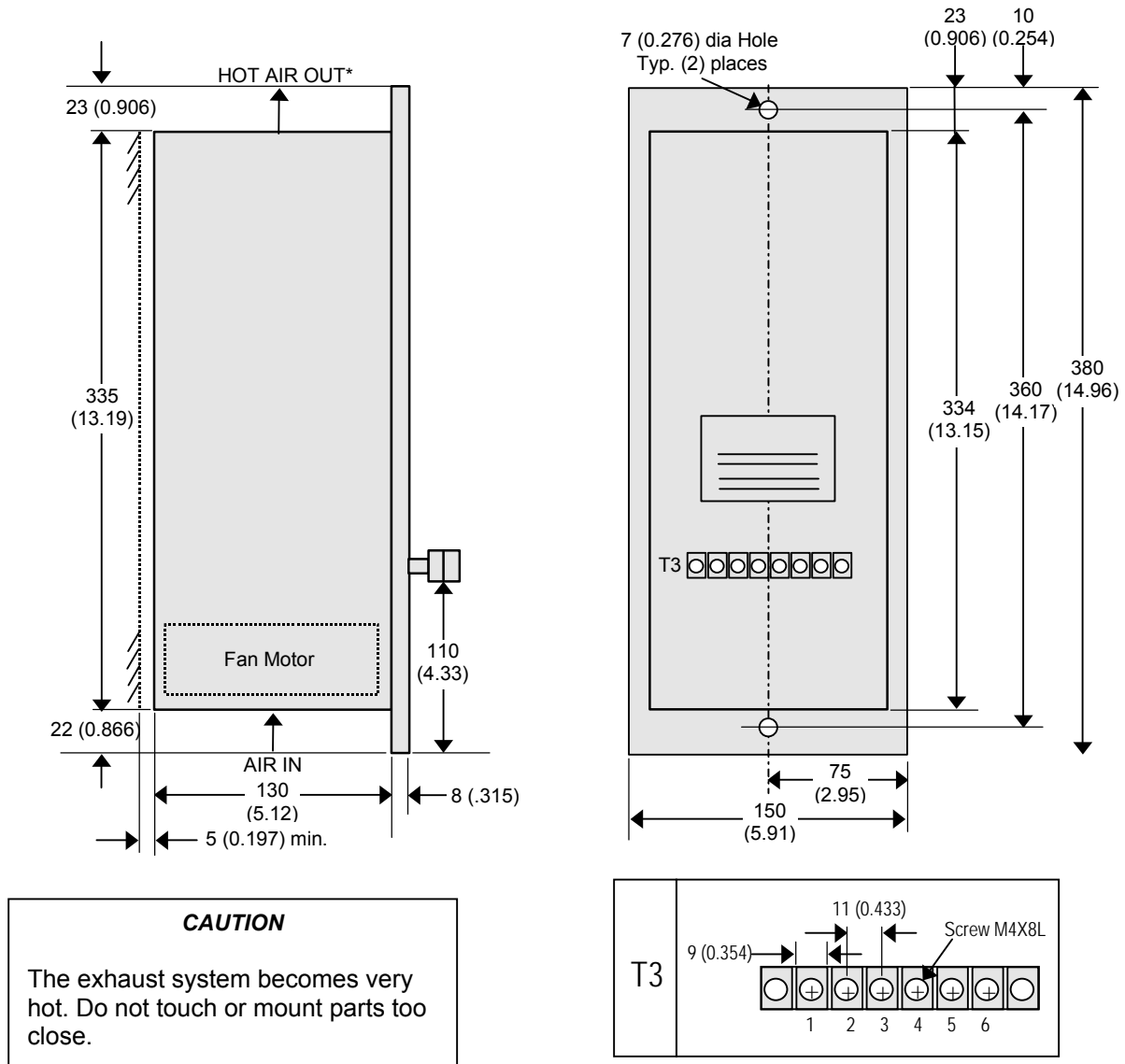

Figure I- 22. 800 W Regenerative discharge unit (ZA06B-6089-H711, ZA06B-6089-H713), front, side, and end views and T3 terminal detail

Regenerative Discharge Unit Panel Cutout Dimensions

The panel cutouts necessary to mount the separate regenerative discharge units are shown below.

ZA06B-6089-H500 (200 W) for the α SVU1-80

ZA06B-6089-H711 (800 W) for the α SVU1-130

ZA06B-6089-H713 (800 W) for the α SVU1-80

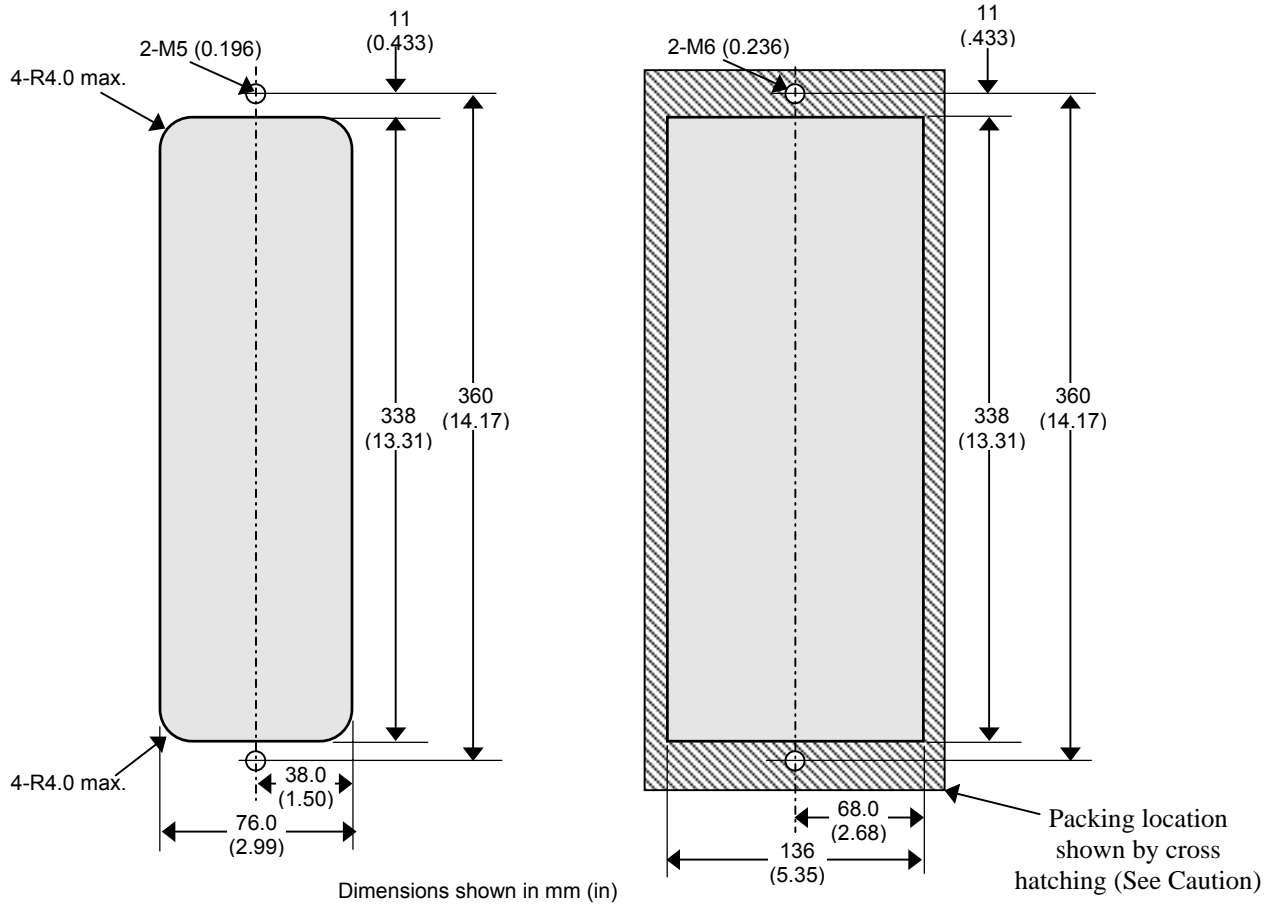

CAUTION:
 Attach packing (acrylonitrile-butadiene rubber or soft NBR) around the cutout to keep out oil and dust.

Figure I-23. Regenerative discharge unit panel cutout dimensions

Section 7: α Servo System Connection

7.1 α SVU1 Amplifier Connections

Power terminations are connected to the α SVU amplifiers on Terminal Board T1 located on the front of the amplifier. The terminals are shielded by a hinged cover that includes a convenient label indicating the terminal designations, as shown in Figure 83HI-24. Terminals are M4 screws and will accept stripped wire, spring spade, or ring terminals.

α SVU1-80
(ZA06B-6089-H105)

α SVU1-130
(ZA06B-6089-H106)

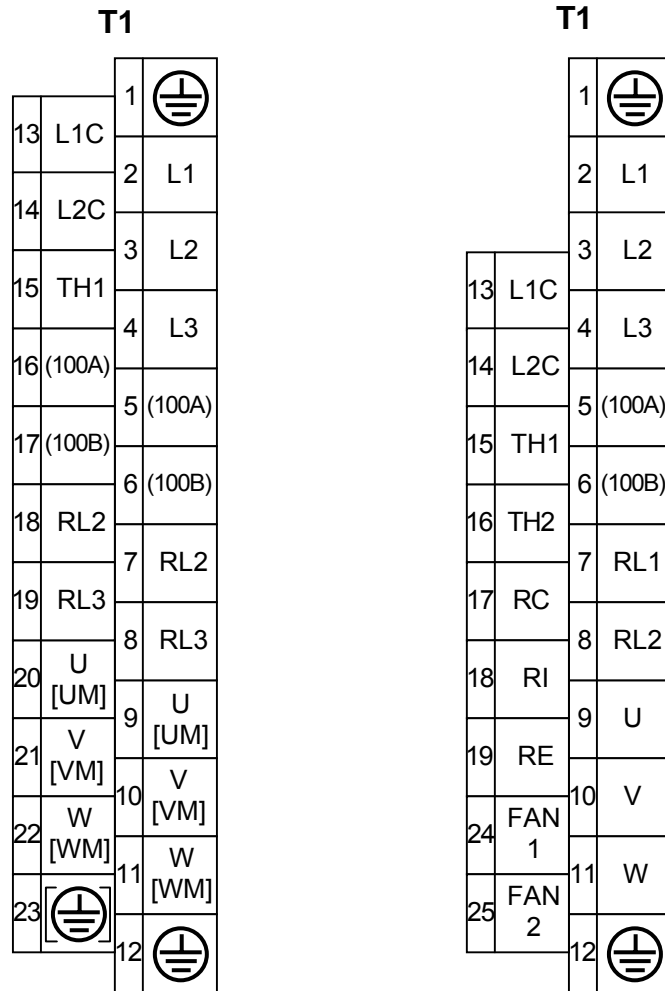

NOTE

5 and 6 on terminal board T1 are not used with the α SVU1 Series.

Figure I-24. α SVU amplifier terminal designations

Servo Products Specification Guide

Signal and control cables are interfaced to the amplifiers using connectors on the bottom of the unit. Location and designation of each connector is shown in Figure 86HI-25.

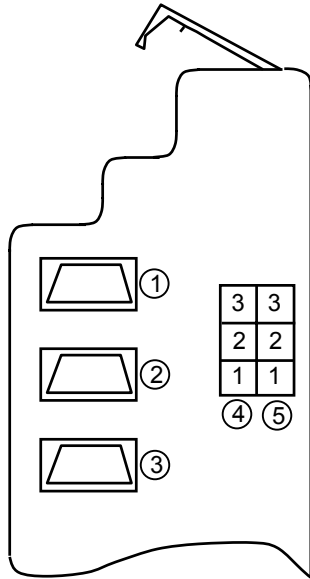

#	Connector Description	Connector Label	Remarks	See Section 7.4
①	Connector for GE Intelligent Platforms Motion Controller or CNC Interface	JS1B	N/A	K1 cable
②	Connector for Serial Encoder	JF1	N/A	K2 cable
③	Connector for Serial Encoder Battery	JA4	N/A	K9 cable
④	Connector for 24V power supply (connector keyed for Y position)	CX3	pin 1 pin 3	K10 cable
⑤	Connector for E-Stop input signal (connector keyed for X position)	CX4	pin 2; ESP pin 3; 24V	K5 cable

Figure I-25. Bottom view of α SVU amplifier

7.2 α System Connections

When planning your system, it is important to determine how the different parts of the system connect together. Cable reference numbers K1 through K15 on the α Servo Connection Diagram in Section 7.3 and in Table 90HI-22 indicate the required and optional system connections.

The α Series motor and amplifier connectors required for the system are available from GE Intelligent Platforms.

GE Intelligent Platforms supplies connectors to allow you to manufacture cables to the specific length required by your system design. GE Intelligent Platforms also offers finished cables as options for many connections. See the Cable Connections chart that follows for more information.

An external contactor (MCC) connector (ZA06B-6089-K201) and E-Stop connector (ZA02B-0120-K321) are shipped with each α Series servo amplifier package.

Table I-21. Available motor cable connectors for α Servo systems

Part Number	Description
Z44A730464-G18	Motor Power Connector Kit, α 6/3000
Z44A730464-G20	Motor Power Connector Kit, α 12/3000 and α 22/2000
Z44A730464-G21	Motor Power Connector Kit, α 30/3000 and α 40/2000
ZA06B-6050-K115	Motor Encoder Connector Kit, α 6/3000
Z44A730464-G24	Motor Encoder Connector Kit, α 12/3000, α 22/2000, α 30/3000, and α 40/2000
Z44A730464-G26	Motor Brake Connector Kit, all α Series motors

Servo Products Specification Guide

Table I-22. Cable Connections

Ref.	Connects	Prefinished Cable Part Number	Connection Type	When Required
K1	DSM302 to Amplifier (JS1B)	IC800CBL001 (1m) IC800CBL002 (3m)	Servo Command Signal	always
K1	All Other Controllers to Amplifier (JS1B)	IC800CBL003 (2m)	Servo Command Signal	always
K2	Built in Serial Encoder to Amplifier (JF1)	CF3A-2MPB-0140-AZ	Motor Encoder Feedback	always
K3	AC Power Supply to Amplifier	N/A	3-Phase Servo Power	always
K4	Amplifier to Motor (Prefinished cables include separate cable to connect motor frame ground to customer's earth ground.)	IC800CBL061 (α 6/3000) [14m] IC800CBL062 (α 12/3000, α 22/2000) [14m] CP5A-1MPB-0140-AZB (α 30/3000, α 40/2000) [14m]	Motor Power	always
K5	Amplifier E-stop contact (CX4) to machine E-stop contact	N/A	Emergency Stop	always
K6	AC Control Power Supply to Amplifier	N/A	Amplifier Control Power	always
K7	Amplifier to Regenerative Discharge Unit	N/A	Separate Regenerative Discharge Unit	in some cases ¹
K8	Regenerative Discharge Unit Over Temperature Switch to Amplifier	N/A	Separate Regenerative Discharge Unit	in some cases ¹
K9	Amplifier (JA4) to Encoder Backup Battery Unit	44C741863-001	Absolute Encoder Battery	with battery option ²
K10	Control to MCC Coil Connector (CX3) on Amplifier	N/A	Emergency Stop/Power Enable	control-dependent; consult your control documentation
K11	Amplifier to Regenerative Discharge Unit Cooling Fan	N/A	Separate Regenerative Discharge Unit Fan Supply Cable	in some cases ¹
K12	90 VDC Brake Power Supply to Motor Brake	Z44C742238-004 (14m)	Motor Brake Power	with brake option
K13	Motor Cooling Fan to Fan Power Supply	Z44C742238-004 (14m)	Motor Fan Power	α 40/2000 with fan only

¹ See the Discharging Regenerative Energy section in Section 6.6

² Prefinished cable is provided as a part of a battery pack option

7.3 α SERIES Servo Connection Diagram

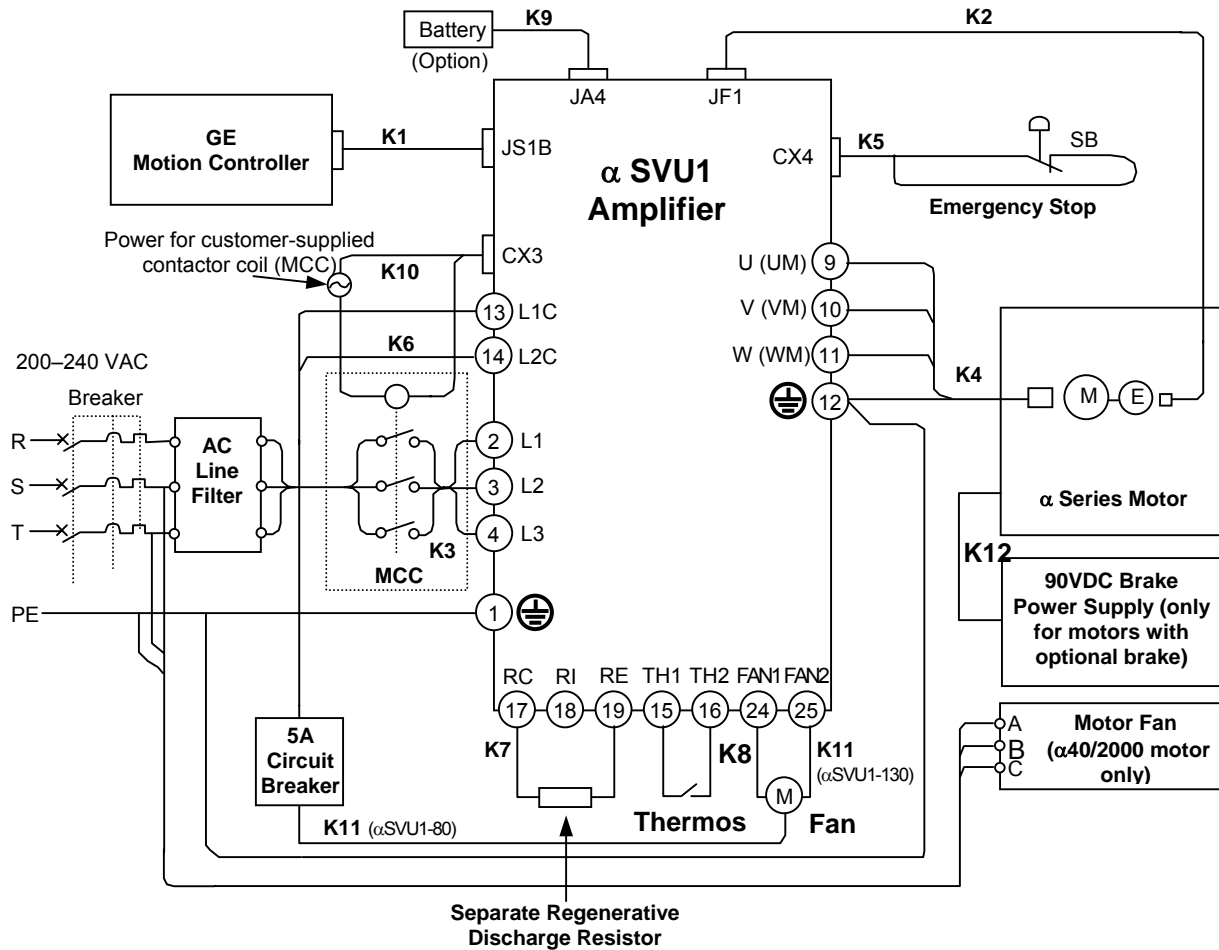

NOTES

- An AC line filter is recommended (unless an isolation transformer is provided) to reduce the effect of harmonic noises to the power supply. Two or more α SVU amplifiers can be connected to one AC line filter if its power capacity is not exceeded.
- RC and RI were connected to each other through a jumper bar at the factory. If a separate regenerative discharge unit will be used, the jumper bar must be removed.
- TH1 and TH2 were connected to each other through a jumper bar at the factory. Remove the jumper bar and connect these terminals to the separate regenerative discharge unit and resistor thermal switch.
- Only the α SVU1-130 (ZA06B-6089-H106) has FAN1 and FAN2 terminals. Connect the terminals to the fan motor (K11 cable) of the separate regenerative discharge unit (other than the ZA06B-6089-H106). If a fan is to be used with the α SVU1-80 the fan power should be connected to L1C and L2C through a 5-amp circuit breaker as shown.
- For CE Mark applications, an MCC that complies with European standards should be selected. The user should determine details of the use of the MCC.

7.4 Connection Details

K1—Servo Command Signal Cable (α 6/3000, α 12/3000, α 22/2000, α 30/3000, α 40/2000)

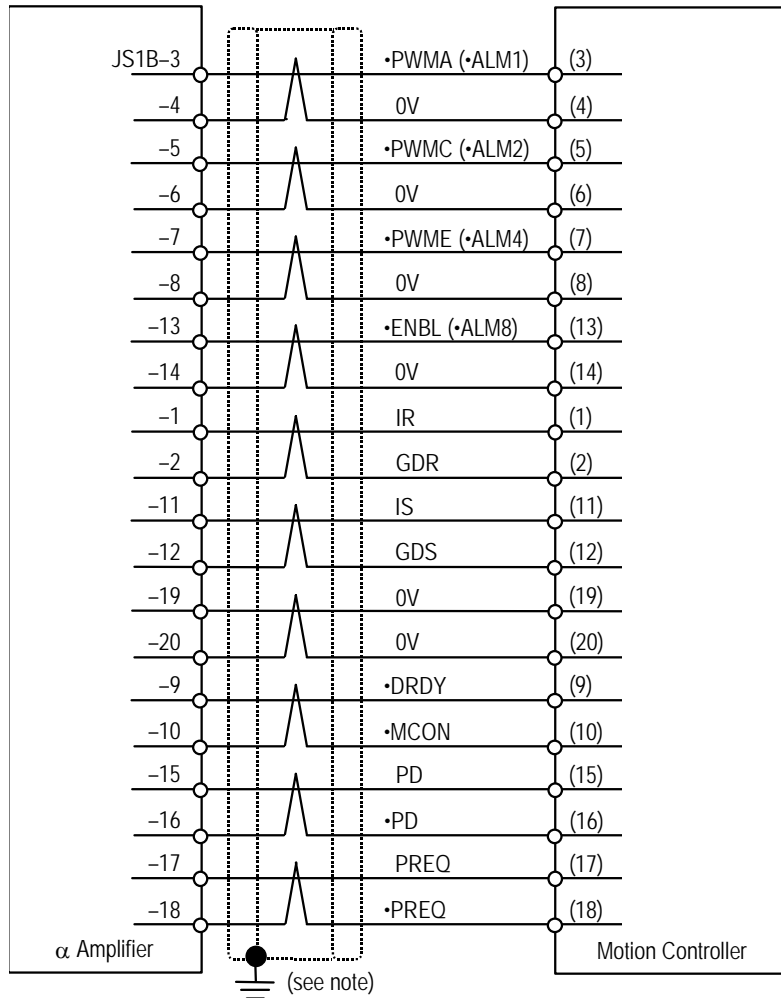

NOTES

The servo command cables for the DSM300 Series controller (IC800CBL001 and IC800CBL002) must be purchased from GE Intelligent Platforms. Proper tooling is required to assemble the connectors. For custom length cables, contact your GE Intelligent Platforms Distributor or Sales Engineer.

Grounding the cable shield using the grounding bar (Z44B295864-001) and cable grounding clamp (ZA99L-0035-0001) will provide greater noise immunity.

- Wire: 0.08mm² twisted pair group shielded cable (10 pairs). The following wire is recommended for the K1 cable: 28 AWG x 10 pairs (20 conductors).

Servo Products Specification Guide

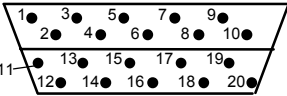
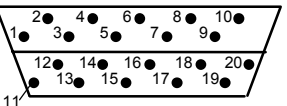
Cable (K1)	GE Intelligent Platforms Part No.	Connector Manufacturer
DSM300 controller to Servo Amplifier (JS1B)	IC800CBL001 (1 meter) IC800CBL002 (3 meter)	Cable must be purchased from GE Intelligent Platforms (connectors not sold separately)*
GE Intelligent Platforms controller other than DSM302 to Servo Amplifier (JS1B)	IC800CBL003 (2 meter)	<p>Hirose Electric Co., Ltd.</p>  <p>Honda Tsushin Kogyo Co., Ltd. (PCR-E20FA)</p>  <p><i>Connectors viewed from back (solder/crimp side).</i></p>

***NOTE:** DSM302 cables cannot be customer-manufactured and uses a 36-pin connector on its end. The DSM302 module requires IC693ACC355 Axis Terminal Board and either IC693CBL324 (1 meter) or IC693CBL325 (3 meter) Terminal Board Cable to access axis I/O such as Home Switch Input, Over Travel Inputs, or Strobe (registration) Inputs.

Servo Products Specification Guide

K2—Motor Encoder Feedback Cable ($\alpha 6/3000$, $\alpha 12/3000$, $\alpha 22/2000$, $\alpha 30/3000$, $\alpha 40/2000$)

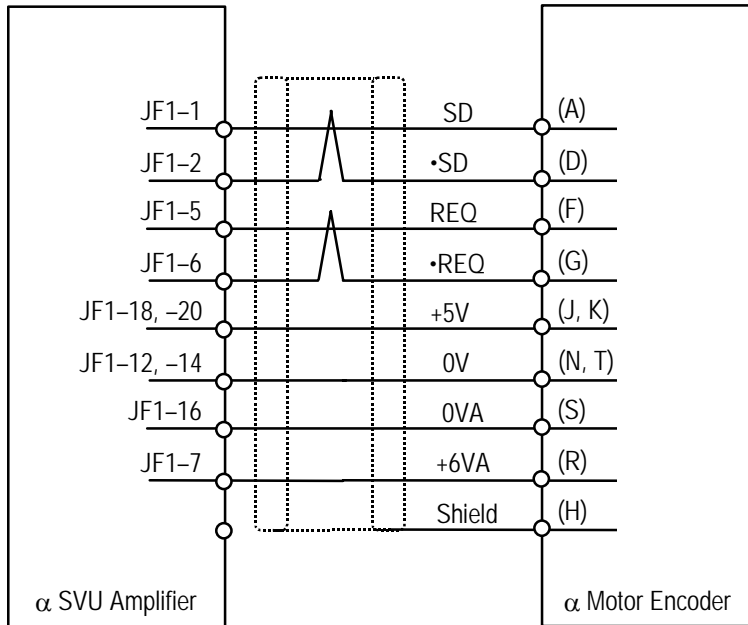

- Prefinished 14m Cable, Part number: CF3A-2MPB-0140-AZ (severe duty)
- Wire: for +5V, 0V use two parallel conductors of 0.5mm² (20 AWG) or larger when the wire length does not exceed 14m. When the wire length exceeds 14m, wire gauge must be increased to ensure that the sum of the electrical resistance of 0V and 5V circuit does not exceed 0.5 ohms. For 6VA, 0VA use 0.5mm² (20 AWG) or larger; for SD, *SD, REQ, *REQ use 0.18mm² (24 AWG) or larger twisted pair with 60% braid shield.

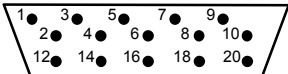
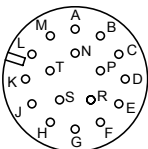
Connector	GE Intelligent Platforms Part No.	Manufacturer
Servo Amplifier (JF1)	ZA06B-6073-K214	Hirose Electric Co., Ltd. (F140-2015S) [connector cover: FI-20-CV]  Connector viewed from back (solder/crimp side).
Servo Motor Encoder	Z44A730464-G38 (CE EXT GND pin type) Alpha 6 ZA06B-6050-K115	Hirose Electric Co., Ltd. (MS3106A 20-29SW, straight) (MS3108B 20-29SW, elbow) 

K3—Three-Phase Servo Power Cable

For a power supply voltage of 200–240 VAC 50/60 Hz

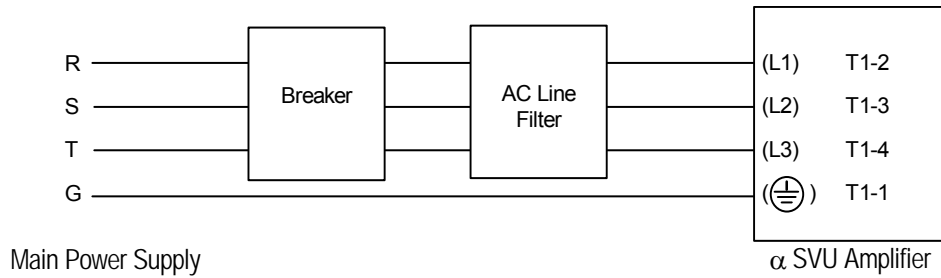

- For αSVU1-80, use 600 V, 4-conductors (JIS C 3312) of 3.5mm² (12 AWG) or larger, heat-resistive vinyl cable (nonflammable polyflex cable with a max. conductor temperature of 105° C) of 3.5mm² (12 AWG) or more.
- For αSVU1-130, use 600 V, 4-conductors (JIS C 3312) of 5.5mm² (10 AWG) or larger.
- Use M4 terminal board screws on α SVU amplifier

K4—Motor Power Cable (α6/3000)

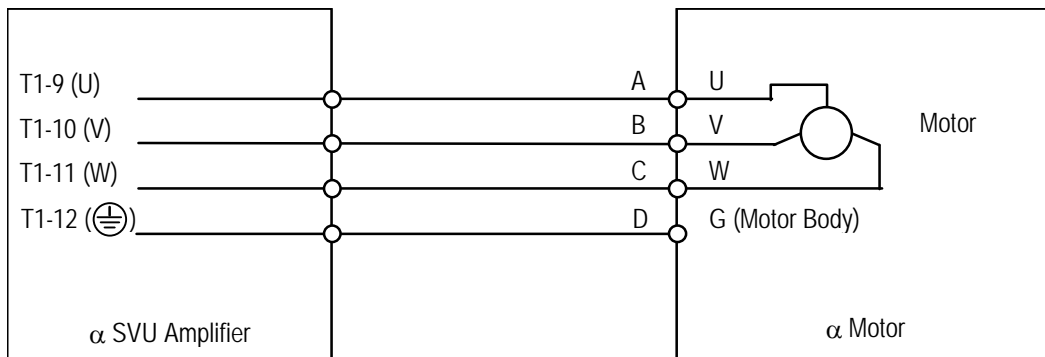

- Prefinished 14m Cable, Part number: IC800CBL061 (severe duty)
- Wire: 4-conductor, 12 AWG, Type S0 power cord, PUR (polyurethane) jacket

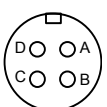
Connector	Part No.	Maker
Servo Amplifier T1 Terminal Board	N/A (M4 Spring Spade)	N/A
Servo Motor	Z44A730464-G20 (CE EXT GND pin)	DDK CE Series (CE02-6A22-22DS) 

Servo Products Specification Guide

K4—Motor Power Cable (α 12/3000, α 22/2000)

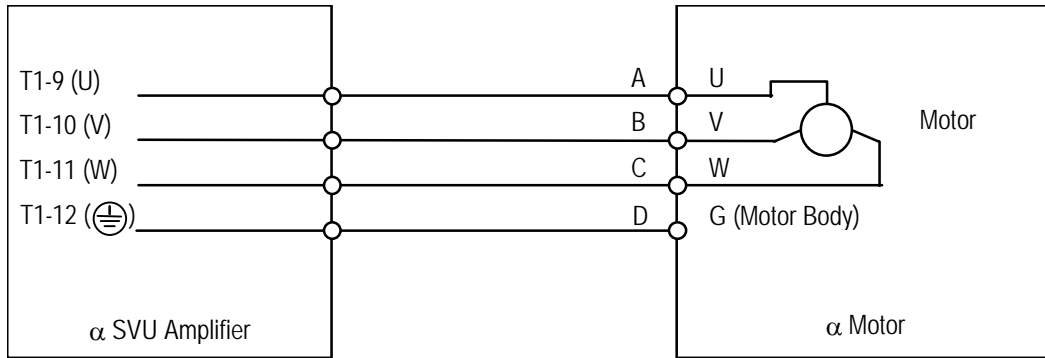

- Prefinished 14m Cable, Part number: IC800CBL061 (severe duty)
- Wire: 4-conductor, 12 AWG, Type S0 power cord, PUR (polyurethane) jacket

Connector	Part No.	Maker
Servo Amplifier T1 Terminal Board	N/A (M4 Spring Spade)	N/A
Servo Motor	Z44A730464-G20 (CE EXT GND pin)	DDK CE Series (CE02-6A22-22DS) <div style="text-align: center;"> </div>

Servo Products Specification Guide

K4—Motor Power Cable (α30/3000, α40/2000)

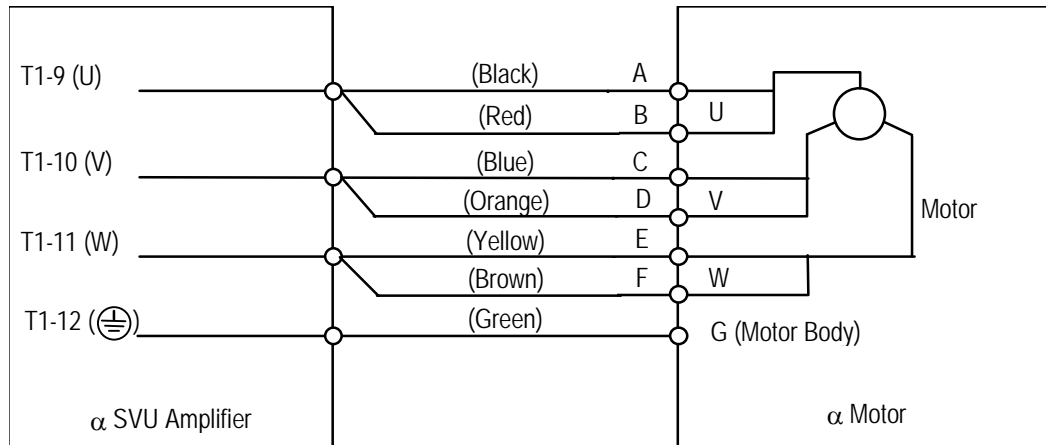

- Prefinished 14m Cable, Part number: CP5A-1MPB-0140-AZB (severe duty)
- Wire: 7-conductor, 12 AWG, Type SO power cord, PUR (polyurethane) jacket

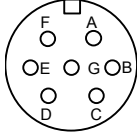
Connector	Part No.	Maker
Servo Amplifier T1 Terminal Board	N/A (M4 Spring Spade)	N/A
Servo Motor	Z44A730464-G21 (CE EXT GND pin)	DDK CE Series (CE02-6A24-10GS) 

K5—Amplifier Emergency Stop Connection

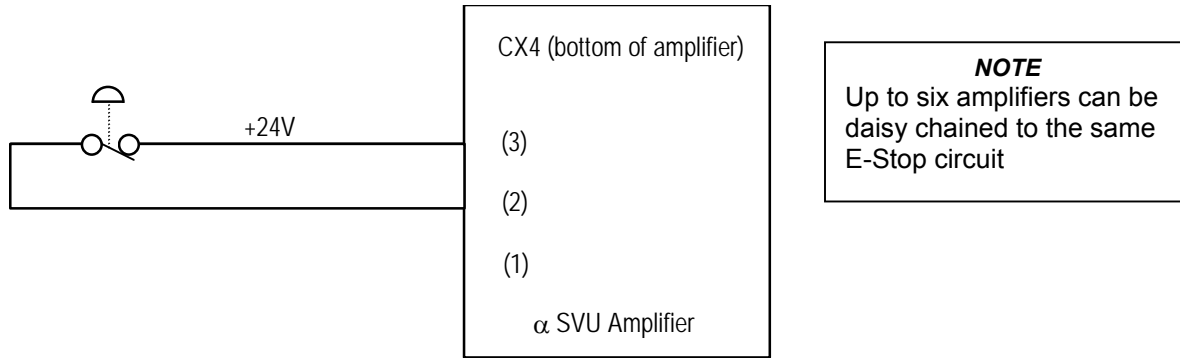

- Wire: 2-conductor 0.75mm² (20 AWG)

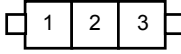
Connector	GE Intelligent Platforms Part No.	Manufacturer
Servo Amplifier CX4	ZA02B-0120-K321 (included with amplifier packages)	AMP Housing: 1-178128-3; Contact: 1-175218-2 (crimp terminal)  Connector viewed from wire insertion side.

K6—Amplifier Control Power Connection

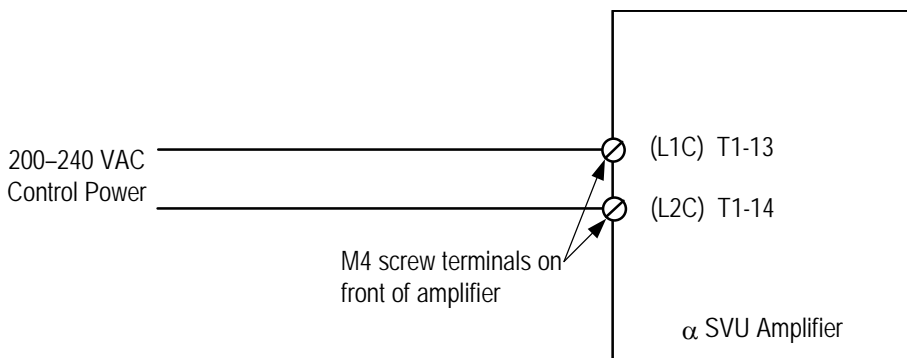

- Wire: 300V, 2-conductor 1.25mm² (16 AWG) or larger

K7—Separate Regenerative Discharge Unit Power Cable
 (α6/3000, α12/3000, α22/2000, α30/3000, α40/2000)

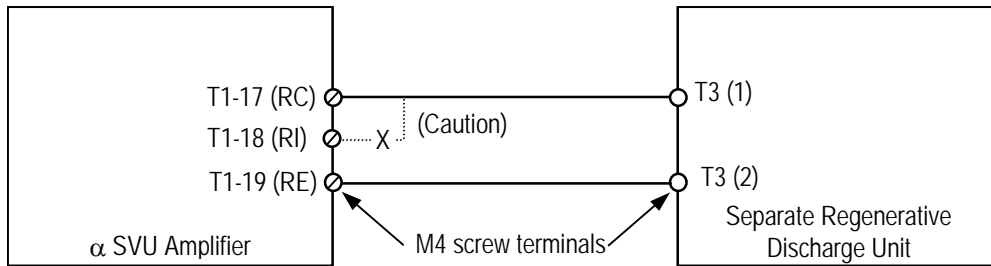

CAUTION

When a separate regenerative discharge unit is connected, remove the factory-installed shorting bar between terminals T1-17 (RC) and T1-18 (RI).

- Wire: 600 V, 2-conductor, 2.0mm² (14 AWG) or larger

K8—Separate Regenerative Discharge Unit Thermal Protection Cable
 (α6/3000, α12/3000, α22/2000, α30/3000, α40/2000)

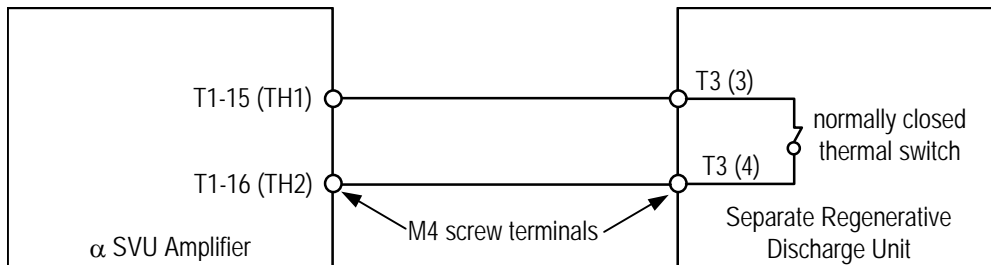

CAUTION

When a separate regenerative discharge unit is connected, the DIP switches on the front of the amplifier must be set for the proper unit. See Section 5.7 for more information.

- Wire: 600 V, 2-conductor, 0.75mm² (18 AWG) or larger

Servo Products Specification Guide

K9—Optional Absolute Encoder Battery Cable ($\alpha 6/3000$, $\alpha 12/3000$, $\alpha 22/2000$, $\alpha 30/3000$, $\alpha 40/2000$)

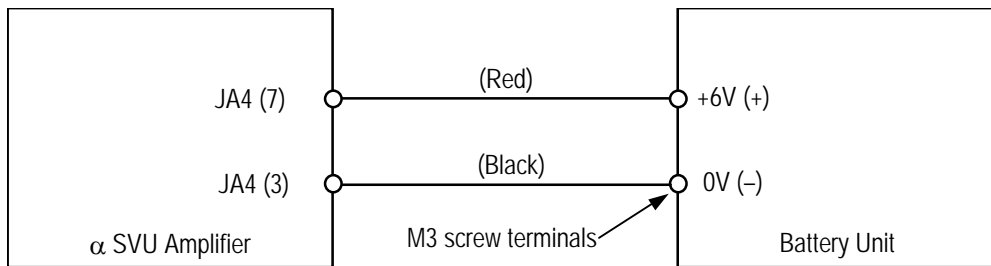

- Prefinished 2m Cable: 44C741863-001 (supplied as a part of α SVU Series Battery Backup Kit IC800ABK001)
- Wire: 2-conductor, 0.75mm² (20 AWG)

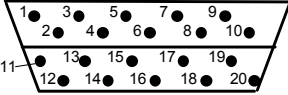
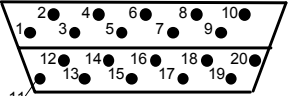
Cable	GE Intelligent Platforms Part No.	Connector Manufacturer
Servo Amplifier JA4	ZA02B-0120-K301	<p>Hirose Electric Co., Ltd.</p>  <p>Honda Tsushin Kogyo Co., Ltd. (PCR-E20FA)</p>  <p>Connectors viewed from back (solder/crimp side).</p>

K10—Emergency Stop/Power Enable Cable
 (α6/3000, α12/3000, α22/2000, α30/3000, α40/2000)

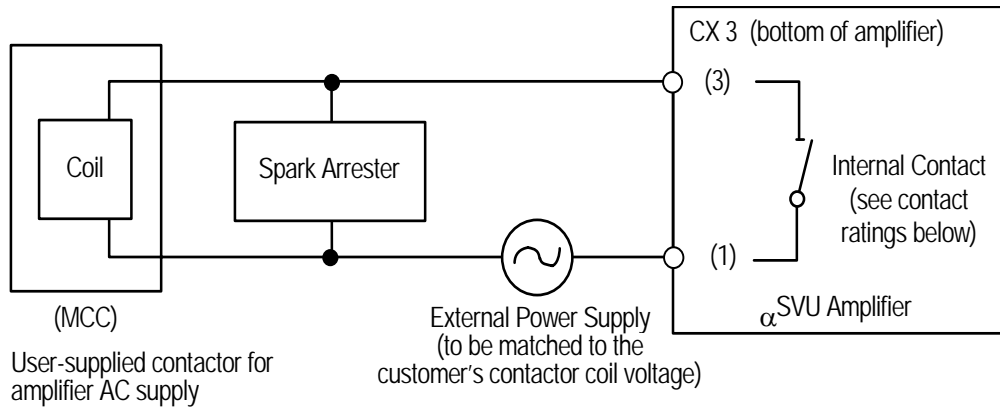

- Wire: 2-conductor, 1.25mm² (16 AWG) or larger

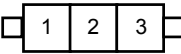
Connector	GE Intelligent Platforms Part No.	Manufacturer
Servo Amplifier CX3	ZA06B-6089-K201 (included with α Series amplifier packages IC800APK080 and IC800 APK130)	AMP Housing: 1-178128-3; Contact: 1-175218-2 (crimp terminal)  Connector viewed from wire insertion end

Contacter Ratings:

Specification of internal contact	Resistor load (cosφ=1)	Inductance load (cosφ=0.4, L/R=7msec)
Rated load	250 VAC, 5A 30VDC, 5A	250 VAC, 2A 30 VDC, 2A
Max. current	5A	5A

K11—Separate Regenerative Discharge Unit Fan Supply Cable (ZA06B-6089-H711 or ZA06B-6089-H713)

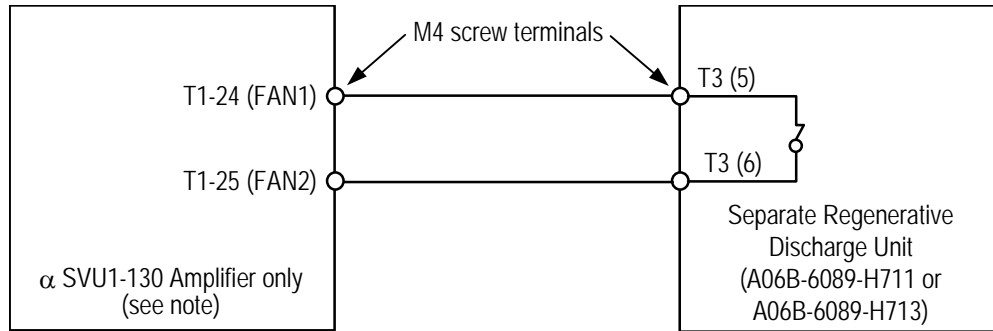

NOTE

Only the α SVU1-130 amplifier has separate fan power supply terminals. When using the ZA06B-6089-H713 unit with the α SVU1-80 amplifier, connect the fan power to terminals T1-13 (L1C) and T1-14 (L2C) through a 5A circuit breaker.

- Wire: 300 V, 2-conductor, 2.0mm² (16 AWG) or larger

K12—Motor Brake Power Connection

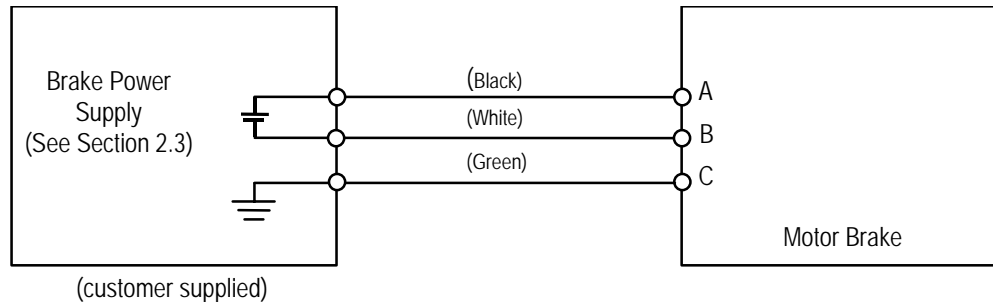

- Prefinished 14m Cable, Part number: Z44C742238-004 (severe duty)
- Wire: 330 V, 3-conductor, 20 AWG, 80 °C, PUR (polyurethane) jacket

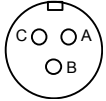
Connector	GE Intelligent Platforms Part No.	Manufacturer
Servo Motor Brake	Z44A730464-G26	AMP 3102A-10SL-3P  Connector viewed from solder side

K13—Cooling Fan Power Connection (α 40/2000)

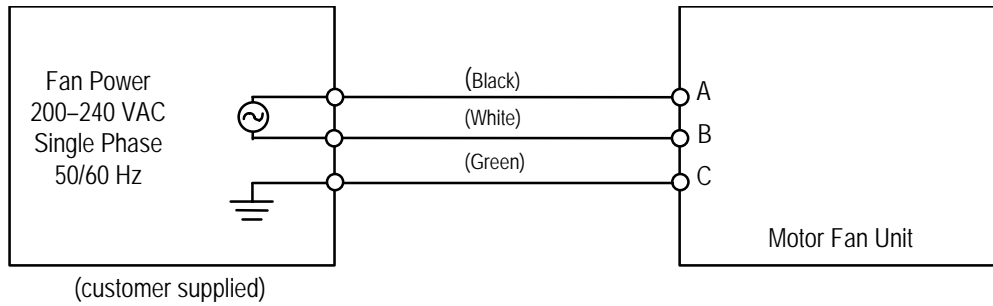

- Prefinished 14m Cable, Part number: Z44C742238-004 (severe duty)
- Wire: 330 V, 3-conductor, 20 AWG, 80 °C, PUR (polyurethane) jacket

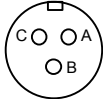
Connector	GE Intelligent Platforms Part No.	Manufacturer
Servo Motor Fan	Z44A730464-G26	AMP 3102A-10SL-3P  Connector viewed from solder side

Fan Voltage/Current Specifications:

Input voltage	Steady-state current	Surge current
200V	Approx. 0.85Arms	Approx. 1.60Arms
230V	Approx. 0.98Arms	Approx. 1.84Arms

Section 8: α SVU Series Protection and Alarm Functions

The Servo Amplifier Unit can detect error conditions and provide alarm information.

The LEDs on the front of the amplifier provide a visual cue to the status of the system by indicating, for example, when the motor and amplifier are ready to function. A built-in, seven-segment LED display indicates when an alarm condition is detected. When an alarm is detected, power is dropped and the motor is stopped by dynamic braking action. Alarm information is displayed as diagnostic data in the GE Intelligent Platforms controller. Table 95HI-23 details the alarm conditions the α SVU Series Servo Amplifier System can detect. Table 96HI-24 shows the LED indication for normal operating mode.

Table I-23. α SVU1 Series servo amplifier alarm system

<i>Alarm Type</i>	<i>LED Ind.</i>	<i>Description</i>
Over-voltage alarm (HV)	1	Occurs if the DC voltage of the main circuit power supply is abnormally high.
Low control power voltage alarm (LV)	2	Occurs if the control power voltage is abnormally low.
Low DC link voltage alarm (LVDC)	3	Occurs if the DC voltage of the main circuit power supply is abnormally low or if the circuit breaker trips.
Regenerative discharge control circuit failure alarm (DCSW)	4	Occurs if the short-time peak regenerative discharge energy is too high or if the regenerative discharge circuit is abnormal.
Over-regenerative discharge alarm (DCOH)	5	Occurs if the average regenerative discharge energy is too high (too frequent acceleration/deceleration) or the regeneration resistor overheats.
Dynamic brake circuit failure (DBRLY)	7	Occurs if the relay contacts of the dynamic brake fuse together.
Over-current alarm	8	Occurs if an abnormally high current flows through the motor.
IPM alarm	8 _a	The Intelligent Power Module (IPM) has detected an alarm due to over-current, overheating, or a drop in IPM control power voltage.
Circuit breaker	(trips)	The circuit breaker trips if an abnormally high current (exceeding the working current of the circuit breaker) flows through it.

Table I-24. α SVU1 Series servo amplifier alarm system

<i>Type</i>	<i>LED Ind.</i>	<i>Description</i>
Amplifier not ready	—	The servo amplifier is not ready to drive the motor.
Amplifier ready	0	The servo amplifier is ready to drive the motor.

Part II:
 β Servo
System

Section 9: β Servo System Block Diagram

The following block diagram shows the interconnections of a typical β Series servo system:

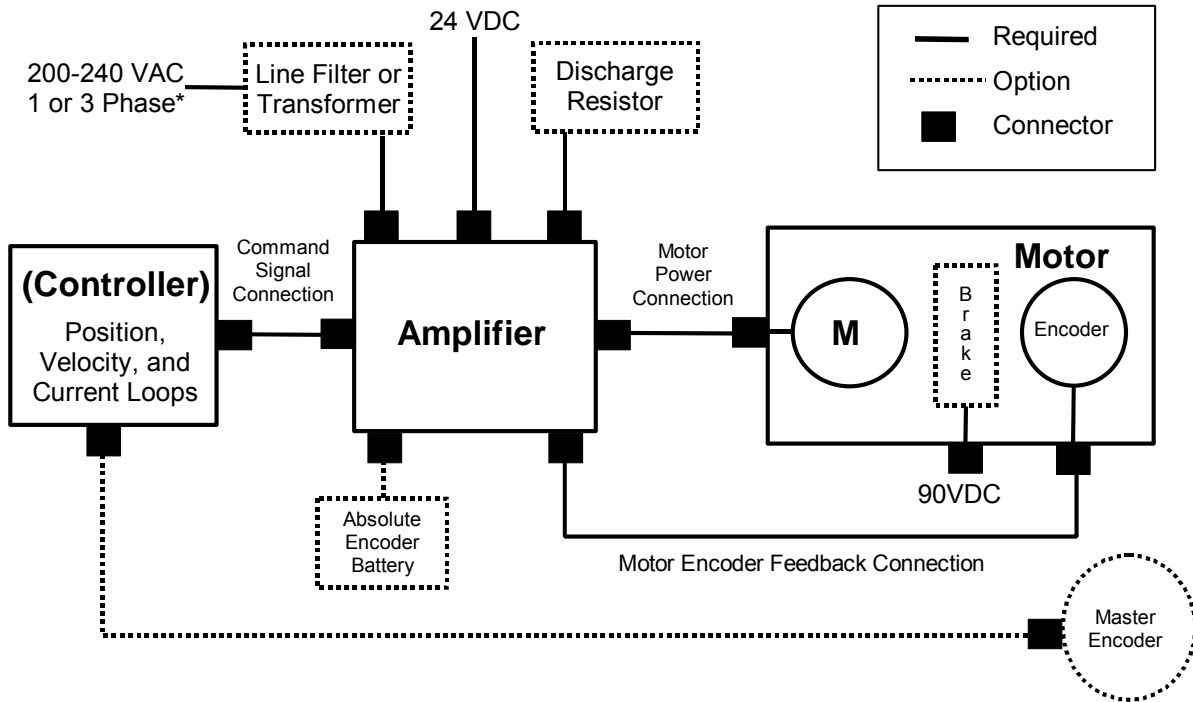

Figure II-1. β Series servo block diagram

NOTE

A 24 VDC power supply, circuit breaker, electromagnetic contactor, surge suppresser, and transformer or line filter should be user-installed as part of the system. See β Servo System Package Options in Section 12: and β Servo Installation in Section 13: of this document for more information.

- For single phase input, the lifetime of the amplifier is reduced because of higher input current. For operation of $\beta 6/2000$ or $\alpha C12/2000$ motors at acceleration/deceleration duty cycles greater than 1 cycle/20 seconds, 3-phase input is recommended. The output power of these motors when operated in ambient temperatures greater than 40°C must be derated linearly at 1%/°C above 40°C up to a maximum ambient temperature of 55°C.

Section 10: β Series Servo Product Overview

10.1 β Series Motors

The β Series servo motors are all digital systems with built-in 32K serial encoders. All β Series motors are available with an optional holding brake. The servo motors must be used with the designated amplifier package and a GE Intelligent Platforms motion controller such as the Motion Mate* DSM 300.

Table II-1 provides a summary of the β Series servo motors. See Section 11: for more detailed motor specifications.

Table II-1. β Series Servo Motors

Motor	Rated Torque	Power Rating	Required Amplifier Kit	Motor Catalog #
β 0.5/3000	0.5 Nm (5.6 in-lbs) continuous stall torque; 3000 RPM	0.2 kW	12 Amp (IC800BPK012)	Motor Only: ZA06B-0113-B075#7008 Motor w/ Brake: ZA06B-0113-B175#7008
β 2/3000	2 Nm (17 in-lbs) continuous stall torque; 3000 RPM	0.5 kW	12 Amp (IC800BPK012)	Motor Only: ZA06B-0032-B075#7008 Motor w/ Brake: ZA06B-0032-B175#7008
β 3/3000	3 Nm (26.6 in-lbs) continuous stall torque; 3000 RPM	0.5 kW	20 Amp (IC800BPK020)	Motor Only: ZA06B-033-B075#7008 Motor w/ Brake: ZA06B-033-B175#7008
β 6/2000	6 Nm (53 in-lbs) continuous stall torque; 2000 RPM	0.9 kW	20 Amp (IC800BPK020)	Motor Only: ZA06B-0034-B075#7008 Motor w/ Brake: ZA06B-0034-B175#7008
α C12/2000	12 Nm (106 in-lbs) continuous stall torque; 2000 RPM	1.0 kW	20 Amp (IC800BPK020)	Motor Only: ZA06B-0141-B075#7008 Motor w/ Brake: ZA06B-0141-B175#7008
β M0.5/4000	0.65 Nm (5.8 in-lbs) continuous stall torque; 4000 RPM	0.2 kW	200 Amp (IC800PBK020)	Motor Only: ZA06B-0115-B075#0008 Motor w/ Brake: ZA06B-0115-B175#0008
β M1/4000	1.2 Nm (10.6 in-lbs) continuous stall torque; 4000 RPM	0.4 kW	200 Amp (IC800PBK020)	Motor Only: ZA06B-0116-B075#7008 Motor w/ Brake: ZA06B-0116-B175#7008

10.2 β Series Motor Speed–Torque Curves

The curves shown below illustrate the relationship between the speed of the motor and the output torque. The motor can operate continuously at any combination of speed and torque within the prescribed continuous operating zone. The limit of the continuous operating zone is determined with the motor's ambient temperature at 40°C and its drive current as pure sine wave. The current of the servo drive unit limits actual operation.

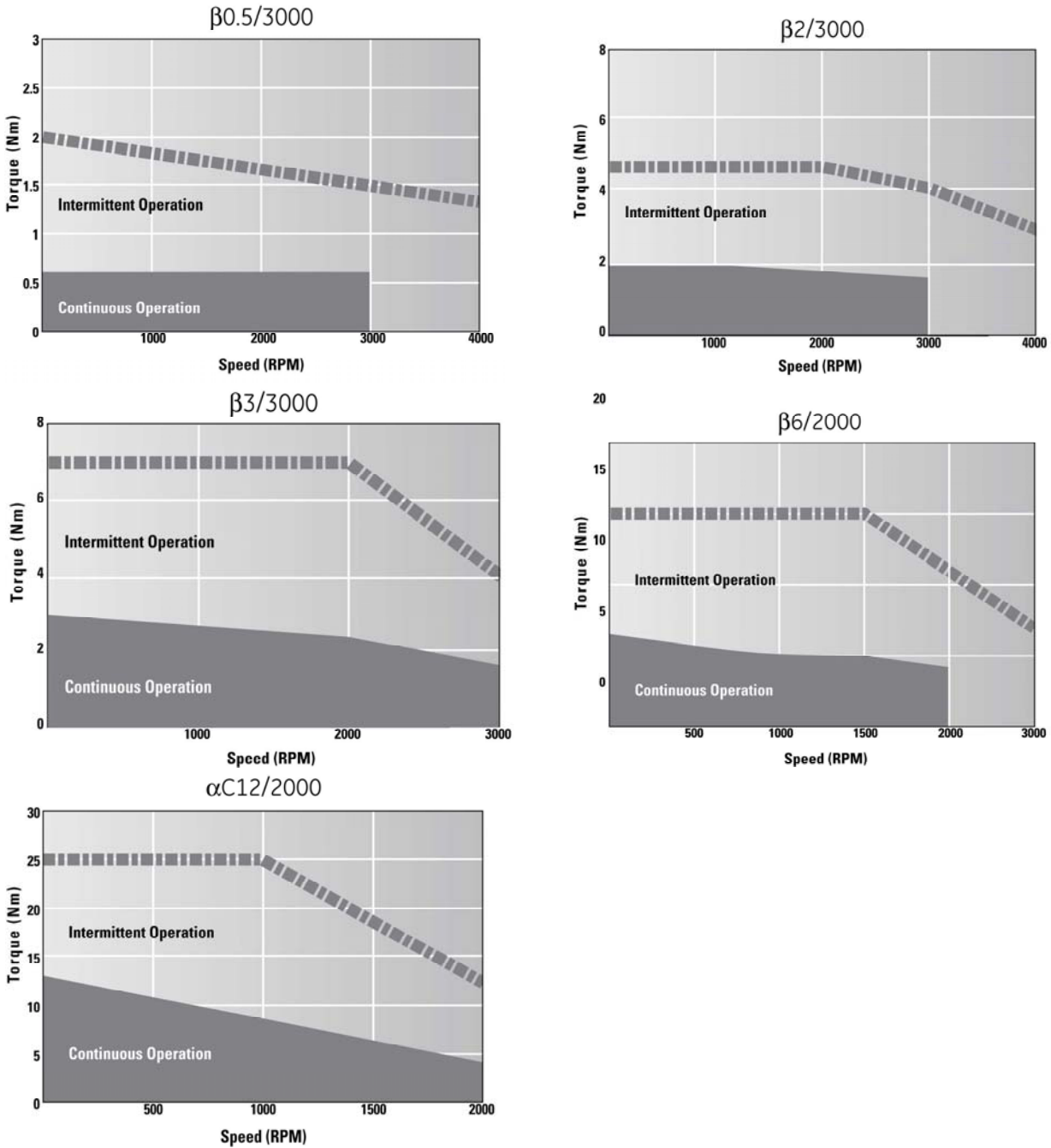

Figure II-2. β Series motor speed-torque curves

Servo Products Specification Guide

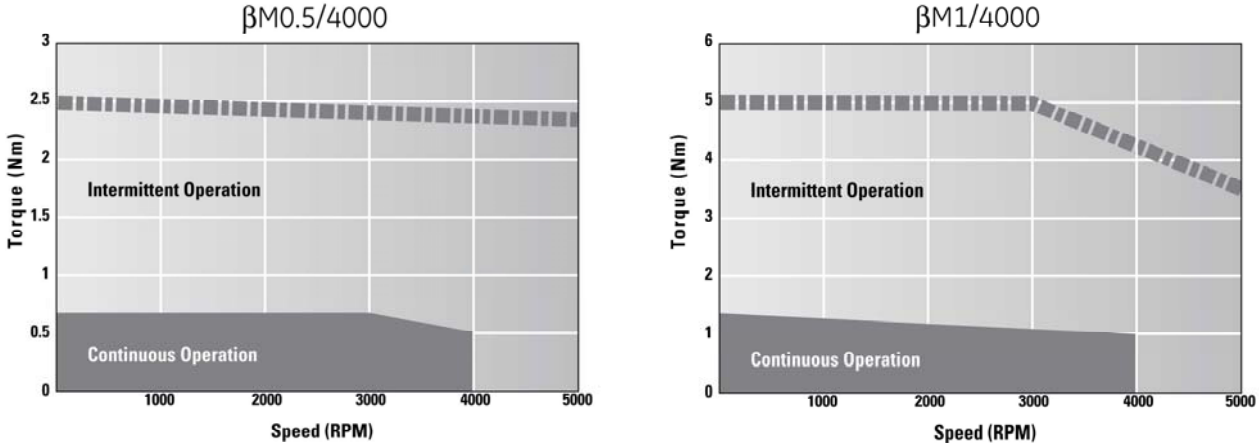

Figure II-3. βM Series motor speed-torque curves

10.3 β Series Motor Holding Brake

Any of the servo motors can be ordered with a holding brake. The brake is used to prevent movement on horizontal axes or falling along the vertical axis when the servo motor control is turned off.

Brakes are spring-set and electrically released and are designed for holding stationary loads only. Using the holding brake to stop a moving axis may damage the motor or severely reduce its service life.

The specifications of the built-in brakes are listed in Table II-2.

Table II-2. β Series Servo Motors - Brake Specifications

Parameter	SERVO PACKAGE				
	$\beta 0.5/3000$	$\beta 2/3000$	$\beta 3/3000$	$\beta 6/2000$	$\alpha C12/2000$
Brake torque	5.75 in-lb 0.65 Nm 6.6 kgf-cm	17.7 in-lb 2 Nm 20 kgf-cm	71 in-lb 8 Nm 82 kgf-cm	71 in-lb 8 Nm 82 kgf-cm	310 in-lb 35 Nm 357 kgf-cm
Release Response Time	40 msec	60 msec	80 msec	80 msec	150 msec
Brake Response Time	20 msec	10 msec	40 msec	40 msec	20 msec
Supply Voltage and Current	90 VDC ($\pm 10\%$) 0.1 A or less	90 VDC ($\pm 10\%$) 0.3 A or less	90 VDC ($\pm 10\%$) 0.4 A or less	90 VDC ($\pm 10\%$) 0.4 A or less	90 VDC ($\pm 10\%$) 0.6 A or less
Weight Increase	Approx. 0.88 lb Approx. 0.4 kg	Approx. 3.3 lb Approx. 1.5 kg	Approx. 5.1 lb Approx. 2.3 kg	Approx. 5.1 lb Approx. 2.3 kg	Approx. 13.9 lb Approx. 6.3 kg
Inertia Increase	0.00008 in-lb-s ² 0.00009 kg m ² 0.0009 kgf-cm-s ²	0.00017 in-lb-s ² 0.00002 kg m ² 0.0002 kgf-cm-s ²	0.00061 in-lb-s ² 0.00007 kg m ² 0.0007 kgf-cm-s ²	0.00061 in-lb-s ² 0.00007 kg m ² 0.0007 kgf-cm-s ²	0.0052 in-lb-s ² 0.0006 kg m ² 0.006 kgf-cm-s ²

Table II-3. βM Series Servo Motors - Brake Specifications

Parameter	SERVO PACKAGE	
	$\beta M0.5/4000$	$\beta M1/4000$
Brake torque	5.75 in-lb 0.65 Nm 6.6 kgf-cm	10.6 in-lb 1.2 Nm 12.17 kgf-cm
Release Response Time	40 msec	40 msec
Brake Response Time	20 msec	20 msec
Supply Voltage and Current	24 VDC ($\pm 10\%$) 0.5 A or less	24 VDC ($\pm 10\%$) 0.5 A or less
Weight Increase	Approx. 2.2 lb Approx. 1 kg	Approx. 3.3 lb Approx. 1.5 kg
Inertia Increase	0.00016 in-lb-s ² 0.000018 kg m ² 0.0018 kgf-cm-s ²	0.00030 in-lb-s ² 0.000034 kg m ² 0.00034 kgf-cm-s ²

An example of a typical **user-supplied** brake power supply is shown below:

Servo Products Specification Guide

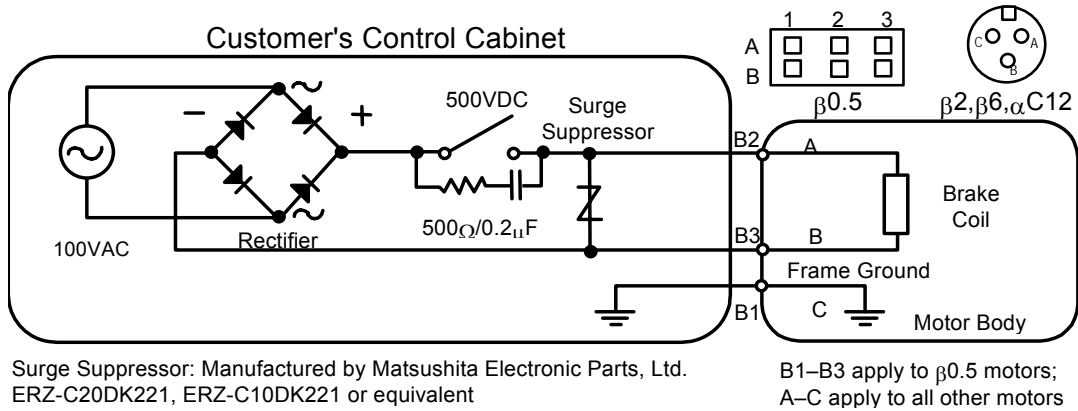

Figure II-4. Typical user-supplied brake power supply

NOTE

Use a full-wave rectified 100VAC or 90VDC as a power supply. Do not use a half-wave rectified 200 VAC, which may damage the surge suppressor. Use a rectifier with a dielectric strength of 400V or higher. Connect RC filter as shown in the above drawing to protect the contact of the switch.

10.4 β Series Servo Amplifiers

The following table shows which amplifier model is included in each β Series servo package:

Table II-4. β Series Servo Amplifier Models

Motor	Amplifier Model	Amplifier Catalog #	Amplifier Package Catalog #
β 0.5/3000	β 12	ZA06B-6093-H101	IC800BPK012
β 2/3000	β 12	ZA06B-6093-H101	IC800BPK012
β 3/3000	β 20	ZA06B-6093-H102	IC800BPK020
β 6/2000	β 20	ZA06B-6093-H102	IC800BPK020
β M0.5/4000	β 20	ZA06B-6093-H102	IC800BPK020
β M1/4000	β 20	ZA06B-6093-H102	IC800BPK020
α C12/2000	β 20	ZA06B-6093-H102	IC800BPK020

As a convenience, amplifiers can also be ordered as a package containing all of the components required to operate the amplifier in a servo system, as detailed in the following table:

Table II-5. β Series Servo Amplifier Packages

Description	Package Contents*	Catalog #
12 Amp β Series Amplifier Package	Contains 1 of each of the following: <ul style="list-style-type: none"> • SVU1-12 Amp (ZA06B-6093-H101) • Fuse (ZA06B-6073-K250) • Connector Kit (ZA06B-6093-K305) • E-Stop Connector (ZA02B-0120-K301) • 100 Watt Discharge Resistor (ZA06B-6093-H402) 	IC800BPK012
20 Amp β Series Amplifier Package	Contains 1 of each of the following: <ul style="list-style-type: none"> • SVU1-20 Amp (ZA06B-6093-H102) • Fuse (ZA06B-6073-K250) • Connector Kit (ZA06B-6093-K305) • E-Stop Connector (ZA02B-0120-K301) • 100 Watt Discharge Resistor (ZA06B-6093-H402) 	IC800BPK020

* If required, amplifier package components can be ordered separately.

Section 11: β Series Servo System Specifications

The β Series Servo system consists of a motor and its corresponding amplifier. GE Intelligent Platforms offers several servo systems, which are identified in Table II-6 below.

Table II-6. Identification of Servo Systems

Parameter (Unit)	Servo System						
	$\beta 0.5/3000$	$\beta 2/3000$	$\beta 3/3000$	$\beta 6/2000$	$\beta M0.5/4000$	$\beta M1/4000$	$\alpha C12/2000$
Motor							
Rated output power (kW)	0.2	0.5	0.5	0.9	0.2	0.4	1.0
Rated torque at stall (Nm) *	0.6	2	3	6	0.65	1.2	12
Rated torque at stall (in-lb) *	5.3	17	26.6	53	5.8	10.6	105
Rated torque at stall (kgf-cm) *	6.1	20	30.5	60	6.61	12.20	122
Rated output speed (RPM)	4000	4000	3000	3000	4000	4000	2000
Rotor inertia (kg m ²)	0.00001764	0.0006566	0.00019	0.00392	0.00001764	0.000034	0.006272
Rotor inertia (in-lb-s ²)	0.00016	0.00581	0.017	0.0347	0.00016	0.00030	0.0555
Rotor inertia (kg-cm-s ²)	0.00018	0.0067	0.0019	0.040	0.00018	0.000347	0.064
Continuous current at stall A(rms)	2.8	3.2	5.3	5.6	3.0	3.0	5.9
Torque constant (Nm/A [rms]) *	0.23	0.61	0.56	1.05	0.2	0.4	2.04
Torque constant (in-lb/A [rms]) *	2.0	5.4	4.9	9.3	1.77	3.54	18
Torque constant (kgf-cm/A [rms]) *	2.3	6.2	5.7	10.7	2.0	4.1	20.8
Back EMF constant (V/1000 RPM) *	7.9	21.4	19.4	37.0	7.7	15.4	71
Back EMF constant (Vsec/rad) *	0.08	0.20	0.18	0.35	0.08	0.14	0.68
Armature resistance (Ω) *	0.80	1.4	0.5	0.85	0.95	1.55	1.092
Mechanical time constant (s) *	0.0007	0.008	0.009	0.009	0.009	0.008	0.005
Thermal time constant (min)	10	20	40	40	10	15	60
Static friction (Nm)	0.04	0.1	0.3	0.3	0.04	0.04	0.8
Static friction (in-lb)	0.35	0.89	2.7	2.7	0.35	0.35	7
Static friction (kgf-cm)	0.4	1.0	3.1	3.1	4.1	4.1	8
Maximum allowable current (A [peak])	19	18	30	30	12.5	12.5	46
Maximum theoretical torque (Nm) **	3.4	11	7	32	2.5	5	66
Maximum theoretical torque (in-lb) **	30	97	62	283	22.1	44.3	584
Maximum theoretical torque (kgf-cm) **	35	112	0.69	321	25	50.9	670
Maximum winding temperature rise (°C)	125	125	125	125	125	125	125
Weight (kg)	1.0	3.5	5	8.5	1	1.5	18
Weight (lb)	2.2	7.2	11	18.7	2.2	3.3	39.6
Amplifier							
Model	β SVU-12	β SVU-12	β SVU-20	β SVU-20	β SVU-20	β SVU-20	β SVU-20
Rated output current (rms amps)	3.2	3.2	5.9	5.9	5.9	5.9	5.9
Current limit (Peak amps)	12	12	20	20	20	20	20
Heat loss (watts)	17.5	17.5	33.3	33.3	33.3	33.3	33.3
AC Power	200–240 VAC (3-phase), 220–240 VAC (1-phase) 50/60 Hz \pm 2 Hz						
DC Power	24 VDC \pm 10% @ 0.4 Amp per amplifier						

* These values are standard values at 20°C with a tolerance of $\pm 10\%$. The speed-torque characteristics vary, depending on the type of software, parameter setting, and input voltage of the digital servo amplifiers. (The above figures show average values.) These values may be changed without prior notice.

** Theoretical values. The actual maximum torque is restricted by the current limit values of the drive amplifier.

Section 12: β Servo System Options

Designing a servo control system requires that you understand how the electrical and mechanical aspects of your system interact. GE Intelligent Platforms application engineers are available to help you determine your servo control system requirements.

Table II-7 will help you select which servo options your system requires:

Table II-7. β Servo Package Options

Servo Option	Consider Selecting When	Catalog #	Section #
Motor Holding Brake	the system design includes an axis that must hold its position when power is removed	Refer to Table II-2	10.3
Absolute Encoder Battery Backup Kit	you would like to avoid having to re-reference the position when power is restored to the control	IC800BBK021	12.1
AC Line Filters	200—240 VAC is already available to the control cabinet and no transformer is used	5.4 kW, 3-phase: ZA81L-0001-0083#3C 10.5 kW, 3-phase: ZA81L-0001-0101#C	14.2
Prefinished Cables	the cable lengths available are appropriate for your application	Refer to the “Cable Connection” Table II-22	15.1
Discharge Resistor	see “Discharging Regenerative Power” section; The 100 Watt discharge resistor is included in all β Series Amplifier Packages	20 Watt Resistor: ZA06B-6093-H401 100 Watt Resistor: ZA06B-6093-H402	14.7

12.1 Absolute Encoder Battery Packs

All β Series servo motors feature a built-in encoder that can be used in either incremental or absolute mode. To utilize the absolute capability, an optional encoder battery pack (IC800BBK021) for the β Series amplifier must be installed. This pack allows the encoder's position information to be backed up so that the machine does not need to be re-referenced to a home position every time power is restored to the servo system.

For optimal panel space utilization, a small lithium battery pack is available that snaps onto the underside of the β amplifier. An integral pigtail cable plugs directly into the CX5 connector. One battery is required for each amplifier.

Absolute Encoder Battery Kit (IC800BBK021) contains the following:

- Battery (ZA06B-6093-K001)
- Battery Holder (ZA06B-6093-K002)

Note: Current drain (per encoder) from battery:

- 20 μ A with amplifier power ON
- 200 μ A with amplifier power OFF

Connection Method

(for use with a single amplifier)

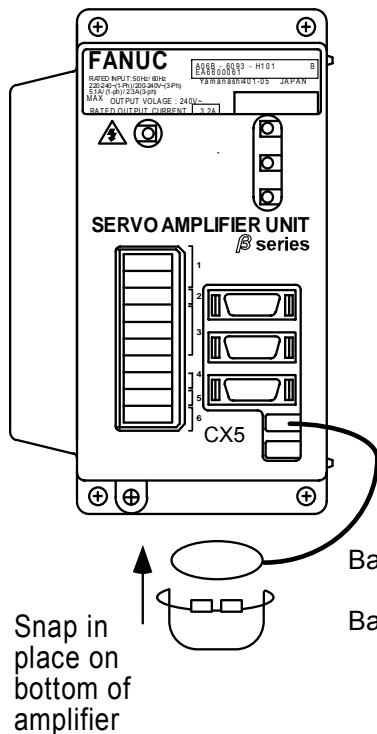

NOTE

Do not attempt to connect multiple amplifiers to one IC800BBK021 battery kit. If you wish to daisy chain multiple β Series amplifiers to one battery you must use the IC800ABK001 battery kit and the following cables:

- Z44C742433-001, battery to amplifier cable, 2m (one per battery required)
- Z44C742433-002, amplifier to amplifier cable, 250mm (one for each daisy chained amplifier required)

Figure II-5. Connecting a single β Series amplifier to an absolute encoder battery pack

Section 13: Installation Guidelines

This section includes environmental requirements, motor and amplifier dimension drawings and information on ensuring noise protection and selecting a ground fault interrupter.

13.1 Motor Environmental Requirements

The servo motor must be installed in a location that satisfies the following environmental conditions:

Table II-8. Servo amplifier environmental conditions

Condition	Description
Ambient temperature	The ambient temperature should be -10°C to 40°C. When operating the machine at a temperature higher than 40°C, it is necessary to derate the output power so that the motor's temperature rating is not exceeded.
Vibration	When installed in a machine, the vibration applied to the motor must not exceed 5G.
Altitude	No more than 1,000 m (3,300 ft) above sea level.
Drip-Proof Environment	The motors have a drip-proof structure that complies with IP65 of the IEC standard. Nevertheless, to ensure long-term performance, the motor surface should be protected from solvents, lubricants and fluid spray. A cover should be used when there is a possibility of wetting the motor surface. To prevent fluid from being led to the motor through the cable, put a drip loop in the cable when the motor is mounted. Finally, turn the motor connector sideways or downward as far as possible. If the cable connector will be subjected to moisture, it is recommended that an R class or waterproof plug be used.

For additional information, see *Servo and Spindle Motors Exposed to Liquids*, GFK-1046.

13.2 Servo Amplifier Environmental Requirements

The servo amplifier must be installed in a location that satisfies the environmental conditions listed in Table II-9.

Table II-9. Servo Amplifier Environmental Conditions

Condition	Description
Ambient temperature	0°C to 55°C (operating). -20°C to 60°C (storage and transportation).
Temperature fluctuation	Within 1.1°C/min.
Humidity	30% to 95% RH (no condensation).
Altitude	No more than 1000 m (3,300 ft) above sea level.
Vibration	No more than 0.5 G during operation.
Atmosphere	The circuitry and cooling fins must not be exposed to any corrosive and conductive vapor or liquid.

The amplifier must be installed in a cabinet that protects it from contaminants such as dust, coolant, organic solvents, acid, corrosive gas, and salt. Adequate protection must also be provided for applications where the amplifier could be exposed to radiation, such as microwave, ultraviolet, laser light, or x-rays.

Servo Products Specification Guide

To adequately protect the amplifier, you must ensure that:

- Contaminants such as dust and coolant, cannot enter through the air inlet or outlet.
- The flow of cooling air is not obstructed.
- The amplifier can be accessed for inspection.
- The amplifier can be disassembled for maintenance and later reinstalled.
- There is sufficient separation between the power and signal lines to avoid interference. Noise protection should be provided.

13.3 β servo Amplifier heat dissipation and maintenance

The amplifier contains a cooling fan that forces air through the unit. Allow for adequate clearance for airflow when installing the amplifier using the recommended distances shown in the drawings below. If possible, do not mount amplifiers one above the other unless they are staggered to prevent the heated exhaust of the lower unit from flowing over the upper unit.

β SVU-12 Maintenance Clearances

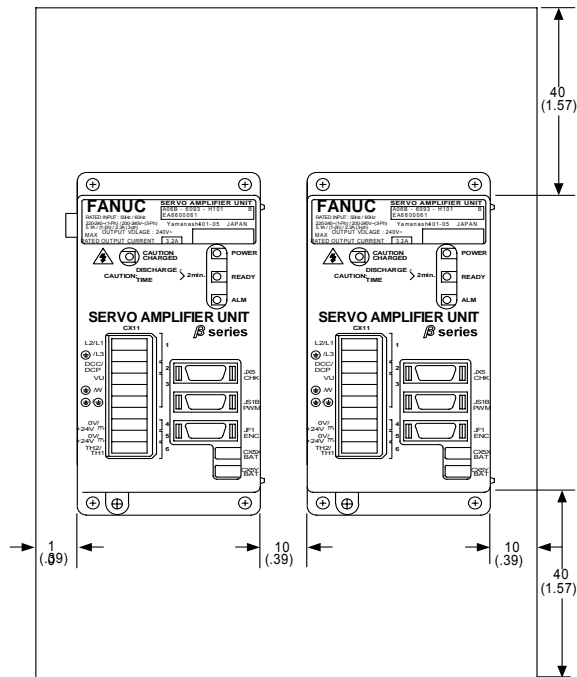

β SVU-20 Maintenance Clearances

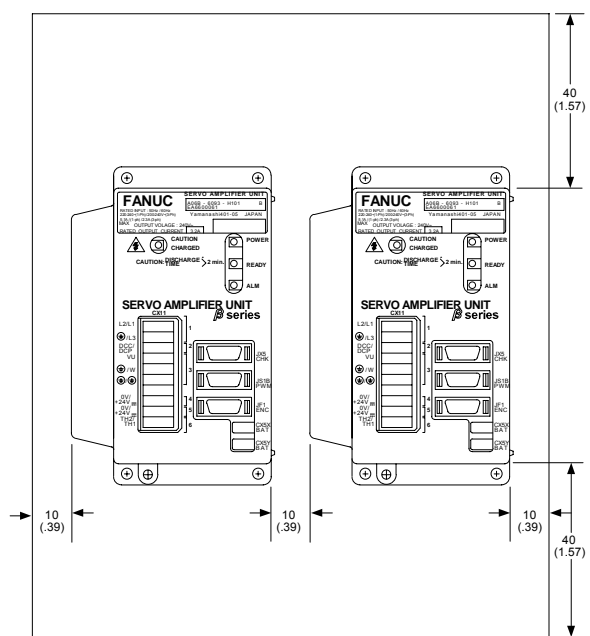

Dimensions shown in mm (in)

Figure II-6. β Series amplifier maintenance clearances

Table II-10 identifies worst-case heat dissipation values for each amplifier. These values may be used to determine heat load for sizing enclosures and cooling equipment. Heat dissipation for external regeneration resistors depends on the application and is calculated in Step 5 of “Discharging Regenerative Energy” on page II-29.

Table II-10. Heat Dissipation

Amplifier	Total Heat Dissipation	Catalog #
β SVU-12	17.5 watts	ZA06B-6093-H101
β SVU-20	33.3 watts	ZA06B-6093-H102

13.4 β and βM Series Motor Dimensions

$\beta 0.5/3000$ Motor, Front and Side Views

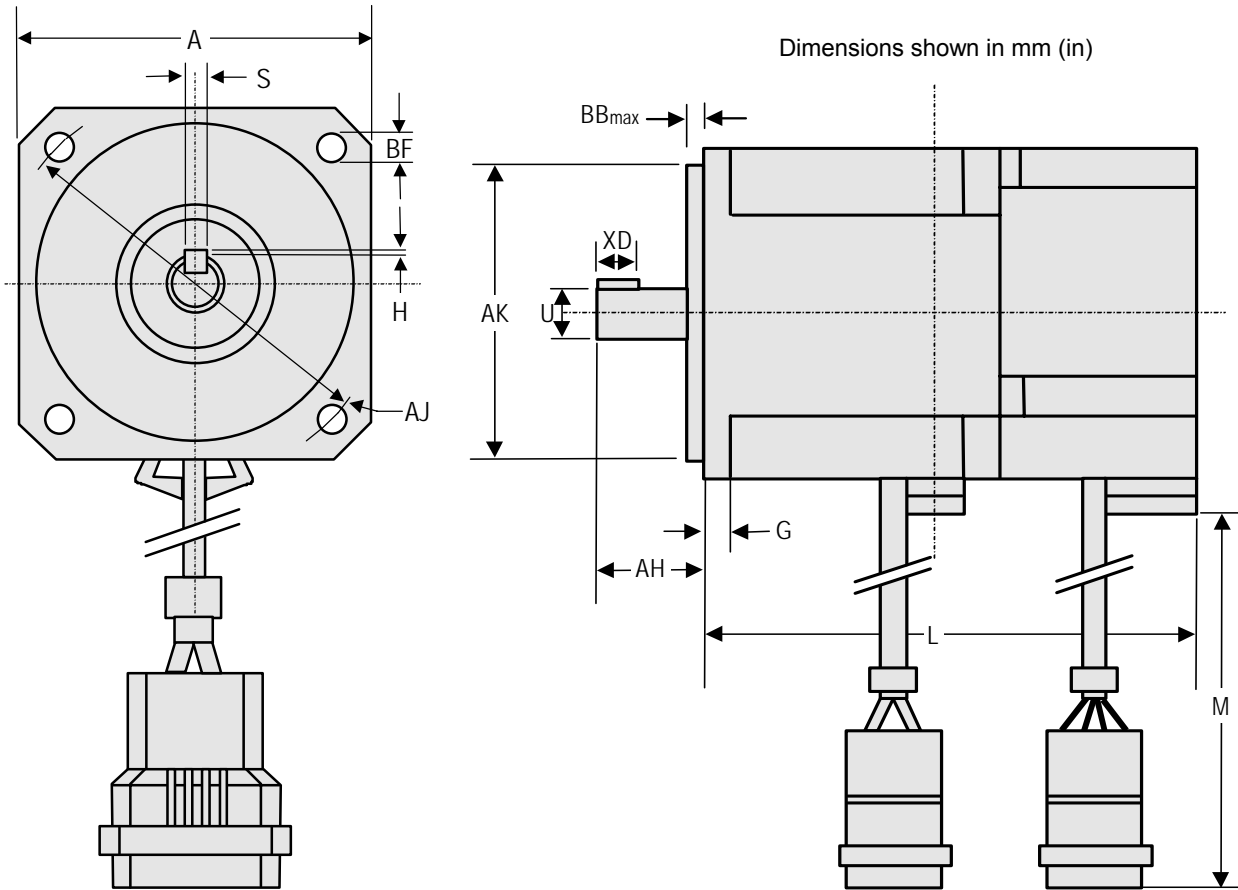

Dim.	MOTOR
	$\beta 0.5/3000$
A	60 mm (2.36 in)
S	$3^{+0}_{-0.025}$ (0.1181/0.1191)
H	$1.2^{+0}_{-0.125}$ (0.0472/0.0423)
AJ (dia.)	70 (2.76)
BF (dia.)	5.5 (.2165)

NOTES

1. Shaft diameter runout = 0.02 mm max (0.00079 in).
2. Flange surface runout = 0.06 mm max (0.00236 in).
3. Maximum radial load for output shaft is 20 kgf (44 lb).

Dim.	MOTOR	
	$\beta 0.5/3000$	$\beta 0.5/3000$ with brake
BB	3 mm (.118 in)	3 mm (.118 in)
XD	20 (.787)	20 (.787)
AK	$50^{+0}_{-0.025}$ (1.9685/1.9675)	$50^{+0}_{-0.025}$ (1.9685/1.9675)
U	$9^{+0}_{-0.009}$ (0.3543/0.3539)	$9^{+0}_{-0.009}$ (0.3543/0.3539)
G	6 (.236)	6 (.236)
AH	25 (.984)	25 (.984)
L	100 (3.94)	128 (5.04)
M	~ 300 (11.81)	~ 300 (11.81)

Figure II-7. $\beta 0.5/3000$ motor, front and side views

Servo Products Specification Guide

β 2/3000, β 3/3000, β 6/2000, and α C12/2000 Motors, Front View

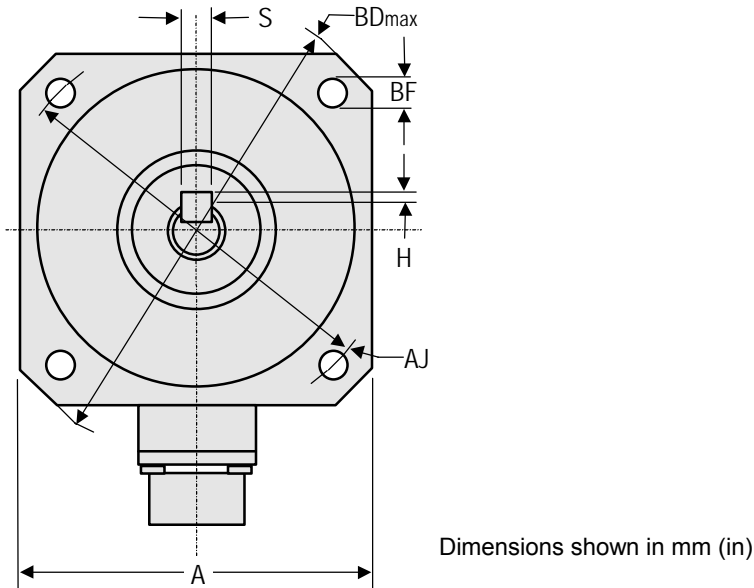

Dimension	Motor			
	β 2/3000	β 3/3000	β 6/2000	α C12/2000
A	105 mm (4.13 in)	142 mm (5.59 in)	142 mm (5.59 in)	174 mm (6.85 in)
S	5 ⁺⁰ _{-0.03} (.1969/.1957)	6 ⁺⁰ _{-0.03} (.236/.235)	6 ⁺⁰ _{-0.03} (.236/.235)	10 ⁺⁰ _{-0.036} (.394/.392)
H	2 ⁺⁰ _{-0.13} (.0787/.0736)	2.5 ⁺⁰ _{-0.13} (.0984/.0933)	2.5 ⁺⁰ _{-0.13} (.0984/.0933)	3 ⁺⁰ _{-0.29} (.118/.107)
AJ (dia.)	115 (4.53)	165 (6.50)	165 (6.50)	200 (7.87)
BF (dia.)	9 (.354)	11 (.433)	11 (.433)	13.5 (.532)
BD	134 (5.38)	190 (7.48)	190 (7.48)	240 (9.45)

NOTES FOR ALL VIEWS (see next page for side view)

1. See the β Connection section (p. 32) for more information about motor cables.
2. Shaft diameter runout = 0.02 mm max (0.00079 in) for β 2/3000, β 3/3000 and β 6/2000; 0.05 mm (0.00197 in) for α C12/2000.
3. Flange surface runout = 0.06 mm max (0.00236 in) for β 2/3000, β 3/3000 and β 6/2000; 0.10 mm (0.00394 in) for α C12/2000.
4. Maximum radial load for output shaft is 25 kgf (55 lb) for β 2/3000; 70 kgf (154 lb) for β 3/3000 and β 6/2000; 450 kgf (990 lb) for α C12/2000.

Figure II-8. β 2/3000, β 3/3000, β 6/2000, and α C12/2000 motors, front view

β 2/3000, β 3/3000, β 6/2000, and α C12/2000 Motors, Side View

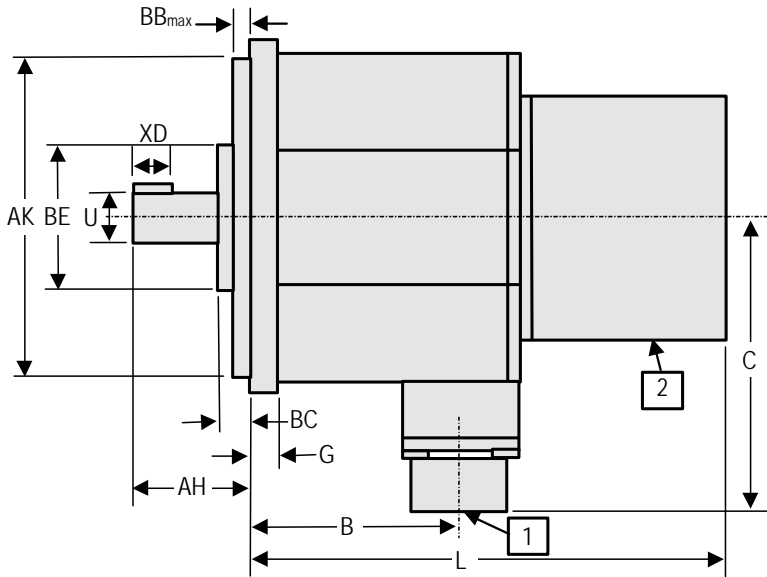

Dimensions shown in mm (in)

Dimension	Motor			
	β 2/3000	β 3/3000	β 6/2000	α C12/2000
BB	5 mm (.196 in)	5 mm (.196 in)	5 mm (.196 in)	3.2 mm (.126 in)
XD	20 (0.787)	28 (1.10)	28 (1.10)	70 (2.76)
AK	95 ⁺⁰ _{-0.035} (3.740/3.739)	130 ⁺⁰ _{-0.035} (5.118/5.117)	130 ⁺⁰ _{-0.035} (5.118/5.117)	114.3 ⁺⁰ _{-0.025} (4.50/4.499)
U	14 ⁺⁰ _{-0.011} (0.5512/0.5507)	19 ⁺⁰ _{-0.013} (0.7480/0.7475)	19 ⁺⁰ _{-0.013} (0.7480/0.7475)	35 ^{+0.01} ₋₀ (1.3783/1.3780)
BC	12 (0.472)	n/a	n/a	n/a
C	88 (3.46)	110 (4.33)	110 (4.33)	122 (4.80)
G	8 (0.315)	10 (0.394)	10 (0.394)	18 (0.709)
AH	36 (1.42)	46 (1.81)	46 (1.81)	79 (3.11)
B	93 (3.66)	79 (3.11)	117 (4.61)	166 (6.54)
L	174 (6.85)	165 (6.49)	203 (7.99)	240 (9.45)
BE	43 (1.69)	90 (3.54)	90 (3.54)	N/A

Connector	Description
1	Motor AC Power
2	Motor Encoder Feedback

Figure II-9. β 2/3000, β 3/3000, β 6/2000, and α C12/2000 motors, side view

Servo Products Specification Guide

β 2/3000, β 3/3000, β 6/2000, and α C12/2000 Motors with Brake

(Front view same as β 2/3000, β 3/3000, β 6/2000, and α C12/2000 without brake)

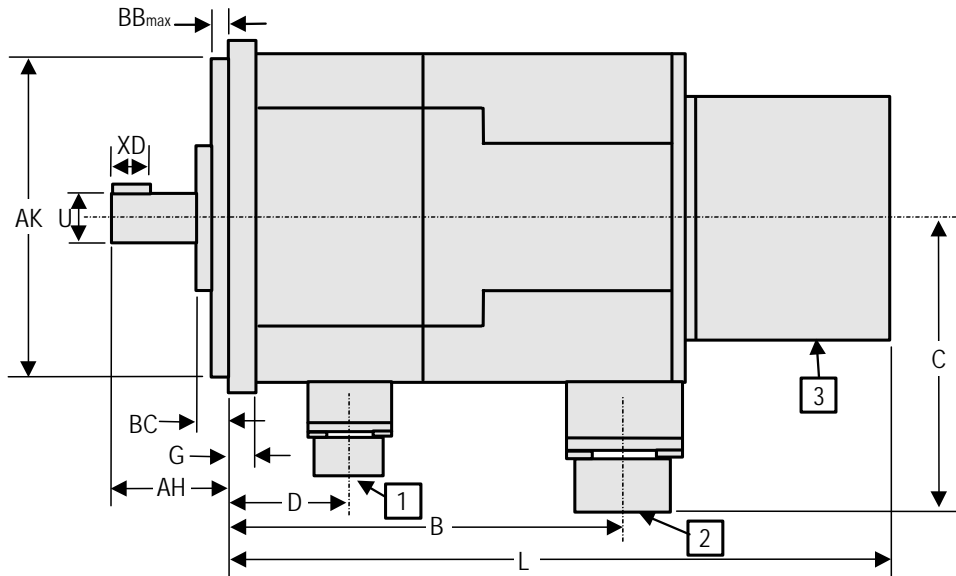

Dimension	Motor			
	β 2/3000	β 3/3000	β 6/2000	α C12/2000
BB	5 mm (0.196 in)	5 mm (0.196 in)	5 mm (0.196 in)	3.2 mm (0.126 in)
XD	20 (0.787)	28 (1.10)	28 (1.10)	70 (2.76)
AK	95 ⁺⁰ _{-0.035} (3.740/3.739)	130 ⁺⁰ _{-0.035} (5.118/5.117)	130 ⁺⁰ _{-0.035} (5.118/5.117)	114.3 ⁺⁰ _{-0.025} (4.50/4.499)
U	14 ⁺⁰ _{-0.011} (0.5512/0.5507)	19 ⁺⁰ _{-0.013} (0.74801/0.74751)	19 ⁺⁰ _{-0.013} (0.74801/0.74751)	35 ^{+0.01} ₋₀ (1.37831/1.3780)
BC	11 (0.433)	10 (0.394)	10 (0.394)	n/a
C	88 (3.46)	110 (4.33)	110 (4.33)	122 (4.80)
G	8 (0.315)	10 (0.394)	10 (0.394)	18 (0.709)
AH	36 (1.42)	46 (1.81)	46 (1.81)	79 (3.11)
D	31 (1.22)	28 (1.10)	28 (1.10)	65 (2.56)
B	149 (5.87)	131 (5.16)	169 (6.65)	238 (9.37)
L	230 (9.06)	217 (8.54)	255 (10.04)	312 (12.28)

Connector	Description
1	Brake
2	Motor AC Power
3	Motor Encoder Feedback

Figure II-10. β 2/3000, β 3/3000, β 6/2000, and α C12/2000 motors with brake, side view

Notes

- See the Connection section of the manual (p. 32) for more information about motor cables.
- Shaft diameter runout = 0.02 mm max (0.00079 in) for β 2/3000, β 3/3000 and β 6/2000; 0.05 mm (0.00197 in) for α C12/2000.
- Flange surface runout = 0.06 mm max (0.00236 in) for β 2/3000, β 3/3000 and β 6/2000; 0.10 mm (0.00394 in) for α C12/2000.
- Maximum radial load for output shaft is 25 kgf (55 lb) for β 2/3000; 70 kgf (154 lb) for β 3/3000 and β 6/2000; 450 kgf (990 lb) for α C12/2000.

βM0.5/4000, βM1/4000 Motor Front and Side Views

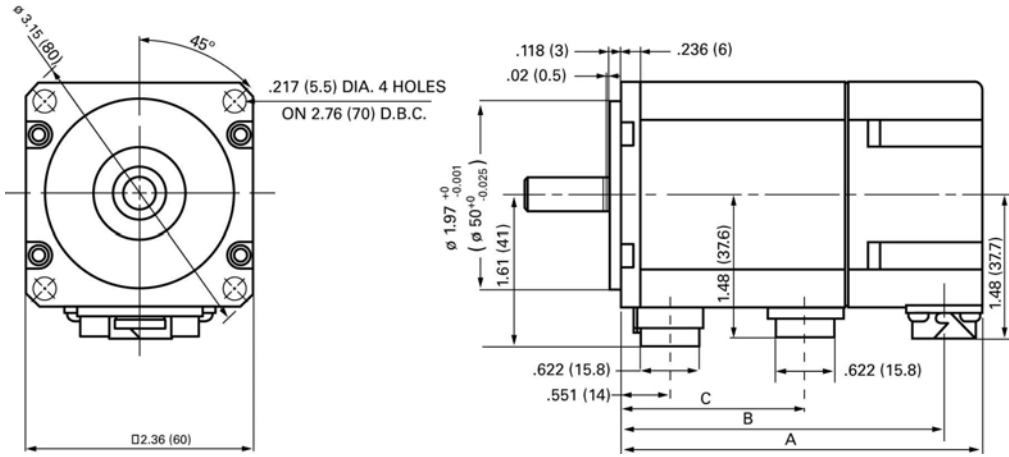

Motor

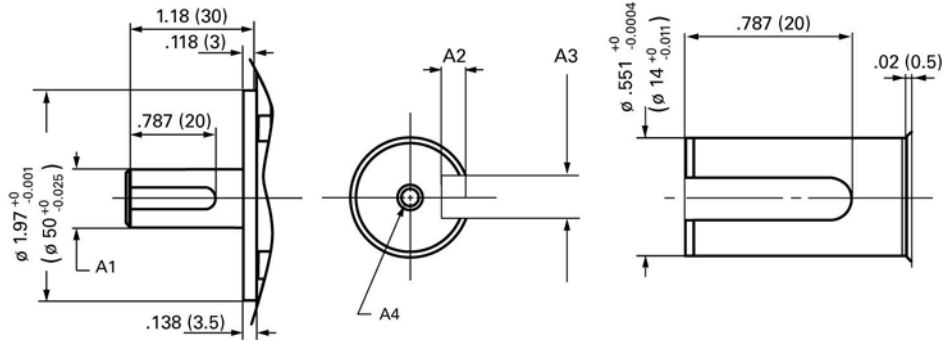

Shaft Option

Dimension	Motor	
	βM0.5/4000	βM1/4000
A	95.5 (3.76)	124.5 (4.90)
A with Brake	122 (4.80)	151 (5.94)
A1	$\Phi 9_{-0.0009}^0$ (0.3543/0.3539)	$\Phi 14_{-0.011}^0$ (0.5512/0.5507)
A2	$1.8_{0}^{+0.1}$ (0.0748/0.0709)	$3_{0}^{+0.1}$ (0.1220/0.1181)
A3	$3_{-0.029}^{-0.004}$ (0.1179/0.1169)	$5_{-0.0030}^0$ (0.1220/0.1181)
A4	M3 Depth 6	M4 Depth 10
B	85.5 (3.67)	114.5 (4.51)
B with Brake	112 (4.41)	141 (5.55)
C	49 (1.93)	78 (3.07)
C with Brake	75.5 (2.97)	104.5 (4.11)

Figure II-11. βM0.5/4000 and βM1/4000 motors with brake, side view

NOTES

1. Shaft diameter runout = 0.02 mm max for βM0.5/4000, βM1/4000.
2. Flange surface runout = 0.06 mm max for βM0.5/4000, βM1/4000.
3. Maximum radial load for output shaft is 20kgf (44lb) for βM0.5/4000, βM1/4000.

13.5 Shaft Loading

The allowable load of the motor shaft is as follows:

Table II-11. Allowable motor shaft load

<i>Motor Model</i>	<i>Radial Load</i>	<i>Axial Load</i>	<i>Front Bearing (type reference)</i>
β0.5/3000	20 kg (44 lb)	5 kg (11 lb)	6902
β2/3000	25 kg (55 lb)	8 kg (17.6 lb)	6003 (without brake) 6202 (with brake)
β3/3000	70 kg (154 lb)	20kg (44 lb)	6205
β6/2000	70 kg (154 lb)	20kg (44 lb)	6205
βM0.5/4000 βM1/4000	20 kg (44 lb)	5 kg (11 lb)	6902
αC12/2000	450 kg (990 lb)	135 kg (297 lb)	6208

NOTES:

- The allowable radial load is the value when a load is applied to the shaft end. It indicates the total continuous force applied to the shaft in some methods of mounting (for example, belt tension) and the force by load torque (for example, moment/pulley radius).
- The belt tension is critical particularly when a timing belt is used. Belts that are too tight may cause breakage of the shaft or premature bearing failure. Belt tension must be controlled so as not to exceed the limits calculated from the permissible radial load indicated above.
- In some operating conditions, the pulley diameter or gear size needs to be checked. For example, when using the model β6/2000 with a pulley/gear with a radius of 1.5 inches (3.8 cm) or less, the radial load when 230 in-lb of peak torque is provided by the motor will exceed the 154 lb maximum rating. In the case of the timing belt, the belt tension is added to this value, making it necessary to support the shaft end.
- When using a timing belt, shaft failure or bearing overload can be minimized by positioning the pulley as close to the bearing as possible.
- Since a standard single row, deep-groove ball bearing is used for the motor bearing, a very large axial load cannot be used. Particularly when using a worm gear and a helical gear, it is necessary to provide another bearing to isolate the thrust load from the gearing.
- The motor bearing is generally fixed with a C-snap ring, and there is a small play in the axial direction. When this play influences the positioning in the case of using a worm gear and a helical gear, for example, it is necessary to use an additional bearing support.

13.6 β Series Amplifiers Dimensions

The β Series amplifiers are panel mounted devices with dimensions as shown in Figure 36HII-12. When installing the amplifiers make sure the clearances as shown in Section 13.3.

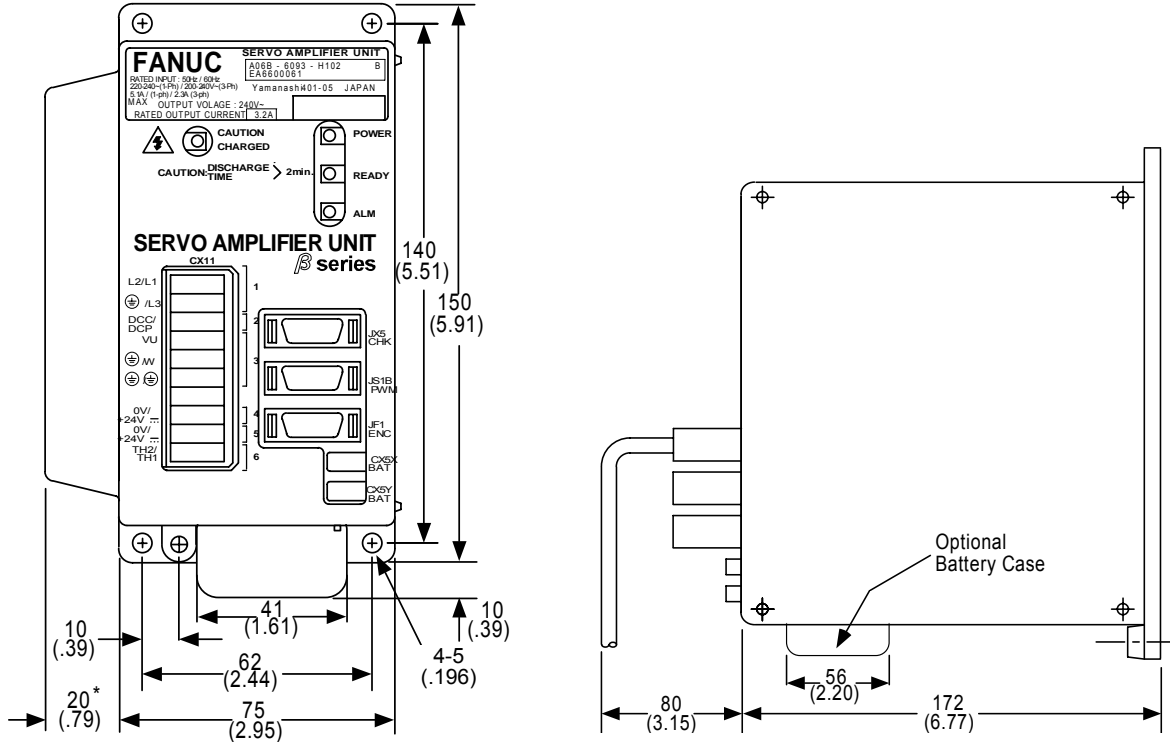

* Measurement applies to the β 20 amplifier only. The β 12 amplifier does not include the heat sink extension. Dimensions shown in mm (in).

Figure II-12. β Series servo amplifier unit, front and side views

13.7 Noise Protection

Separation of Signal and Power Lines

When routing signal and power lines, the signal lines must be separated from the power lines to ensure best noise immunity. The table below lists the types of cables used:

Table II-12. Servo amplifier signal line separation

Group	Signal	Action
A	Amplifier input power line, motor power line, MCC drive coil	Separate these cables from those of group B by bundling them separately* or by means of electromagnetic shielding**. Attach a noise preventer or suppressor, such as a spark arrester, to the MCC drive coil.
B	Cable connecting control unit with servo amplifier and serial encoder feedback cable	Separate these cables from those of group A by bundling them separately or by means of electromagnetic shielding**. In addition, shielding must be provided.

* The bundle of group A cables must be separated from the bundle of group B cables by at least 10 cm.

** Electromagnetic shielding involves shielding groups from each other by means of a grounded metal (steel) plate.

Grounding

A typical machine has three separate grounds:

- **Signal Ground:** Provides the reference potential (0 V) for the electrical signal system.
- **Frame Ground:** Ensures safety and shields external and internal noise.
- **System Ground:** Connects each unit and the inter-unit frame ground system to earth ground.

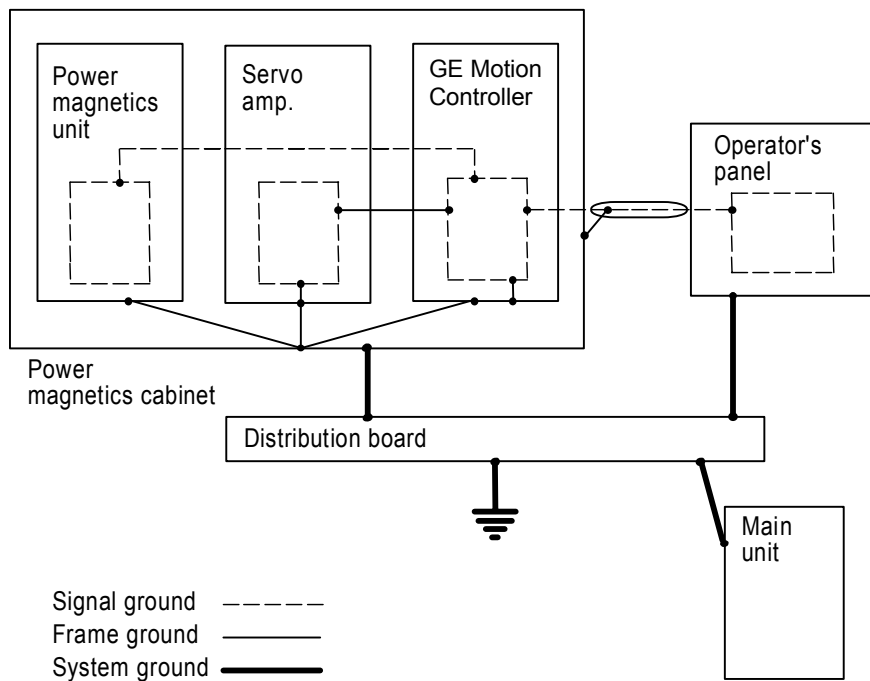

Figure II-13. Ground system

Servo Products Specification Guide

Notes on the ground system wiring:

- The ground resistance of the system ground must not exceed 100 ohms (Class-3 ground).
- System ground connection cables must have a sufficiently large cross-sectional area to enable them to safely carry the current that will arise in the event of a problem such as a short-circuit (in general, a cross-sectional area no less than that of the AC power line must be provided).
- The system ground connection cable must be integrated with the AC power line such that power cannot be supplied if the ground wire is disconnected.
- The CX11-3 grounding connector is supplied to provide the servo motor frame ground connection and should always be installed. A separate 1 meter long cable for this connection is included with the optional prefinished motor power cables.
- The motor frame must be referenced to earth ground with a class 3 (100 ohms or less) system ground. Use an ohmmeter to measure the resistance from the servomotor frame to a known earth ground rod or grid. When using the 20 amp amplifier (SVM-20i), the servo motor frame ground connection on connector CZ7-3 pin A2 should always be installed. The frame-to-ground resistance should be within 1 to 2 ohms.
- In a high noise environment, installing a ground wire on the motor frame and routing it directly to the nearest available earth ground can improve noise immunity. Some servo motors have a tapped hole on the frame or a blind hole that can be tapped. For smaller motors, connect to the motor mounting bolts.
- The Motor Power cable should not be a shielded cable. If a custom built cable with shield was used for motor power, lift the shield connection at both ends of the cable. If a shield is attached, especially at the motor end, it acts as an antenna to couple noise into the encoder.
- The Motor Feedback cable should have the Z44B295864-001 Grounding Bar and one ZA99L-0035-001 Grounding Clamp per axis installed near the amplifier. Confirm that the grounding bar is referenced to earth ground with a class 3 (100 ohms or less) system ground. Use an ohmmeter to measure the resistance from the grounding bar frame to a known earth ground rod or grid. The frame to ground resistance should be within 1 to 2 ohms.

In a high noise environment, installing a ferrous bead on the feedback cable within a short distance of the amplifier connector can also improve noise immunity.

- Separation of Motor Power and Motor Feedback cables: Group A signals (Amplifier main AC power, Motor Power Cable and MCC drive coil) signals must be separated from Group B signals (Motor Feedback cable) by at least a 10cm distance. Do not tie Group A and B signals together with cable ties or wraps at any point. An alternative is to separate these two groups by means of a grounded metal (steel) plate.
- The MCC relay used to switch the three-phase AC main power to the amplifier should have an appropriate noise (spark) arrester on its drive coil.
- The 24VDC power supply used to supply the logic power to the amplifiers should be a regulated supply free of excessive noise. If possible examine the DC voltage with an oscilloscope for noise. If a 24 VDC motor-mounted holding brake is used, it should not use the same power supply as the control logic power.

Servo Products Specification Guide

- An AC line filter is recommended to suppress high frequency line noise on the amplifier main power lines. When an isolation transformer is used to convert AC main power to amplifier input power levels, the AC line filter is not required. GE Intelligent Platforms supplies an acceptable three-phase line filter sized for 5.4KW or 10.5KW especially for this purpose. This filtered AC main power should not be shared with other equipment in the panel, especially with devices such as inverter drives or motor starters that have high power consumption.
- Amplifier Chassis Ground must be referenced to earth ground with a class 3 (100 ohm or less) system ground. Use an ohmmeter to measure the resistance from the amplifier frame to a known earth ground rod or grid. A tapped and threaded hole is provided on the amplifier frame for this purpose.
- AC Main PE Ground is supplied in accordance to local code practices and may vary, depending on AC power distribution in the facility. In general the PE ground should be referenced to an earth ground and not indicate common mode voltage to the instrumentation earth ground.

13.8 Command Cable Grounding

The controller cables that require shielding should be clamped by the method shown below. This cable clamp treatment provides both cable support (strain relief) and proper grounding of the shield. To ensure table system operation, the cable clamp method is recommended. Partially peel back the cable sheath to expose the shield. Push the clamp (ZA99L-0035-0001) over the exposed shield and insert the clamp hooks into slots on the grounding bar (Z44B295864-001). Tighten the clamp to secure cable and complete the ground connection. The grounding bar must be attached to a low impedance earth ground.

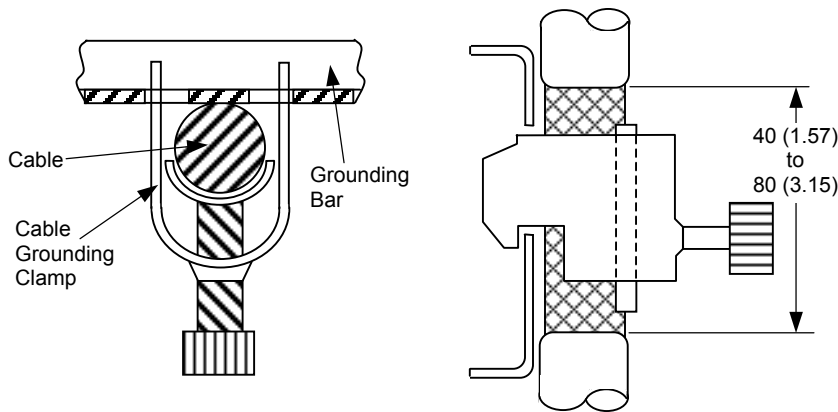

Figure II-14. Cable grounding clamp detail

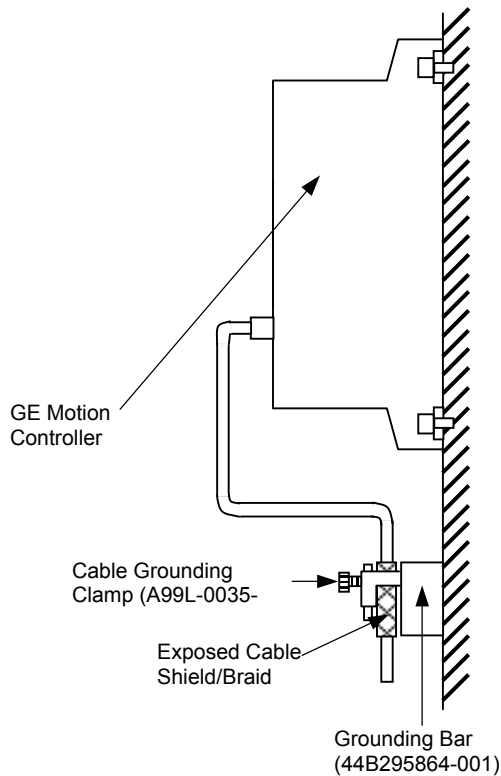

Figure II-15. Command cable shield grounding system

13.9 Selecting a Ground Fault Interrupter

The β Series servo amplifier drives a motor by means of the transistor-based PWM inverter method, in which a high-frequency leakage current flows to ground through the stray capacitance of the motor windings, power cable, and amplifier. A ground fault interrupter or leakage-protection relay, which is typically installed on the power supply side, can malfunction if such a leakage current should flow. Therefore, you should select an inverter-compatible ground fault interrupter with the following ratings to protect against the occurrence of this malfunction:

- **β 0.5/3000, β 2/3000, β 3/3000, β 6/2000, β M0.5/4000, β M1/4000:** choose a 1.8 mA commercial frequency component.
- **α C12/2000:** choose a 2.0 mA commercial frequency component.

Section 14: β Servo System Power Requirements

This section provides information about AC and DC amplifier power as well as the discharge of regenerative power.

14.1 Power Line Protection

A circuit breaker, electromagnetic contactor, and AC line filter or transformer should be installed as part of your β Series Servo system. GE Intelligent Platforms provides the AC line filter as an option. The transformer, circuit breaker, and electromagnetic contactor, however, are user-supplied components. In European countries where power sources are 380 to 400 VAC and neutral grounded, it is necessary to install a transformer or supply single-phase power.

The same incoming AC control components can be used to provide power to multiple amplifiers, as long as the components are rated for the current and power drawn by the sum of all of the amplifiers.

14.2 AC Line Filter

An AC line filter is recommended to suppress the influences of high-frequency input line noise on the drive power supply. When an isolation-type power transformer is used because a power supply voltage within the specified range is not available, an AC line filter is not required.

If two or more servo amplifiers are connected to one AC line filter, the total continuous output rating of all connected servo amplifiers should be kept below the continuous output rating of the AC line filter. The continuous output rating for the various servos are shown below.

Table II-13. β Servo Motor Continuous Output Rating

<i>Motor</i>	<i>Cont. Output Rating</i>
β 0.5/3000	0.2 kW
β 2/3000	0.5 kW
β 3/3000	0.5 kW
β 6/2000	0.9 kW
β M0.5/4000	0.2 kW
β M1/4000	0.4 kW
α C12/2000	1.0 kW

If your installation must be EMC compliant, verify that the use of an AC line filter fully satisfies the EMC requirements. You may need to select and install a user-supplied noise filter to meet EMC requirements.

Two AC line filters are available:

- 5.4 kW, 3-phase (ZA81L-0001-0083#3C)
- 10.5 kW, 3-phase (ZA81L-0001-0101#C)

For AC line filter specifications and dimension drawings, refer to [Section 6.2](#).

14.3 Circuit Breaker Selection

To provide proper protection for the amplifier, use a circuit breaker rated at no more than 20 Amps (10A for VDE 1601 compliance for CE marking). Table II-14 will help you select the appropriate circuit breaker for your motion application.

Table II-14. Currents Drawn at Continuous Rated Output

<i>Motor</i>	<i>Input Current 3-phase</i>	<i>Input Current single phase</i>
β0.5/3000	1.9 A (rms)	3.2 A (rms)
β2/3000	3.2 A (rms)	5.1 A (rms)
β3/3000	3.2 A (rms)	5.1 A (rms)
β6/2000	6.3 A (rms)	10.1 A (rms)
βM0.5/4000	0.9A (rms)	1.6A (rms)
βM1/4000	1.8A (rms)	3.2A (rms)
αC12/2000	6.3 A (rms)	10.1 A (rms)

NOTE

When multiple amplifiers are connected to a single circuit breaker, select a breaker by multiplying the sum of the currents listed in Table II-14 by 0.6.*

Example: Connecting two β6/2000 motors operating on 3-phase power:

$$(6.3 + 6.3) \times 0.6 = 7.6 \text{ Arms}$$

A standard 10 Amp circuit breaker can be used.

During rapid motor acceleration, a peak current that is three times the continuous rating flows. Select a circuit breaker that does not trip when a current that is three times the continuous rating flows for two seconds.

*This factor attempts to compensate for applications where all axes are not demanding full power at the same time. In applications where all axes are running continuously or with high duty cycles, this factor must be increased by 1.

14.4 Electromagnetic Contactor Rating

To prepare for incoming AC power, you must also select and install an appropriate electromagnetic contactor, based on the peak currents for the motors in your system. When multiple amplifiers are connected to a single circuit breaker, select a breaker based on the sum of the currents in Table II-14.

14.5 Incoming AC Power

Table II-15. AC Power

Specification	Description
Voltage: 3-phase 1-phase*	200 VAC to 240 VAC 220 VAC to 240 VAC
Frequency	50 Hz, 60Hz \pm 2 Hz
Voltage fluctuation during acceleration/deceleration	7% or less

* Single-phase operation reduces the lifetime of the servo amplifier. For β 6/2000 and α C12/2000 motors with acceleration/deceleration duty cycles greater than once every 20 seconds, 3-phase power is recommended.

AC Power Ratings

The power supply rating required when using multiple servo motors can be determined by summing the requirements of the individual motors.

The power supply ratings listed in Table II-16 are sufficient as continuous ratings. Note, however, that servo motor acceleration causes a current to momentarily flow that is approximately three times the continuous current rating.

When the power is turned on, a surge current of about 37A (when 264VAC is applied) flows for 20 msec.

Table II-16. Three-Phase Power Supply Ratings

Motor	Power Supply Rating
β 0.5/3000	0.4 kVA
β 2/3000	0.77 kVA
β 3/3000	0.77 kVA
β 6/2000	1.4 kVA
β M0.5/4000	0.2 kVA
β M1/4000	0.4 kVA
α C12/2000	1.6 kVA

14.6 Incoming DC Power

The amplifier requires a 24 VDC power supply for amplifier control power. This DC power supply must be supplied by the user.

The information in Table II-17 below will help you select the appropriate DC power supply for your motion application.

The same external DC power supply can be used to provide power to multiple amplifiers as long as the supply is rated for the sum of power drawn by all of the amplifiers. To daisy chain the amplifiers, add connection K13 between amplifiers (see the connection diagram in Section 15.3 for more details).

Table II-17. DC Amplifier Control Power Specifications

Specification	Description
Input voltage	24V DC ($\pm 10\%$)
Power supply rating (per amplifier)	0.4 amps

NOTE

The 24 VDC input is fused to protect the amplifier. The fuse labeled F600 is located below the CX11 connector when the amplifier plastic cover is removed. The replacement fuse part number is ZA06B-6073-K250 (Manufacturer: Daito LM32, DC48V, F3.2A).

A spare fuse is included with each β amplifier package (IC800BPK012 or IC800BPK020)

14.7 Discharging Regenerative Energy

Regenerative energy is normally created in applications with a high load inertia or frequent acceleration and deceleration. When decelerating a load, the stored kinetic energy of the load causes generator action in the motor causing energy to be returned to the β Series amplifier. For light loads and low acceleration rates, the amplifier may be able to absorb this energy. Otherwise, an optional external regenerative discharge unit must be installed.

Two separate 30 Ohm regenerative discharge units are available with ratings of 100 W and 20 W. The 100 W unit (ZA06B-6093-H402) is panel-mounted, whereas the 20 W unit (ZA06B-6093-H401) mounts to the tapped holes on the side of the amplifier heat sink. Calculations shown later in this section can be used to determine the need for an external unit.

If the regenerative discharge unit overheats, a built-in thermostat is tripped, the external overheat alarm is issued, and the motor is stopped. If an external regenerative discharge unit is required, a separate unit must be installed for each amplifier. This component cannot be daisy-chained. The dimensions for these units are shown in the following drawings. Connections are shown for cables K7 and K8 in Section 15.3 of this document.

Calculating the Average Regenerative Energy

Use the following calculation to determine the average regenerative energy that will be released in your application (ambient temperature is assumed not to exceed 55°C). Based on the calculations select either the 20 W or 100 W regeneration resistor. The wattage rating of the selected resistor must exceed the average calculated regenerative energy from the equation below:

$$\text{Average Regenerative Energy (Joules)} = \text{Rotational Energy to be Released during Deceleration (STEP 1)} - \text{Energy to be Consumed Through Axis Friction (STEP 2)} + \text{(only in vertical axis operation) Vertical Energy to be Released During Downward Motion (STEP 3)}$$

STEP 1: Rotational Energy to be Released during Deceleration

$$= (6.19 \times 10^{-4}) \times (J_m + J_L) \times \omega_m^2 \text{ Joules}$$

where:

J_m	Motor rotor inertia	(lb-in-s ²)
	$\beta 0.5 = 0.00016$	
	$\beta 2 = 0.00581$	
	$\beta 6 = 0.0347$	
	$\alpha C12 = 0.0555$	
J_L	Load inertia converted to motor shaft inertia	(lb-in-s ²)
ω_m	Maximum motor speed at time of deceleration	(rpm)

STEP 2: Energy to be Consumed through Axis Friction

$$= (5.91 \times 10^{-3}) \times t_a \times \omega_m \times T_L \text{ where:}$$

ω_m	Motor speed during rapid traverse	(rpm)
t_a	Acceleration/deceleration duration during rapid traverse	(sec)
T_L	Axis friction torque (converted to motor shaft torque)	(lb-in)

STEP 3: Vertical Energy to be Released During Downward Motion

(This term applies only in vertical axis operation)

$$= (1.182 \times 10^{-2}) \times T_h \times \omega_m \times \frac{D}{100} \text{ where:}$$

T_h	Upward supporting torque applied by the motor during downward rapid traverse	(lb-in)
ω_m	Motor speed during rapid traverse	(rpm)
D	Duty cycle of downward vertical operation during rapid traverse	(%)

(Note: the maximum value of D is 50%. D assumes a smaller value)

Servo Products Specification Guide

STEP 4: Determine if a Regenerative Discharge Unit Is Required

Determine the Average Regenerative Energy using the equation in the beginning of this section.

When the average regenerative energy produced never exceeds the amounts that is indicated in Table II-18 below, a separate regenerative discharge unit is **not** required:

Table II-18. Maximum Allowable Regenerative Energy for Amplifiers

<i>Amplifier</i>	<i>Max. Allowable Regen. Energy</i>	<i>Used with Motors</i>
βSVU-12	13 Joules	β0.5, β2
βSVU-20	16 Joules	β3, β6, αC12, βM0.5, βM1

If the calculated value exceeds the storage capability of the amplifier, then an external regenerative discharge unit is required (see Step 5).

STEP 5: Selecting a Regenerative Discharge Unit

If a separate regenerative discharge unit is required, the following calculation will determine whether the 20 W or 100 W unit is required:

Average Regenerative Power (W) = Average Regenerative Energy (Joules) $\times \frac{1}{F}$ where:

F = Deceleration duty (seconds) Example: deceleration once per 5 second cycle, F=5

Select a regenerative resistor with a rating that exceeds the average regenerative power. If this value is greater than 100 W, contact GE Intelligent Platforms for assistance.

Example:

Assume a horizontal axis using a β2 motor ($J_m = 0.00581 \text{ lb-in-s}^2$) that decelerates once every 6 seconds (F) for 0.2 seconds (t_a) with a maximum speed of 2000 RPM (ω_m). The machine inertia (J_L) is 0.0139 lb-in-s^2 .

STEP 1: Rotational Energy = $(6.19 \times 10^{-4}) \times (0.00581 + 0.0139) \times 2000^2 = 54.4 \text{ Joules}$

STEP 2: Assuming $T_L = 10 \text{ in-lb}$:

Friction Energy = $(5.91 \times 10^{-3}) \times 0.2 \times 2000 \times 10 = 23.64 \text{ Joules}$

Therefore:

STEP 4: Average Regenerative Energy = $54.4 - 23.64 = 30.76 \text{ Joules}$

Because the 30.76 Joules required is more than the 13 Joules allowed by the βSVU-12 amplifier used with the β2 motor, a regenerative resistor is required.

STEP 5: Since the application requires decelerations every 6 seconds, $\frac{1}{F} = \frac{1}{6}$

Average Regenerative Power = $30.76 \text{ Joules} / 6 \text{ seconds} = 5.13 \text{ W}$

Therefore, the 20 W resistor (ZA06B-6093-H401) is adequate for this application.

Section 15: β Servo System Connection

When planning your system, it is important to determine how the different parts of the system connect together. Cable reference numbers K1 through K15 on the β Servo Connection Diagram on p. 35. Details for each connection are shown in Section 15.3.

15.1 System Connections

β Series motor and amplifier connectors required for the system are available from GE Intelligent Platforms.

GE Intelligent Platforms supplies connectors to allow you to manufacture cables to the specific length required by your system design. GE Intelligent Platforms also offers finished cables as options for many connections. See the Cable Connections chart on p. 32 for more information.

A connector kit (Part number ZA06B-6093-K305) and an E-Stop connector (ZA02B-0120-K321) are shipped with each β Series servo amplifier package. Kit components are not sold separately. The contents of the connector kits are described below:

Table II-19. β Connector Kit Contents, ZA06B-6093-K301 (Amplifier Version G or Lower)

Qty.	FANUC Part Number	Description	Wire Gauge
3	A63L-0001-0460/025KD	CX11-3 (Ground), CX11-4, -5 (24 VDC) single wide connectors	NA
2	A63L-0001-0460/045KD	CX11-1 (Power), CX11-3 (Motor Power) double wide connectors	NA
10	A63L-0001-0456/ASL	CX11 contacts	18—16 AWG (0.12mm ² —0.5mm ²)
4	A63L-0001-0456/ASM	CX11 contacts	18—16 AWG (0.12mm ² —0.5mm ²)
1	A660-8011-T604	CX11-6 prewired jumper for discharge resistor thermal switch (must be used when external discharge resistor is not installed)	NA

Table II-20. β Connector Kit Contents, ZA06B-6093-K305 (Amplifier Version H or Higher)

Qty.	Tyco Electronics AMP Part Number	Description	Wire Gauge
1	175363-3	CX11-1 (Power) double wide connector	NA
1	1318182-2	CX11-2 (Dummy housing for applications when no regenerative discharge resistor is used) single wide connector	NA
1	1318095-2	CX11-3 (Motor Power) triple wide connector	N/A
2	175362-1	CX11-4 & CX11-5 (24VDC Power) two single wide connectors	N/A
10	A63L-0001-0456/ASL	CX11 contacts	18—16 AWG (0.12mm ² —0.5mm ²)
4	A63L-0001-0456/ASM	CX11 contacts	18—16 AWG (0.12mm ² —0.5mm ²)
1	A660-8011-T604 (FANUC p/n)	CX11-6 prewired jumper for discharge resistor thermal switch (must be used when external discharge resistor is not installed)	NA

Servo Products Specification Guide

Caution

When no regenerative discharge resistor is used, installation of a dummy housing (1318182-2) is recommended for prevention of wrong insertion. Do not make a connection between the pins (A and B) of CX11-2. Otherwise, the amplifier can be damaged.

Note: The following hand tool, which is available from Tyco Electronics (<http://www.tycoelectronics.com>), is required for installing the connectors:

Crimp Tool **58571-1** with die **58571-2** (die is installed in the tool at factory).

Optional connectors are also available for the various motor power and feedback cables.

Table II-21. Available Motor Power and Feedback Cable Connectors for β Servo Systems

<i>Part Number</i>	<i>Description</i>
ZA06B-6050-K119	Motor Power Connector Kit, β 0.5/3000
Z44A730464-G18	Motor Power Connector Kit, β 2/3000, β 3/3000 and β 6/2000
ZA06B-6050-K120	Motor Encoder Connector Kit, β 0.5/3000
ZA06B-6050-K115	Motor Encoder Connector Kit, β 2/3000, β 3/3000 and β 6/2000
ZA06B-6050-K214	β Series Amplifier Encoder Feedback Connector Kit (JF1)
Z44A730464-G26	Motor Brake Connector Kit (not required for β 0.5 motor with brake)

Servo Products Specification Guide

Table II-22. Cable Connections

Ref.	Connects	Prefinished Cable Part Number	Connection Type	When Required
K1	DSM302 to Amplifier (JS1B)	IC800CBL001 (1m) IC800CBL002 (3m)	Servo Command Signal	always
K1	All other GE Intelligent Platforms Controllers to Amplifier (JS1B)	IC800CBL003 (2m)	Servo Command Signal	
K2	Built in Serial Motor Encoder to Amplifier (JF1)	IC800CBL022 severe duty, 14m (β 0.5/3000) IC800CBL023 severe duty, 14m (β 2/3000, β 3/3000, β 6/2000) CF3A-2MPB-0140-AZ severe duty, 14m (α C12/2000)	Motor Encoder Feedback	always
K3	AC Power Components to Amplifier	N/A	3 Phase Servo Power	always
K4	Amplifier to Motor (Prefinished cable includes separate cable to connect motor frame ground to customer's earth ground.)	IC800CBL067, 14m (β 0.5/3000) IC800CBL068, 14m (β 2/3000, β 3/3000, β 6/2000) CP4B-1MPB-0140-AZ, 14m (α C12/2000)	Motor Power	always
K5	Servo Amplifier Emergency Stop Input (JX5) to Machine E-Stop Contact	N/A	Emergency Stop	always
K7	Amplifier to Regenerative Discharge Unit	N/A (included with regenerative discharge unit)	Regenerative Power Discharge	in most cases ¹
K8	Regenerative Discharge Unit Over Temperature Switch to Amplifier	N/A (included with regenerative discharge unit)	Regenerative Power Discharge	in most cases ¹
K9	Amplifier (CX5) to Backup Battery Holder	N/A	Absolute Encoder Battery	with battery option ²
K10	Control to MCC Coil	N/A	Emergency Stop/Power Enable	control-dependent; consult your control documentation
K12	External 24 VDC Power Supply to Amplifier	N/A	24 VDC Amplifier Power	always
K13	Amplifier to Second Amplifier	N/A	24 VDC Amplifier Power	when daisy chaining amplifiers
K14	90 VDC Brake Power Supply to Motor Brake	Z44C742238-004. 14m (β 2/3000, β 3/3000, β 6/2000, α C12/2000)	Motor Brake Power	with brake option ³
K15	MCC Contact to Control	N/A	Control Enable	always

¹ See Discharging Regenerative Energy in Section 14.7

² Prefinished cable is provided as a part of a battery pack option

³ Prefinished motor power cables supplied by GE Intelligent Platforms for β 0.5/3000 motor includes brake wiring.

15.2 β Series Connection Diagram

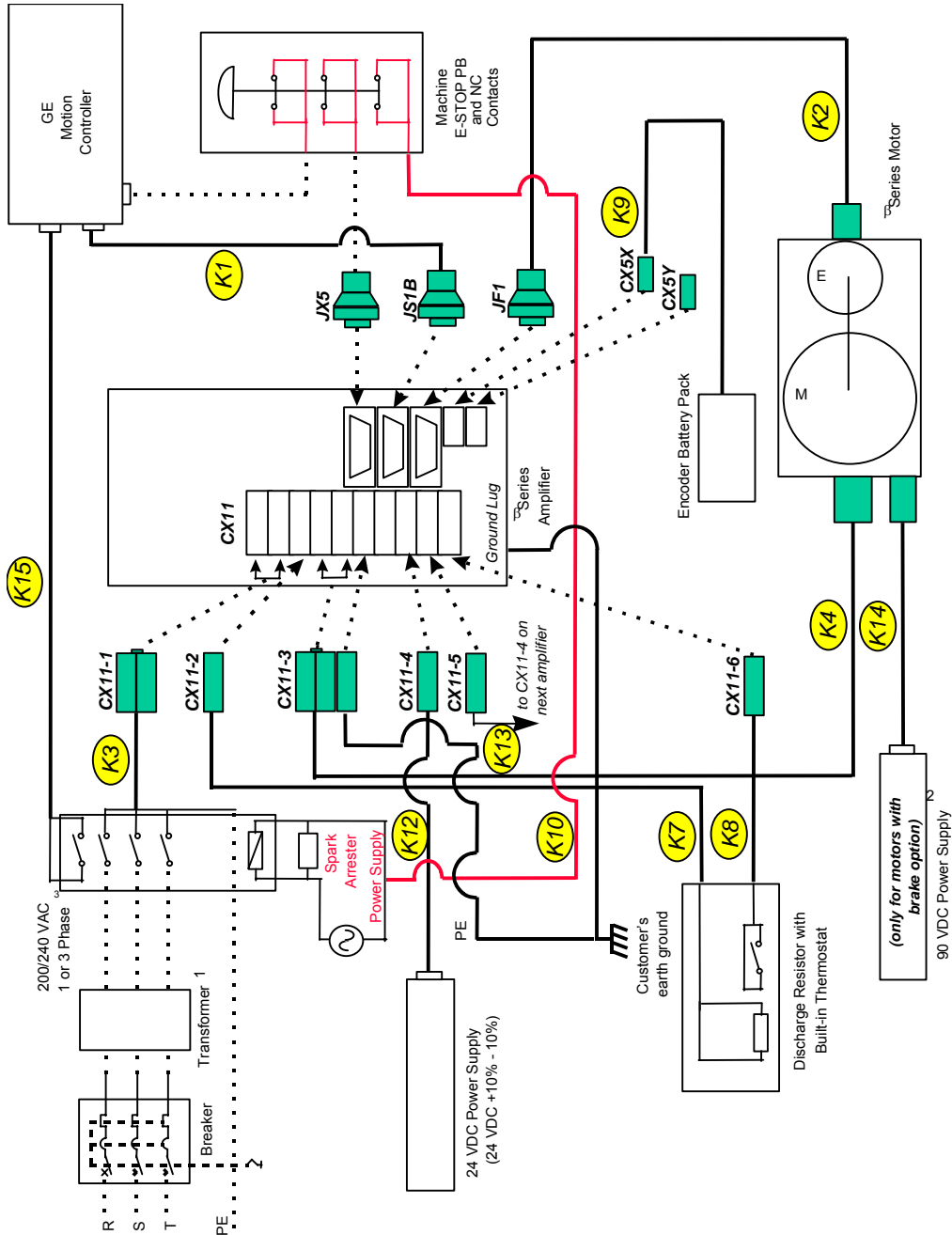

KEY:

- available GE Intelligent Platforms cable
- user-supplied cable

Figure II-16. Cable connection diagram

¹ Line filter and lightning surge absorber can be used in place of a transformer when 200–240 VAC is available to the cabinet.
² Refer to the note in Section 10.3 regarding the motor holding brake.
³ For single-phase operation, AC line phase T is not connected. Refer to the Servo System Specifications in Section 11: for output current derating.

15.3 Connection Details

K1— Servo Command Signal Cable ($\beta 0.5/3000$, $\beta 2/3000$, $\beta 3/3000$, $\beta 6/2000$, $\alpha C12/2000$)

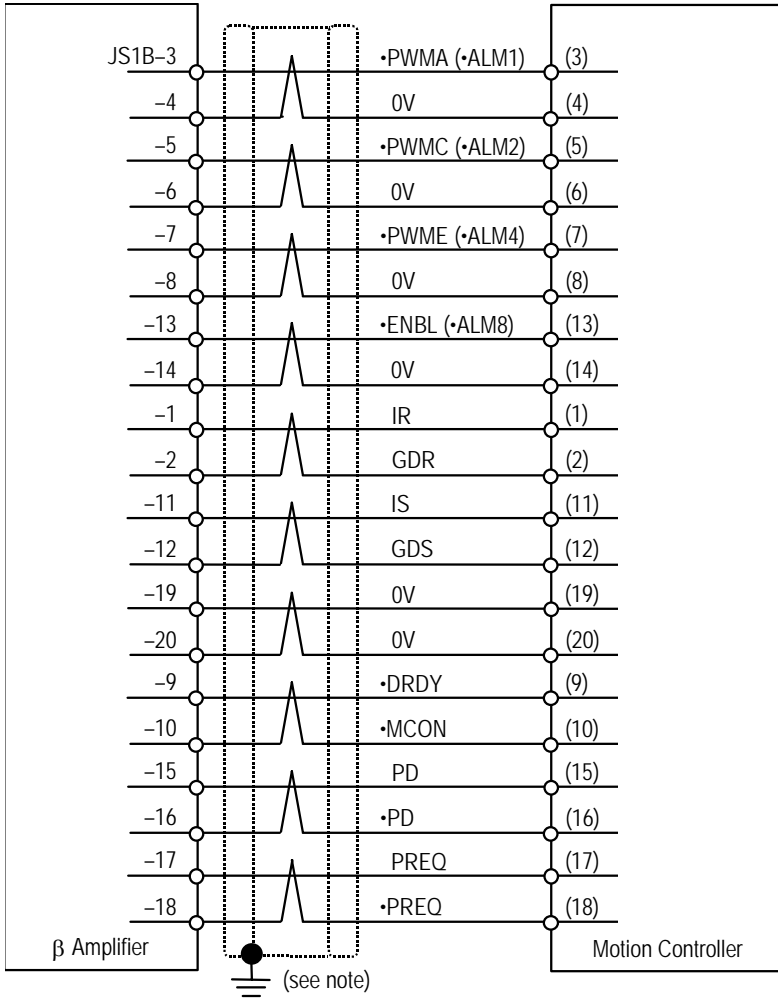

NOTES

The servo command cables for the DSM302 and DSM314 controllers (IC800CBL001 and IC800CBL002) must be purchased from GE Intelligent Platforms. Proper tooling is required to assemble the connectors. For custom length cables, contact your GE Intelligent Platforms Distributor or Sales Engineer.

Grounding the cable shield using the grounding bar (Z44B295864-001) and cable grounding clamp (ZA99L-0035-0001) will provide greater noise immunity.

- Wire: 0.08mm² twisted pair group shielded cable (10 pairs). The following wire is recommended for the K1 cable: 28 AWG x 10 pairs (20 conductors).

Servo Products Specification Guide

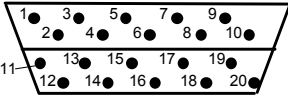
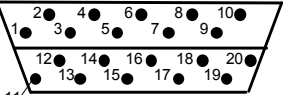
Cable (K1)	GE Intelligent Platforms Part No.	Connector Manufacturer
DSM302 to Servo Amplifier (JS1B)	IC800CBL001 (1 meter) IC800CBL002 (3 meter)	Cable must be purchased from GE Intelligent Platforms (connectors not sold separately)*
GE Intelligent Platforms controller other than DSM302 to Servo Amplifier (JS1B)	IC800CBL003 (2 meter)	<p>Hirose Electric Co., Ltd.</p>  <p>Honda Tsushin Kogyo Co., Ltd. (PCR-E20FA)</p>  <p><i>Connectors viewed from back (solder/crimp side).</i></p>

***NOTE:** DSM302 cables cannot be customer-manufactured and uses a 36-pin connector on its end. The DSM302 module requires IC693ACC355 Axis Terminal Board and either IC693CBL324 (1 meter) or IC693CBL325 (3 meter) Terminal Board Cable to access axis I/O such as Home Switch Input, Over Travel Inputs, or Strobe (registration) Inputs.

K2—Motor Encoder Feedback Cable (β0.5/3000)

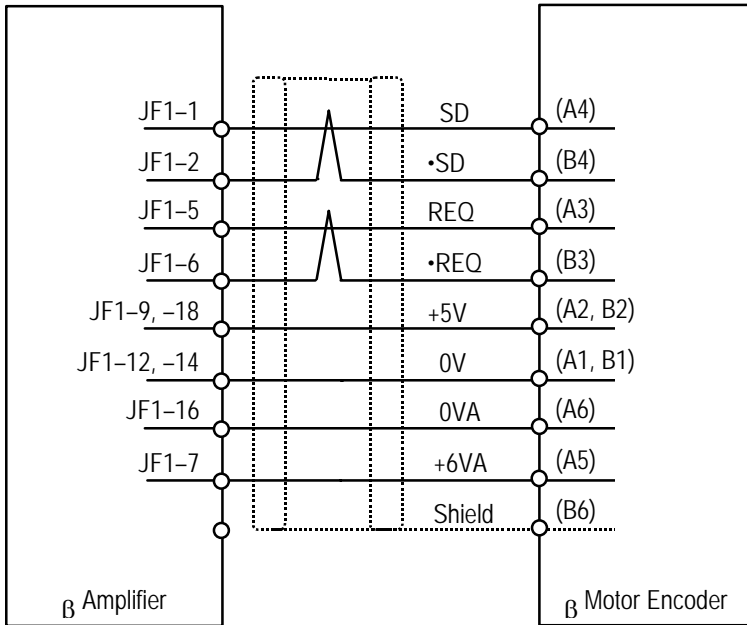

- Prefinished 14m Cable, Part number: IC800CBL022
- Wire: for +5V, 0V use two parallel conductors of 0.5mm² (20 AWG) or larger when the wire length does not exceed 14m. When the wire length exceeds 14m, wire gauge must be increased to ensure that the sum of the electrical resistance of 0V and 5V circuit does not exceed 0.5 ohms. For 6VA, 0VA use 0.5mm² (20 AWG) or larger; for SD, *SD, REQ, *REQ use 0.18mm² (24 AWG) or larger twisted pair with 60% braid shield.

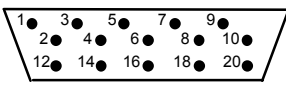
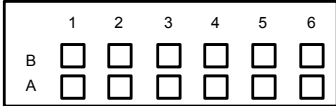
Connector	GE Intelligent Platforms Part No.	Manufacturer
Servo Amplifier (JF1)	ZA06B-6073-K214	Hirose Electric Co., Ltd. (connector:FI40-2015S) (connector cover: F1-20-CV)  Connector viewed from back (solder/crimp) side.
Servo Motor Encoder	ZA06B-6050-K120	AMP (connector: 178289-6 pin: AMP 1-175217-2) 

K2—Motor Encoder Feedback Cable (β 2/3000, β 3/3000, β 6/2000)

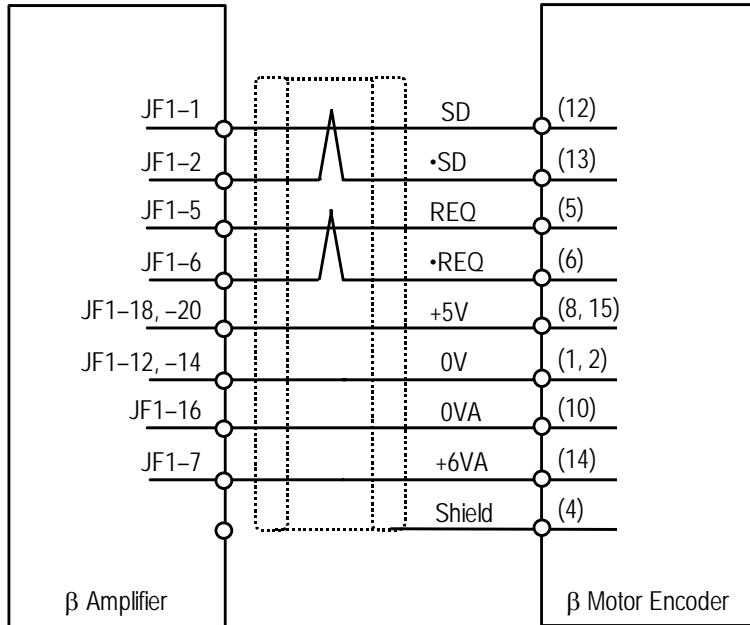

- Prefinished 14m Cable, Part number: IC800CBL023 (severe duty)
- Wire: for +5V, 0V use two parallel conductors of 0.5mm² (20 AWG) or larger when the wire length does not exceed 14m. When the wire length exceeds 14m, wire gauge must be increased to ensure that the sum of the electrical resistance of 0V and 5V circuit does not exceed 0.5 ohms. For 6VA, 0VA use 0.5mm² (20 AWG) or larger; for SD, *SD, REQ, *REQ use 0.18mm² (24 AWG) or larger twisted pair with 60% braid shield.

Connector	GE Intelligent Platforms Part No.	Manufacturer	
Servo Amplifier (JF1)	ZA06B-6073-K214	Hirose Electric Co., Ltd. (connector: FI40-2015S) (connector cover: FI-20-CV)	
Servo Motor Encoder	ZA06B-6050-K115	Hirose Electric Co., Ltd. (HDAB-15S) [connector cover: HDAW-15-CV (waterproof), HAD-CTH]	
<i>Connectors viewed from back (solder/crimp side).</i>			

NOTE

Cable includes two M4 x 12mm screws and captive lock washers for securing connector to motor encoder housing.

K2—Motor Encoder Feedback Cable (αC12/2000)

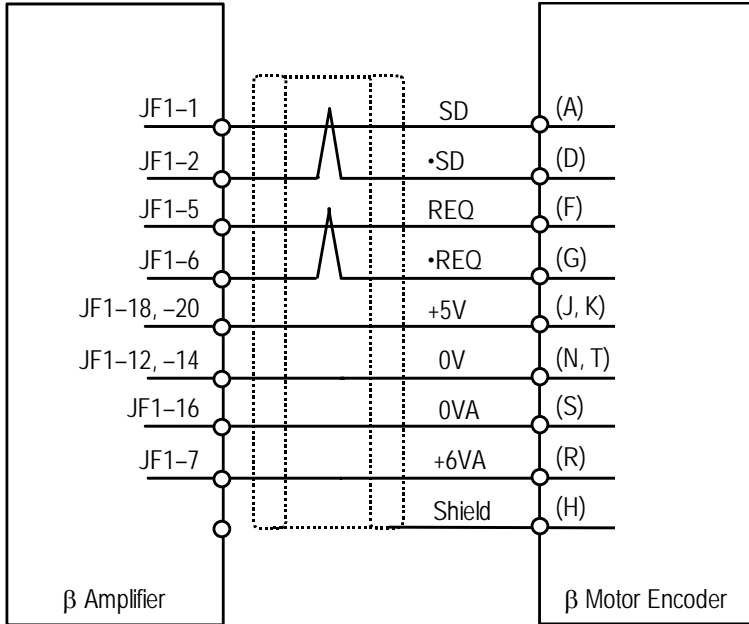

- Prefinished 14m Cable, Part number: IC800CBL021 (severe duty)
- Wire: for +5V, 0V use two parallel conductors of 0.5mm² (20 AWG) or larger when the wire length does not exceed 14m. When the wire length exceeds 14m, wire gauge must be increased to ensure that the sum of the electrical resistance of 0V and 5V circuit does not exceed 0.5 ohms. For 6VA, 0VA use 0.5mm² (20 AWG) or larger; for SD, *SD, REQ, *REQ use 0.18mm² (24 AWG) or larger twisted pair with 60% braid shield.

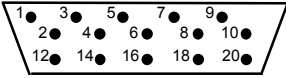
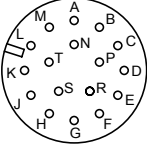
Connector	GE Intelligent Platforms Part No.	Manufacturer
Servo Amplifier (JF1)	ZA06B-6073-K214	Hirose Electric Co., Ltd. (F140-2015S) [connector cover: FI-20-CV]  Connector viewed from back (solder/crimp side).
Servo Motor Encoder	Z44A730464-G38 (CE EXT GND pin type)	Hirose Electric Co., Ltd. (MS3106A 20-29SW, straight) (MS3108B 20-29SW, elbow) 

Servo Products Specification Guide

K3—Three-Phase Servo Power Cable (user-supplied)

For a power supply voltage of 200/220/230/240 VAC 50/60 Hz (220 VAC minimum for single-phase)

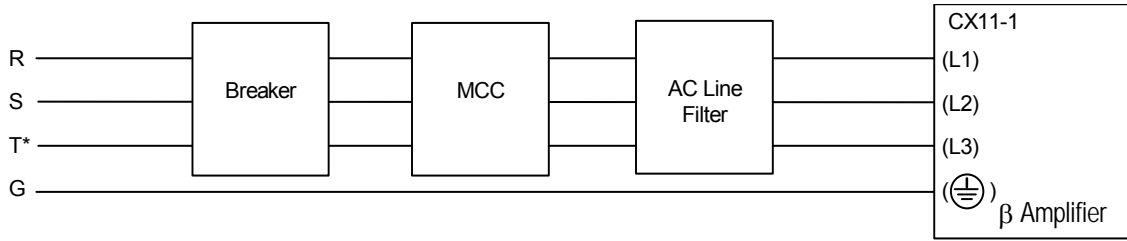

Main Power Supply

* For single-phase operation, phase T is not connected

- Wire: 600V, 4-conductor, 1.0mm² (18 AWG) or larger. For sourcing multiple amplifiers from the same AC supply, size conductors based on the sum of the current for all amplifiers (see specifications in Section 11:



Connector	GE Intelligent Platforms Part No.	Manufacturer
Servo Amplifier (Version G or lower) CX11-1	Part of Kit ZA06B-6093-K301	Nihon AMP (175363-1 Housing; 1-175218-2 Contact)
Servo Amplifier (Version H or higher) CX11-1*	Part of Kit ZA06B-6093-K305	Nihon AMP (175363-3 Housing; 1-75218-2 Contact)

* The CX11-1 connector contained in the K305 kit is not compatible with β Series amplifiers prior to revision letter H.

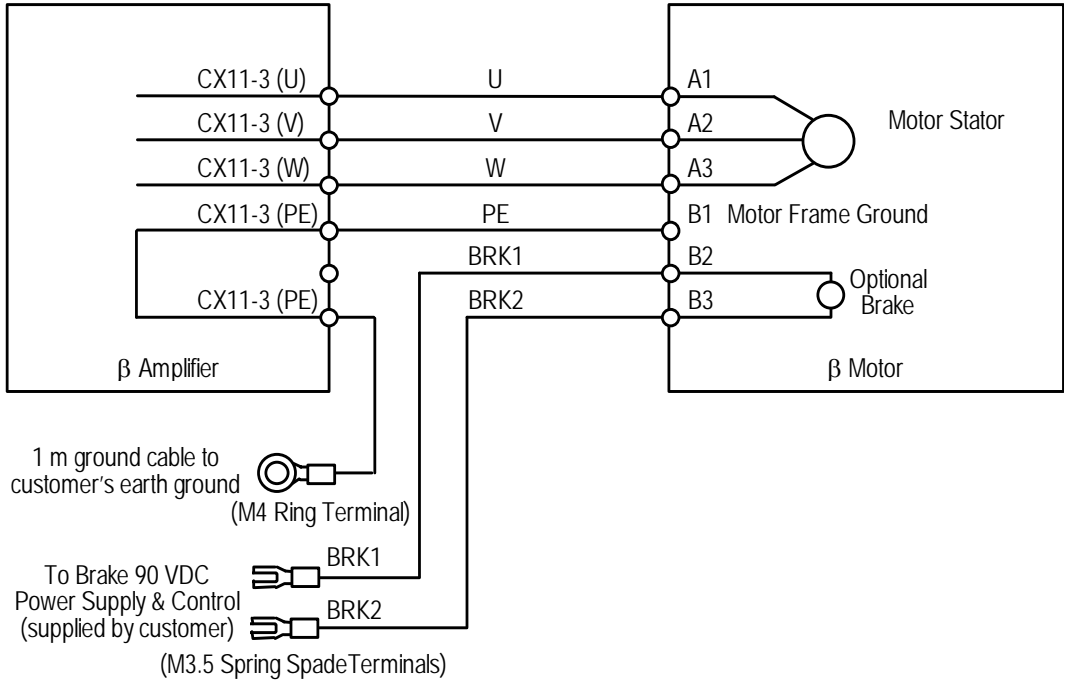
K4—Motor AC Power Cable (β0.5/3000)



- Prefinished 14m Cable, Part number: IC800CBL064 (severe duty)
- Wire: 300V, 6-conductor, 20 AWG (finestrand) 80°C, polyurethane jacket with PVC conductors (nominal cross-sectional area 0.75mm²). Ground wire is 18 AWG, 300 V, 1-conductor, 80°C, PVC, green with yellow stripe.

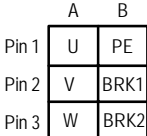

Connector	GE Intelligent Platforms Part No.	Manufacturer
Servo Amplifier CX11-3 (motor power)	Part of Kit ZA06B-6093-K301 (AMP version G or lower) ZA06B-6093-K305 (AMP version H or higher)	Nihon AMP (Housing: 175363-1; Contact: 1-175218-2) 
Servo Amplifier CX11-3 (ground)	Part of Kit ZA06B-6093-K301 (AMP version G or lower) ZA06B-6093-K305 (AMP version H or higher)	Nihon AMP (Housing: 175362-1; Contact: 1-175218-2) 
Servo Motor	ZA06B-6050-K119	Nihon AMP (Housing: 3-178129-6; Contact: 1-175217-2) 

Servo Products Specification Guide

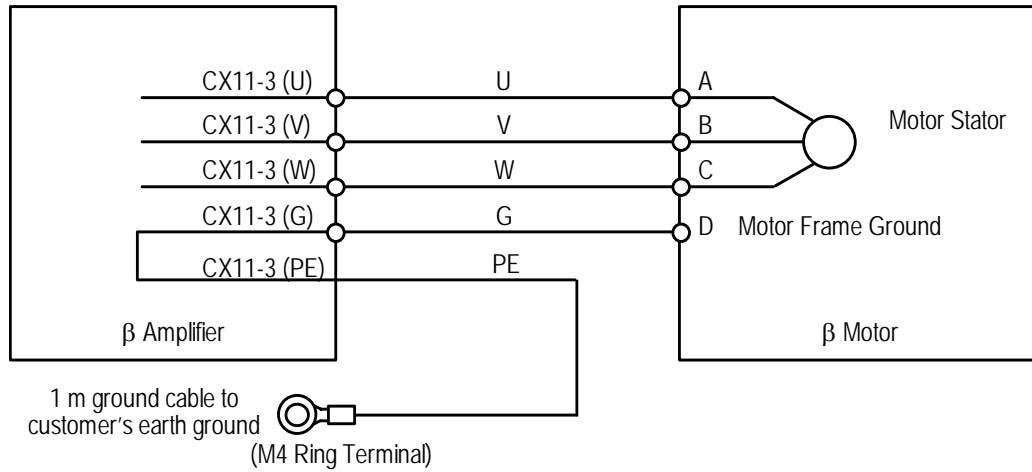
K4—Motor AC Power Cable (β2/3000, β3/3000, β6/2000)



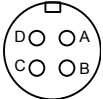

- Prefinished 14m Cable, Part number: IC800CBL065 (severe duty)
- Wire: 300V, 4-conductor, 18 AWG (finestrand) 80°C, polyurethane jacket (PUR) with PVC conductors (nominal cross-sectional area 0.75mm²). Ground wire is 18 AWG, 300 V, 1-conductor, 80°C, PVC, green with yellow stripe.

Connector	GE Intelligent Platforms Part No.	Manufacturer
Servo Amplifier CX11-3 (motor power)	Part of Kit ZA06B-6093-K301 (AMP version G or lower) ZA06B-6093-K305 (AMP version H or higher)	Nihon AMP (Housing: 175363-1; Contact: 1-175218-2) 
Servo Amplifier CX11-3 (ground)	Part of Kit ZA06B-6093-K301 (AMP version G or lower) ZA06B-6093-K305 (AMP version H or higher)	Nihon AMP (Housing: 175362-1; Contact: 1-175218-2) 
Servo Motor	Customer-made cable: Z44A730464-G18 (CE EXT GND pin)	

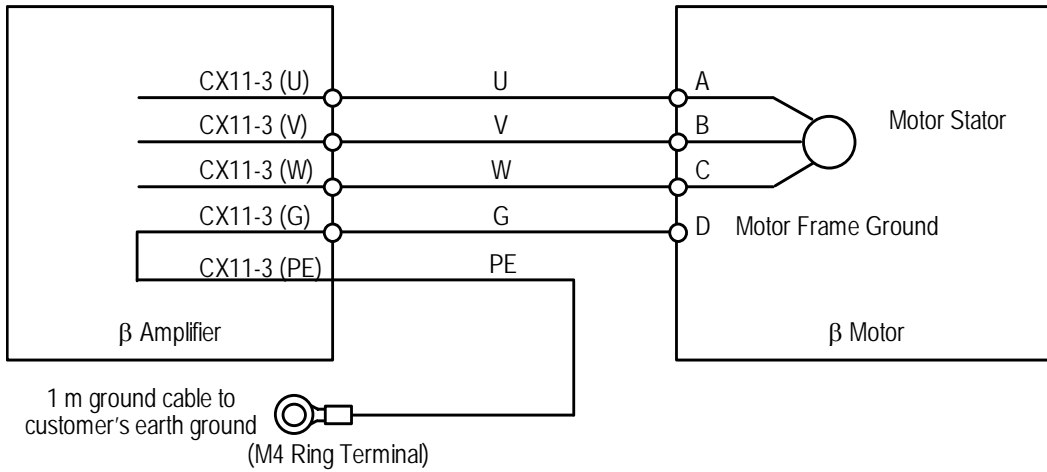
K4—Motor AC Power Cable (αC12/2000)



- Prefinished 14m Cable, Part number: IC800CBL066
- Wire: 300V, 4-conductor, 18 AWG (finestrand) 80°C, polyurethane jacket with PVC conductors (nominal sectional area 0.75mm²). Ground wire is 18 AWG, 300 V, 1-conductor, 80°C, PVC, green with yellow stripe.

Connector	Part No.	Maker
Servo Amplifier CX11-3 (motor power)	Part of Kit ZA06B-6093-K301 (AMP version G or lower) ZA06B-6093-K305 (AMP version H or higher)	Nihon AMP (Housing: 175363-1; Contact: 1-175218-2) 
Servo Amplifier CX11-3 (ground)	Part of Kit ZA06B-6093-K305 (AMP version G or lower) ZA06B-6093-K305 (AMP version H or higher)	Nihon AMP (Housing: 175362-1; Contact: 1-175218-2) 
Servo Motor	Customer-made cable: Z44A730464-G20 (CE EXT GND pin)	

Servo Products Specification Guide

K5—Servo Amplifier Emergency Stop Connection

If two to six amplifier units are used in the same system, the emergency stop signal must be connected as shown below:

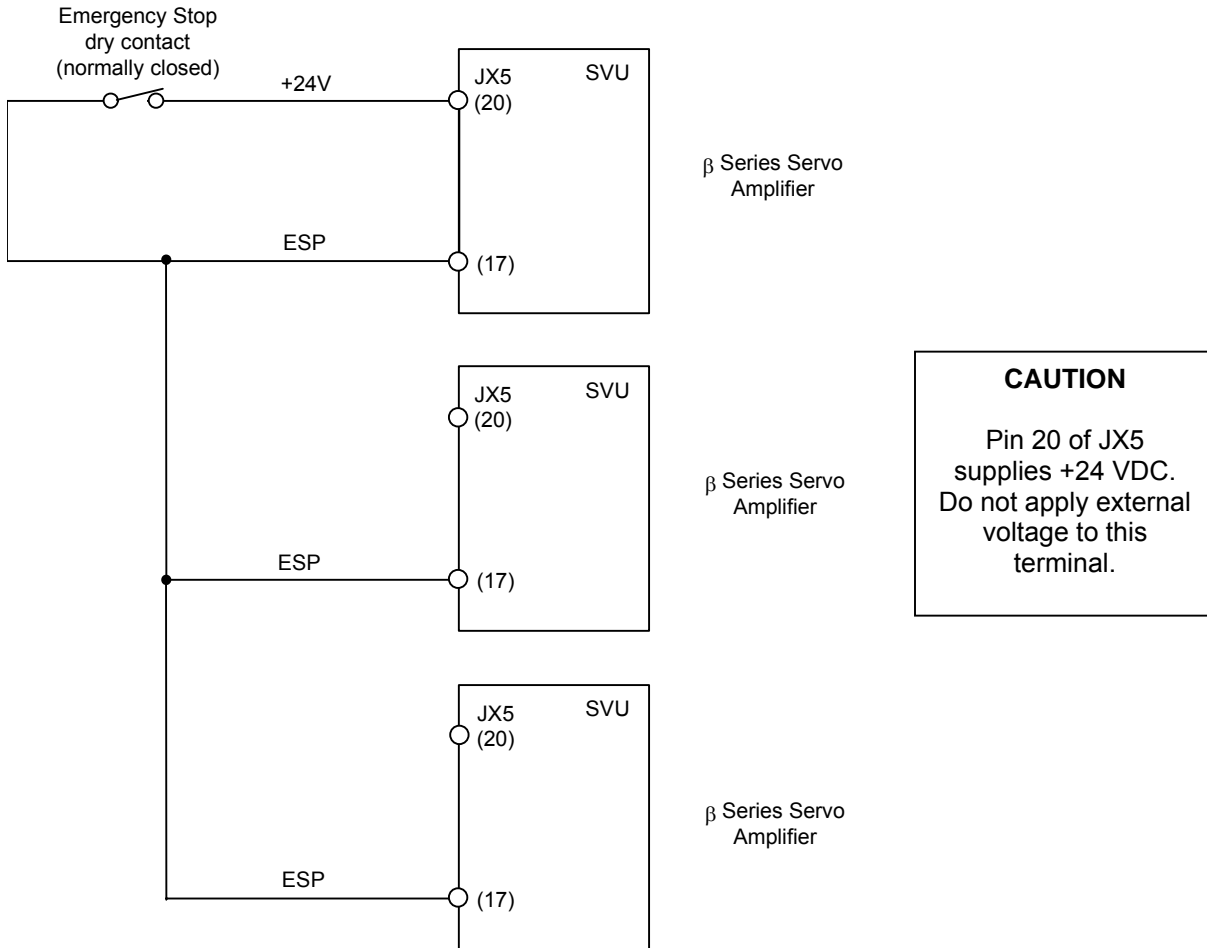

Connector	GE Intelligent Platforms Part No.	Manufacturer
JX5	ZA02B-0120-K301	<p>Hirose Electric Co., Ltd. (F140-2015S; F1-20-CV cover)</p> <p>Honda Tsushin Kogyo Co., Ltd. (PCR-E20FA)</p> <p>Connectors viewed from back (solder/crimp side).</p>

K7—Regenerative Power Discharge Cable (β 2/3000, β 3/3000, β 6/2000, α C12/2000)
K8—Regenerative Power Discharge Thermal Protection Cable

(Resistor includes amplifier connectors and contacts)

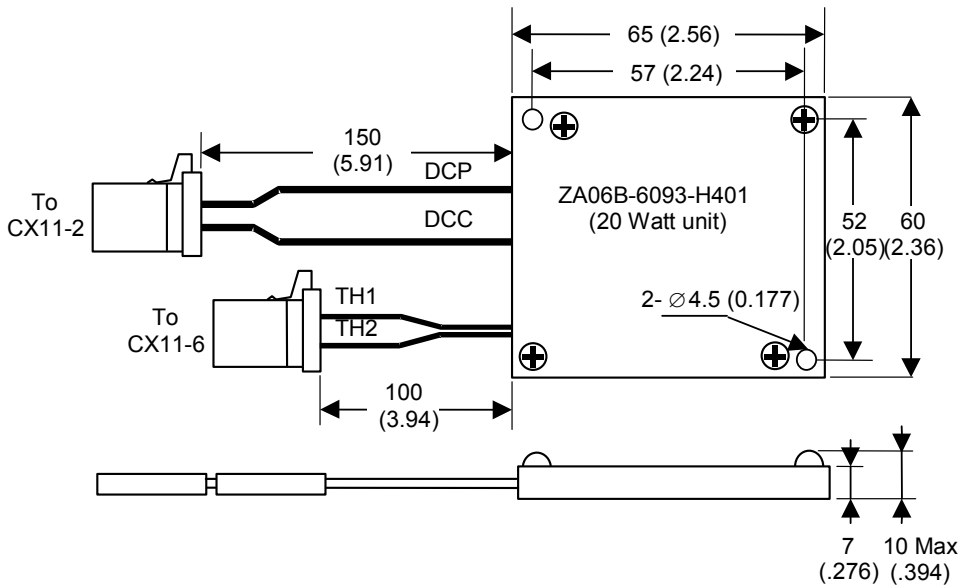
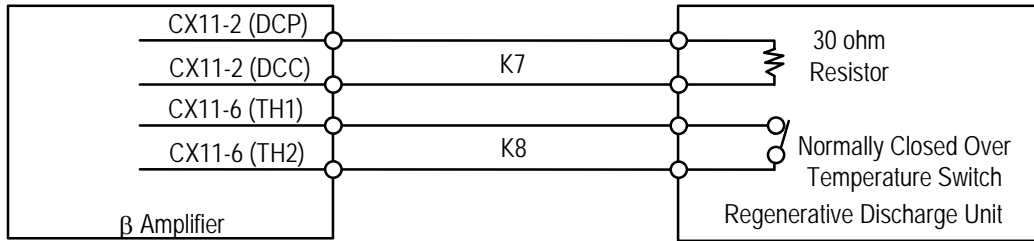

NOTE
Resistor kit contains two standoffs and mounting hardware

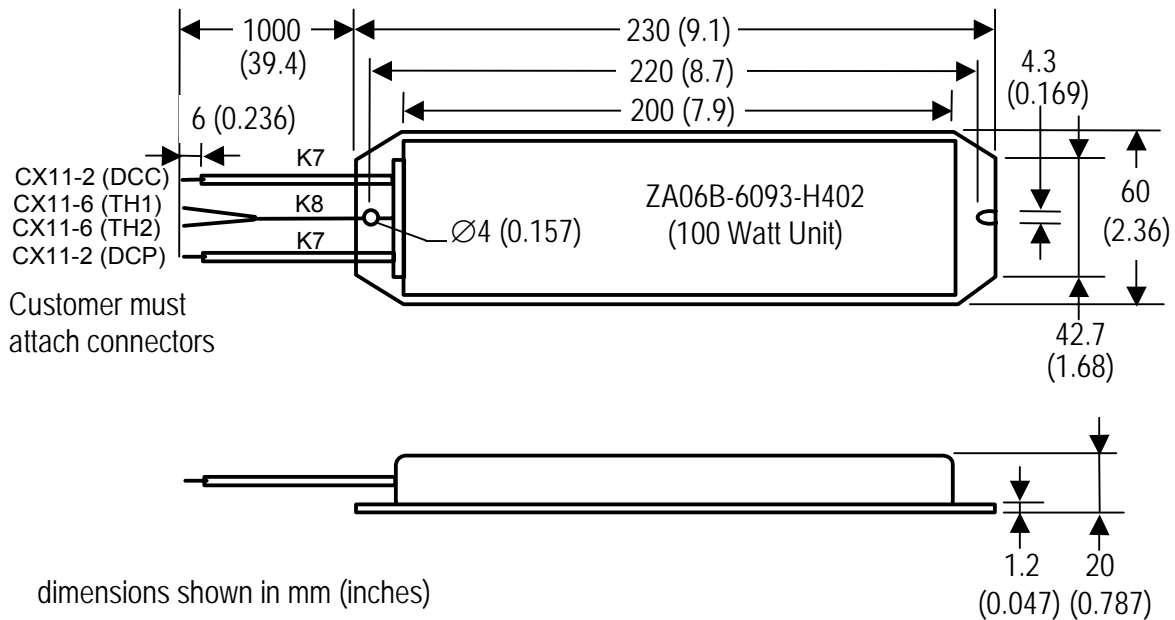

Servo Products Specification Guide

Connector	GE Intelligent Platforms Part No.	Manufacturer
Servo Amplifier CX11-2, -6	Included with Resistor Kit	Nihon AMP (Housing: 175362-1; Contact: 1-175218-2) <div style="display: flex; justify-content: space-around; align-items: center;"> <div style="text-align: center;"> <div style="border: 1px solid black; width: 20px; height: 10px; margin: 0 auto;"></div> <div style="border: 1px solid black; padding: 2px; width: 40px; margin: 2px auto;">DCP</div> <div style="border: 1px solid black; padding: 2px; width: 40px; margin: 2px auto;">DCC</div> </div> <div style="text-align: center;"> <div style="border: 1px solid black; width: 20px; height: 10px; margin: 0 auto;"></div> <div style="border: 1px solid black; padding: 2px; width: 40px; margin: 2px auto;">TH1</div> <div style="border: 1px solid black; padding: 2px; width: 40px; margin: 2px auto;">TH2</div> </div> </div>

K9—Absolute Encoder Battery Cable (β 0.5/3000, β 2/3000, β 3/3000, β 6/2000, α C12/2000)

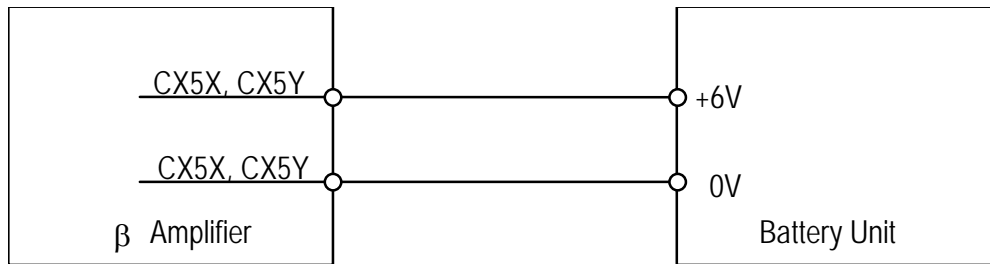

- Wire: Nominal sectional area 0.32mm² (24 AWG) or less

Connector	GE Intelligent Platforms Part No.	Manufacturer
Servo Amplifier (CX5X)	ZA06B-6093-K303	Japan Aviation Electronics Industry (Housing: IL-L2S-S3L-B(N); Contact: IL-C2-1-00001)

K10—Emergency Stop/Power Enable Cable ($\beta 0.5/3000$, $\beta 2/3000$, $\beta 3/3000$, $\beta 6/2000$, $\alpha C12/2000$)

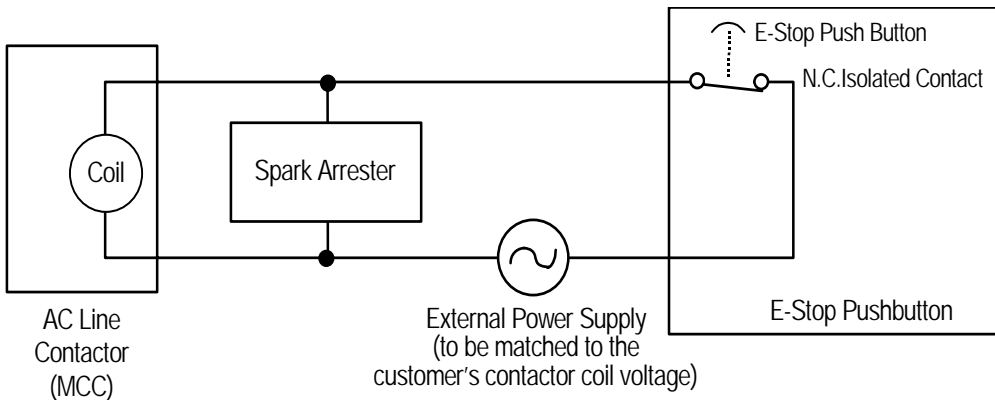

- Cable Specification: Heavy-duty vinyl power cord, 2-conductor 0.5mm² (20 AWG)
- Spark Arrester: To protect internal contacts, always use a spark arrester appropriate for the contactor you select.

K12—24 VDC Amplifier Power Cable ($\beta 0.5/3000$, $\beta 2/3000$, $\beta 3/3000$, $\beta 6/2000$, $\alpha C12/2000$)

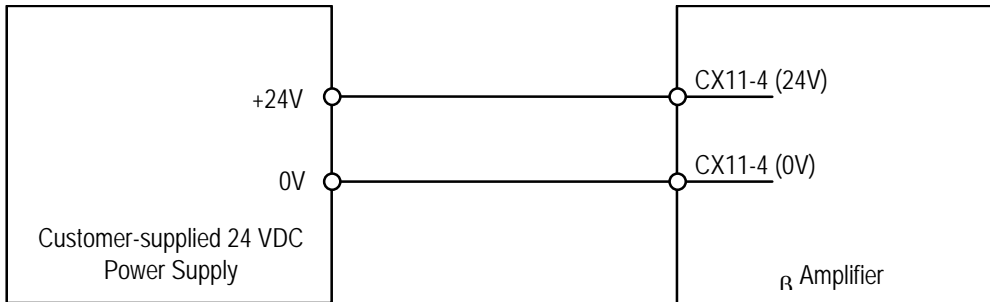

- Wire: Nominal sectional area 0.5mm² (20 AWG)

Connector	GE Intelligent Platforms Part No.	Manufacturer
DC Power Supply	N/A	N/A
Servo Amplifier CX11-4	Part of Kit ZA06B-6093-K301 (AMP version G or lower) ZA06B-6093-K305 (AMP version H or higher)	Nihon AMP (Housing: 175362-1; Contact: 1-175217-2)

K13—24 VDC Amplifier Power Daisy Chain Cable ($\beta 0.5/3000$, $\beta 2/3000$, $\beta 3/3000$, $\beta 6/2000$, $\alpha C12/2000$)

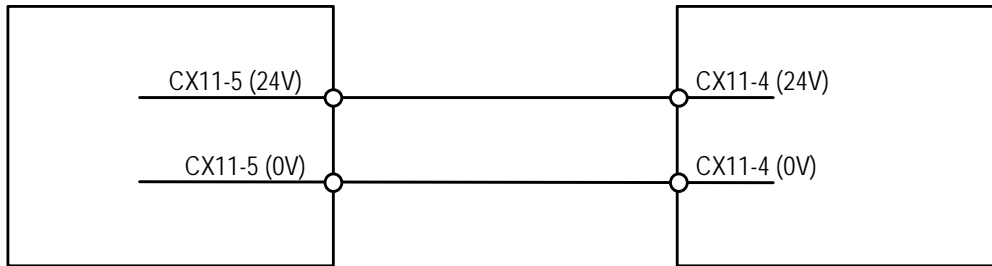

- Wire: Nominal sectional area 0.5mm² (20 AWG)

Connector	GE Intelligent Platforms Part No.	Manufacturer
DC Power Supply	N/A	N/A
Servo Amplifier CX11-5	Part of Kit ZA06B-6093-K301 (AMP version G or lower) ZA06B-6093-K305 (AMP version H or higher)	Nihon AMP (Housing: 175362-1; Contact: 1-175217-2)

K14—Motor Brake Power Cable ($\beta 2/3000$, $\beta 3/3000$, $\beta 6/2000$, $\alpha C12/2000$)

($\beta 0.5/3000$ brake wiring is include in power cable K4)

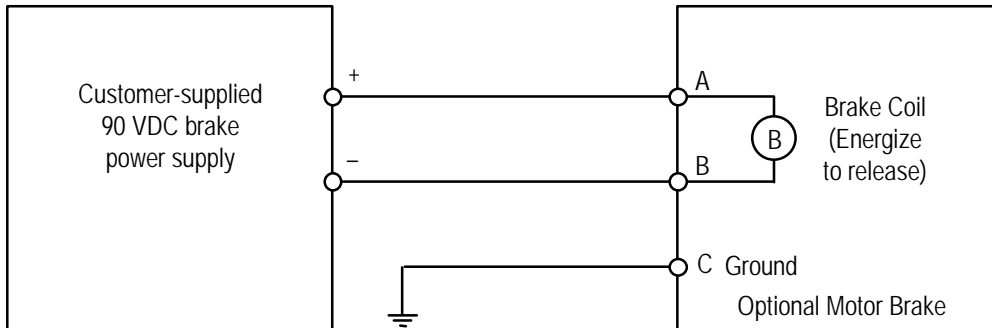

- Prefinished 14m Cable, Part number: Z44C742238-004 (severe duty)
- Wire: 300V, 3-conductor, 20 AWG (0.5mm²), finestrand, 80 °C, polyurethane (PUR) jacket

Connector	GE Intelligent Platforms Part No.	Manufacturer
Motor Brake	Customer-made cable: Z44A730464-G26 GE Intelligent Platforms cable: Z44A739012-G08	DDK CE Series (CE02-6A10SL-3CS) with Raychem Boot (222A-32-25142) 

15.4 β Series Amplifier Protection and Alarm Functions

The Servo Amplifier Unit can detect error conditions and provide alarm information.

The LEDs on the front of the amplifier provide a visual cue to the status of the system by indicating, for example, when the motor and amplifier are ready to function. The ALM LED is turned ON when an alarm condition is detected. When an alarm is detected, power is dropped and the motor is stopped by dynamic braking action. Alarm information is displayed as diagnostic data in the GE Intelligent Platforms controller. Table II-23 details the alarm conditions the β Series Servo Amplifier System can detect.

Table II-23. β Series Servo Amplifier Alarm System

<i>Alarm Condition</i>	<i>Description</i>
Over-voltage	Issued when the DC voltage in the main circuit power supply is abnormally high.
DC link under-voltage	Issued when the DC voltage in the main circuit power supply is abnormally low or when the circuit breaker has tripped.
Regenerative overheat	Issued when the average regenerative discharge energy is excessively high, such as when acceleration/deceleration is performed too frequently.
Overheat	Issued when the temperature inside the amplifier becomes so high that the thermostat trips.
Fan failure	Issued when the fan unit built into the amplifier fails.
Over-current	Issued when an abnormally high current is detected in the main circuit.

Part III:
 β_i and β_{HVi}
Series Servo
Systems

Section 16: β i and β HVi Series Servos Overview

16.1 β i and β HVi Series Servo Systems

β is Series servomotors are high performance, low inertia servomotors with built-in serial encoders. All β is Series servomotors are available with an optional 24VDC holding brake. Each β is Series servomotor must be used with the designated amplifier and a DSM324i motion controller.

Table III-1 provides a summary of β is Series servo motors. See Section 18: for more detailed motor specifications.

Table III-1. β is Series Servo Systems (230 VAC Main Power)

Motor	Rated Torque	Encoder	Required Amplifier	Motor Catalog #
β 0.4/5000 <i>is</i>	0.4 Nm (3.5 lbf-in) continuous stall torque; 5000 RPM	β 64ia (64K)	β SVM1-20i ZA06B-6130-H002	Motor Only: ZA06B-0114-B203 Motor w/ Brake: ZA06B-0114-B503
β 0.5/6000 <i>is</i>	0.65 Nm (5.8 lbf-in) continuous stall torque; 6000 RPM	β 64ia (64K)	β SVM1-20i ZA06B-6130-H002	Motor Only: ZA06B-0115-B203 Motor w/ Brake: ZA06B-0115-B503
β 1/6000 <i>is</i>	1.2 Nm (10.6 lbf-in) continuous stall torque; 6000 RPM	β 64ia (64K)	β SVM1-20i ZA06B-6130-H002	Motor Only: ZA06B-0116-B203 Motor w/ Brake: ZA06B-0116-B503
β 2/4000 <i>is</i>	2 Nm (17.7 lbf-in) continuous stall torque; 4000 RPM	β 128ia (128K)	β SVM1-20i ZA06B-6130-H002	Motor Only: ZA06B-0061-B203 Motor w/ Brake: ZA06B-0061-B503
β 4/4000 <i>is</i>	3.5 Nm (31.0 lbf-in) continuous stall torque; 4000 RPM	β 128ia (128K)	β SVM1-20i * ZA06B-6130-H002	Motor Only: ZA06B-0063-B203 Motor w/ Brake: ZA06B-0063-B503
β 8/3000 <i>is</i>	7 Nm (62.0 lbf-in) continuous stall torque; 3000 RPM	β 128ia (128K)	β SVM1-20i ** ZA06B-6130-H002	Motor Only: ZA06B-0075-B203 Motor w/ Brake: ZA06B-0075-B503
β 12/3000 <i>is</i>	11 Nm (97.4 lbf-in) continuous stall torque; 3000 RPM	β 128ia (128K)	β SVM1-40i ZA06B-6130-H003	Motor Only: ZA06B-0078-B203 Motor w/ Brake: ZA06B-0078-B503
β 22/2000 <i>is</i>	20 Nm (177.0 lbf-in) continuous stall torque; 2000 RPM	β 128ia (128K)	β SVM1-40i ZA06B-6130-H003	Motor Only: ZA06B-0085-B203 Motor w/ Brake: ZA06B-0085-B503

* Requires Fan Kit (ZA06B-6134-K003) for single-phase mains power.

** Fan Kit (ZA06B-6134-K003) always required.

Servo Products Specification Guide

Table III-2. β HVi Series Servo Systems (460 VAC Main Power)

<i>Motor</i>	<i>Rated Torque</i>	<i>Encoder</i>	<i>Required Amplifier</i>	<i>Motor Catalog #</i>
β 2/4000HVi	2 Nm (17.7 lbf-in) continuous stall torque; 5000 RPM	β 128ia (128K)	β SVM1-10HVi ZA06B-6131-H001	Motor Only: ZA06B-0062-B203 Motor w/ Brake: ZA06B-0062-B503
β 4/4000HVi	3.5 Nm (31 lbf-in) continuous stall torque; 5000 RPM	β 128ia (128K)	β SVM1-10HVi ZA06B-6131-H001	Motor Only: ZA06B-0064-B203 Motor w/ Brake: ZA06B-0064-B503
β 8/3000HVi	7 Nm (62 lbf-in) continuous stall torque; 3000 RPM	β 128ia (128K)	β SVM1-10HVi ZA06B-6131-H001	Motor Only: ZA06B-0076-B203 Motor w/ Brake: ZA06B-0076-B503
β 12/3000HVi	11 Nm (97.4 lbf-in) continuous stall torque; 3000 RPM	β 128ia (128K)	β SVM1-20HVi ZA06B-6131-H002	Motor Only: ZA06B-0079-B203 Motor w/ Brake: ZA06B-0079-B503
β 22/2000HVi	20 Nm (177.0 lbf-in) continuous stall torque; 2000 RPM	β 128ia (128K)	β SVM1-20HVi ZA06B-6131-H002	Motor Only: ZA06B-0086-B203 Motor w/ Brake: ZA06B-0086-B503

16.2 β i Series Servo Amplifier Packages

The following table shows which amplifier model is included in each β i Series servo package:

Table III-3. β i and β HVi Series Servo Amplifiers and Packages

Motor	Amplifier Model	Amplifier Catalog #	Amplifier Package Catalog #
β 0.4/5000is	β SVM1-20i	ZA06B-6130-H002	IC800BIK020
β 0.5/6000is	β SVM1-20i	ZA06B-6130-H002	IC800BIK020
β 1/6000is	β SVM1-20i	ZA06B-6130-H002	IC800BIK020
β 2/4000is	β SVM1-20i	ZA06B-6130-H002	IC800BIK020
β 4/4000is	β SVM1-20i	ZA06B-6130-H002	IC800BIK020
β 8/3000is	β SVM1-20i	ZA06B-6130-H002	IC800BIK020
β 12/3000is	β SVM1-40i	ZA06B-6130-H003	IC800BIK040
β 22/2000is	β SVM1-40i	ZA06B-6130-H003	IC800BIK040
β 2/4000HVis	β SVM1-10HVi	ZA06B-6131-H001	IC800BIHV010
β 4/4000HVis	β SVM1-10HVi	ZA06B-6131-H001	IC800BIHV010
β 8/3000HVis	β SVM1-10HVi	ZA06B-6131-H001	IC800BIHV010
β 12/3000HVis	β SVM1-20HVi	ZA06B-6131-H002	IC800BIHV020
β 22/2000HVis	β SVM1-20HVi	ZA06B-6131-H002	IC800BIHV020

As a convenience, amplifiers can also be ordered as a package containing all of the components required to operate the amplifier in a servo system, as detailed in the following table:

Table III-4. β i Series Servo Amplifier Packages

Description	Package Contents*	Catalog #
20 Amp β i-Series Amplifier Package	<ul style="list-style-type: none"> ■ βSVM1-20i 20A amplifier (ZA06B-6130-H002) – Qty 1 ■ Spare 24 VDC Fuse (ZA06B-6073-K250) – Qty 1 ■ 20 Watt Discharge Resistor (ZA06B-6130-H401) – Qty 1 ■ CZ7 Power Connector Kit (ZA06B-6130-K200) – Qty1 ■ CXA19 24 VDC Connector Kit (ZA06B-6130-K201) – Qty 2 ■ CXA20 Discharge Thermostat Connector Kit (ZA06B-6130-K202) – Qty 1 ■ CX29 MCC Connector Kit (ZA06B-6130-K203) – Qty 1 ■ CX30 E-stop Connector Kit (ZA06B-6130-K204) – Qty 1 	IC800BIK020
40 Amp β i-Series Amplifier Package	<ul style="list-style-type: none"> ■ βSVM1-40i 40A amplifier (ZA06B-6130-H003) – Qty 1 ■ Spare 24 VDC Fuse (ZA06B-6073-K250) – Qty 1 ■ 20 Watt Discharge Resistor (ZA06B-6130-H401) – Qty 1 ■ CZ4 Power Connector Kit (ZA06B-6110-K200#XXS) – Qty1 ■ CZ5 Motor Power Connector Kit (ZA06B-6110-K202#YYs) – Qty 1 ■ CZ6 Discharge Resistor Connector Kit (ZA06B-6110-K201#XYM) – Qty 1 ■ CXA19 24 VDC Connector Kit (ZA06B-6130-K201) – Qty 2 ■ CXA20 Discharge Thermostat Connector Kit (ZA06B-6130-K202) – Qty 1 ■ CX29 MCC Connector Kit (ZA06B-6130-K203) – Qty 1 ■ CX30 E-stop Connector Kit (ZA06B-6130-K204) – Qty 1 	IC800BIK040

Servo Products Specification Guide

<i>Description</i>	<i>Package Contents*</i>	<i>Catalog #</i>
10 Amp β HVi Series (High Voltage) Amplifier Package	<ul style="list-style-type: none"> ■ SVM1-10HVi Amplifier (ZZA06B-6131-H001) – Qty 1 ■ Spare 24 VDC Fuse (ZA06B-6073-K250) – Qty 1 ■ CZ4 Power Connector Kit (ZA06B-6110-K200#XXS) – Qty 1 ■ CZ5 Motor Power Connector Kit (ZA06B-6110-K202#YYS) – Qty 1 ■ CZ6 Regenerative Discharge Resistor Connector Kit (ZA06B-6110-K201#XYM) – Qty 1 ■ CXA19 24 VDC Connector Kit (ZA06B-6130-K201) – Qty 2 ■ CXA20 Regenerative Resistor Thermostat Connector Kit (ZA06B-6130-K202) – Qty 1 ■ CX29 MCC Connector Kit (ZA06B-6130-K203) – Qty 1 ■ CX30 Estop Connector Kit (ZA06B-6130-K204) – Qty 1 	IC800BIHV010
20 Amp β HVi Series (High Voltage) Amplifier Package	<ul style="list-style-type: none"> ■ SVM1-20HVi Amplifier (ZA06B-6131-H002) – Qty 1 ■ Spare 24 VDC Fuse (ZA06B-6073-K250) – Qty 1 ■ CZ4 Power Connector Kit (ZA06B-6110-K200#XXS) – Qty 1 ■ CZ5 Motor Power Connector Kit (ZA06B-6110-K202#YYS) – Qty 1 ■ CZ6 Regenerative Discharge Resistor Connector Kit (ZA06B-6110-K201#XYM) – Qty 1 ■ CXA19 24 VDC Connector Kit (ZA06B-6130-K201) – Qty 2 ■ CXA20 Regenerative Resistor Thermostat Connector Kit (ZA06B-6130-K202) – Qty 1 ■ CX29 MCC Connector Kit (ZA06B-6130-K203) – Qty 1 ■ CX30 Estop Connector Kit (ZA06B-6130-K204) – Qty 1 	IC800BIHV020
40 Amp β HVi Series (High Voltage) Amplifier Package	<ul style="list-style-type: none"> ■ SVM1-40HVi Amplifier (ZA06B-6131-H003) – Qty 1 ■ Spare 24 VDC Fuse (ZA06B-6073-K250) – Qty 1 ■ CZ4 Power Connector Kit (ZA06B-6110-K200#XXS) – Qty 1 ■ CZ5 Motor Power Connector Kit (ZA06B-6110-K202#YYS) – Qty 1 ■ CZ6 Regenerative Discharge Resistor Connector Kit (ZA06B-6110-K201#XYM) – Qty 1 ■ 24VDC Connector Kit (ZA06B-6130-K201 CXA19) – Qty 1 ■ CXA20 Regenerative Resistor Thermostat Connector Kit (ZA06B-6130-K202) – Qty 1 ■ CX29 MCC Connector Kit (ZA06B-6130-K203) – Qty 1 ■ CX30 Estop Connector Kit (ZA06B-6130-K204) – Qty 1 	IC800BIHV040

* Amplifier package components can also be ordered separately.

Section 17: β i Servo System Options

Designing a servo control system requires that you understand how the electrical and mechanical aspects of your system interact. The table below will help you select which servo options your system requires.

Table 3-5. β i Servo System Options

Servo Option	Consider Selecting When	Catalog #	Section #
Motor Holding Brake	The system design includes an axis that must hold its position when power is removed	Refer to Table 5HIII-1	18.4
Absolute Encoder Battery Backup Kit	You want to avoid having to re-reference the position when power is restored to the control	IC800BBK021 (1-axis) IC800ABK001 (4-axis)	19.5
AC Line Filters	200—240 VAC is already available to the control cabinet and no isolation transformer is used	5.4 kW, 3-phase: ZA81L-0001-0083#3C 10.5 kW, 3-phase: ZA81L-0001-0101#C	23.2
Pre-finished Cables	The cable lengths available are appropriate for your application	Refer to “Cable Connections” Table	24
Discharge Resistor	See “Discharging Regenerative Energy;” The 20 Watt discharge resistor is included in all 20 amp β i Series Amplifier Packages. The 40 amp amplifier includes an integral discharge resistor. The external 100 W discharge resistor offers additional capacity when required.	ZA06B-6130-H401 ZA06B-6130-H402 ZA06B-6089-H500 ZA06B-6089-H713	23.7
Ground Clamp	CE Installation or high electrical noise environment.	ZA99L-0035-0001, Clamp Z44B295864-001, Bar	22.3
Absolute Encoder Battery Backup Connector	You want to daisy chain multiple amplifiers together to share the multi-axis battery pack IC800ABK001.	ZA06B-6093-K303	NA

Table III-6. β HVi Servo System Options

Servo Option	Consider Selecting When	Catalog #	Section #
Motor Holding Brake	The system design includes an axis that must hold its position when power is removed	Refer to Table 5HIII-1	18.4
Absolute Encoder Battery Backup Kit	You would like to avoid having to re-reference the position when power is restored to the control	IC800BBK021 (1-axis) IC800ABK001 (4-axis)	19.5
AC Line Filters	400—480 VAC is already available to the control cabinet and no isolation transformer is used	5.4 kW, 3-phase: ZA81L-0001-0168 10.5 kW, 3-phase: ZA81L-0001-0169	23.2
Pre-finished Cables	The cable lengths available are appropriate for your application	Refer to “Cable Connections” Table	24
Ground Clamp	CE Installation or high electrical noise environment.	ZA99L-0035-0001, Clamp Z44B295864-001, Bar	22.3
Absolute Encoder Battery Backup Connector	You want to daisy chain multiple amplifiers together to share the multi-axis battery pack IC800ABK001.	ZA06B-6093-K303	NA

Section 18: Servo Motors

18.1 Servo Motor Specifications

The βi Series Servo system consists of a servomotor and its corresponding amplifier and cables. GE Intelligent Platforms offers several βi s series servo motors, which are identified below.

Table 3-7. Specifications of βi s Servo Motors

	Unit	$\beta 0.4/5000is$	$\beta 0.5/6000is$	$\beta 1/6000is$	$\beta 2/4000is$	$\beta 4/4000is$	$\beta 8/3000is$	$\beta 12/3000is$	$\beta 22/2000is$
Rated torque at stall *	Nm	0.4	0.65	1.2	2.0	3.5	7.0	11.0	20.0
	lbf-in	3.5	5.8	10.6	17.7	31.0	62.0	97.4	177.0
Stall Current *	A (rms)	3.6	2.9	2.7	3.3	4.7	6.0	10.2	11.3
Rated Output *	kW	0.13	0.2	0.4	0.5	0.75	1.2	1.8	2.5
	HP	0.17	0.27	0.54	0.67	1.0	1.6	2.4	3.4
Rated Speed	RPM	4000	6000	6000	4000	3000	2000	2000	2000
Max. Speed	RPM	5000	6000	6000	4000	4000	3000	3000	2000
Peak Torque *	Nm	1.0	2.5	5.0	7.0	10.0	15.0	27.0	45.0
	lbf-in	8.9	22.1	44.3	62.0	88.5	132.8	239.0	398.3
Rotor Inertia	Kgm ²	0.00001	0.000018	0.000034	0.000291	0.000515	0.00117	0.00228	0.00527
	lbf-ft-s ² * (10 ⁻⁶)	7.3756215	13.276118	25.07711	214.6305	379.8445	862.9477	1681.6417	3886.9525
Rotor Inertia (with brake)	Kgm ²	0.000019	0.000027	0.000043	0.000311	0.000535	0.00124	0.00235	0.00587
	lbf-ft-s ² * (10 ⁻⁶)	14.013681	19.914178	31.715172	229.38182 9	394.59575 0	914.5771	1733.27105	4329.48982
Torque Constant *	Nm/A	0.112	0.223	0.45	0.62	0.75	1.16	1.08	1.77
	Lbf-in/A								
Back EMF Const. (1 phase) *	Vsec/rad (rms)	0.038	0.074	0.14	0.21	0.25	0.39	0.36	0.59
Resistance (1 phase) *	ohm	0.55	0.85	1.5	1.6	0.94	1.00	0.39	0.44
Mechanical Time Constant	sec	0.001	0.0009	0.0007	0.004	0.003	0.003	0.002	0.002
Thermal time Constant	min	8	10	15	15	20	20	25	30
Static friction	Nm	0.04	0.04	0.04	0.1	0.2	0.3	0.4	0.8
Weight	kg	0.8	1.0	1.5	2.8	4.3	7.4	11.9	17.0
	lb	1.8	2.2	3.3	6.2	9.5	16.3	26.2	37.4
Weight (with brake)	kg	1.2	1.4	1.9	3.8	5.3	9.6	14.1	23.0
	lb	2.6	3.1	4.2	8.4	11.7	21.1	31.0	50.6
Max Current	A (peak)	20	20	20	20	20	20	40	40

*These values are standard values at 20°C with a tolerance of $\pm 10\%$. The speed-torque characteristics vary, depending on the type of software, parameter setting, and input voltage of the digital servo amplifiers. (The above figures show average values.) These values may be changed without prior notice.

Servo Products Specification Guide

Table 3-8. Specifications of β HV's Servo Motors

	Unit	β 2/4000HVis	β 4/4000HVis	β 8/3000HVis	β 12/3000HVis	β 22/2000HVis
Rated torque at stall *	Nm	2	3.5	7	11	20
	lbf-in	17.7	31	62	97.4	177.02
Stall Current *	A (rms)	1.6	2.3	3	5.1	5.6
Rated Output *	kW	0.5	0.75	1.2	1.8	2.5
	HP	0.67	1	1.6	2.4	3.4
Rated Speed	RPM	4000	3000	2000	2000	2000
No Load Speed	RPM	4000	4000	3000	3000	2000
Encoder Resolution	Counts/Rev	131,072	131,072	131,072	131,072	131,072
Flange Size	mm	90	90	130	130	174
Peak Torque *	Nm	7	10	15	27	45
	lbf-in	62	88.5	132.8	2.9	398.3
Rotor Inertia	Kgm ²	2.91	5.15	11.7	22.8	52.7
	lbf-ft-s ² *(10 ⁻⁶)	25.76	45.58	103.55	201.80	466.43
Rotor Inertia (with brake)	Kgm ²	3.11	5.35	12.4	23.5	58.7
	lbf-ft-s ² *(10 ⁻⁶)	25.73	47.35	109.75	208.0	519.4
Torque Constant *	Nm/A	1.23	1.5	2.32	2.16	3.5
	Lbf-in/A	10.89	13.28	20.53	19.12	30.98
Back EMF Const. (1 phase) *	Vsec/rad (rms)	43	53	81	76	120
Resistance (1 phase) *	ohm	6.6	4	3.9	1.6	1.8
Mechanical Time Constant	sec	4	3	3	2	2
Thermal time Constant	min	15	20	20	25	30
Static friction	Nm	0.1	0.2	0.3	0.4	0.8
Weight	kg	2.8	4.3	7.4	11.9	17
	lb	6.16	9.46	16.28	26.18	37.4
Weight (with brake)	kg	3.8	5.3	9.6	14.1	23.0
	lb	8.4	11.7	21.1	31.0	50.6
Axial Load Rating	kg	8	8	20	20	60
	lb	17.6	17.6	44	44	132
Radial Load Rating	kg	25	25	70	70	200
	lb	55	55	154	154	440
Max Current	A (peak)	10	10	10	20	20

*These values are standard values at 20°C with a tolerance of $\pm 10\%$. The speed-torque characteristics vary, depending on the type of software, parameter setting, and input voltage of the digital servo amplifiers. (The above figures show average values.) These values may be changed without prior notice.

18.2 β is and β HVi Series Motor Speed–Torque Curves

The curves shown in the following figure illustrate the relationship between the speed of the motor and the output torque. The motor can operate continuously at any combination of speed and torque within the prescribed continuous operating zone. The limit of the continuous operating zone is determined with the motor’s ambient temperature at 20°C and its drive current as pure sine wave. The curves reflect peak torque limits based on maximum current of the servo amplifier unit.

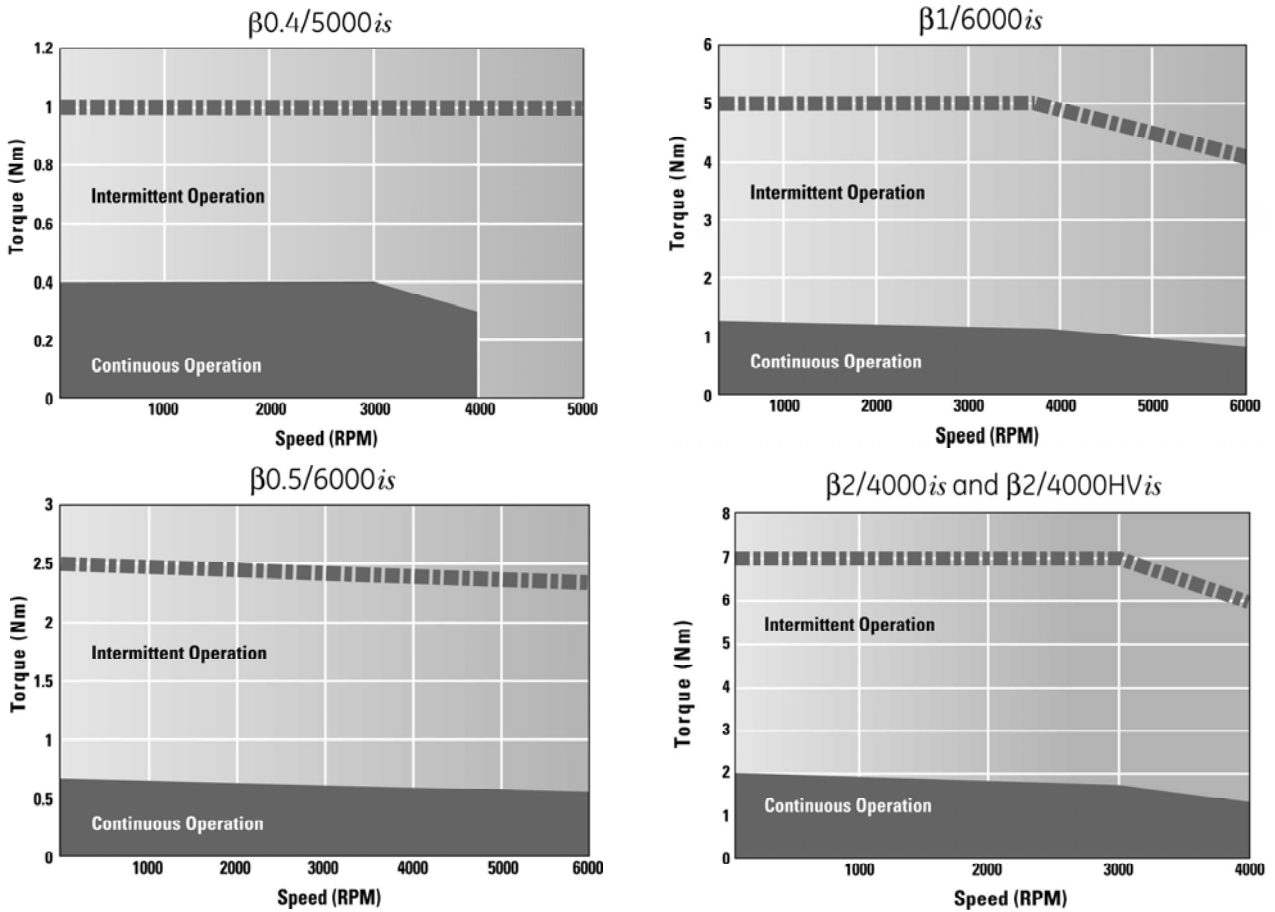

Figure III-1. β is and β HVi Series Servo Motor Speed-Torque Curves ($\beta 0.4/6000$, $\beta 0.5/6000$, $\beta 1/6000$, $\beta 2/4000$)

Servo Products Specification Guide

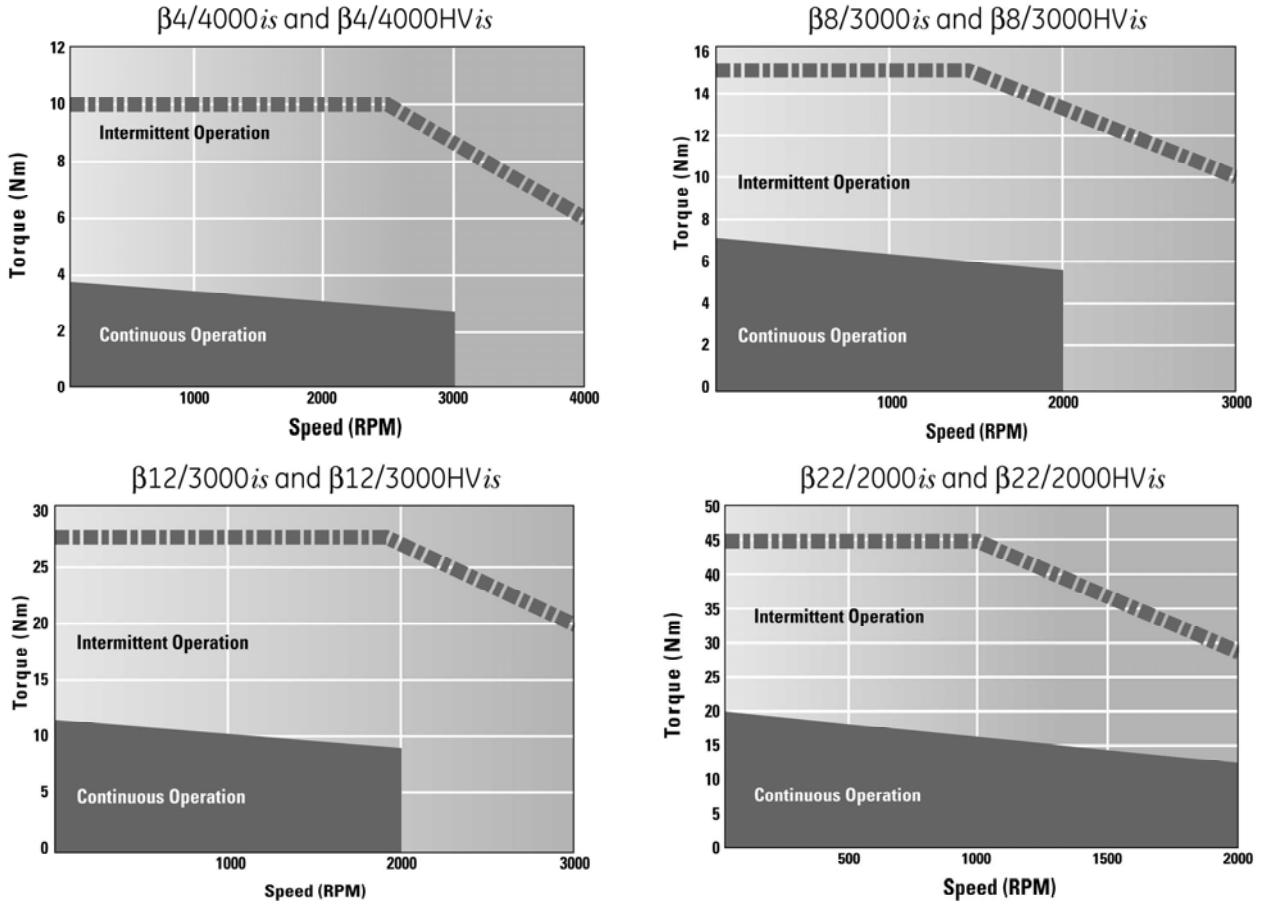
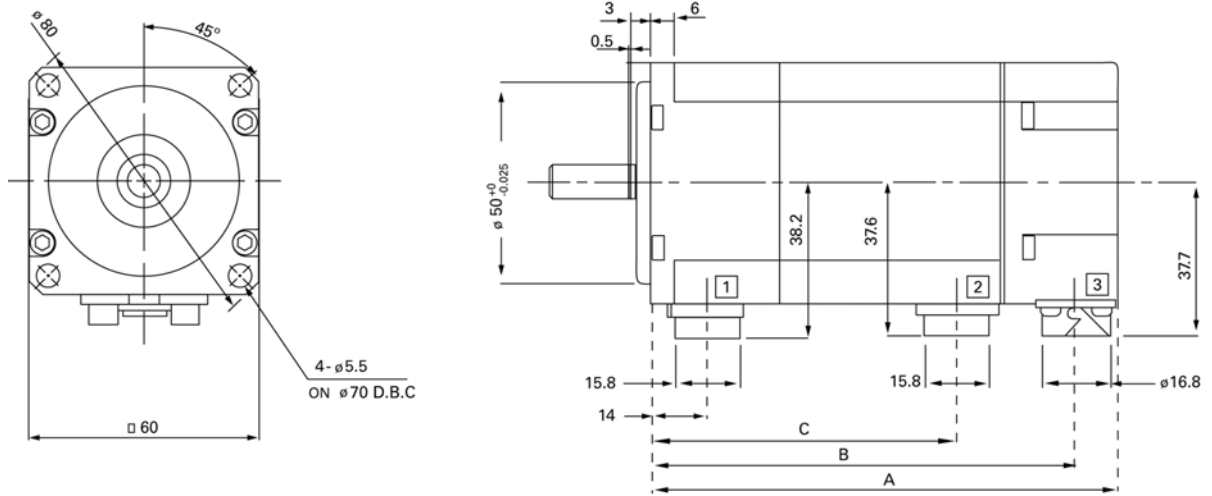
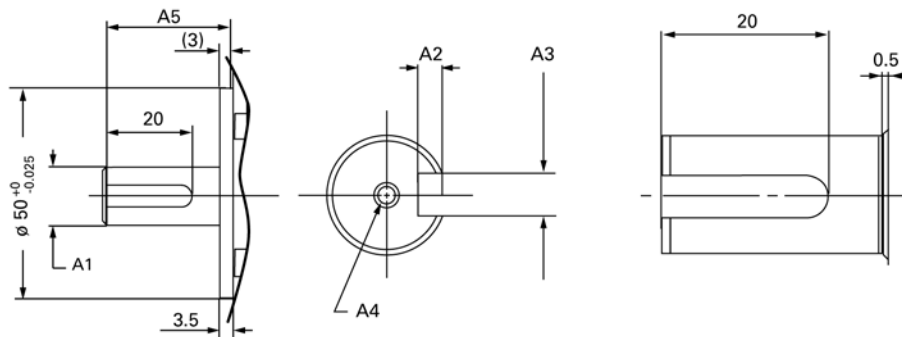

Figure III-2. βis and $\beta HV is$ Series Servo Motor Speed-Torque Curves ($\beta 4/4000$, $\beta 8/3000$, $\beta 12/3000$, $\beta 22/2000$)

18.3 Motor Outline Drawings



Motor



Shaft Detail

Dimensions shown mm

Dimension	$\beta 0.4/5000is$	$\beta 0.5/6000is$	$\beta 1/6000is$
A	75	89.5	118.5
A with brake	101.5	116	145
A1	$\phi 9^{+0.000}_{-0.009}$	$\phi 9^{+0.000}_{-0.009}$	$\phi 14^{+0.000}_{-0.011}$
A2	$1.2^{+0.0}_{-0.1}$	$1.2^{+0.0}_{-0.1}$	$2^{+0.0}_{-0.1}$
A3	$3^{+0.000}_{-0.025}$	$3^{+0.000}_{-0.025}$	$5^{+0.00}_{-0.33}$
A4	M3 Depth 6	M3 Depth 6	M4 Depth 10
A5	25	25	30
B	65	79.5	108.5
B with brake	91.5	106	135
C	34.5	49	78
C with brake	61	75.5	104.5

Connector	Description
1	Brake (optional)
2	Power
3	Encoder

Notes:

1. Shaft diameter runout = 0.02mm max
2. Flange surface runout = 0.06mm max
3. Maximum radial load for output shaft is 20kgf (44lb)

Figure III-3. $\beta 0.4is$, $\beta 0.5is$ and $\beta 1is$ Series Servo Motor Outline Drawing

Servo Products Specification Guide

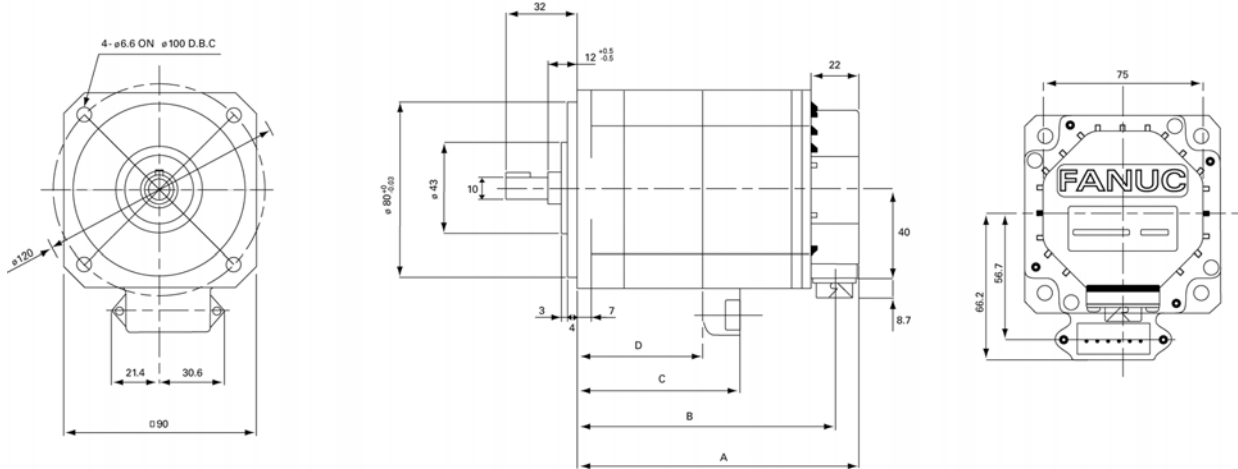

Power/Brake Connections					
1	2	3	4	5	6
U	V	W	G	B	B

Motor

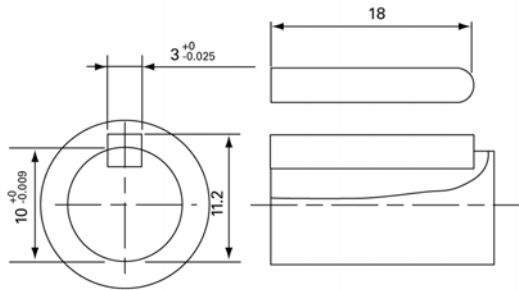

Shaft Detail

Dimensions shown mm

Dimension	$\beta 2/4000is$, $\beta 2/4000HVis$
A	130
A with brake	159
B	119
B with brake	148
C	75
C with brake	75
D	59
D with brake	59

- Notes:**
1. Shaft diameter runout = 0.02mm max
 2. Flange surface runout = 0.06mm max
 3. Maximum radial load for output shaft is 25kgf (55lb)

Figure III-4. $\beta 2is$ Series Servo Motor Outline Drawing

Servo Products Specification Guide

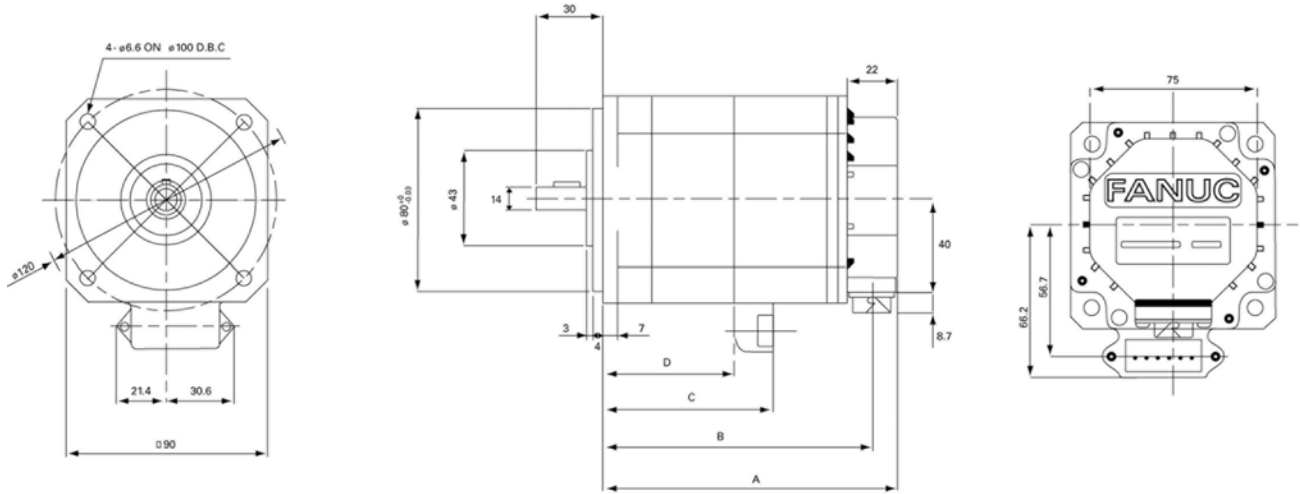

Power/Brake Connections					
1	2	3	4	5	6
U	V	W	G	B	B

Motor

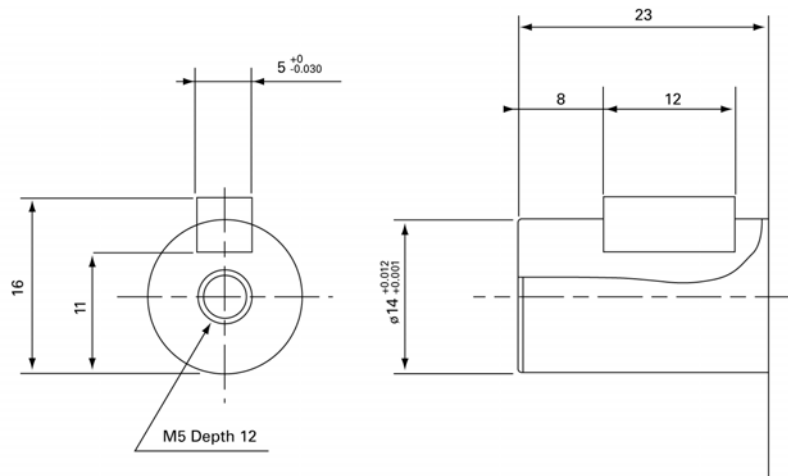

Shaft Detail

Dimensions shown mm

Dimension	$\beta 4/4000is$, $\beta 4/4000HVis$
A	166
A with brake	195
B	155
B with brake	184

Dimension	$\beta 4/4000is$, $\beta 4/4000HVis$
C	111
C with brake	111
D	95
D with brake	95

- Notes:**
1. Shaft diameter runout = 0.02mm max
 2. Flange surface runout = 0.06mm max
 3. Maximum radial load for output shaft is 25kgf (55lb)

Figure III-5. $\beta 4is$ Series Servo Motor Outline Drawing

Servo Products Specification Guide

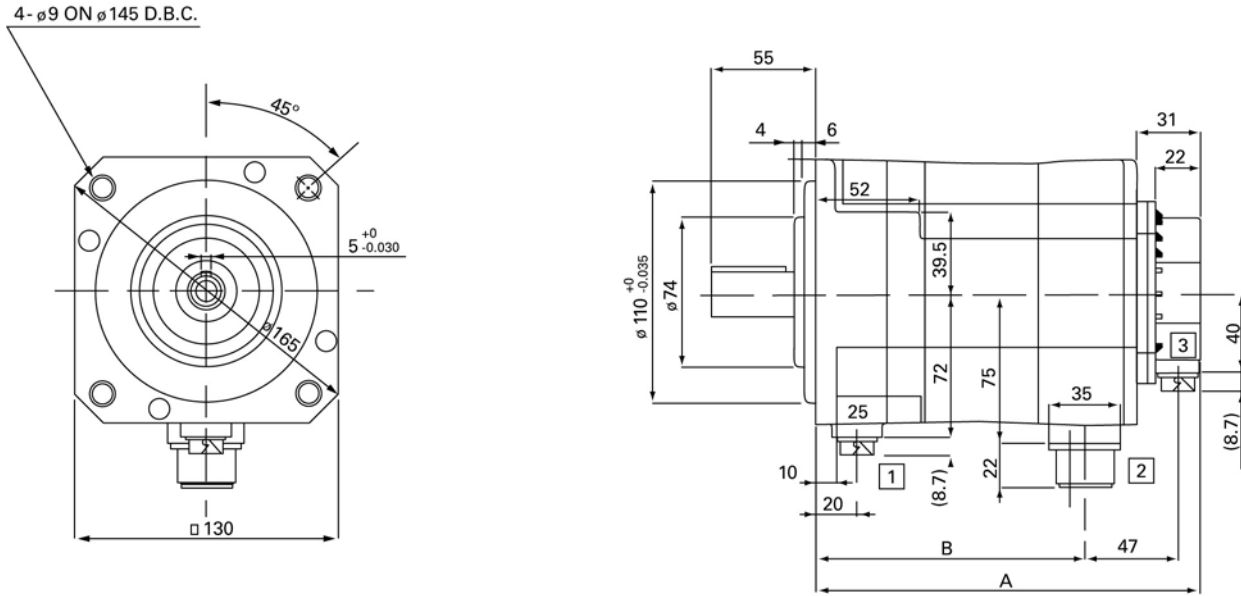

Motor

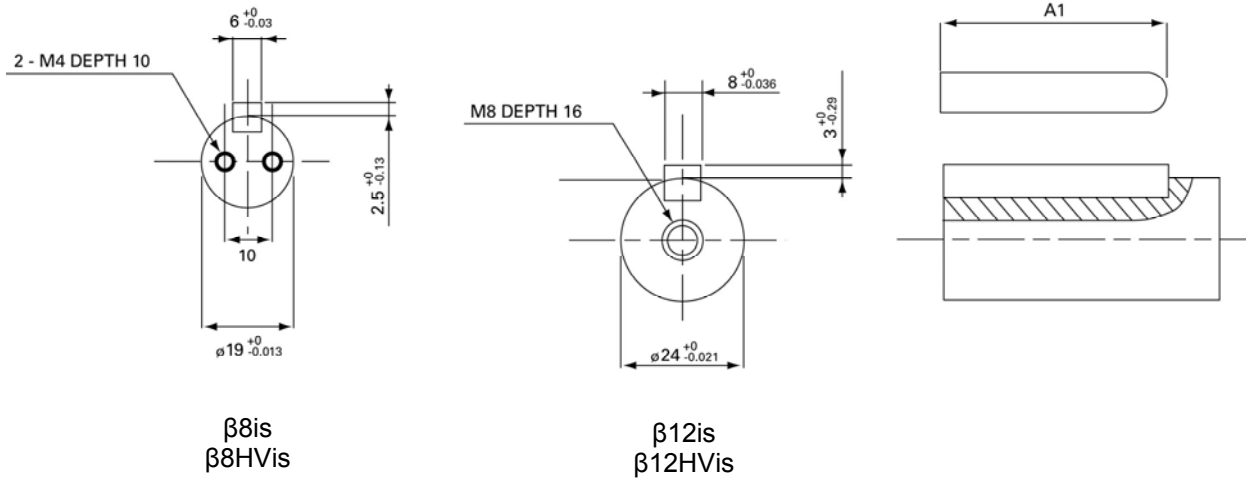

Shaft Detail

Dimensions shown mm

Dimension	$\beta 8/3000is,$ $\beta 8/3000HVis$	$\beta 12/3000is,$ $\beta 12/3000HVis$
A	166	222
A with brake	191	247
A1	36	45
B	108	164
B with brake	133	189

Connector	Description
1	Brake (optional)
2	Power
3	Encoder

Notes:

1. Shaft diameter runout = 0.02mm max
2. Flange surface runout = 0.05mm max
3. Maximum radial load for output shaft is 70kgf (154lb)

Figure III-6. $\beta 8is$ and $\beta 12is$ Series Servo Motor Outline Drawing

Servo Products Specification Guide

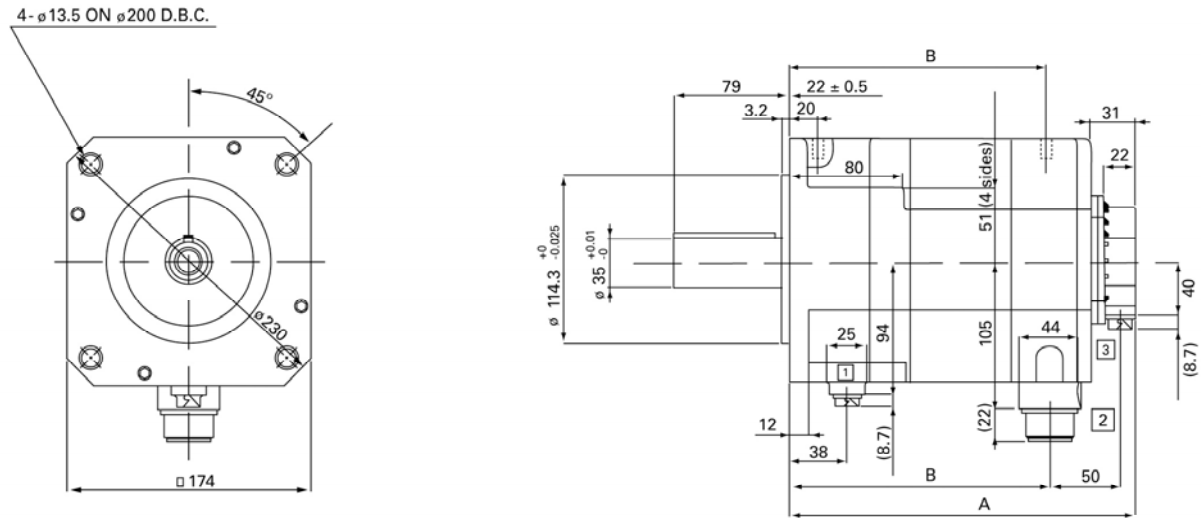

Motor

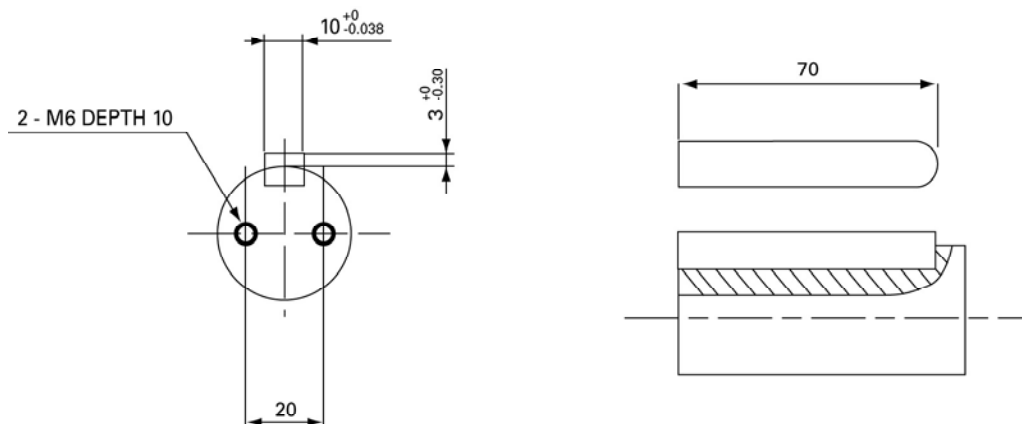

Shaft Detail

Dimension	$\beta 22/2000is$, $\beta 22/2000HVis$,
A	202
A with brake	243
B	141
B with brake	182

Dimensions shown mm

Connector	Description
1	Brake (optional)
2	Power
3	Encoder

Notes:

1. Shaft diameter runout = 0.03mm max
2. Flange surface runout = 0.06mm max
3. Maximum radial load for output shaft is 200kgf (440lb)

Figure III-7. $\beta 22is$ Series Servo Motor Outline Drawing

18.4 β is and β HVis Series Servo Motor Holding Brake

The holding brake is used to prevent movement on horizontal axes or falling along the vertical axis when the servo motor control is turned off. Brakes are spring-set and electrically released and are designed for holding stationary loads only. Using the holding brake to stop a moving axis may damage the brake or severely reduce its service life.

The specifications of the built-in brakes are listed in the following table.

Table 3-9. β is and β HVis Motor Holding Brake Specifications

<i>Motor Model</i>		<i>Unit</i>	<i>β0.4is β0.5is</i>	<i>β1is</i>	<i>β2is/β2HVis β4is/β4HVis</i>	<i>β8is/β8HVis β12is/β12HVis</i>	<i>β22is/β22HVis</i>
Brake Holding Torque		Nm	0.65	1.2	3	8	35
		lbf-in	5.8	10.6	26.6	70.8	309.8
Response Time	Release	msec	40	40	60	160	160
	Brake	msec	20	20	10	30	30
Power Supply	Voltage	VDC	24 (\pm 10%)				
	Current	A	0.5	0.5	0.9	1.1	1.2
	Power	W	12	12	22	26	29
Weight Increase		kg	0.4	0.4	1.0	2.2	6.0
Inertia Increase		kg-m ²	0.000009	0.000009	0.00002	0.00007	0.0006
		lbf-in-s ²	0.0000797	0.0000797	0.000177	0.0006195	0.000531

The values shown above are standard values at 20°C.

18.5 Brake Power Supply Circuit

The following table lists the recommended parts and their specifications to be used as components of a user-built brake circuit. Configure a brake circuit by referencing the following brake connection diagram and the recommended parts as shown below.

Table 3-10. β is Holding Brake Circuit Components

Name	Model No.	Name of Manufacturer	Specifications
Rectifier	D3SB60	Shindengen Electric Mfg. Co., Ltd.	Withstand voltage 400V min. Maximum output current: 2.3 A (with no fins)
Switch	N/A	N/A	Rated load capacity (resistance load) 250VAC 10A / 30VDC 10A or more
Spark Killer	XEB0471	Okaya Electric Ind. Co., Ltd.	47 ohm/0.1 μ F Withstand voltage 400V min
Surge Absorber	ERZV10D820	Matsushita Electric Industrial Co., Ltd.	Varistor voltage 82V Max allowable voltage 50 VAC

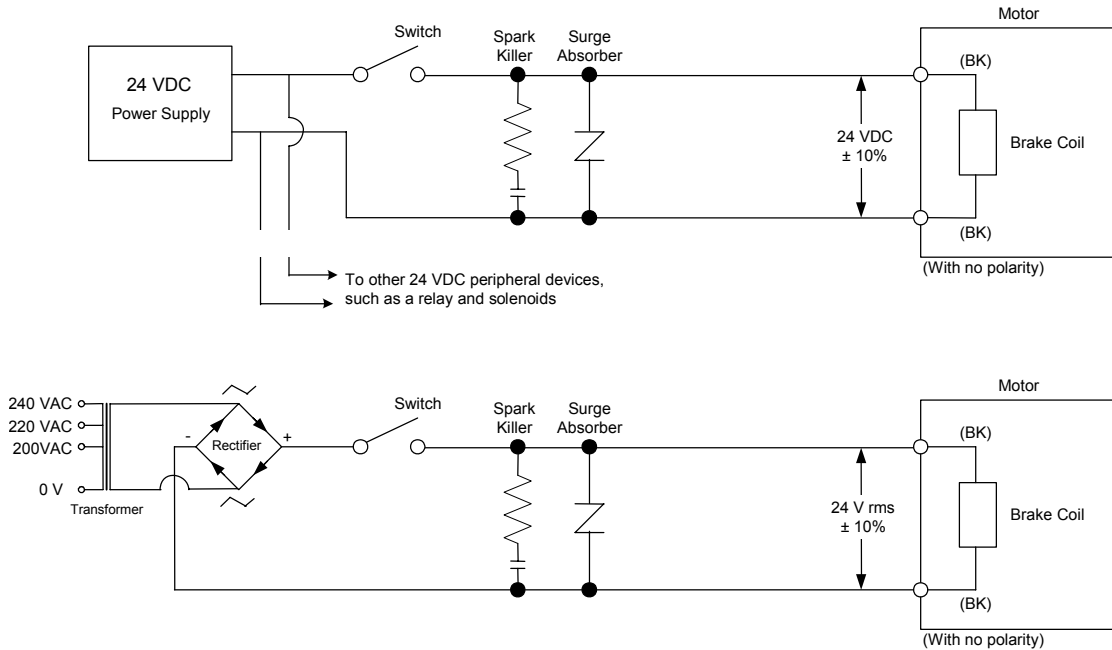

Figure III-8. Connecting Motor Holding Brake Control and Power Circuit

Caution

To prevent amplifier malfunction or damage do not use the same 24V power supply for the amplifier control logic circuitry as the power supply for the brake.

Servo Products Specification Guide

Option 1: Use a commercial 24 VDC power supply as the power supply for the β/s series servo motor brake. To prevent amplifier malfunction or damage do not use the same 24V power supply for the amplifier control logic circuitry as the power supply for the brake. The power supply for a relay, solenoid, or another peripheral device can be used for the brake. Be careful of the power capacity and changes in voltage due to load changes.

Option 2: Alternately you may build a power supply for the brake circuit (equivalent to 24 Vrms) produced by full-wave rectification after transforming commercial power (50 Hz/60 Hz). For user built full-wave rectification, transform the secondary voltage into approximately 29 VAC by taking voltage drop in the rectifier or cable into account. Check to make sure the power capacity and power voltage fluctuations of the voltage applied to the brake falls within 24 Vrms $\pm 10\%$.

If the brake switching contact is installed on the DC side (at the position shown in the figure), the life of the contact is generally shortened due to the surge voltage when the brake is turned off. Provide an adequate contact capacity and always use a surge absorber and spark killer for protecting the contact. Installing the switching contact on the DC side of the power provides the fastest brake operation time.

18.6 Motor Connections

Connections

Serial Encoder Connections

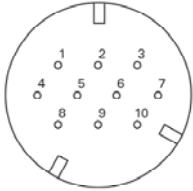

All β is and β HVis Motors

Description	Motor Connector	Amplifier JF1 Connector
N/C	2	1
N/C	1	2
RD	6	5
$\overline{\text{RD}}$	5	6
+5 VDC	8,9	9,20
0 VDC	7,10	12,14
+6 VA (battery)	4	7
Frame Ground	3	16
Cable Shield	3	16
Mating Connector: ZA06B-6114-K204#E (90 degree) ZA06B-6114-K204#S (straight)		

Power and Brake Connections

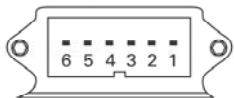

β 2is & β 4is Motor Power/Brake

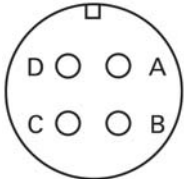

β 8is, β 12is & β 22is Motor Power

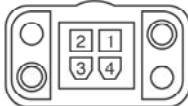

β 0.4is, β 0.5is & β 1is Motor Power



β 8is, β 12is & β 22is Brake

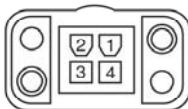

β 0.4is, β 0.5is & β 1is Brake

Description	β 0.4is, β 0.5is, β 1is Motor Connector	β 2is/ β 2HVis β 4HVis Motor Connector	β 8is/ β 8HVis β 12is/ β 12HVis β 22is/ β 22HVis Motor Connector	β i and β HVi Series Amplifier Connector
Phase U	2	1	A	U
Phase V	2	2	B	V
Phase W	3	3	C	W
Earth (case)	4	4	D	PE
Brake VDC	n/a	5	n/a	n/a
Brake VDC	n/a	6	n/a	n/a
Mating Connector: ZA06B-6114-K220#E (90 degree) (β 2is, β 4is, β 2HVis, β 4HVis) ZA06B-6114-K220#S (straight) (β 2is, β 4is, β 2HVis, β 4HVis) Z44A730464-G18 (β 8is, β 12is, β 8HVis, β 12HVis) ZA06B-6114-K230#E (β 0.4is, β 0.5is, β 1is) Z44A730464-G20 (β 22is, β 22HVis)				

Description	β 0.4is, β 0.5is & β 1is Motor Connector	β 8is/ β 8HVis β 12is/ β 12HVis β 22is/ β 22HVis Motor Connector
Brake VDC	1	1
Brake VDC	2	2
Earth (case)	4	4
Mating Connector: ZA06B-6114-K213#E (90 degree) (β 8is, β 12is, β 22is, β 8HVis, β 12HVis, β 22HVis) ZA06B-6114-K213#S (straight) (β 8is, β 12is, β 22is, β 8HVis, β 12HVis, β 22HVis) ZA06B-6114-K232#E (β 0.4is, β 0.5is, β 1is)		

Brake power connections are not polarized 24VDC.

Section 19: β i and β HVi Amplifiers

19.1 Amplifier Electrical Specifications

β i Series Amplifier Specifications

<i>Item</i>	<i>SVM1-20i</i>	<i>SVM1-40i</i>
Power Supply Voltage (amplifier)	3-Phase 200-240VAC ¹ 1-Phase 200-240VAC ²	3-Phase 200-240VAC
Power Supply Voltage (control)	24 VDC /0.9A	24 VDC /0.9A
Dynamic Brake Function ³	Built In	Built In
Built In Regeneration Capacity	16 joule (capacitor energy storage)	50 watt (internal resistor)
External Regeneration Options	20 watt, 30 ohm – ZA06B-6130-H401 100 watt, 30 ohm - ZA06B-6130-H402	200 watt, 16 ohm - ZA06B-6089-H500 800 watt, 16 ohm – ZA06B-6089-H713
Short Circuit Current Rating (SCCR)	85KA	85KA

Notes:

1. 8Nm motor always requires amplifier fan kit ZA06B-6134-K003.
2. 4Nm motor requires amplifier fan kit ZA06B-6134-K003 for single-phase operation only.
3. Dynamic braking activates during servo alarms to stop the motor more quickly than coasting to a stop.

β HVi Series Amplifier Specifications

<i>Item</i>	<i>SVM1-10HVi</i>	<i>SVM1-20HVi</i>	<i>SVM1-40HVi</i>
Power Supply Voltage (amplifier)	3-Phase 400–480VAC	3-Phase 400–480VAC	3-Phase 400–480VAC ¹
Power Supply Voltage (control)	24 VDC/0.9A	24 VDC/0.9A	24 VDC/0.9A
Dynamic Brake Function ²	Built In	Built In	Built In
Built In Regeneration Capacity	16 joule (capacitor energy storage)	50 watt (internal resistor)	50 watt (internal resistor)
Short Circuit Current Rating (SCCR)	85KA	85KA	85KA

Notes:

1. The β SVM1-40HVi amplifier requires fan kit ZA06B-6134-K002 with all motors.
2. Dynamic braking activates during servo alarms to stop the motor more quickly than coasting to a stop.

19.2 β i and β VHi Series Amplifier Environmental Specifications

Item	Specification
Ambient Temperature Operation	0 to 55 °C
Storage	-20 to 60 °C
Humidity	90% RH or below (non-condensing)
Vibration	Below 0.5 G

Temperature Derating

Consider derating as shown below, according to ambient operating temperatures.

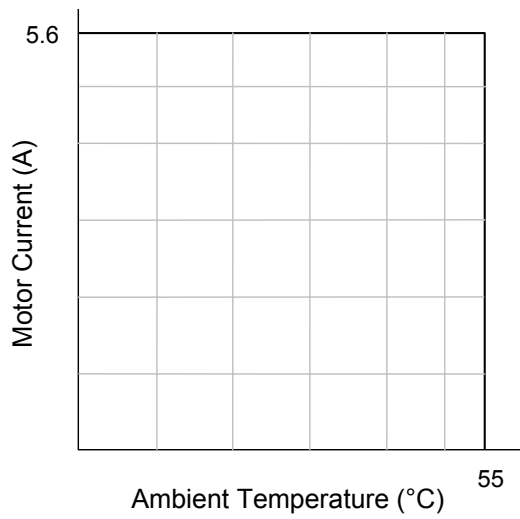

β SVM1-20HVi

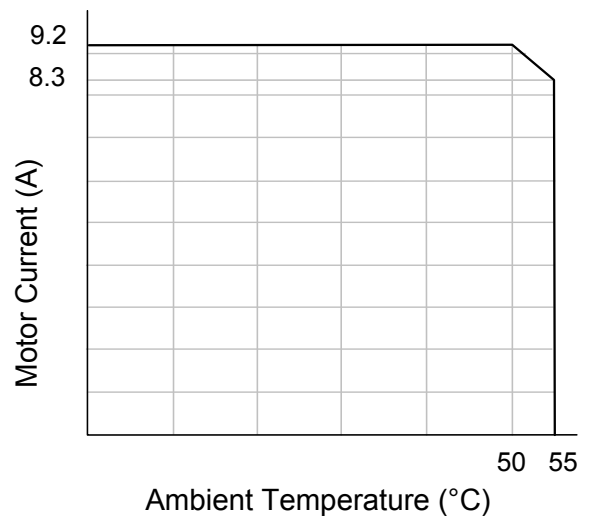

β SVM1-40HVi

19.3 β i & β HVi Series Amplifier Status LED and Alarm Functions

The Servo Amplifier Unit can detect error conditions and provide alarm information.

The LEDs on the front of the amplifier provide a visual cue to the status of the system by indicating, for example, when the motor and amplifier are ready to function.

- POWER LED (green) indicates the logic 24 VDC power is present.
- DC LINK CHARGED LED (red) indicates that the amplifier has high (motor) voltage DC present.
- LINK LED (green) indicates that the FSSB (fiber optic) interface is functioning.
- ALM LED (yellow) is turned ON when an alarm condition is detected. When an alarm is detected, power is dropped and the motor is stopped by dynamic braking action. Alarm information is additionally displayed as diagnostic data in the DSM324i motion controller. The amplifier control power must be cycled to reset this alarm state. The table below details the alarm conditions the β i Series Servo Amplifier System can detect.

Servo Products Specification Guide

Table 3-11. β i and β HVi Series Servo Amplifier Alarms

Alarm Condition	Description
DC Link Under-Voltage	Issued when the DC voltage in the main circuit power supply is abnormally low. Indicates low AC mains power dip or hardware problem. Make sure the plug-in (gray faceplate) circuit board is securely seated in the amplifier base. Replace amplifier.
DC Link Over-Voltage	Issued when the DC voltage in the main circuit power supply is abnormally high. Indicates high AC mains power or hardware problem. Make sure the plug-in (gray faceplate) circuit board is securely seated in the amplifier base. May also be caused by excessive regenerated power. Increase acceleration/deceleration time and/or add additional regenerative discharge capacity. Replace amplifier.
Excessive Deceleration Power	<p>If no external regeneration resistor is used, the discharge resistor thermal sensor jumper is missing on connector CXA20. This input requires a normally closed contact for normal operation.</p> <p>When using an external regeneration resistor, the thermal sensor in the regeneration resistor has tripped. Indicating excessive regenerated power load to the regeneration resistor. Use a meter to confirm an open circuit on the thermal sensor leads. Make sure the plug-in (gray faceplate) circuit board is securely seated in the amplifier base. Increase capacity of external regeneration resistor or decrease deceleration rate or frequency, and/or the top speed from which the axis must decelerate.</p>
Control Power Under-Voltage	The 24 VDC control power is below 21.6 VDC. Check the supply voltage level and make sure the CXA19A and CXA19B connectors are secure and associated cables are wired correctly. Replace amplifier.
Internal Cooling Fan Stopped	Fan is jammed, has failed or is not connected. Check for foreign material in fan blades. Make sure fan is plugged in. Make sure the plug-in (gray faceplate) circuit board is securely seated in the amplifier base. Replace amplifier.
IPM Alarm	Excessive current in the power transistors. Phase to phase or phase to ground short circuit on motor power output. Make sure the plug-in (gray faceplate) circuit board is securely seated in the amplifier base. Possible incorrect phase connection of the motor power wiring. Motor type code must be configured correctly in the GE Intelligent Platforms controller. Disconnect motor power leads from amplifier and reset E-stop condition. If IPM alarm occurs replace amplifier. If no IPM alarm the problem is in the motor or motor power cable. Check for electrical shorts in the motor power cable or motor winding shorted to frame ground.
IPM Overheat	Issued when the temperature inside the amplifier becomes so high that the thermostat trips. Make sure the plug-in (gray faceplate) circuit board is securely seated in the amplifier base. Check that the heat sink cooling fan (if applicable) is running. Make sure the ambient temperature around the amplifier is 55°C or lower. Check that the motor load is within the rating of the motor.
Motor Over-current	Issued when an abnormally high current is detected in the main circuit. Make sure the plug-in (gray faceplate) circuit board is securely seated in the amplifier base. Check for electrical shorts in the motor power cable or motor winding shorted to frame ground. Possible incorrect phasing on motor power wiring. Motor type code may be configured incorrectly in the DSM324i controller. Possible excessive force loading on motor.
FSSB Communication Error	FSSB connector or cable failure. Check the connections to the COP10A and COP10B connectors. Try replacing the optical cable. Replace amplifier.

19.4 Amplifier External Dimensions

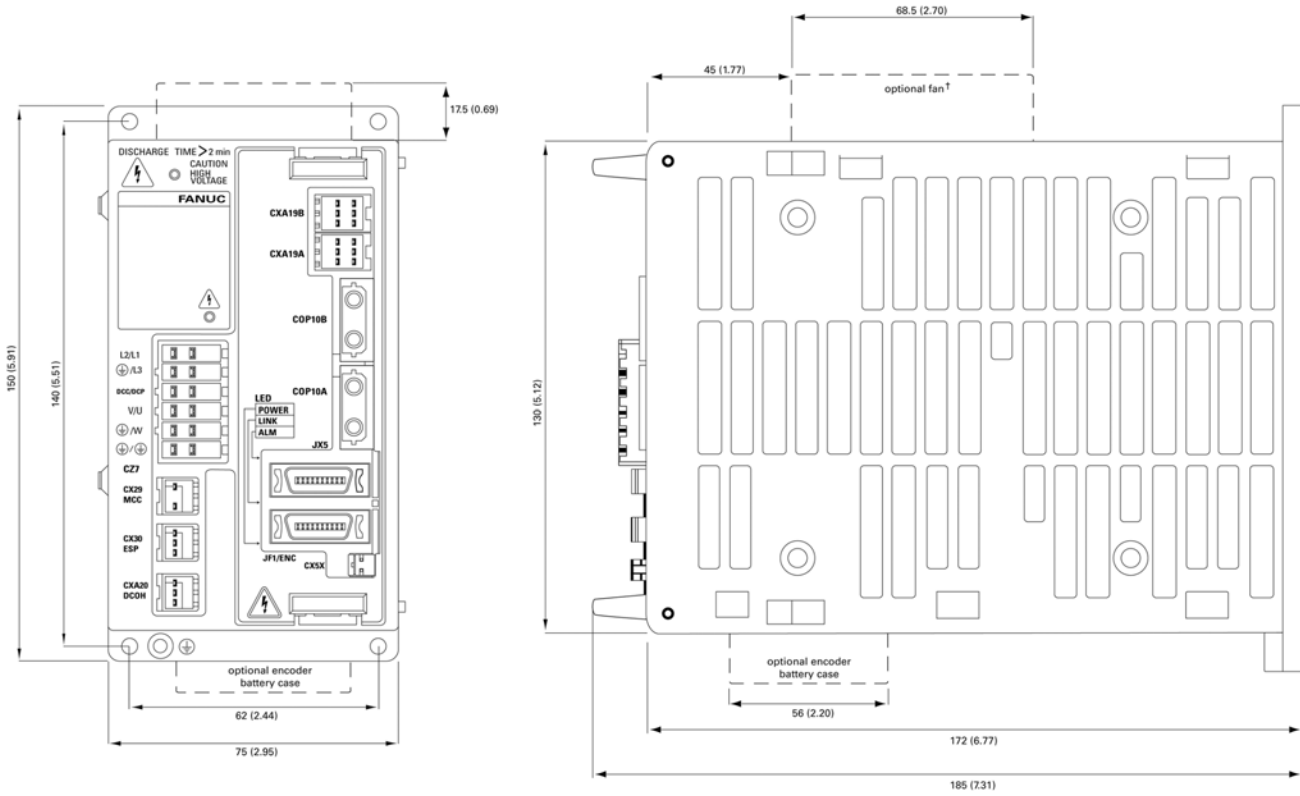

Figure III-9. External Dimensions of β SVM1-20i Amplifier

Servo Products Specification Guide

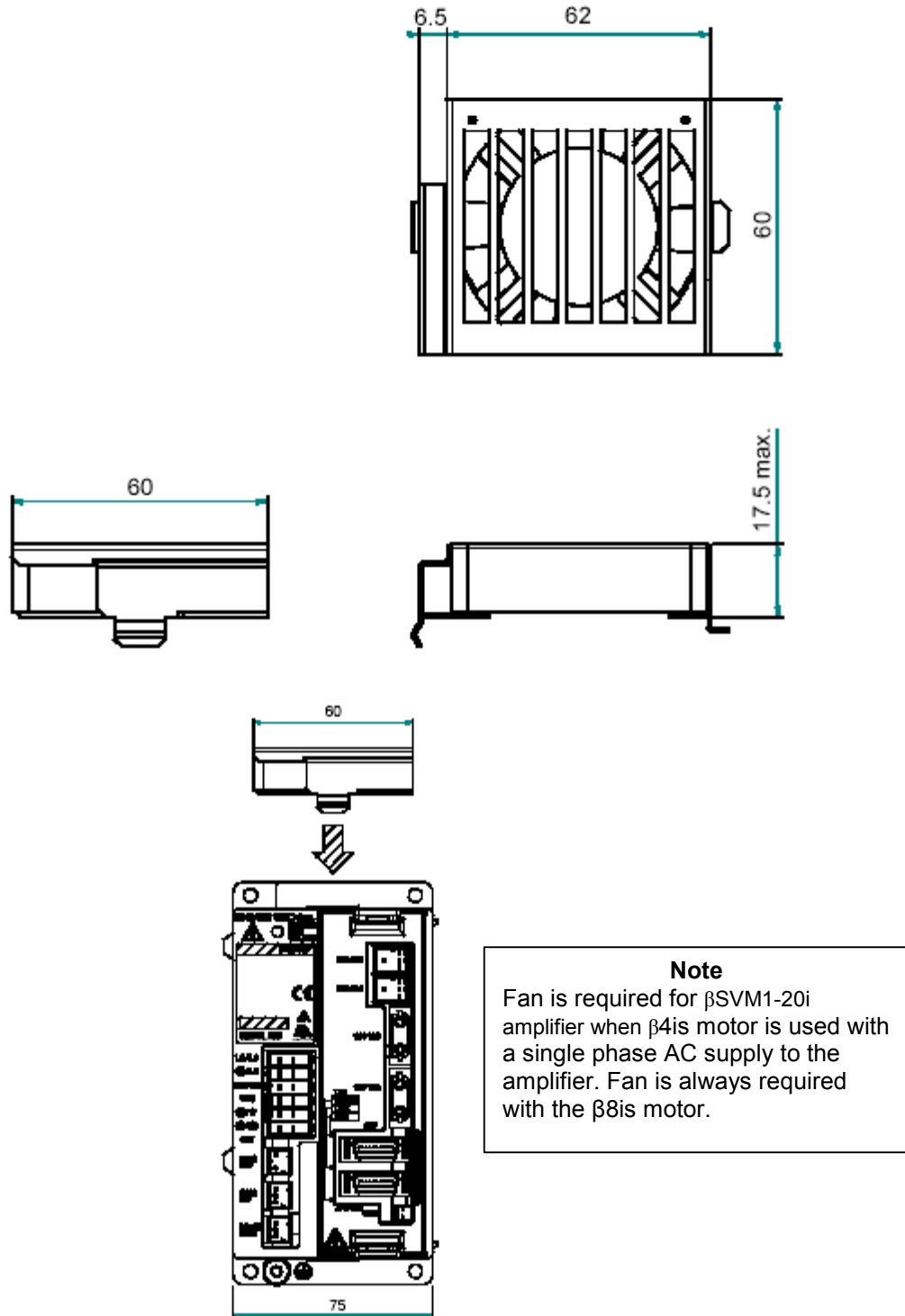

Figure III-10. External Dimensions of Optional Cooling Fan Unit (ZA06B-6134-K003) for β SVM1-20i Amplifier

Servo Products Specification Guide

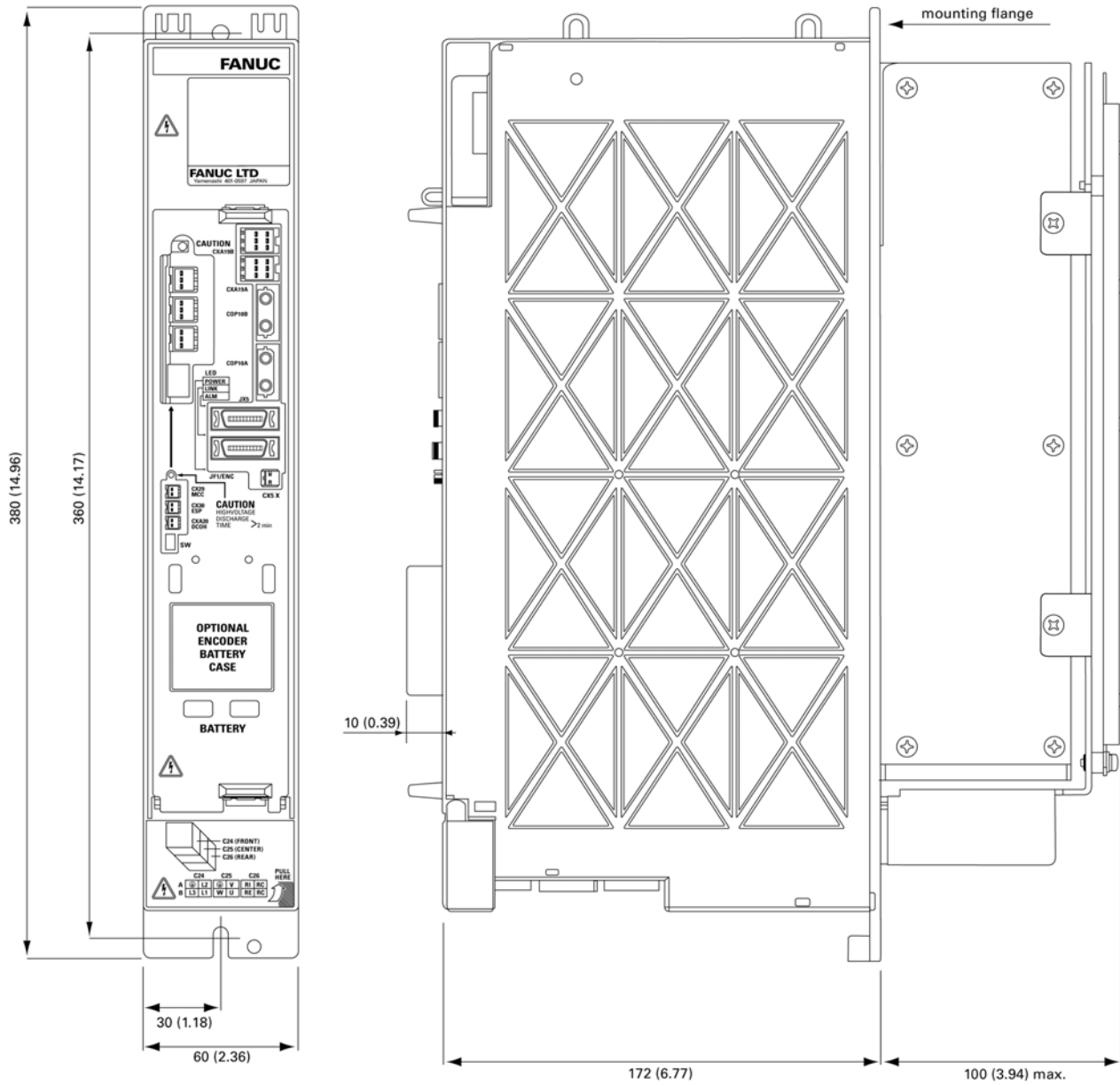

Figure III-11. External Dimensions of β SVM1-40i, β SVM1-10HVi, β SVM1-20HVi and β SVM1-40HVi Amplifiers

Servo Products Specification Guide

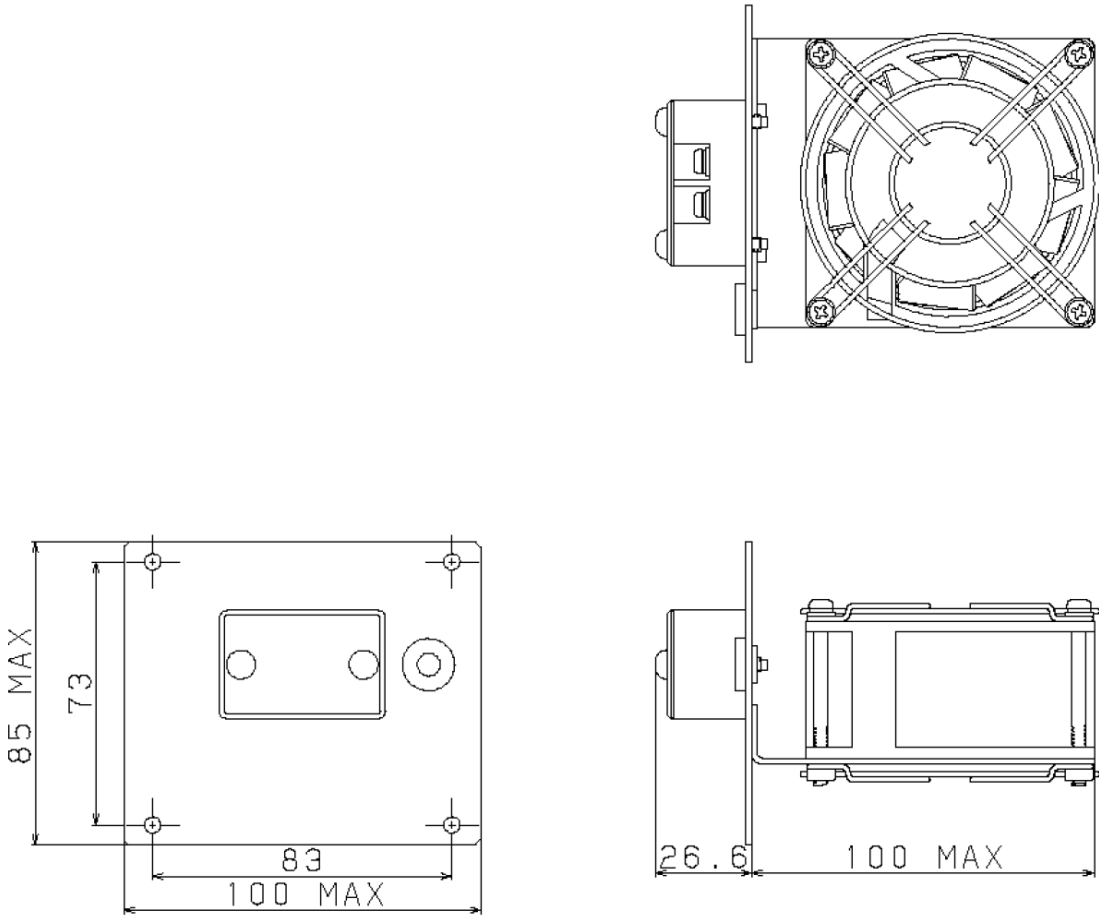

Figure III-12. External Dimensions of Optional Cooling Fan Unit (ZA06B-6134-K002) for β SVM1-40i Amplifier

Servo Products Specification Guide

When a cooling fan is required, install the fan motor in the order (1), (2), and (3) as illustrated below.

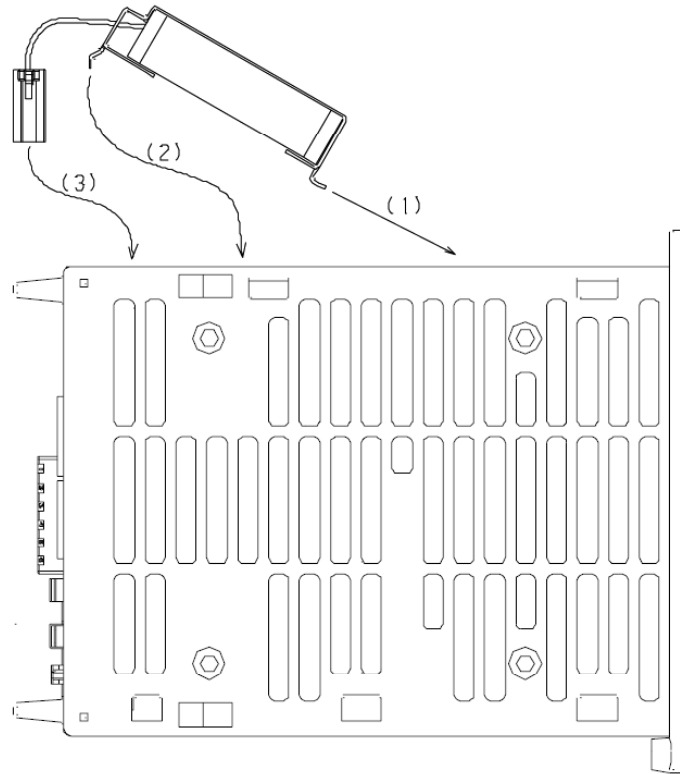

Figure III-13. Fan Installation

19.5 Absolute Encoder Battery Options

All β is and β HVi Series servomotors feature a built-in encoder that can be used in either incremental or absolute mode. To utilize the absolute capability, an optional encoder battery pack must be installed. This pack allows the encoder's position information to be maintained so that the machine does not need to be re-referenced to a home position every time power is restored to the servo system.

The encoder for β is 0.4 to 22 Nm motors and all β HVi motors contains an integral capacitor that will maintain the encoder backup voltage for approximately 10 minutes. This allows battery change without loss of absolute position data.

There are two encoder battery backup options for the β i and β HVi Series amplifiers. A snap-on lithium battery pack that will support a single amplifier or a panel mounted battery pack for up to four amplifiers that uses standard D cell alkaline batteries.

For optimal panel space utilization, a small lithium battery pack IC800BBK021 is available that snaps onto the β i and β HVi Series amplifiers housing (see figure below). An integral pigtail cable plugs directly into the CX5X connector on the faceplate of the amplifier. One battery is required for each β i or β HVi Series amplifier. The lithium battery service life is approximately 2 years.

The Absolute Encoder Battery Kit (IC800BBK021) contains the following:

- Qty 1 - Battery (ZA06B-6093-K001)
- Qty 1 - Battery Holder (ZA06B-6093-K002)

Connection Method for Separate Lithium Battery for Each Amplifier

Installation

1. Make sure 24V control power is applied to the amplifier (if trying to hold position on an existing system)
2. Place system in an E-stop condition
3. Remove AC power from the amplifier
4. Remove the old battery (if applicable)
5. Place battery into plastic cover
6. Snap cover onto amplifier housing
7. Attach battery cable to amplifier CX5X connector as indicated in diagram making sure polarity is correct.

Note

- Do not attempt to connect multiple amplifiers to one IC800BBK021 battery kit.
- Replacement CX5 battery connectors are available as kit number ZA06B-6093-K303

Servo Products Specification Guide

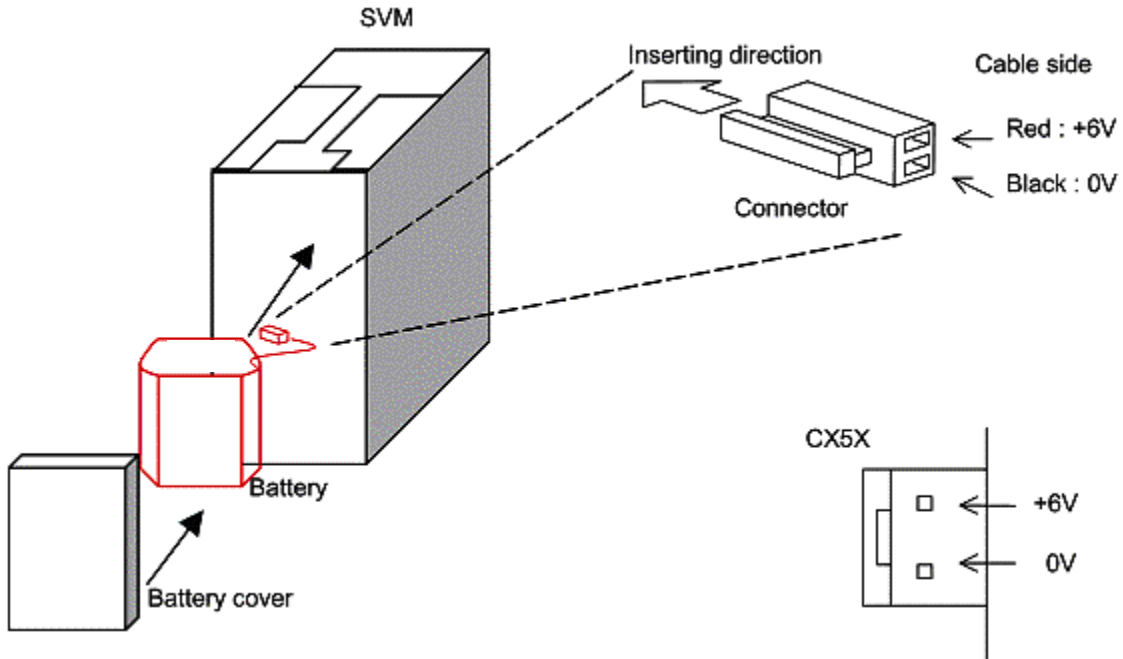

β SVM1-20i Amplifier

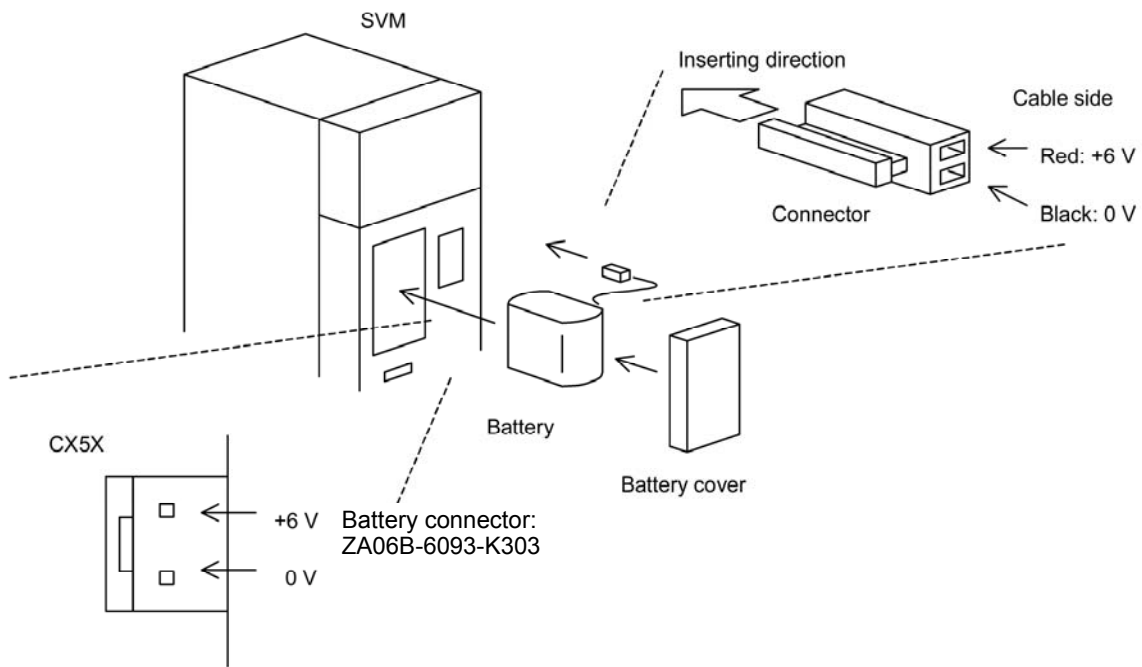

β SVM1-40i, β SVM1-10HVi and β SVM1-20HVi Amplifiers

Figure III-14. Installing the IC800BBK021 Absolute Encoder Battery Pack (One-Axis)

Connection Methods for Multiple Amplifiers

To utilize the absolute capability for multiple amplifiers (β SVM1-20i, β SVM1-40i, β SVM1-10HVi or β SVM1-20HVi) the IC800ABK001 panel mounted battery pack must be installed. One kit provides battery backup for up to four absolute encoders.

The Absolute Encoder Battery Kit (IC800ABK001) contains the following:

- One battery holder (ZA06B-6050-K060)
- Four D-cell, alkaline batteries (ZA98L-0031-0005)

The user is responsible for manufacturing the cable used to connect the battery pack to the amplifier. The battery connection is made to the CXA19B connector on the last amplifier in the sequence supported by the battery pack. Terminals CXA19B-B3 (6V) and CXA19B-A2 (0V) are used and wire should be 0.3 mm² minimum cross sectional area. The battery power is distributed to the other amplifiers in the sequence by daisy chaining the CXA19A connections to the CXA19B connections on adjacent amplifiers. The E-Stop signals are also daisy chained.

See Section 24: β i and β HVi Series Servo System Connection an overview of amplifier connections.

The battery service life is approximately one year and we recommend a yearly replacement schedule.

The IC800ABK001 battery pack is panel-mounted and requires a cutout in the mounting surface. Mounting dimensions and terminal designations are shown below.

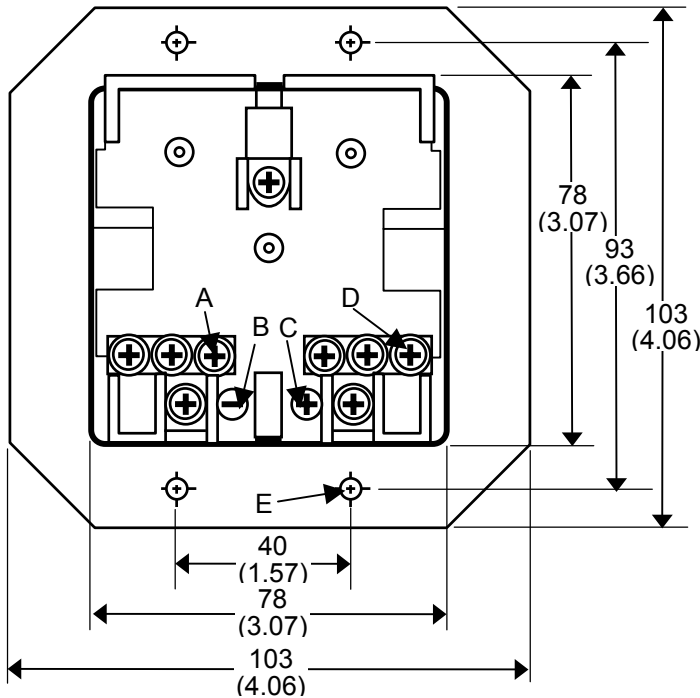

All dimensions in mm (in)

A	3-M3 negative terminal
B	Negative terminal indication
C	Positive terminal indication
D	3-M3 positive terminal
E	4- \varnothing 4.3 (0.169) mounting holes

Figure III-15. Absolute Encoder Battery Pack IC800ABK001 (up to Four Axes)

Servo Products Specification Guide

Warning

Wiring 24VDC to the incorrect pins will cause amplifier and motor damage. Always confirm proper voltage on the pins before connecting the cable.

Warnings

When connecting two or more servo amplifiers, be careful about the way the ESP (A3) signal is connected, because even when the emergency stop button is pressed, it may fail to stop the motor promptly. For details, see "Details of Cable K8" on page III-93.

When using the built-in battery (A06B-6093-K001), never connect the BAT (B3) of the connector CXA19A/CXA19B. Otherwise, a short circuit will occur between the battery output voltages for different SVMs, possibly resulting in the batteries becoming very hot, which is dangerous.

Do not connect more than one battery to the same BAT (B3) line. Otherwise, a short circuit will occur between the output voltages of different batteries, possibly resulting in the batteries becoming very hot, which is dangerous.

Multiple Amplifiers with External Encoder Battery Pack

In the following sample configuration, the 24V control signals, emergency stop signal and battery power are daisy-chained from CXA19A to CXA19B. Note that the A1-B1 and A2-B2 wires are redundant: Even though only one set is required, the second set can be installed to carry any additional current to downstream amplifiers.

The A3 (ESP) wire is daisy chained so that all amps will be emergency stopped if the ESP signal is true.

The B3 (BAT) connections distribute battery power to all the amplifiers in the daisy chain.

For more information, see “Details of Cable K-6” on page III-90.

A1	+24VDC
A2	0 VDC (common)
A3	Emergency stop (ESP) - <i>optional</i>
B1	+24VDC - <i>optional</i>
B2	0 VDC (common) - <i>optional</i>
B3	Battery (BAT) - <i>optional</i>

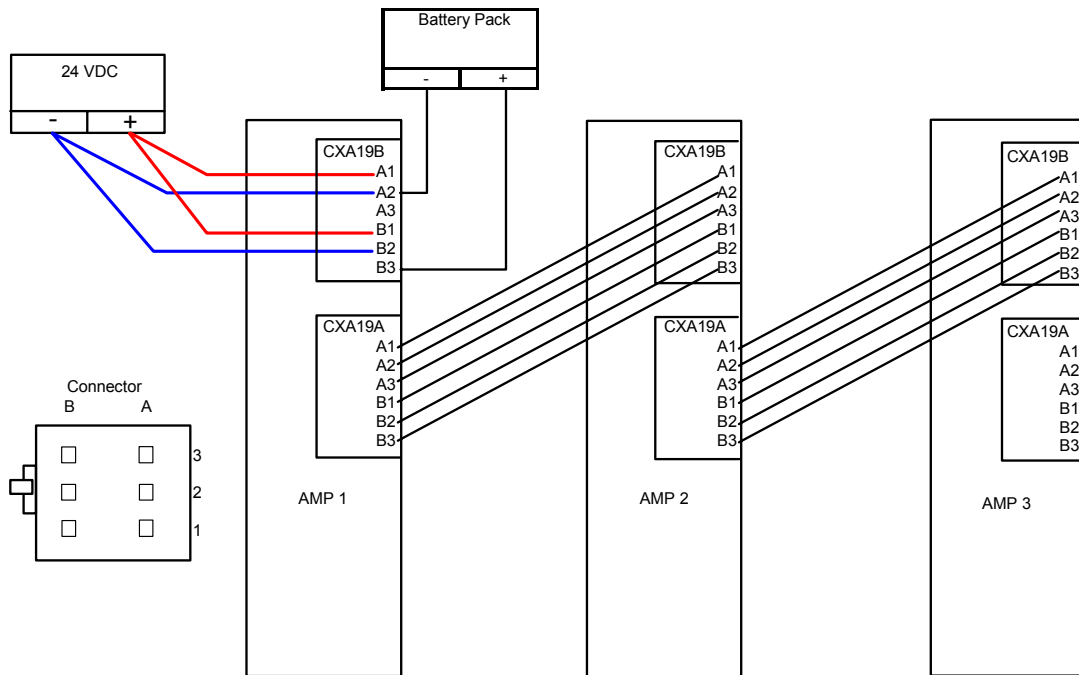

Figure III-16. Multiple Amplifiers with External Encoder Battery Pack

Multiple Amplifiers with Separate Encoder Batteries

In the following configuration, the daisy-chained BAT connections are removed from CXA19A-B3 and CXA19B-B3. The 24VDC and E-stop signals are still daisy-chained.

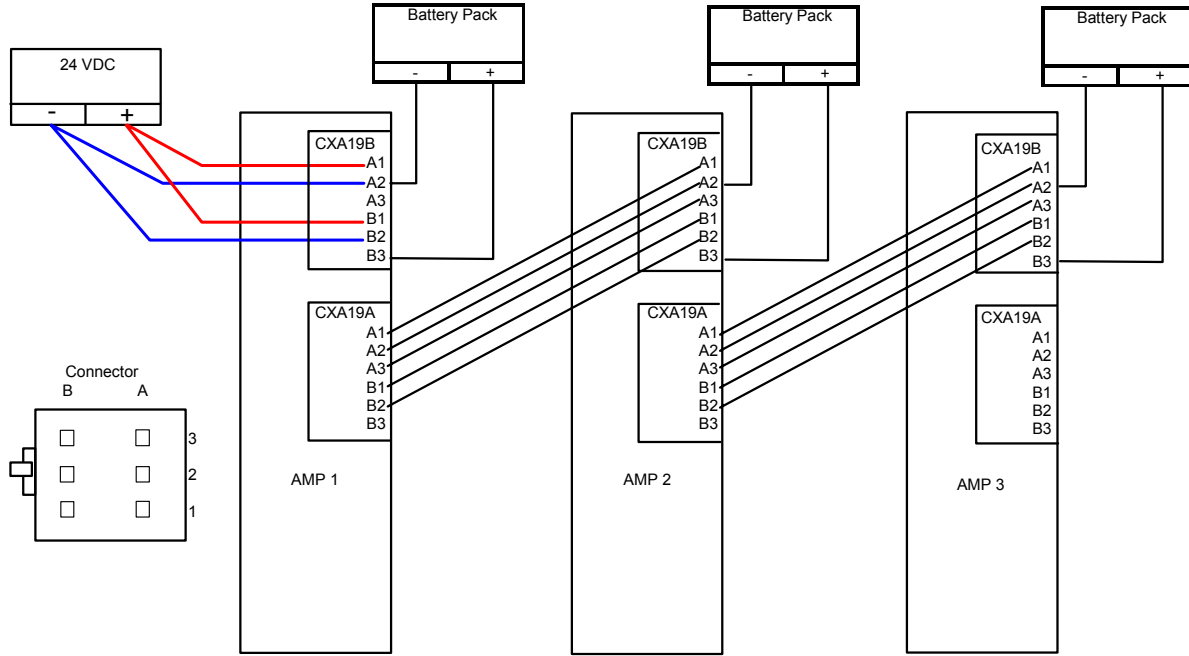

Figure III-17. Multiple Amplifiers with Separate Encoder Batteries

Multiple Amplifiers with no Battery Pack

In this configuration, which does not use battery backup, the 24VDC and E-stop signals are daisy-chained. The BAT (B3) connections are removed.

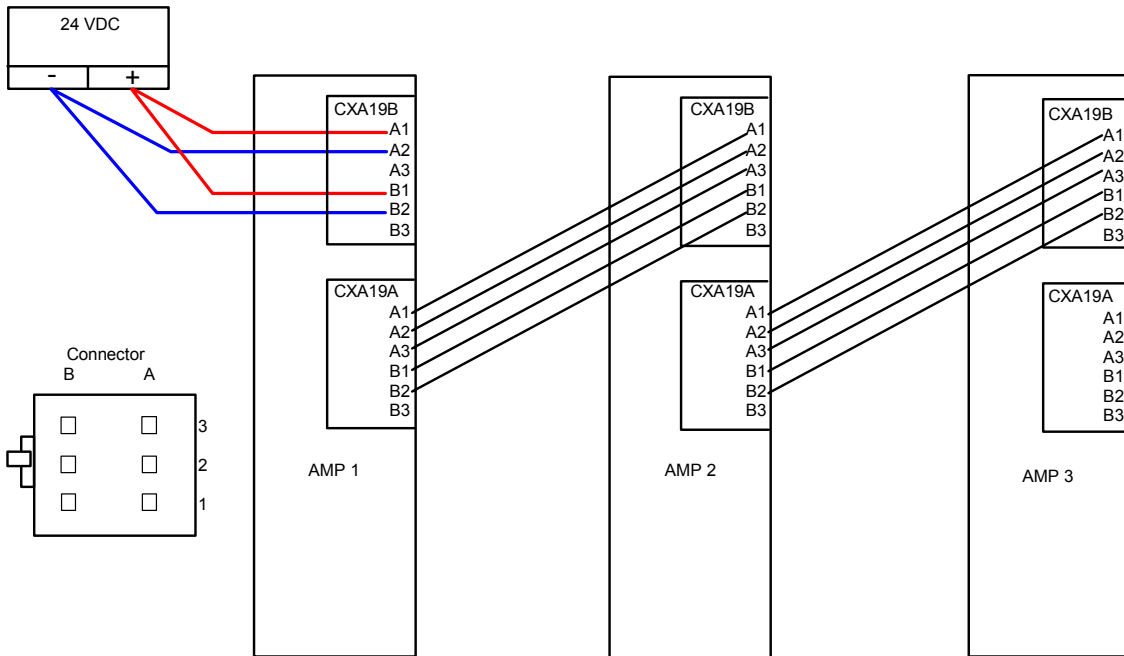

Figure III-18. Multiple Amplifiers with no Battery Pack

Section 20: Installation Guidelines

This section includes environmental requirements, motor and amplifier dimension drawings and information on ensuring noise protection and selecting a ground fault interrupter.

20.1 β is and β HVi Motor Environmental Requirements

The servomotor must be installed in a location that satisfies the following environmental conditions:

Table 3-12. Servo Motor Environmental Conditions

Condition	Description
Ambient temperature	The ambient temperature should be 0°C to 40°C. When operating the motor at a temperature higher than 40°C, it is necessary to de-rate the output power so that the motor's and the encoder's temperature rating is not exceeded.
Ambient humidity	Should be 80% RH (relative humidity) or less, non-condensing
Vibration	When installed in a machine, the vibration applied to the motor must not exceed 5G.
Altitude	No more than 1,000 m (3,300 ft) above sea level.
Drip-Proof Environment	The motors have a drip-proof structure that complies with IP65 of the IEC standard. Nevertheless, to ensure long-term performance, the motor surface should be protected from solvents, lubricants, and fluid spray. A cover should be used when there is a possibility of wetting the motor surface. Also, to prevent fluid from being led to the motor through the cable, put a drip loop in the cable when the motor is mounted. Finally, turn the motor connector sideways or downward as far as possible. If the cable connector will be subjected to moisture, it is recommended that an R class or waterproof plug be used. For additional information, see <i>Servo and Spindle Motors Exposed to Liquids</i> , GFK-1046.

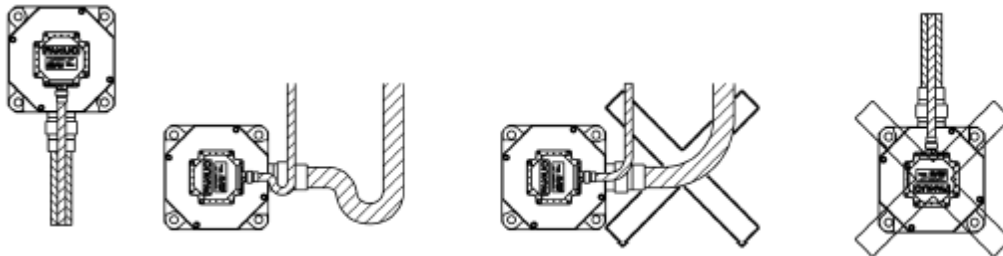

Figure III-19. Motor Installation for Drip-Proof environment

20.2 β is & β HVi Servo Amplifier Environmental Requirements

The servo amplifier must be installed in a location that satisfies the environmental conditions identified in the table below.

Table 3-13. Servo Amplifier Environmental Conditions

Condition	Description
Ambient temperature	0°C to 55°C (operating). -20°C to 60°C (storage and transportation).
Temperature fluctuation	Within 1.1°C/min.
Humidity	90% RH (non-condensing) or lower.
Altitude	No more than 1000 m (3,300 ft) above sea level.
Vibration	No more than 0.5 G during operation.
Atmosphere	The circuitry and cooling fins must not be exposed to any corrosive and conductive vapor or liquid.

The amplifier must be installed in a cabinet that protects it from contaminants such as dust, coolant, organic solvents, acid, corrosive gas, and salt. Adequate protection must also be provided for applications where the amplifier could be exposed to radiation, such as microwave, ultraviolet, laser light, or x-rays.

To adequately protect the amplifier, you must ensure that:

- Contaminants such as dust and fluid cannot enter through the air inlet or outlet.
- The flow of cooling air is not obstructed.
- The amplifier can be accessed for inspection.
- The amplifier can be disassembled for maintenance and later reinstalled.
- There is sufficient separation between the power and signal lines to avoid interference. Noise protection should be provided.

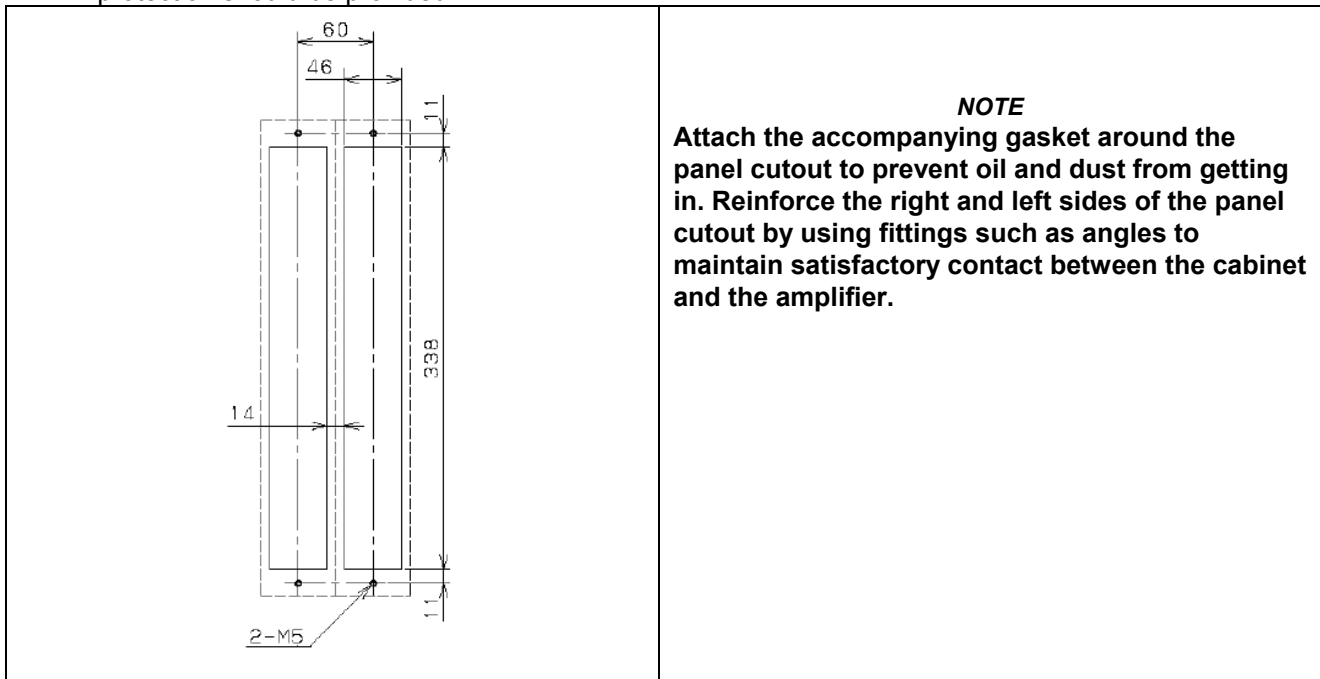

Figure III-20. Panel Cut-out Drawing for Through-Cabinet Mounting of the β SVM1-40i, β SVM10HVi and β SVM1-20HVi Amplifiers

20.3 β i and β HVi Amplifier Heat Dissipation and Maintenance Clearance

The amplifier may contain a cooling fan that forces air through the unit. Allow for adequate clearance for airflow when installing the amplifier using the recommended distances shown in the drawings below. If possible, do not mount amplifiers one above the other unless they are staggered to prevent the heated exhaust of the lower unit from flowing over the upper unit.

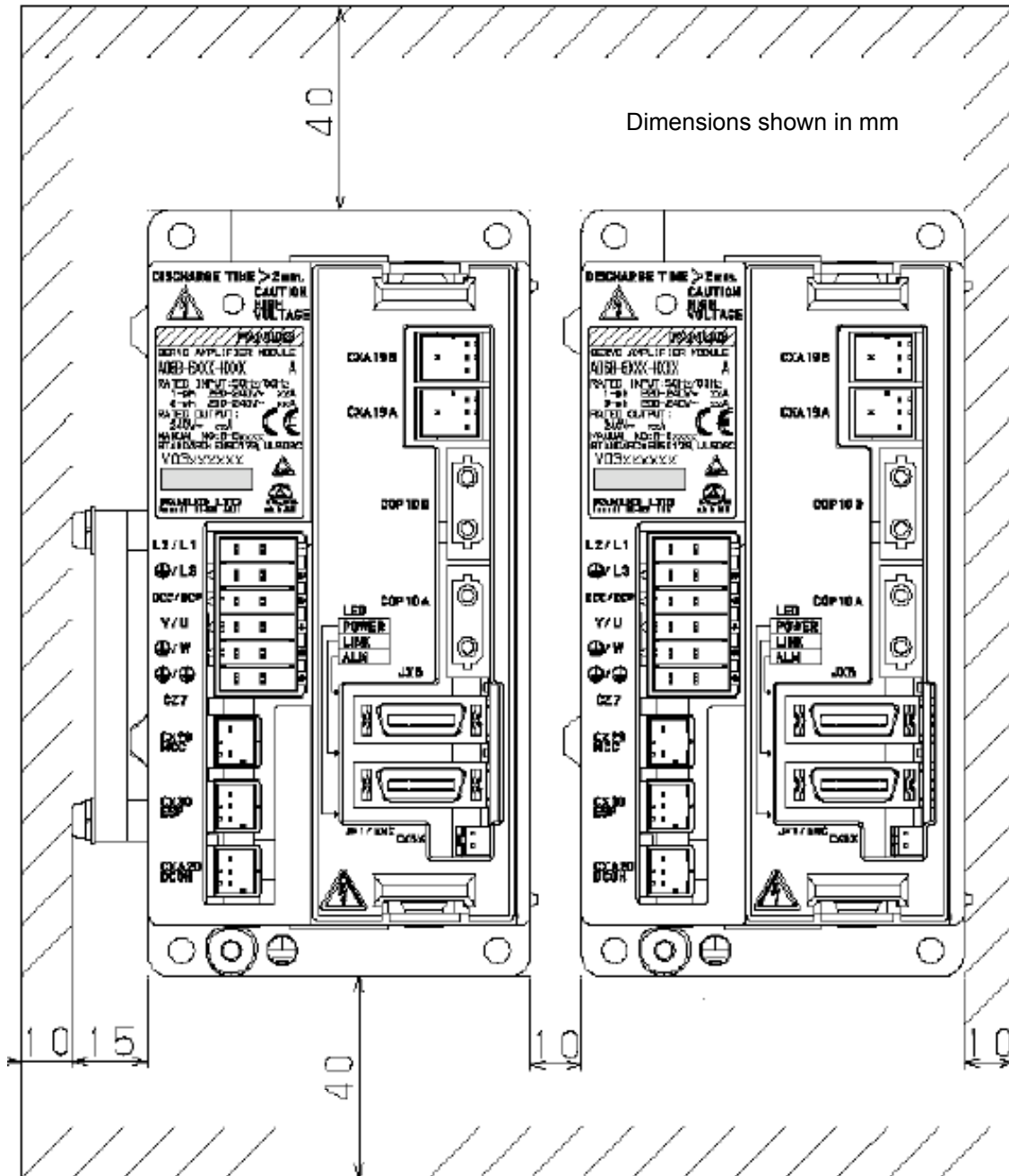

Figure III-21. Maintenance Clearance for Amplifier β SVM1-20i

Servo Products Specification Guide

Dimensions shown in mm

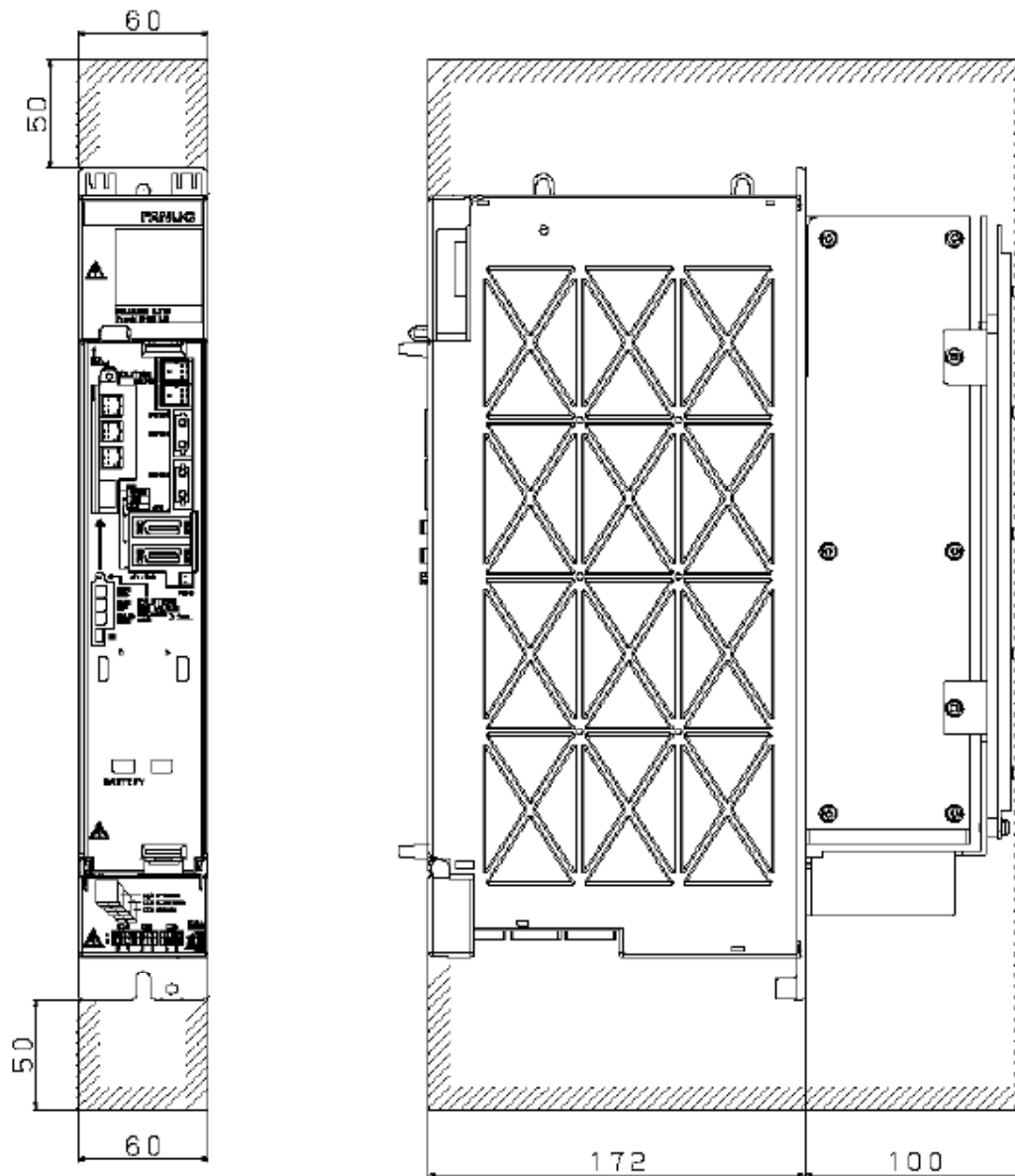

Figure III-22. β i Series β SVM1-40i, β SVM1-10HV, β SVM1-20HV and β SVM1-40HV Amplifier Maintenance Clearances

Section 21: Heat Dissipation

Table 3-14 identifies worst-case heat dissipation values for each amplifier. These values may be used to determine heat load for sizing enclosures and cooling equipment. Heat dissipation for external regeneration resistors depends on the application and is calculated in 23.7, Step 5.

The total heat dissipation is a function of the amplifier base dissipation (a) plus the amplifier heat coefficient (K) times the heat generated by RMS stall current flowing through the servo motor (b).

$$\text{Total heat dissipation Watts} = a + (K * b)$$

Table 3-14. In Cabinet Heat Dissipation

<i>Amplifier</i>	<i>Catalog #</i>	<i>Amplifier base heat dissipation (a)</i>	<i>Amplifier heat coefficient (K)</i>	<i>Motor Model</i>	<i>Motor Current (b) [Arms]</i>	<i>Total heat dissipation [Watts]</i>
βSVM1-20i	ZA06B-6130-H002	20 watt	7.7	β0.4/5000is	3.6	47.7
				β0.5/6000is	2.9	42.3
				β1/6000is	2.7	40.8
				β2/4000is	3.3	45.4
				β4/4000is	4.7	56.2
				β8/3000is	6	66.2
βSVM1-40i	ZA06B-6130-H003	20 watt	7.1 (heat sink in cabinet)	β12/3000is	10.2	92.4
				β22/2000is	11.3	100.2
			1.4 (heat sink external to cabinet)	β12/3000is	10.2	34.2
				β22/2000is	11.3	35.8
βSVM1-10HVi	ZA06B-6131-H001	20 watt	10.8 (heat sink in cabinet)	β2/4000 HVis	1.6	37.3
				β4/4000 HVis	2.3	44.8
				β8/3000 HVis	3.0	52.4
			2.2 (heat sink external to cabinet)	β2/4000 HVis	1.6	23.5
				β4/4000 HVis	2.3	25.1
				β8/3000 HVis	3.0	26.6
βSVM1-20HVi	ZA06B-6131-H002	20 watt	11.1 (heat sink in cabinet)	β12/3000 HVis	5.1	76.6
				β22/2000 HVis	5.6	82.2
			2.2 (heat sink external to cabinet)	β12/3000 HVis	5.1	31.2
				β22/2000 HVis	5.6	32.3
βSVM1-40HVi	ZA06B-6131-H003	20 watt	11.1 (heat sink in cabinet)	β12/3000 HVis		
				β22/2000 HVis		
			1.1 (heat sink external to cabinet)	β12/3000 HVis		
				β22/2000 HVis		

Section 22: Noise Protection

22.1 Separation of Signal and Power Lines

When routing signal and power lines, the signal lines must be separated from the power lines to ensure best noise immunity. The table below lists the types of cables used:

Table 3-15. Servo amplifier signal line separation

Group	Signal	Action
A	Amplifier input power line, motor power line, MCC drive coil	Separate these cables from those of group B by bundling them separately* or by means of electromagnetic shielding**. Attach a noise suppressor (spark arrester) to the MCC drive coil.
B	Cable connecting control unit with servo amplifier and serial encoder feedback cable	Separate these cables from those of group A by bundling them separately or by means of electromagnetic shielding**. In addition, shielding must be provided.

* The bundle of group A cables must be separated from the bundle of group B cables by at least 10 cm.

** Electromagnetic shielding involves shielding groups from each other by means of a grounded metal (steel) plate.

22.2 Grounding

A typical machine has three separate grounds:

- **Signal Ground:** Provides the reference potential (0 V) for the electrical signal system.
- **Frame Ground:** Ensures safety and shields external and internal noise.
- **System Ground:** Connects each unit and the inter-unit frame ground system to earth ground.

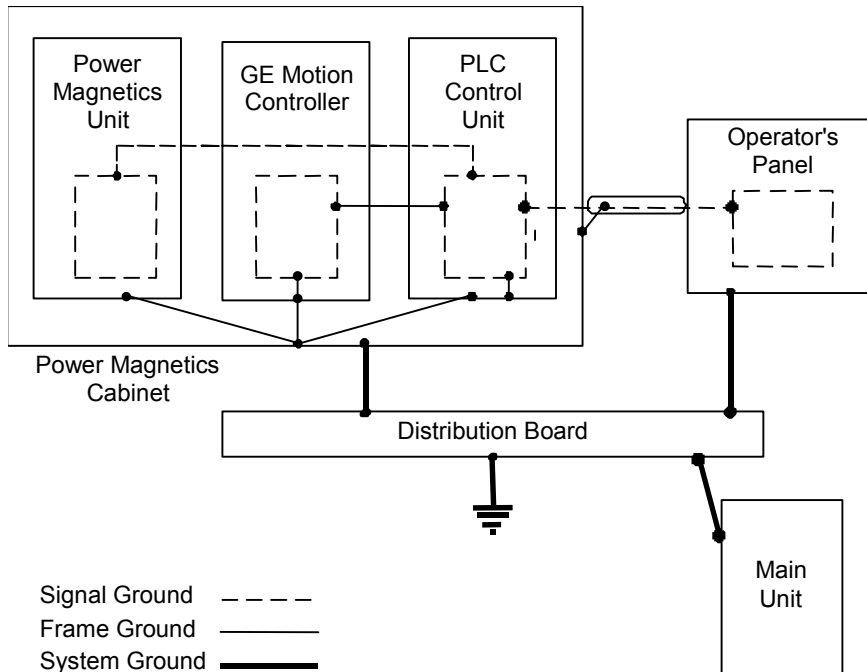

Figure III-23. Ground System

Servo Products Specification Guide

Notes on the ground system wiring:

- The ground resistance of the system ground must not exceed 100 ohms (Class-3 ground).
- System ground connection cables must have a sufficiently large cross-sectional area to enable them to safely carry the current that will arise in the event of a problem such as a short-circuit (in general, a cross-sectional area no less than that of the AC power line must be provided).
- The system ground connection cable must be integrated with the AC power line such that power cannot be supplied if the ground wire is disconnected.
- The SVM1-20i CZ7-3 motor power connector servo motor frame ground connection on pin A2 should always be installed.
- The motor frame must be referenced to earth ground with a class 3 (100 ohms or less) system ground. Use an ohmmeter to measure the resistance from the servomotor frame to a known earth ground rod or grid. When using the 20 amp amplifier (SVM-20i), the servo motor frame ground connection on connector CZ7-3 pin A2 should always be installed. The frame-to-ground resistance should be within 1 to 2 ohms.
In a high noise environment, installing a ground wire on the motor frame and routing it directly to the nearest available earth ground can improve noise immunity. Some servo motors have a tapped hole on the frame or a blind hole that can be tapped. For smaller motors, connect to the motor mounting bolts.
- The Motor Power cable should not be a shielded cable. If a custom built cable with shield was used for motor power, lift the shield connection at both ends of the cable. If a shield is attached, especially at the motor end, it acts as an antenna to couple noise into the encoder.
- The Motor Feedback cable should have the Z44B295864-001 Grounding Bar and one ZA99L-0035-001 Grounding Clamp per axis installed near the amplifier. Confirm that the grounding bar is referenced to earth ground with a class 3 (100 ohms or less) system ground. Use an ohmmeter to measure the resistance from the grounding bar frame to a known earth ground rod or grid. The frame to ground resistance should be within 1 to 2 ohms.
In a high noise environment, installing a ferrous bead on the feedback cable within a short distance of the amplifier connector can also improve noise immunity.
- Separation of Motor Power and Motor Feedback cables: Group A signals (Amplifier main AC power, Motor Power Cable and MCC drive coil) signals must be separated from Group B signals (Motor Feedback cable) by at least a 10cm distance. Do not tie Group A and B signals together with cable ties or wraps at any point. An alternative is to separate these two groups by means of a grounded metal (steel) plate.
- The MCC relay used to switch the three-phase AC main power to the amplifier should have an appropriate noise (spark arrester) on its drive coil.
- The 24VDC power supply used to supply the logic power to the amplifiers should be a regulated supply free of excessive noise. If possible examine the DC voltage with an oscilloscope for noise. If a 24 VDC motor-mounted holding brake is used, it should not use the same power supply as the control logic power.

Servo Products Specification Guide

- An AC line filter is recommended to suppress high frequency line noise on the amplifier main power lines. When an isolation transformer is used to convert AC main power to amplifier input power levels, the AC line filter is not required. GE Intelligent Platforms supplies an acceptable three-phase line filter sized for 5.4KW or 10.5KW especially for this purpose. This filtered AC main power should not be shared with other equipment in the panel, especially with devices such as inverter drives or motor starters that have high power consumption.
- Amplifier Chassis Ground must be referenced to earth ground with a class 3 (100 ohm or less) system ground. Use an ohmmeter to measure the resistance from the amplifier frame to a known earth ground rod or grid. A tapped and threaded hole is provided on the amplifier frame for this purpose.
- AC Main PE Ground is supplied in accordance to local code practices and may vary, depending on AC power distribution in the facility. In general the PE ground should be referenced to an earth ground and not indicate common mode voltage to the instrumentation earth ground.

22.3 Encoder Feedback Cable Grounding

The β i Series motor encoder feedback cable shielding should be grounded by the method shown below. This cable clamp treatment provides both cable support (strain relief) and proper grounding of the shield. To ensure stable system operation, the cable clamp method is recommended. Partially peel back the cable sheath to expose the shield. Push the clamp (ZA99L-0035-0001) over the exposed shield and insert the clamp hooks into slots on the grounding bar (Z44B295864-001). Tighten the clamp to secure cable and complete the ground connection. The grounding bar must be attached to a low impedance earth ground.

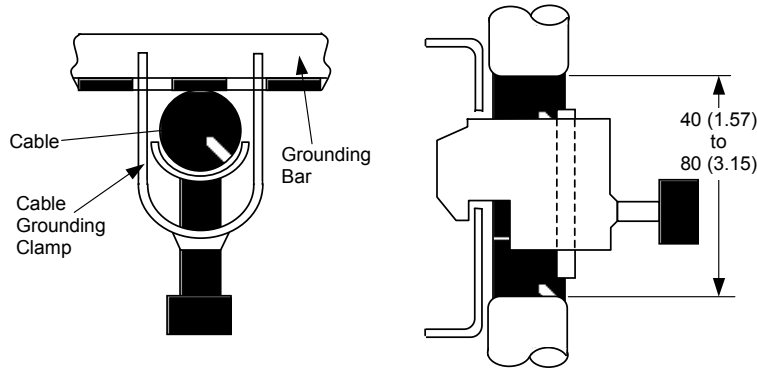

Figure III-24. Cable Grounding Clamp Detail

Note: The grounding bar should be located as close as possible to the amplifier to minimize cable length between amplifier and grounding bar. Observe recommended maintenance clearance.

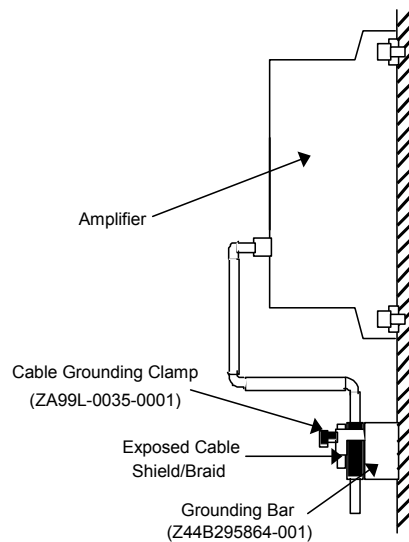

Figure III-25. Feedback Cable Shield Grounding System

Section 23: β i and β HVi Servo System Power Requirements

This section provides information about AC and DC amplifier power as well as the discharge of regenerative power.

23.1 Power Line Protection

A circuit breaker, electromagnetic contactor, and AC line filter or transformer should be installed as part of your β i and β HVi Series Servo system. GE Intelligent Platforms provides the AC line filter as an option. The transformer, circuit breaker, and electromagnetic contactor, however, are user-supplied components. In European countries where power sources are 380 to 400 VAC and neutral grounded, it is necessary to install a transformer or supply single-phase power for the β i Series amplifiers.

The same incoming AC control components can be used to provide power to multiple amplifiers, as long as the components are rated for the current and power drawn by the sum of all of the amplifiers.

23.2 AC Line Filter

An AC line filter is recommended to suppress the influences of high-frequency input line noise on the drive power supply. When an isolation-type power transformer is used because a power supply voltage within the specified range is not available, an AC line filter is not required.

If two or more servo amplifiers are connected to one AC line filter, the total continuous output rating of all connected servo amplifiers should be kept below the continuous output rating of the AC line filter. The continuous output rating for the various servos are shown below.

Table 3-16. β is Servo Motor Continuous Output Rating at Low Line of 200 VAC

<i>Motor</i>	<i>Continuous Output Rating</i>	<i>Motor</i>	<i>Continuous Output Rating</i>
β 0.4/5000is	0.13 KW	β 2/4000HVis	0.5 KW
β 0.5/6000is	0.2 KW	β 4/4000HVis	0.75 KW
β 1/6000is	0.4 KW	β 8/3000HVis	1.2 KW
β 2/4000is	0.5 KW	β 12/3000HVis	1.8 KW
β 4/4000is	0.75 KW	β 22/2000HVis	2.5 KW
β 8/3000is	1.2 KW		
β 12/3000is	1.8 KW		
β 22/2000is	2.5 KW		

If your installation must be EMC compliant, verify that the use of an AC line filter fully satisfies the EMC requirements. You may need to select and install a user-supplied noise filter to meet EMC requirements.

AC line filters are available for GE Intelligent Platforms servo amplifiers:

<i>AC Line Filter</i>	<i>Use With</i>
ZA81L-0001-0083#3C	β i Amplifiers
ZA81L-0001-0101#C	β i Amplifiers
ZA81L-0001-0168	β HVi Amplifiers
ZA81L-0001-0169	β HVi Amplifiers

For AC line filter specifications and dimension drawings, refer to [Section 6.2](#).

23.3 Circuit Breaker Selection

To provide proper protection for the amplifier, use a circuit breaker rated at no more than 20 Amps (10A for VDE 1601 compliance for CE marking). Table 3-17 will help you select the appropriate circuit breaker for your motion application.

Table 3-17. Currents Drawn at Continuous Rated Output at Low Line of 200 VAC

<i>Motor</i>	<i>Input Current 3-phase (Arms)</i>	<i>Input Current Single Phase (Arms)</i>
$\beta 0.4/5000is$	0.7	1.4
$\beta 0.5/6000is$	1.1	2.2
$\beta 1/6000is$	2.1	4.3
$\beta 2/4000is$	2.6	5.4
$\beta 4/4000is$	3.9	8.1
$\beta 8/3000is$	6.3	9.7
$\beta 12/3000is$	9.4	n/a
$\beta 22/2000is$	13.1	n/a
$\beta 2/4000HVis$	1.2	n/a
$\beta 4/4000HVis$	1.7	n/a
$\beta 8/3000HVis$	2.7	n/a
$\beta 12/3000HVis$	4.0	n/a
$\beta 22/2000HVis$	5.6	n/a

Note:

When multiple amplifiers are connected to a single circuit breaker, select a breaker by multiplying the sum of the currents listed in Table 3-17 by 0.6. (This factor attempts to compensate for applications where all axes are not demanding full power at the same time. In applications where all axes are running continuously or with high duty cycles, this factor must be increased to 1.)

Example: Connecting two $\beta 8/3000is$ motors operating on 3-phase power:
 $(6.3 + 6.3) \times 0.6 = 7.6$ Arms

A standard 10 Amp circuit breaker can be used.

During rapid motor acceleration, a peak current that is three times the continuous rating flows. Select a circuit breaker that does not trip when a current that is three times the continuous rating flows for two seconds.

23.4 Electromagnetic Contactor Rating

To prepare for incoming AC power, you must also select and install an appropriate electromagnetic contactor, based on the peak currents for the motors in your system. When multiple amplifiers are connected to a single circuit breaker, select a breaker based on the sum of the motor currents in Table 3-17.

23.5 Incoming AC power

Table 3-18. AC Power

<i>Specification</i>	<i>βi Amplifiers</i>	<i>βHVi Amplifiers</i>
Voltage: 3-phase (+10%, -15%) 1-phase (+10%, -15%)	200 VAC to 240 VAC 220 VAC to 240 VAC	400—480 VAC n/a
Frequency	50 Hz/60Hz ± 2 Hz	50 Hz/60Hz ± 2 Hz
Voltage fluctuation during acceleration/deceleration	7% or less	7% or less

AC Power Ratings

The power supply rating required when using multiple servo motors can be determined by summing the requirements of the individual motors.

The power supply ratings listed in Table 3-19 are sufficient as continuous ratings. Note, however, that servo motor acceleration causes a current to momentarily flow that is approximately three times the continuous current rating.

When the power is turned on, a surge current of about 37A (when 264VAC is applied) flows for 20 msec.

Table 3-19. Three-Phase Power Supply Ratings

<i>Motor</i>	<i>Continuous Output Rating</i>	<i>Motor</i>	<i>Continuous Output Rating</i>
β0.4/5000is	0.13 KW	β2/4000HVis	0.8 KW
β0.5/6000is	0.2 KW	β4/4000HVis	1.2 KW
β1/6000is	0.4 KW	β8/3000HVis	1.9 KW
β2/4000is	0.5 KW	β12/3000HVis	2.8 KW
β4/4000is	0.75 KW	β22/2000HVis	3.9 KW
β8/3000is	1.2 KW		
β12/3000is	1.8 KW		
β22/2000is	2.5 KW		

23.6 Incoming DC Power

The β i and β HVi amplifiers require a 24 VDC power supply for amplifier control power. The user must supply this DC power supply.

The information in Table 3-20 below will help you select the appropriate DC power supply for your motion application.

The same external DC power supply can be used to provide power to multiple amplifiers as long as the supply is rated for the sum of power drawn by all of the amplifiers. To daisy chain the amplifiers, add connections between connector CXA19A and CXA19B on adjacent amplifiers (see the connection diagrams for more details). Up to 8 amplifiers can be daisy chained when using 16 AWG wire or up to 6 amplifiers when using 20 AWG wire.

Table 3-20. Amplifier DC Control Power Specifications

<i>Specification</i>	<i>Description</i>
Input voltage	24V DC ($\pm 10\%$)
Power supply rating (per amplifier)	0.9 amps

24 VDC Fuse Locations

The 24 VDC input is fused to protect the amplifier. The fuse labeled FU1 is located on the gray control board that plugs into the front of the amplifier. The diagrams below show the location on this board for each amplifier model. The replacement fuse part number is ZA06B-6073-K250 (Manufacturer: Daito LM32, DC48V, F3.2A).

A spare fuse is included with each β i series amplifier package (IC800BIK020, IC800BIK040, IC800BIHV010 or IC800BIHV020).

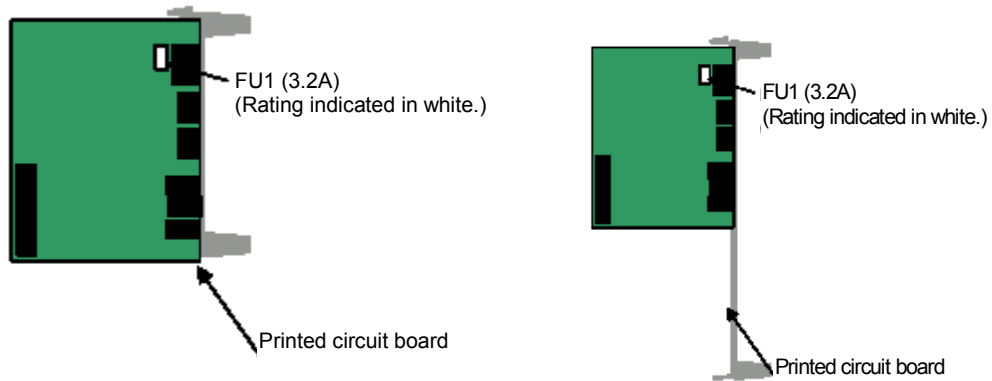

β SVM1-20i Amplifier

β SVM1-40i, β SVM1-10HVi and β SVM1-20HVi Amplifier

23.7 Discharging Regenerative Energy

Regenerative energy is normally created in applications with a high load inertia or frequent acceleration and deceleration. When decelerating a load, the stored kinetic energy of the load causes generator action in the motor causing energy to be returned to the amplifier. For light loads and low acceleration rates, the amplifier may be able to absorb this energy. Otherwise, an optional external regenerative discharge unit must be installed. This optional regeneration capability extends the functionality of the amplifier when working with loads and move profiles that require more capacity than is internal. Calculations shown later in this section can be used to determine the need for an external unit.

If the regenerative discharge unit overheats, a built-in thermostat is tripped, the external overheat alarm is issued, and the motor is stopped. If an external regenerative discharge unit is required, a separate unit must be installed for each amplifier. This component cannot be daisy-chained.

βSVM1-20i Amplifier Regeneration Options

For the βSVM1-20i amplifier, two optional separate 30-Ohm regenerative discharge units are available with power ratings of 100 W and 20 W. The 100 W unit (ZA06B-6130-H402) is panel-mounted, whereas the 20 W unit (ZA06B-6130-H401) mounts to the tapped holes on the side of the amplifier heat sink. The dimensions and connections for both units are shown in the connection section of this document.

NOTE

The amplifiers include an input on connector CXA20 (DCOH) for a normally closed thermal overload switch to protect the external regeneration resistor from overheating. If an external resistor is not used this input must be connected with a wire jumper or the amplifier will generate a fault and will not run.

βSVM1-40i Amplifier Regeneration Options

For this amplifier, two optional regeneration units are available. Both regeneration modules are panel mounted.

<i>Regenerative Resistor Kit</i>	<i>No Fan Cooling</i>	<i>Fan Cooling (2 meters/sec air flow)</i>	<i>Fan Cooling (4 meters/sec air flow)</i>
ZA06B-6089-H500	200 watt	400 watt	600 watt
ZA06B-6089-H713	Incorporates a cooling fan in the kit		800 watt

βSVM1-40i, βSVM1-10HVi, βSVM1-20HVi and βSVM1-40HVi Switch Settings

There are four switches located on the front of the βSVM1-40i, βSVM1-10HVi, βSVM1-20HVi and βSVM1-40HVi series servo amplifiers that configure the amplifier for the regenerative resistor option used. These switches should be set as described below before using these servo amplifiers.

WARNING

If the switch settings are not correct it is possible to damage the regenerative resistor and it will be impossible to normally detect a regenerative overheat alarm.

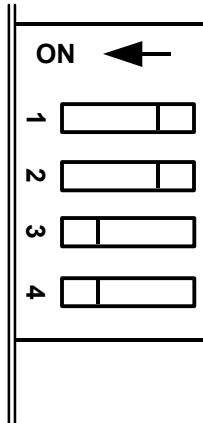

Figure III-26. βSVM1-40i, βSVM1-10HVi, βSVM1-20HVi and βSVM1-40HVi Series Channel Switches

Switch Positions:

The switches are sequentially numbered 1, 2, 3, and 4 with the one at the top as switch 1. The ON position is on the left, and the OFF position is on the right.

Switch 1 Setting: Always set to OFF.

Switch 2 Setting: Always set to OFF.

Switches 3 and 4 Settings: The setting of these switches depends on the regenerative discharge resistance used.

Table III-21. Switch 3 and 4 Settings

	<i>βSVM1-40i</i>		<i>βSVM1-10HVi</i>		<i>βSVM1-20HVi</i>		<i>βSVM1-40HVi</i>	
	SW3	SW4	SW3	SW4	SW3	SW4	SW3	SW4
Regenerative Discharge Unit	SW3	SW4	SW3	SW4	SW3	SW4	SW3	SW4
Built-in (50 W) (Default)	ON	ON	ON	ON	ON	ON	ON	ON
External ZA06B-6089-H500 (200 W)	OFF	ON	N/A	N/A	N/A	N/A	N/A	N/A
External ZA06B-6089-H713 (800 W)	OFF	OFF	N/A	N/A	N/A	N/A	N/A	N/A
External ZA06B-6130-H403 (800W)	N/A	N/A	OFF	OFF	OFF	OFF	OFF	OFF

Regenerative Discharge Unit Dimensions

The separate regenerative discharge units are designed with a rear-mounted heat sink that extends through a hole in the mounting plate. The intent is that the user will construct a control cabinet with an internal air plenum into which the heat sinks for the β SVM1-40i amplifiers and associated regenerative discharge units will be mounted. This design eliminates most of the heat dissipation from these units inside the control cabinet.

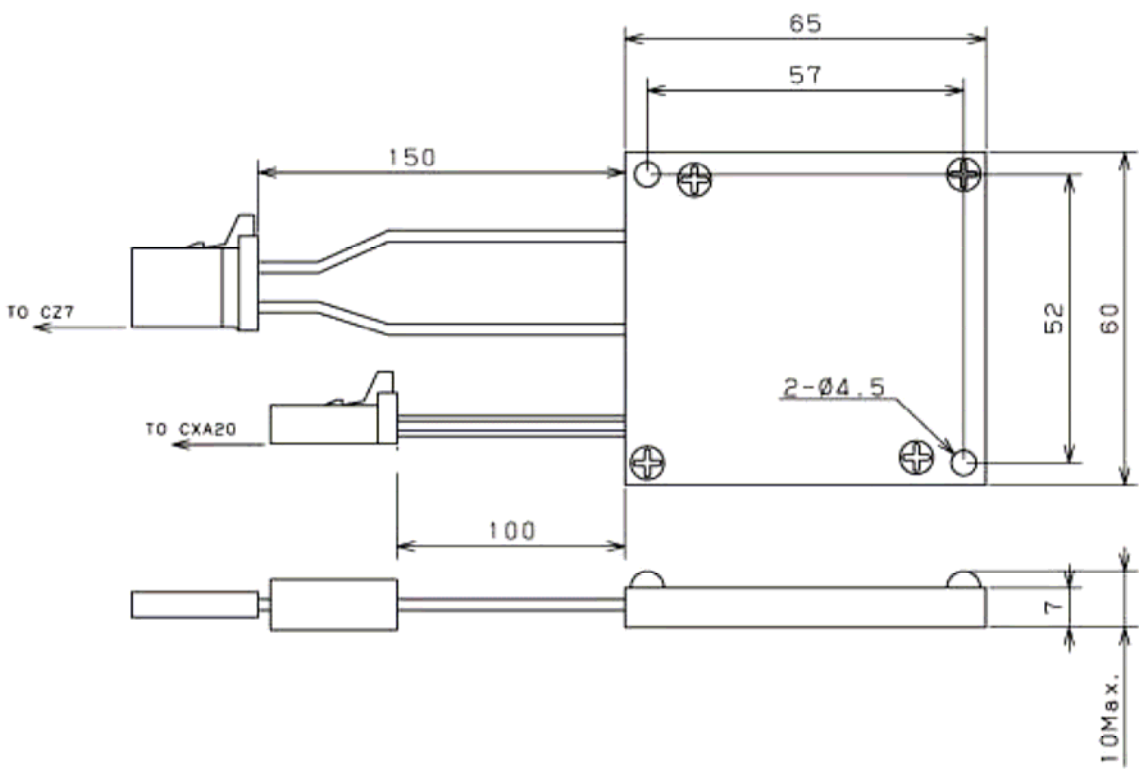

Figure III-27. 20 W Regenerative discharge unit (ZA06B-6130-H401), front and side views

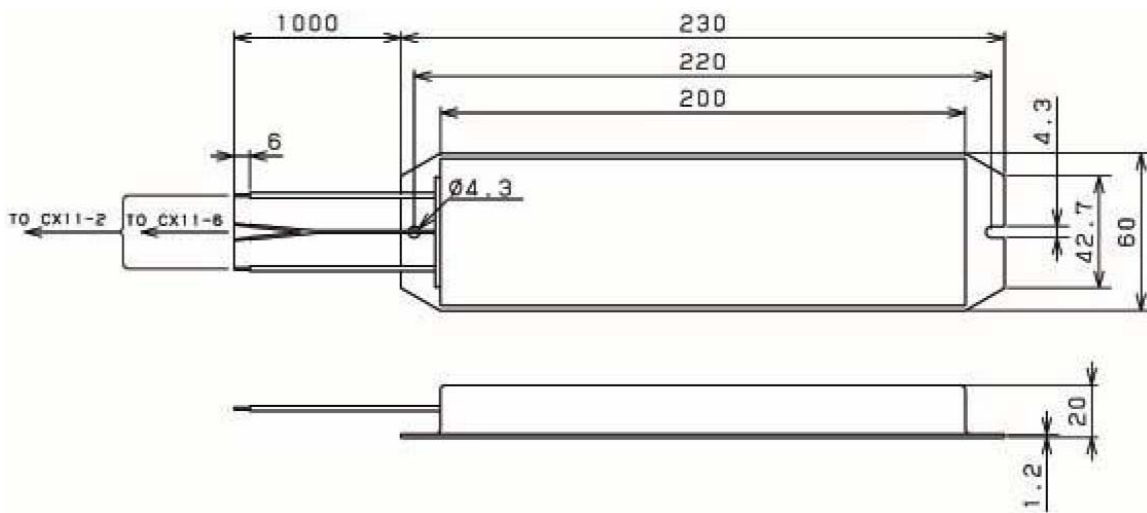

Figure III-28. 100 W Regenerative discharge unit (ZA06B-6130-H402), front and side views

Servo Products Specification Guide

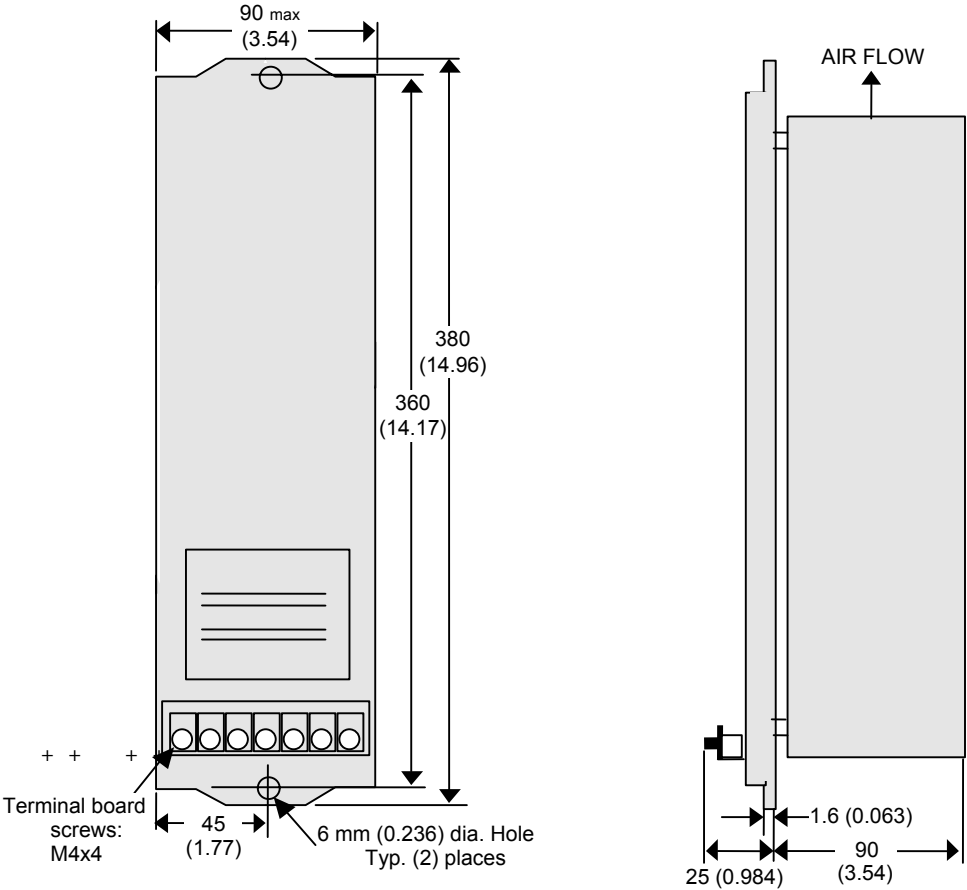

Figure III-29. 200 W Regenerative discharge unit (ZA06B-6089-H500), front and side views

Servo Products Specification Guide

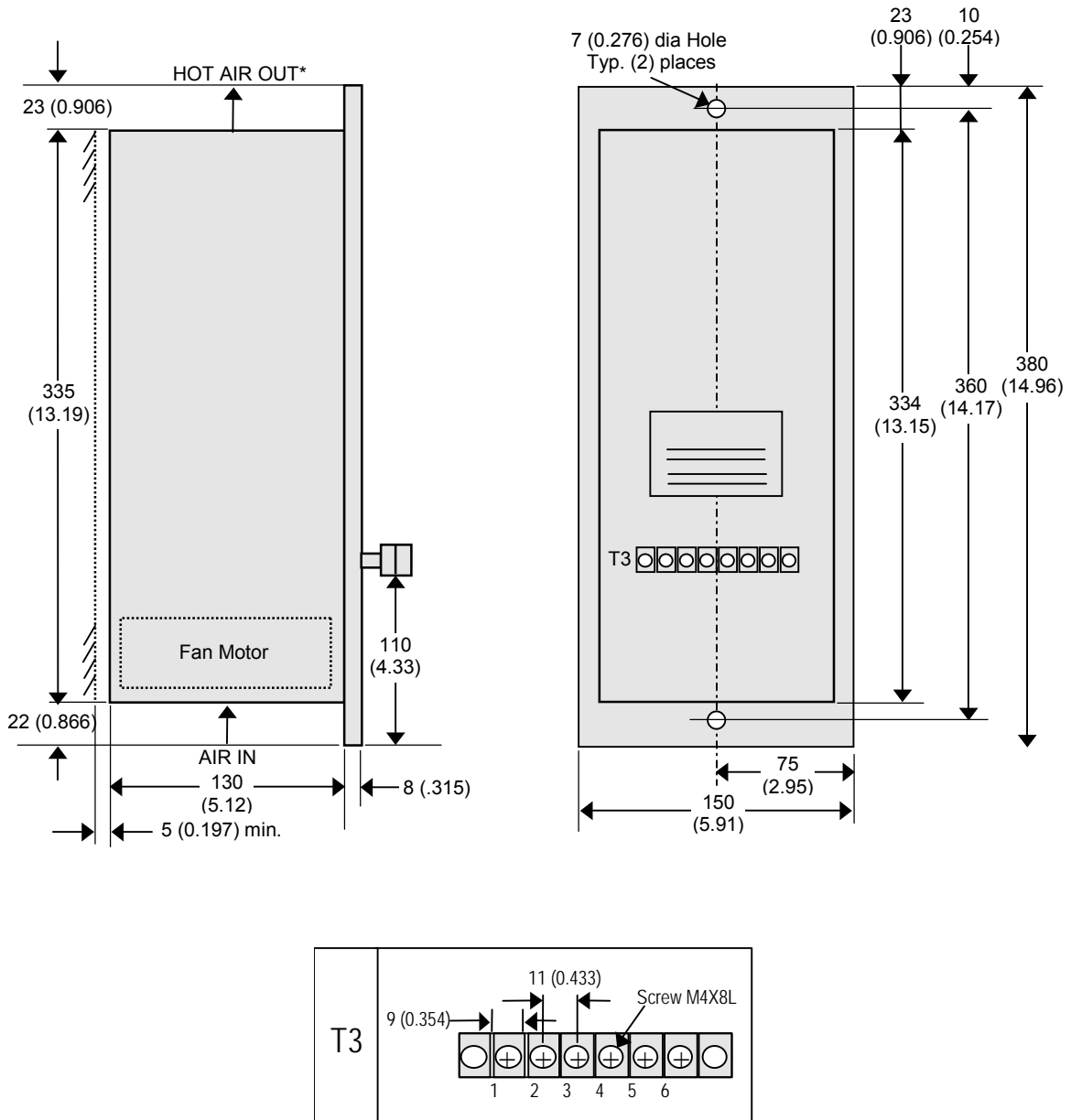

Figure III-30. 800 W Regenerative Discharge Unit (ZA06B-6089-H713), Front, Side, and End Views with T3 Terminal Detail

Servo Products Specification Guide

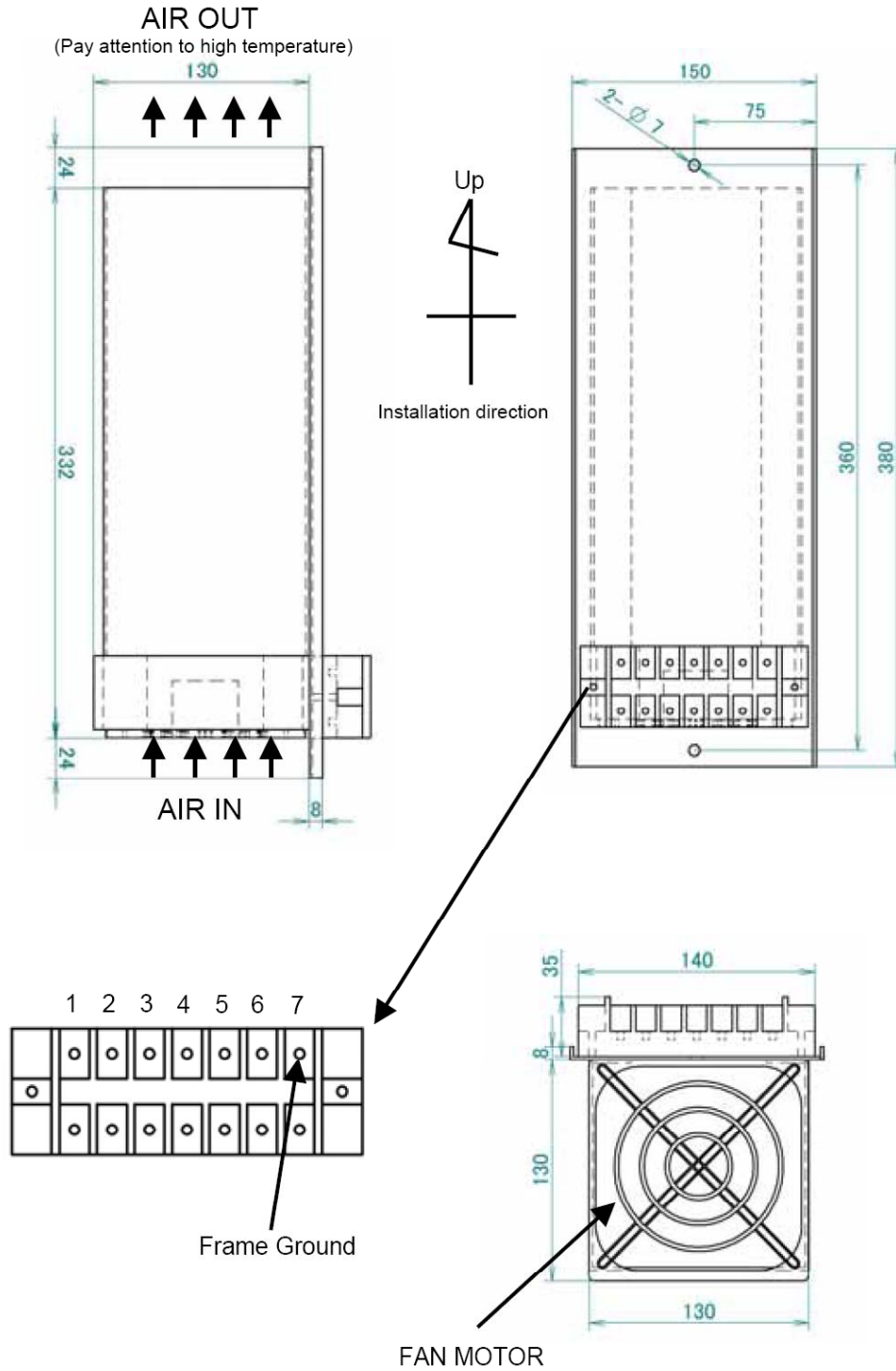
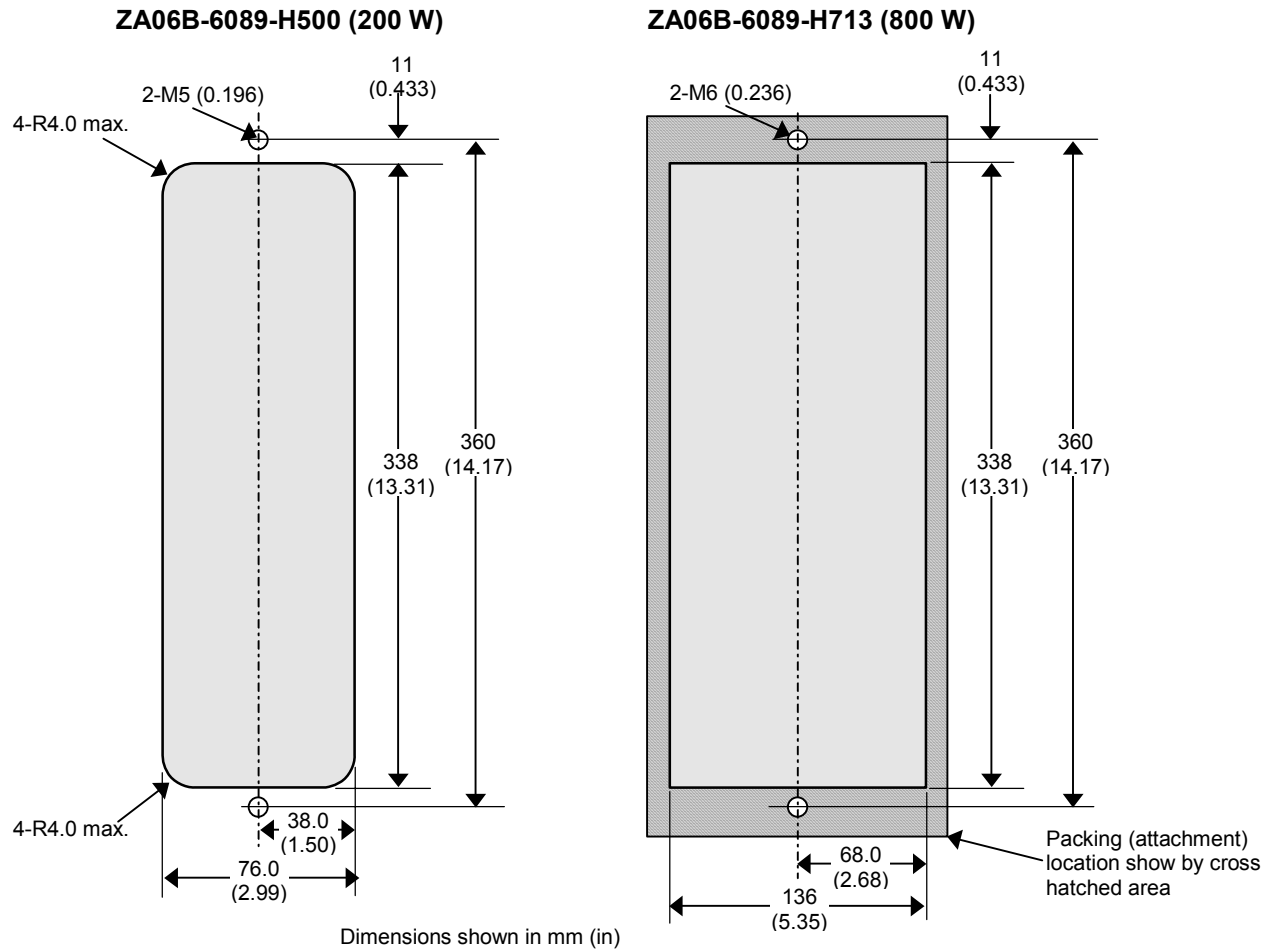

Figure III-31. 800 W Regenerative Discharge Unit (ZA06B-6130-H403), Front, Side, and End Views

Regenerative Discharge Unit Panel Cutout Dimensions

The panel cutouts necessary to mount the separate regenerative discharge units are shown below.



CAUTION:
 Attach packing (acrylonitrile-butadiene rubber or soft NBR) around the cutout to keep out oil and dust.

Figure III-32. Regenerative discharge unit panel cutout dimensions

Calculating the Average Regenerative Energy

Use the following calculation to determine the average regenerative energy that will be released in your application (ambient temperature is assumed not to exceed 55°C). Based on the calculations select either the internal regeneration or optional external regeneration resistor. The wattage rating of the selected resistor must exceed the average calculated regenerative energy from the equation below:

$$\begin{array}{rclcl} \text{Average} & & \text{Rotational Energy to} & & \text{Energy to be} & & \text{(only in vertical axis operation)} \\ \text{Regenerative} & = & \text{be Released during} & - & \text{Consumed Through} & + & \text{Vertical Energy to be Released} \\ \text{Energy (Joules)} & & \text{Deceleration} & & \text{Axis Friction} & & \text{During Downward Motion} \\ & & \text{(STEP 1)} & & \text{(STEP 2)} & & \text{(STEP 3)} \end{array}$$

STEP 1: Rotational Energy to be Released during Deceleration

$$= (6.19 \times 10^{-4}) \times (J_m + J_L) \times \omega_m^2 \text{ Joules}$$

where:

J_m	Motor rotor inertia	(lb-in-s ²)
J_L	Load inertia converted to motor shaft inertia	(lb-in-s ²)
ω_m	Maximum motor speed at time of deceleration	(rpm)

STEP 2: Energy to be consumed through Axis Friction

$$= (5.91 \times 10^{-3}) \times t_a \times \omega_m \times T_L \text{ where:}$$

ω_m	Motor speed during rapid traverse	(rpm)
t_a	Acceleration/deceleration duration during rapid traverse	(sec)
T_L	Axis friction torque (converted to motor shaft torque)	(lb-in)

STEP 3: Vertical Energy to be Released During Downward Motion

(This term applies only in vertical axis operation)

$$= (1.182 \times 10^{-2}) \times T_h \times \omega_m \times \frac{D}{100} \text{ where:}$$

T_h	Upward supporting torque applied by the motor during downward rapid traverse	(lb-in)
ω_m	Motor speed during rapid traverse	(rpm)
D	Duty cycle of downward vertical operation during rapid traverse	(%)

(Note: the maximum value of D is 50%. D assumes a smaller value)

STEP 4: Determine if a Regenerative Discharge Unit Is Required

Determine the Average Regenerative Energy using the equation in the beginning of this section.

When the average regenerative energy produced never exceeds the amounts indicated in the table below, a separate regenerative discharge unit is **not** required:

Servo Products Specification Guide

Table 3-22. Maximum Allowable Regenerative Power for Amplifiers

<i>Amplifier</i>	<i>Max. Allowable Regen. Energy</i>
βSVM1-20i	16 Joules
βSVM1-40i	50 Watts
βSVM1-10HVi	50 Watts
βSVM1-20HVi	50 Watts
βSVM1-40HVi	50 Watts

If the calculated value exceeds the storage capability of the amplifier, then an external regenerative discharge unit is required (see Step 5).

STEP 5: Selecting a Regenerative Discharge Unit

If a separate regenerative discharge unit is required, the following calculation will determine the unit required:

$$\text{Average Regenerative Power (W)} = \text{Average Regenerative Energy (Joules)} \times \frac{1}{F} \text{ where:}$$

F = Deceleration duty (seconds) Example: deceleration once per 5 second cycle, F=5

Select a regenerative resistor with a rating that exceeds the average regenerative power.

Example:

Assume a horizontal axis using a β2/4000i motor ($J_m = 0.0002146 \text{ lb-in-s}^2$) that decelerates once every 6 seconds (F) for 0.2 seconds (t_a) with a maximum speed of 2000 RPM (ω_m). The machine inertia (J_L) is $0.00139 \text{ lb-in-s}^2$.

STEP 1: Rotational Energy = $(6.19 \times 10^{-4}) \times (0.0002146 + 0.00139) \times 2000^2 = 3.97 \text{ Joules}$

STEP 2: Assuming $T_L = 10 \text{ in-lb}$:

$$\text{Friction Energy} = (5.91 \times 10^{-3}) \times 0.2 \times 2000 \times 10 = 23.64 \text{ Joules}$$

Therefore:

STEP 4: Average Regenerative Energy = $3.97 - 23.64 = 27.61 \text{ Joules}$

Because the 27.61 Joules required is more than the 16 Joules allowed by the βSVM1-20i amplifier used with the β2i motor, an external regenerative resistor is required.

STEP 5: Since the application requires decelerations every 6 seconds, $\frac{1}{F} = \frac{1}{6}$

$$\text{Average Regenerative Power} = 27.61 \text{ Joules} / 6 \text{ seconds} = 4.6 \text{ W}$$

Therefore, the 20 W resistor (ZA06B-6130-H401) is adequate for this application.

Section 24: β i and β HVi Series Servo System Connection

When planning your motion control system, it is important to determine how the different parts of the system connect together. This section provides information on the various cables and connectors required to connect the motor, amplifier and motion controller.

Many cables required for the system are available from GE Intelligent Platforms. Motor cable and connector kit part numbers for each motor and amplifier combination are shown in the table below.

Table 3-23. β 0.4is to β 2is Motor Power, Feedback and Brake Cables and Connector Kits

<i>Motor Model</i>		<i>β0.4/5000is</i>	<i>β0.5/6000is</i>	<i>β1/6000is</i>	<i>β2/4000is</i>
<i>Amplifier Model</i>		<i>βSVM1-20i</i>	<i>βSVM1-20i</i>	<i>βSVM1-20i</i>	<i>βSVM1-20i</i>
Power Cable	7 M	CP8B-1WPB-0070-AZ	CP8B-1WPB-0070-AZ	CP8B-1WPB-0070-AZ	CP9B-0WPB-0070-AZ
	14 M	CP8B-1WPB-0140-AZ	CP8B-1WPB-0140-AZ	CP8B-1WPB-0140-AZ	CP9B-0WPB-0140-AZ
Power Cable (Shielded)	7 M	CP8B-1WEB-0070-AZ	CP8B-1WEB-0070-AZ	CP8B-1WEB-0070-AZ	CP9B-0WEB-0070-AZ
	14 M	CP8B-1WEB-0140-AZ	CP8B-1WEB-0140-AZ	CP8B-1WEB-0140-AZ	CP9B-0WEB-0140-AZ
Feedback Cable (Right Angle)	7 M	CFDA-7WPB-0070-AZ	CFDA-7WPB-0070-AZ	CFDA-7WPB-0070-AZ	CFDA-7WPB-0070-AZ
	14 M	CFDA-7WPB-0140-AZ	CFDA-7WPB-0140-AZ	CFDA-7WPB-0140-AZ	CFDA-7WPB-0140-AZ
Feedback Cable (Straight)	7 M	CFDA-0WPB-0070-AZ	CFDA-0WPB-0070-AZ	CFDA-0WPB-0070-AZ	CFDA-0WPB-0070-AZ
	14 M	CFDA-0WPB-0140-AZ	CFDA-0WPB-0140-AZ	CFDA-0WPB-0140-AZ	CFDA-0WPB-0140-AZ
Brake Power Cable	7 M	CB6N-5WPM-0070-AZ	CB6N-5WPM-0070-AZ	CB6N-5WPM-0070-AZ	Integrated with Power Cable
	14 M	CB6N-5WPM-0140-AZ	CB6N-5WPM-0140-AZ	CB6N-5WPM-0140-AZ	Integrated with Power Cable
Motor Feedback Connector Kit	90 Deg	ZA06B-6114-K204#E	ZA06B-6114-K204#E	ZA06B-6114-K204#E	ZA06B-6114-K204#E
	Straight	ZA06B-6114-K204#S	ZA06B-6114-K204#S	ZA06B-6114-K204#S	ZA06B-6114-K204#S
Motor Power/Brake Connector Kit	90 Deg	N/A	N/A	N/A	ZA06B-6114-K220#E
	Straight	N/A	N/A	N/A	ZA06B-6114-K220#S
Motor Power Connector Kit	90 Deg	ZA06B-6114-K230#E	ZA06B-6114-K230#E	ZA06B-6114-K230#E	N/A
	Straight	ZA06B-6114-K230#S	ZA06B-6114-K230#S	ZA06B-6114-K230#S	N/A
Motor Brake Connector Kit	90 Deg	ZA06B-6114-K232#E	ZA06B-6114-K232#E	ZA06B-6114-K232#E	N/A
	Straight	ZA06B-6114-K232#S	ZA06B-6114-K232#S	ZA06B-6114-K232#S	N/A

Servo Products Specification Guide

Table 3-24. β 4is to β 22is Motor Power, Feedback and Brake Cables and Connector Kits

<i>Motor Model</i>		<i>β4/4000is</i>	<i>β8/3000is</i>	<i>β12/3000is</i>	<i>β22/2000is</i>
<i>Amplifier Model</i>		<i>βSVM1-20i</i>	<i>βSVM1-20i</i>	<i>βSVM1-40i</i>	<i>βSVM1-40i</i>
Power Cable	7 M	CP9B-0WPB-0070-AZ	CP3B-0WPB-0070-AZ	CP5B-0WPB-0070-AZ	CP6B-0WPB-0070-AZ
	14 M	CP9B-0WPB-0140-AZ	CP3B-0WPB-0140-AZ	CP5B-0WPB-0140-AZ	CP6B-0WPB-0140-AZ
Power Cable (Shielded)	7 M	CP9B-0WEB-0070-AZ	CP3B-0WEB-0070-AZ	CP5B-0WEB-0070-AZ	CP6B-0WEB-0070-AZ
	14 M	CP9B-0WEB-0140-AZ	CP3B-0WEB-0140-AZ	CP5B-0WEB-0140-AZ	CP6B-0WEB-0140-AZ
Feedback Cable (Right Angle)	7 M	CFDA-7WPB-0070-AZ	CFDA-7WPB-0070-AZ	CFDA-7WPB-0070-AZ	CFDA-7WPB-0070-AZ
	14 M	CFDA-7WPB-0140-AZ	CFDA-7WPB-0140-AZ	CFDA-7WPB-0140-AZ	CFDA-7WPB-0140-AZ
Feedback Cable (Straight)	7 M	CFDA-0WPB-0070-AZ	CFDA-0WPB-0070-AZ	CFDA-0WPB-0070-AZ	CFDA-0WPB-0070-AZ
	14 M	CFDA-0WPB-0140-AZ	CFDA-0WPB-0140-AZ	CFDA-0WPB-0140-AZ	CFDA-0WPB-0140-AZ
Holding Brake Power Cable	7 M	Integrated with Power Cable	CB4N-0WPM-0070-AZ	CB4N-0WPM-0070-AZ	CB4N-0WPM-0070-AZ
	14 M	Integrated with Power Cable	CB4N-0WPM-0140-AZ	CB4N-0WPM-0140-AZ	CB4N-0WPM-0140-AZ
Motor Feedback Connector Kit	90 Deg	ZA06B-6114-K204#E	ZA06B-6114-K204#E	ZA06B-6114-K204#E	ZA06B-6114-K204#E
	Straight	ZA06B-6114-K204#S	ZA06B-6114-K204#S	ZA06B-6114-K204#S	ZA06B-6114-K204#S
Motor Power/Brake Connector Kit	90 Deg	ZA06B-6114-K220#E	N/A	N/A	N/A
	Straight	ZA06B-6114-K220#S	N/A	N/A	N/A
Motor Power Connector Kit	90 Deg	N/A	ZA06B-6079-K812	ZA06B-6079-K812	ZA06B-6079-K815
	Straight	N/A	ZA06B-6079-K811	ZA06B-6079-K811	ZA06B-6079-K814
Motor Brake Connector Kit	90 Deg	N/A	ZA06B-6114-K213#E	ZA06B-6114-K213#E	ZA06B-6114-K213#E
	Straight	N/A	ZA06B-6114-K213#S	ZA06B-6114-K213#S	ZA06B-6114-K213#S

Table 3-25. β 2HVis and β 4HVis Motor Power, Feedback and Brake Cables and Connector Kits

<i>Motor Model</i>		<i>β2/4000HVis</i>	<i>β4/4000HVis</i>
<i>Amplifier Model</i>		<i>βSVM1-10HVI</i>	<i>βSVM1-10HVI</i>
Power Cable	7 M	CP2I-0WPB-0070-AZ	CP2I-0WPB-0070-AZ
	14 M	CP2I-0WPB-0140-AZ	CP2I-0WPB-0140-AZ
Power Cable (Shielded)	7 M	CP2I-0WEB-0070-AZ	CP2I-0WEB-0070-AZ
	14 M	CP2I-0WEB-0140-AZ	CP2I-0WEB-0140-AZ
Feedback Cable (Right Angle)	7 M	CFDA-7WPB-0070-AZ	CFDA-7WPB-0070-AZ
	14 M	CFDA-7WPB-0140-AZ	CFDA-7WPB-0140-AZ
Feedback Cable (Straight)	7 M	CFDA-0WPB-0070-AZ	CFDA-0WPB-0070-AZ
	14 M	CFDA-0WPB-0140-AZ	CFDA-0WPB-0140-AZ
Brake Power Cable	7 M	Integrated with Power Cable	Integrated with Power Cable
	14 M		
Motor Feedback Connector Kit	90 Deg	ZA06B-6114-K204#E	ZA06B-6114-K204#E
	Straight	ZA06B-6114-K204#S	ZA06B-6114-K204#S
Motor Power/Brake Connector Kit	90 Deg	ZA06B-6114-K220#E	ZA06B-6114-K220#E
	Straight	ZA06B-6114-K220#S	ZA06B-6114-K220#S
Motor Power Connector Kit	90 Deg	N/A	N/A
	Straight	N/A	N/A
Motor Brake Connector Kit	90 Deg	N/A	N/A
	Straight	N/A	N/A

Servo Products Specification Guide

Table 3-26. β 8HVis to β 22HVis Motor Power, Feedback and Brake Cables and Connector Kits

<i>Motor Model</i>		<i>β8/3000HVis</i>	<i>β12/3000HVis</i>	<i>β22/2000HVis</i>
<i>Amplifier Model</i>		<i>βSVM1-10HVi</i>	<i>βSVM1-20HVi</i>	<i>βSVM1-20HVi</i>
Power Cable	7 M	CP3I-0WPB-0070-AZ	CP3I-0WPB-0070-AZ	CP4I-0WPB-0070-AZ
	14 M	CP3I-0WPB-0140-AZ	CP3I-0WPB-0140-AZ	CP4I-0WPB-0140-AZ
Power Cable (Shielded)	7 M	CP3I-0WEB-0070-AZ	CP3I-0WEB-0070-AZ	CP4I-0WEB-0070-AZ
	14 M	CP3I-0WEB-0140-AZ	CP3I-0WEB-0140-AZ	CP4I-0WEB-0140-AZ
Feedback Cable (Right Angle)	7 M	CFDA-3WPB-0070-AZ	CFDA-3WPB-0070-AZ	CFDA-3WPB-0070-AZ
	14 M	CFDA-3WPB-0140-AZ	CFDA-3WPB-0140-AZ	CFDA-3WPB-0140-AZ
Feedback Cable (Straight)	7 M	CFDA-0WPB-0070-AZ	CFDA-0WPB-0070-AZ	CFDA-0WPB-0070-AZ
	14 M	CFDA-0WPB-0140-AZ	CFDA-0WPB-0140-AZ	CFDA-0WPB-0140-AZ
Brake Power Cable	7 M	CB4N-0WPM-0070-AZ	CB4N-0WPM-0070-AZ	CB4N-0WPM-0070-AZ
	14 M	CB4N-0WPM-0140-AZ	CB4N-0WPM-0140-AZ	CB4N-0WPM-0140-AZ
Motor Feedback Connector Kit	90 Deg	ZA06B-6114-K204#E	ZA06B-6114-K204#E	ZA06B-6114-K204#E
	Straight	ZA06B-6114-K204#S	ZA06B-6114-K204#S	ZA06B-6114-K204#S
Motor Power/Brake Connector Kit	90 Deg	N/A	N/A	N/A
	Straight	N/A	N/A	N/A
Motor Power Connector Kit	90 Deg	ZA06B-6079-K812	ZA06B-6079-K812	ZA06B-6079-K815
	Straight	ZA06B-6079-K811	ZA06B-6079-K811	ZA06B-6079-K814
Motor Brake Connector Kit	90 Deg	ZA06B-6114-K213#E	ZA06B-6114-K213#E	ZA06B-6114-K213#E
	Straight	ZA06B-6114-K213#S	ZA06B-6114-K213#S	ZA06B-6114-K213#S

24.1 Connectors on the Motor Side

For the FANUC AC Servo Motor β is series, a TÜV-approved connector is used as the power line connector to meet the IEC60034 standard.

- The power connector for β 0.2is and β 0.3is is not drip proof.
- The power connectors for β 0.4is to β 4is are drip proof when engaged with the cable connector.
- As the power connectors for β 8is to β 22is, receptacle connectors, which are drip proof by themselves (when not engaged), are used as standard. The power connectors for β 8is and β 22is are compatible with MS standard round connectors, though they do not strictly conform to the MS standard.
- The signal connector for β 0.2is and β 0.3is is not drip proof.
- The signal connector for β 0.4is to β 22is is drip proof when engaged with the cable connector. (When the motor cable is not connected, the connector is drip proof when the protective cap mounted to the connector at shipment is installed.)

Servo Products Specification Guide

Table 3-27. Connectors for $\beta 0.2$ is and $\beta 0.3$ is

<i>Motor Type</i>	<i>For Power</i>	<i>For Signal</i>	<i>For Brake</i>
$\beta 0.2/5000$ is	3-179554-3	1-1318115-6	Common to connector for power
$\beta 0.3/5000$ is	(Tyco Electronics AMP)	(Tyco Electronics AMP)	

Table 3-28. Connectors for $\beta 0.4$ iS to $\beta 1$ iS

<i>Motor Type</i>	<i>For Power</i>	<i>For Signal</i>	<i>For Brake</i>
$\beta 0.4/5000$ is $\beta 0.5/5000$ is $\beta 1/5000$ is	55618-0401 (MOLEX JAPAN Co., Ltd.)	JN2AS10UL1 (Japan Aviation Electronics Industry)	55619-0401 (MOLEX JAPAN Co., Ltd.)

Table 3-29. Connectors for $\beta 2$ iS, $\beta 2$ HVis, $\beta 4$ iS and $\beta 4$ HVis

<i>Motor Type</i>	<i>For Power</i>	<i>For Signal</i>	<i>For Brake</i>
$\beta 2/4000$ is $\beta 4/4000$ is	1473060-2 (Tyco Electronics AMP)	JN2AS10UL1 (Japan Aviation Electronics Industry)	Included in the power line connector.

Table 3-30. Connectors for $\beta 8$ iS, $\beta 8$ HVis, $\beta 12$ iS and $\beta 12$ HVis

<i>Motor Type</i>	<i>For Power</i>	<i>For Signal</i>	<i>For Brake</i>
$\beta 8/3000$ is $\beta 12/3000$ is	H/MS3102A18-10P-D-T(10) (Hirose Electric)	JN2AS10UL1 (Japan Aviation Electronics Industry)	JN2AS04MK2 (Japan Aviation Electronics Industry)

Table III-31. Connectors for $\beta 22$ iS and $\beta 22$ HVis

<i>Motor Type</i>	<i>For Power</i>	<i>For Signal</i>	<i>For Brake</i>
$\beta 22/2000$ is	JL04HV-2E22-22PE-BT	JN2AS10UL1	JN2AS04MK2
	(Japan Aviation Electronics Industry)	(Japan Aviation Electronics Industry)	(Japan Aviation Electronics Industry)

CAUTION

1. The motors should be installed with their connector facing downward, if possible. When it is impossible to install a motor in this position, allow slack in the cable to keep liquids such as a dielectric fluid from going along the cable into the cable or motor. If there is a possibility that the motors and connectors will get wet, provide a cover to protect them.
2. If a motor is not connected to the earth ground through the machine (frame), connect the motor grounding point and the amplifier grounding point to absorb noise using a 1.25 mm² or larger conductor other than the grounding conductor in the power cable. Keep the grounding conductor as far from the power cable as possible.

24.2 Signal Connectors on the Cable Side (Models $\beta 0.2is$ and $\beta 0.3is$)

The signal connector on the cable side for $\beta 0.2is$ and $\beta 0.3is$ is not drip proof. To connect the cable, a dedicated crimping tool must be used. Consider crimping, cable clamp, and voltage drop. Also note that there are restrictions.

	<i>For Signal</i>		
Housing specification (Tyco Electronics AMP)	1-1318118-6 (D-2100D 12-position receptacle housing)		
Contact specifications (Tyco Electronics AMP)	1318107-1 (D-2 receptacle contact M)		1318108-1 (D-2 receptacle contact S)
Applicable wire size	0.18 to 0.5 mm ²	0.3 to 0.85 mm ²	0.08 to 0.2 mm ²
Insulation external diameter	φ0.88 to 1.5 mm	φ1.1 to 1.87 mm	φ0.88 to 1.5 mm
Applicable crimping tool	1463475-1 (Dedicated crimping tool)	1276654-1 (D-2 M standard tool)	1276653-1 (D-2 S standard tool)

The following signal connector kit is available:

	<i>For signal</i>
Connector kit specification (FANUC specification)	A06B-6114-K241
Contents of the connector kit	Receptacle housing (1-1318118-6)×1 Receptacle contact D-2 M (1318107-1)×12

The following dedicated tools are required for this connector.

	<i>Applicable contact</i>	<i>Tyco Electronics AMP specification</i>	<i>FANUC specification</i>
Crimping tool	D-2 contact size M (Dedicated crimping tool for wire size 0.18 to 0.5 mm ²)	1463475-1	A06B-6114-K242
	D-2 contact size M	1276654-1	A06B-6110-K220#D2M
	D-2 contact size S	1276653-1	-
Extractor	D-2 contact	1276716-1	A06B-6110-K220#D2R

Notes:

- When you use the recommended wire (cable diameter of 0.18 to 0.5 mm) with a D-2 size M contact, the dedicated crimping tool listed above is required. Use a standard crimping tool for a D-2 contact within the applicable range, checking the size of the wire to be used, contact type, and crimping tool specification.
- The contacts are of the type that crimps the covering in addition to the wire. Follow the dimension of the insulation part listed above. An insulation of a diameter outside the above range may be able to be connected depending on the wire or tool, however. For details, contact the connector manufacturer.

24.3 Signal Connectors on the Cable Side (models $\beta 0.4is$ to $\beta 22is$ and $\beta 2HVis$ to $\beta 22HVis$)

The signal connectors on the cable side for $\beta 0.4is$ to $\beta 22is$ are drip proof when engaged with the motor connector. To connect the cable, a dedicated crimping tool must be used. Consider crimping, cable clamp, and voltage drop. Also note that there are restrictions.

		<i>For signal</i>	
Connector specifications	Straight type	JN2DS10SL1 or JN2DS10SL2: Connector, JN1-22-22S: Contact (Japan Aviation Electronics Industry) A06B-6114-K204#S (FANUC specification) * Including the contact	
	Elbow type	JN2FS10SL1 or JN2FS10SL2: Connector, JN1-22-22S: Contact (Japan Aviation Electronics Industry) A06B-6114-K204#E (FANUC specification) * Including the contact	
Insulation external diameter		$\phi 1.5$ or less	
Compatible cable O.D.		$\phi 5.7$ to $\phi 7.3$: JN2DS10SL1 or JN2FS10SL1 $\phi 6.5$ to $\phi 8.0$: JN2DS10SL2 or JN2FS10SL2 * With the FANUC specifications, two types of bushings: for $\phi 5.7$ to $\phi 7.3$ and for $\phi 6.5$ to $\phi 8.0$ are included.	
Used wire	5V, 0V	Cable length: 28 m or less $0.3 \text{ mm}^2 \times 2$	Cable length: 50 m or less $0.5 \text{ mm}^2 \times 2$ (Strand configuration: 20/0.18 or 104/0.08)
	6V	0.3 mm^2	0.5 mm^2 (Strand configuration: 20/0.18 or 104/0.08)
	RD, *RD	Twisted pair of at least 0.18 mm^2	
Crimping tool	AWG#22 (0.33 mm^2) to AWG#24 (0.2 mm^2) AWG#26 (0.13 mm^2) to AWG#28 (0.08 mm^2)		CT150-2-JN1-B (Japan Aviation Electronics Industry) (conventional specification) A06B-6114-K201#JN1S (FANUC specification)
	AWG#21(0.5 mm^2) AWG#25(0.18 mm^2)		CT150-2-JN1-F (Japan Aviation Electronics Industry) (conventional specification) A06B-6114-K201#JN1L (FANUC specification)
	AWG#22(0.33 mm^2) to AWG#24(0.2 mm^2) AWG#25(0.18 mm^2)		CT150-2-JN1-C (Japan Aviation Electronics Industry) (new specification)
Extractor	ET-JN1(Japan Aviation Electronics Industry) A06B-6114-K201#JN1R (FANUC specification)		

Servo Products Specification Guide

Cable K1 Connectors

The figure below shows the outside dimensions of each type of connector when engaged.

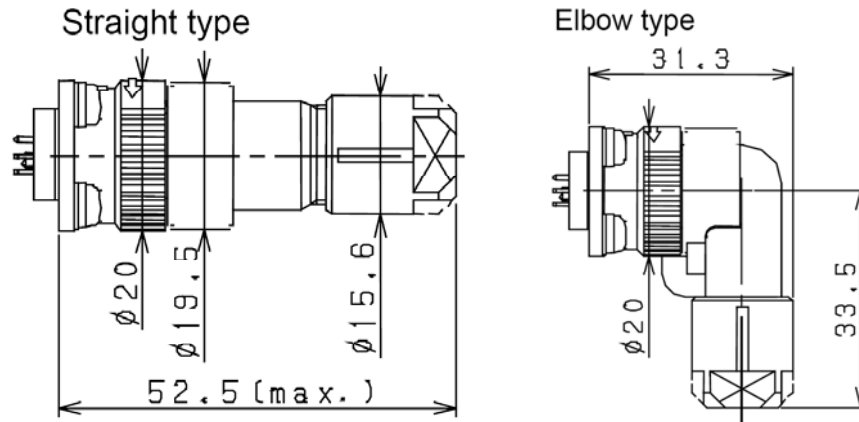

β0.4is to β22is and β2HVis to β22HVis

CAUTION

1. In case that the cable is prepared by MTB, total resistance of 5V and 0V must be less than 2Ω .
2. Encoder side connector can accept maximum 0.5mm^2 (wire construction 20/0.18 or 104/0.08, diameter $\phi 1.5$ or less) wire and sheath diameter is $\phi 5.7$ to $\phi 8.0$. In case of using thicker wire or cable, take measures described below.

[Case 1] Cable conductor exceeds 0.5mm^2 .

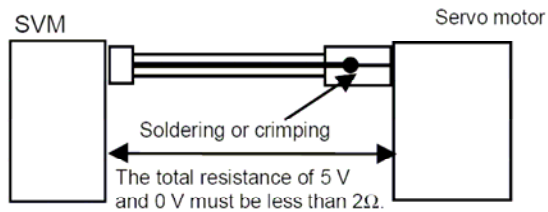

[Case 2] Sheath diameter of exceeds $\phi 8$.

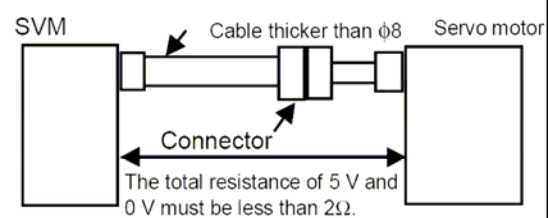

3. If an incremental Encoder is used, it is not necessary to connect 6V.

24.4 Power and Brake Connectors on the Cable Side (models $\beta 0.2is$ and $\beta 0.3is$)

Dedicated connectors which are TÜV approved are available as the connector for power for the $\beta 0.2is$ and $\beta 0.3is$. The following subsection describes the specifications as a connector kit. These connectors are dripproof when engaged. To connect the cable, a dedicated crimping tool must be used. Consider crimping and cable clamp. Also note that there are restrictions.

	<i>For power and brake</i>
Housing specification (Tyco Electronics AMP)	3-178129-6 (D-3200M 6-position receptacle housing XY)
Contact specifications (Tyco Electronics AMP)	1-175218-2 (D-3 receptacle contact L)
Applicable wire size	0.5 to 1.25 mm ²
Insulation external diameter	φ1.8 to 2.8 mm

The following power and brake connector kit is available:

	<i>For power and brake</i>
Connector kit specifications (FANUC specification)	A06B-6114-K240
Contents of the connector kit	Receptacle housing (3-178129-6) × 1 Receptacle contact D-3 L (1-175218-2) × 6

The following dedicated tools are required for this connector.

	<i>Applicable Contact</i>	<i>Tyco Electronics AMP Specification</i>	<i>FANUC Specification</i>
Crimping tool	D-3 contact size L	914596-3	A06B-6110-K220#D3L
Extractor	D-3 contact	234168-1	A06B-6110-K220#D3R

Note: The contacts are of the type that crimps the covering in addition to the wire. Follow the dimension of the insulation part listed above. An insulation of a diameter outside the above range may be able to be connected depending on the wire or tool, however. For details, contact the connector manufacturer.

24.5 Power and Brake Connectors on the Cable Side (models $\beta 0.4is$ to $\beta 1is$)

Dedicated connectors that are TÜV approved are available as the connector for power for the $\beta 0.4is$ to $\beta 1is$. The following subsection describes the specifications as a connector kit. These connectors are drip proof when engaged. To connect the cable, a dedicated crimping tool must be used. Consider crimping and cable clamp. Also note that there are restrictions.

		<i>For power</i>	<i>For brake</i>
Connector body specifications (MOLEX JAPAN Co., Ltd.)	Straight type	54983-0000	54982-0000
	Elbow type	55765-0000	55766-0000

		<i>For power</i>	<i>For brake</i>
Contact specifications (MOLEX JAPAN Co., Ltd.)		56052-8100	
Applicable wire size		0.75 to 1.05 mm ² (AWG18 to AWG17)	
Insulation external diameter		φ2.5 mm or less	
Compatible cable O.D.		φ9.1 to φ9.8 mm	φ6.2 to φ6.7 mm

The following power and brake connector kit is available:

		<i>For power</i>	<i>For brake</i>
Connector kit specification (FANUC specification)	Straight type	A06B-6114-K230#S	A06B-6114-K232#S
	Elbow type	A06B-6114-K230#E	A06B-6114-K232#E
Contents of the connector kit		Connector body × 1 Contact × 4	Connector body × 1 Contact × 3

The following dedicated tools are required for this connector.

	<i>MOLEX JAPAN Co., Ltd</i>	<i>FANUC Specification</i>
Crimping tool	57406-5000	A06B-6114-K234#C
Extractor	57406-6000	A06B-6114-K234#R

Note: The contacts are of the type that crimps the covering in addition to the wire. Follow the dimension of the insulation part listed above. An insulation of a diameter outside the above range may be able to be connected depending on the wire or tool, however. For details, contact the connector manufacturer.

24.6 Power and Brake Connectors on the Cable Side (models β 2is, β 2HVis, β 4is and β 4HVis)

Dedicated connectors that are TÜV approved are available as the connector for power for the β 2is and β 4is. These connectors differ from the conventional α series connectors in connectors and contacts. The following subsection describes the specifications as a connector kit. These connectors are dripproof when engaged. To connect the cable, a dedicated crimping tool must be used. Consider crimping and cable clamp. Also note that there are restrictions.

		<i>For power</i>
Connector kit specifications (Including the contact)	Straight type (standard)	1473063-2 (Tyco Electronics AMP) A06B-6114-K220#S (FANUC specification)
	Elbow type ^(CAUTION 1)	1473393-2 (Tyco Electronics AMP) A06B-6114-K220#E (FANUC specification)
Applicable wire size ^(CAUTION 2)		AWG#18 to 16
Insulation external diameter ^(CAUTION 3)		ϕ 1.8 to 2.8
Compatible cable O.D. ^(CAUTION 4)		ϕ 9.9 to 11.4
Crimping tool ^(CAUTION 5)		91579-1 (Tyco Electronics AMP) A06B-6114-K221#C (FANUC specification)
Extractor ^(CAUTION 5)		1463329-1 (Tyco Electronics AMP) A06B-6114-K221#R (FANUC specification)

CAUTION

1. For the elbow type, a cable juts from the motor in a vertical direction. To connect a conduit hose to the connector, use the elbow type. (The straight type cannot be used due to dimensional restrictions.)
2. The contact is of the crimp type. Be careful of the applicable wire.
3. The crimping contact crimps the covering in addition to the wire. Follow the dimensions listed above. An insulation of a smaller diameter may be able to be connected by a wire or tool, however. For details, contact Tyco Electronics AMP.
4. To satisfy the TÜV-approved and waterproof performance, a cable of an outside diameter within the applicable cable clamp range of ϕ 9.9 to ϕ 11.4 must be used.
5. Dedicated tools are required for crimping and extracting the contact. Keep them on hand when required.

24.7 Power Connectors on the Cable Side (models $\beta 8is$ to $\beta 22is$ and $\beta 8HVis$ to $\beta 22HVis$)

To meet the IEC60034 standard, TÜV-approved plug connectors and cable clamps should be used in connecting the power cable. To meet the IEC60034 standard by using a cable or conduit hose seal adapter, contact the manufacturer for details. FANUC can provide TÜV approved types (waterproof) and waterproof types as plug connectors on the cable side for the FANUC βis series AC servo motors; all these connectors are black. Of course, conventional plug connectors may be used, because they are MS-compatible. The specifications of each connector are explained based on the examples shown below.

Example of connector connection

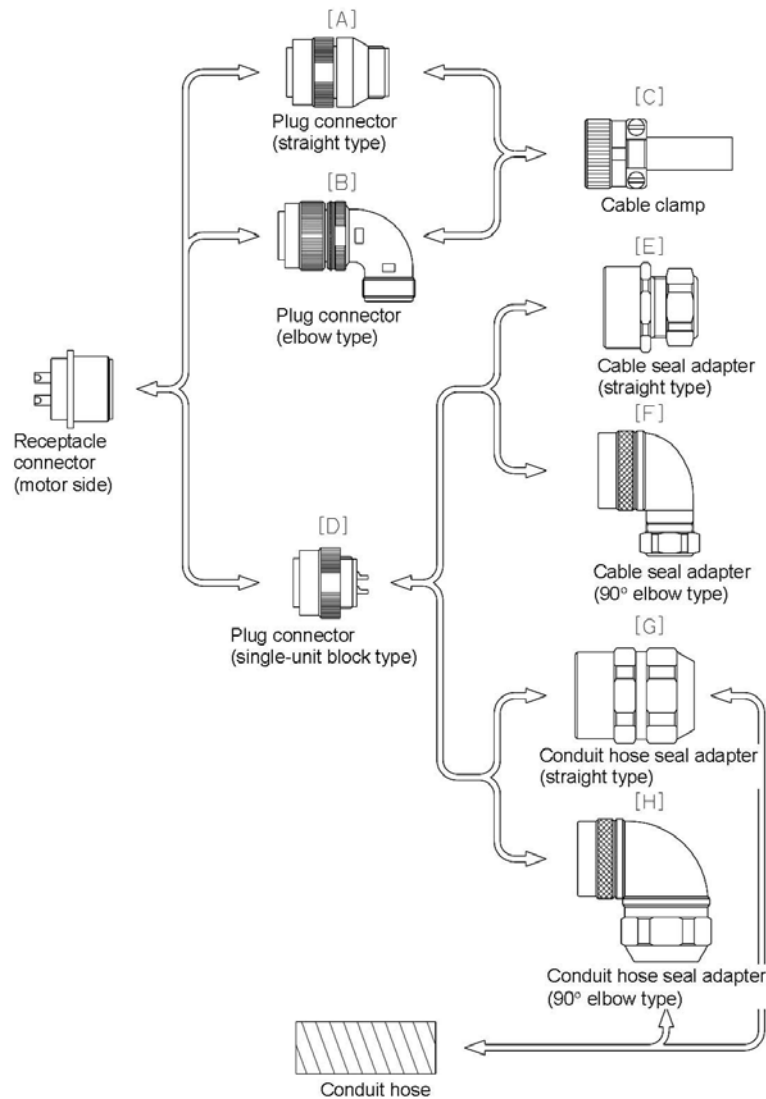

Specifications of plug connectors on the cable side (support for waterproof IP67, TÜV-approved type)

Model Name	[A] Straight Type Plug Connector	[B] Elbow Type Plug Connector	[C] Cable Clamp	[D] Single Block Type Plug Connector
For Power				
β8is β8HVis β12is β12HVis	H/MS3106A18-10S-D-T (10) (Hirose Electric)	H/MS3108A18-10SD-T (10) (Hirose Electric)	H/MS3057-10A (10) (Hirose Electric)	H/MS3106A18-10SD-T (13) (Hirose Electric)
	Solder pot diameter φ2.6	Solder pot diameter φ2.6	Compatible cable O.D. φ10.3 to φ14.3	Solder pot diameter φ2.6
β22is β22HVis	<1> JL04V-6A22-22SE-EB <2> JL04V-6A22-22SE-EB1 (Japan Aviation Electronics Industry)	<1> JL04V-8A22 - 22SE-EB <2> JL04V-8A22 - 22SE-EB1 (Japan Aviation Electronics Industry)	<1> JL04-2022CK (14) <2> JL04-2428CK (20) (Japan Aviation Electronics Industry)	JL04V-6A22-22SE (Japan Aviation Electronics Industry)
	Solder pot diameter φ5.3	Solder pot diameter φ5.3	Compatible cable O.D. <1> φ12.9 to φ16.0 <2> φ18 to φ21	Solder pot diameter φ5.3

- * For the connectors of size 22-22, the part number of the plug connector differs depending on the type of cable clamp.
- * The items preceded by the same number in < > correspond to each other.

CAUTION

TÜV have certified that the plug connectors and cable clamps listed above, when combined with the FANUC AC Servo Motor βis series, satisfy the VDE0627 safety standard. Several manufacturers offer other plug connectors. For information about whether the plug connectors satisfy the safety standard when combined with the FANUC αi series, contact the corresponding manufacturer. Also contact the manufacturers if you require details of their products. For details, see Chapter 4, "CONDITIONS FOR APPROVAL RELATED TO THE IEC60034 STANDARD."

- Hirose Electric (HRS): H/MS310 TÜV-conforming series
- Japan Aviation Electronics Industry (JAE): JL04V series
- DDK Ltd. (DDK): CE05 series

The signal connectors and 24V brake connectors are not subject to the IEC60034 standard.

Servo Products Specification Guide

Specifications of plug connectors on the cable side (support for waterproof IP67)

Model Name	[A] Straight Type Plug Connector	[B] Elbow Type Plug Connector	[C] Cable Clamp	[D] Single Block Type Plug Connector
For Power				
β 8is β 8HVis β 12is β 12HVi	JA06A-18-10S-J1-EB (Japan Aviation Electronics Industry) H/MS3106A1810S(10) (Hirose Electric) MS3106A18-10S-BBSS (DDK Ltd.)	JA08A-18-10S-J1-EB (Japan Aviation Electronics Industry) H/MS3108B18-10S(10) (Hirose Electric) MS3108A18-10S-BBAS (DDK Ltd.)	JL04-18CK(13) (Japan Aviation Electronics Industry) H/MS3057-10A(10) (Hirose Electric) CE3057-10A-1(D265) (DDK Ltd.)	JA06A-18-10S-J1(A72) (Japan Aviation Electronics Industry) H/MS3106A18-10S(13) (Hirose Electric) MS3106A18-10S-B (D190) (DDK Ltd.)
β 22is β 22HVis	JA06A-22-22S-J1-EB (Japan Aviation Electronics Industry) H/MS3106A2222S(10) (Hirose Electric) MS3106A22-22S-BBSS (DDK Ltd.)	JA08A-22-22S-J1-EB (Japan Aviation Electronics Industry) H/MS3108B22-22S(10) (Hirose Electric) MS3108A22-22S-BBAS (DDK Ltd.)	JL04-2022CK-(14) (Japan Aviation Electronics Industry) H/MS3057-12A(10) (Hirose Electric) CE3057-12A-1(D265) (DDK Ltd.)	JA06A-22-22S-J1(A72) (Japan Aviation Electronics Industry) H/MS3106A22-22S(13) Hirose Electric) MS3106A22-22S-B (D190) (DDK Ltd.)

24.8 Brake Connectors on the Cable Side (models $\beta 8is$ to $\beta 22is$ and $\beta 8HVis$ to $\beta 22HVis$)

The models $\beta 8is$ to $\beta 22is$ use a dedicated connector to connect the built-in brake cable. This connector is dripproof. It is connected by soldering, so no special tool is required. Consider soldering, cable clamp, and voltage drop. Also note that there are restrictions.

Specifications of connectors for brake (models $\beta 8is$ to $\beta 22is$)

		<i>For brake</i>
Connector specifications	Straight type	JN2DS04FK2 (Japan Aviation Electronics Industry) A06B-6114-K213#S (FANUC specification)
	Elbow type	JN2FS04FK2 (Japan Aviation Electronics Industry) A06B-6114-K213#E (FANUC specification)
Applicable wire size		AWG#16 or less (1.25mm ² or less) * Solder pot diameter $\phi 1.9$
Insulation external diameter		$\phi 2.7$ or less
Compatible cable O.D.		$\phi 6.5$ to 8.0
Example of applicable wire		300-V two-conductor vinyl heavy-duty power cord cable VCTF (JIS C 3306) or equivalent
Applicable wire size and cable length		0.75mm ² (AWG#18) when cable length 30 m or less 1.25mm ² (AWG#16) when cable length 50 m or less

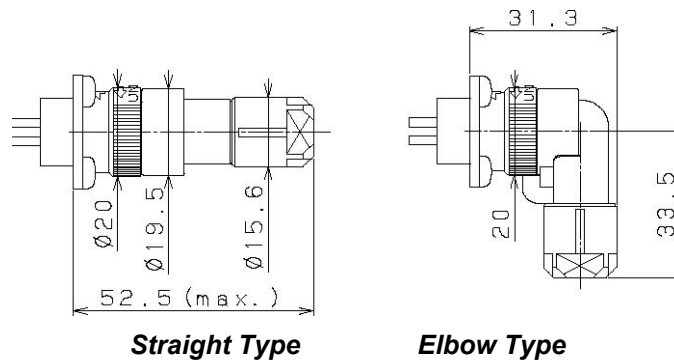

CAUTION

1. The same body is used for the brake and fan connectors. They differ in the key position to prevent an improper insertion.
2. If the cable length is longer than or equal to 50 m, take measures such as installation of repeaters so that the sum of wire resistance (for both ways) becomes 1.5 Ω or less.
3. For details of brakes, see Section 18.4

24.9 Connection to a Conduit Hose

This section gives information on the specifications of several adapters to be connected that are made by conduit hose manufacturers for reference purposes. Before using an adapter, contact the corresponding conduit hose manufacturer.

Specifications of plug connectors on the cable side (Waterproof type/seal adapter specifications)

Model Name	[E] Cable Seal adapter Straight type	[F] Cable Seal adapter Elbow type	[G] Conduit hose Seal adapter Straight type	[H] Conduit hose Seal adapter Elbow type
For power				
β 2is, β 2HVis β 4is, β 4HVis			N2BM20-FN4 (SANKEI) MAS-SG16-M20 (NEOFLEX)	
β 8is, β 8HVis β 12is, β 12HVis	CKD12-18 (SANKEI) YSO 18-12-14 (DAIWA DENGYOU) ACS-12RL-MS18F (NIPPON FLEX) CG12S-JL18 (NEOFLEX)	C90° KD12-18 (SANKEI) YLO 18-12-14 (DAIWA DENGYOU) ACA-12RL-MS18F (NIPPON FLEX) CG12A-JL18 (NEOFLEX)	KKD16-18 (SANKEI) MSA 16-18 (DAIWA DENGYOU) RCC-104RL-MS18F (NIPPON FLEX) MAS16S-JL18 (NEOFLEX)	K90° KD16-18 (SANKEI) MAA 16-18 (DAIWA DENGYOU) RCC-304RL-MS18F (NIPPON FLEX) MAS16A-JL18 (NEOFLEX)
β 22is, β 22HVis	CKD16-22 (SANKEI) YSO 22-12-14 (DAIWA DENGYOU) ACS-16RL-MS22F (NIPPON FLEX) CG16S-JL22 (NEOFLEX)	C90° KD16-22 (SANKEI) YLO 22-12-14 (DAIWA DENGYOU) ACA-16RL-MS22F (NIPPON FLEX) CG16A-JL22 (NEOFLEX)	KKD22-22 (SANKEI) MSA 22-22 (DAIWA DENGYOU) RCC-106RL-MS22F (NIPPON FLEX) MAS22S-JL22 (NEOFLEX)	K90° KD22-22 (SANKEI) MAA 22-22 (DAIWA DENGYOU) RCC-306RL-MS22F (NIPPON FLEX) MAS22A-JL22 (NEOFLEX)
For signal				
Common to all models (other than β 0.2is and β 0.3is)			N2KY16-FN3 (SANKEI) PCJN-12-M13F (DAIWA DENGYOU) RQJN-M13-9 RQJN-M13-16 (NEOFLEX)	
For brake				
Common to all models (other than β 0.2is and β 0.3is)			N2KY16-FN3 (SANKEI) PCJN-12-M13F (DAIWA DENGYOU) RQJN-M13-9 RQJN-M13-16 (NEOFLEX)	

(*) Manufacturers: SANKEI: SANKEI MANUFACTURING CO., LTD.
DAIWA DENGYOU: DAIWA DENGYOU CO., LTD.
NIPPON FLEX: NIPPON FLEX CO., LTD.
NEOFLEX

24.10 Amplifier Connectors

Connector ID	Amplifier	Connector Description	GE Intelligent Platforms Part Number	Supplier	Qty	Supplier Part Number
CZ7	BSVM1-4i BSVM1-20i	Amplifier AC Power Motor Power Regen Resistor	ZA06B-6130-K200	Tyco Electronics AMP	1	Housing: 175363-3
					1	1318095-2
					10	Contact: 175218-2
CZ4	BSVM1-40i BSVM1-80i BSVM1-10HV BSVM1-20HV BSVM1-40HV	Amplifier AC power input	ZA06B-6110-K200#XXS	Tyco Electronics AMP	1	Housing: 1-917807-2
					4	316040-6
CZ5	BSVM1-40i BSVM1-80i BSVM1-10HV BSVM1-20HV BSVM1-40HV	Amplifier Motor Power Connector	ZA06B-6110-K202#YYS	Tyco Electronics AMP	1	Housing: 2-917807-2
					4	Contact: 316040-6
CZ6	BSVM1-40i BSVM1-80i	Regen Resistor	ZA06B-6110-K201#XYM	Tyco Electronics AMP	1	Housing: 3-917807-2
					2	Contact: 316041-6
CXA19A CXA19B	All B i-series Amplifiers	Battery and Estop Signal Daisy-Chain Connector	ZA06B-6130-K201	Tyco Electronics AMP	1	Housing: 1-1318119-3
					6	Contact: 1318107-1
CXA20	All B i-series Amplifiers	Regen Resistor Thermal Protector	ZA06B-6130-K202	Tyco Electronics AMP	1	Housing: 1-318120-3
					4	Contact: 1318107-1
CX29	All B i-series Amplifiers	MCC Relay Contacts Output Connector	ZA06B-6130-K203	Tyco Electronics AMP	1	Housing: 3-1318130-3
					2	Contact: 1318107-1
CX30	All B i-series Amplifiers	Estop Connector	A06B-6130-K204	Tyco Electronics AMP	1	Housing: 3-1318120-3
					2	Contact: 1318107-1

24.11 System Connection Diagram and Cable Reference

Motor and amplifier connector kits required for the system are available from GE Intelligent Platforms. The following figures indicate the physical connector locations on the amplifiers, the appropriate connector designations and connector kit part numbers. The following diagrams illustrate typical system interconnections. For details on cables and connectors, refer to Table III-33.

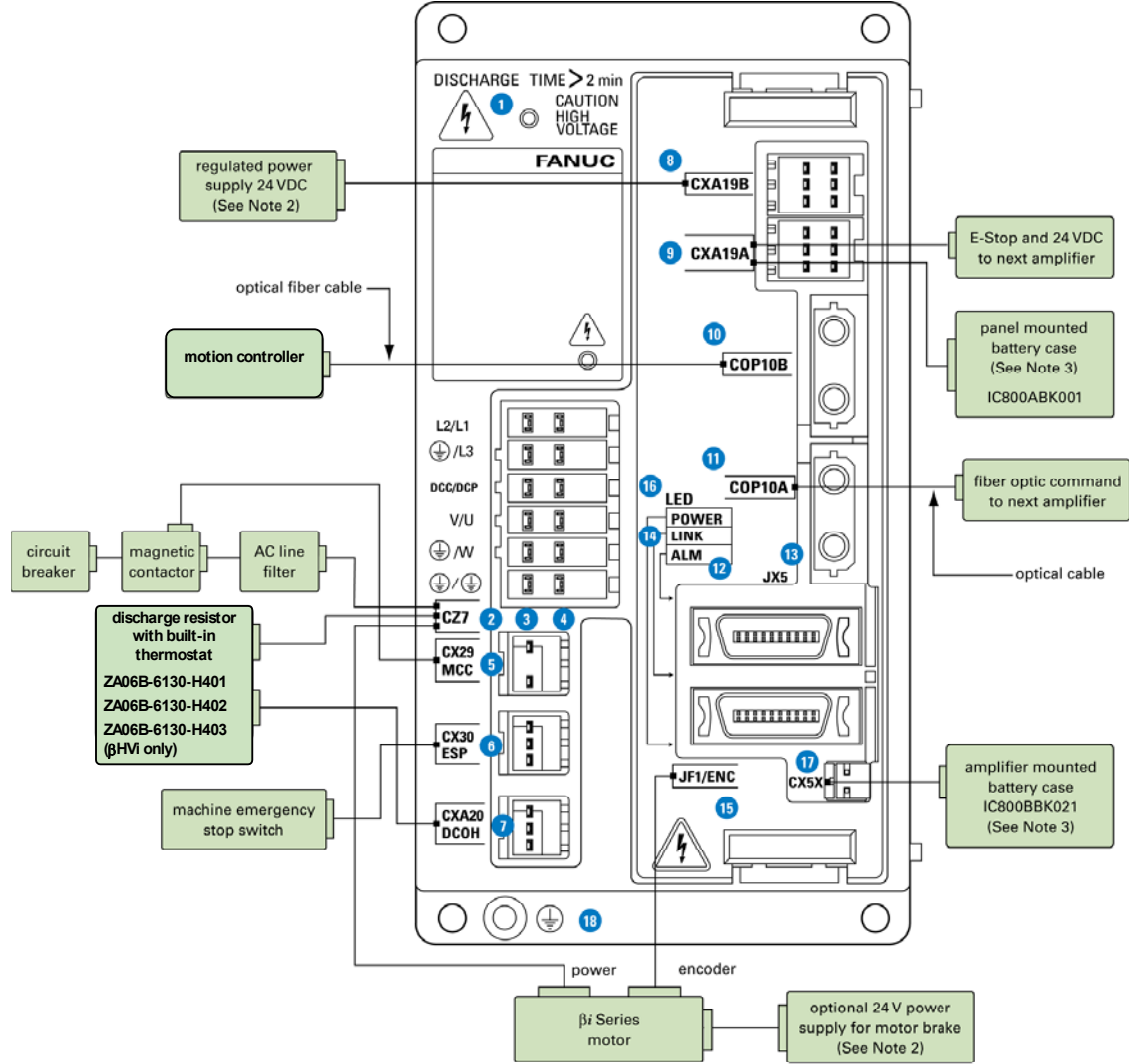

Connector Location

No.	Name	Description	No.	Name	Description	No.	Name	Description
1		DC link charge LED	7	CXA20	Regenerative resistor overtemperature switch connector	13	JX5	Reserved
2	CZ7-1	Main power input connector	8	CXA19B	24 VDC power input	14	LINK	Fiber optic link status LED
3	CZ7-2	Discharge resistor connector	9	CXA19A	24 VDC power input	15	JF1	Serial encoder feedback
4	CZ7-3	Motor power connector	10	COP10B	Fiber optic servo command input	16	POWER	Control power status display LED
5	CX29	Connector for main power MCC control signal	11	COP10A	Fiber optic servo command output	17	CX5X	Absolute encoder battery
6	CX30	E-stop signal connector	12	ALM	Servo alarm status LED	18		Tapped hole for grounding the amplifier

Notes

- 1: Always install the circuit breakers, magnetic contactor, and AC line filter.
- 2: User a regulated 24 VDC power supply for the amplifier. The 24 VDC power supply for the amplifier and power supply for the motor brake cannot be shared.
- 3: The IC800ABK001 encoder battery pack mounts separately on the panel and can power up to four axes. Alternatively, the IC800BBK021 one-axis lithium battery can be snapped onto each amplifier.

Figure III-33. βSVM1- 20i Connection Diagram

Servo Products Specification Guide

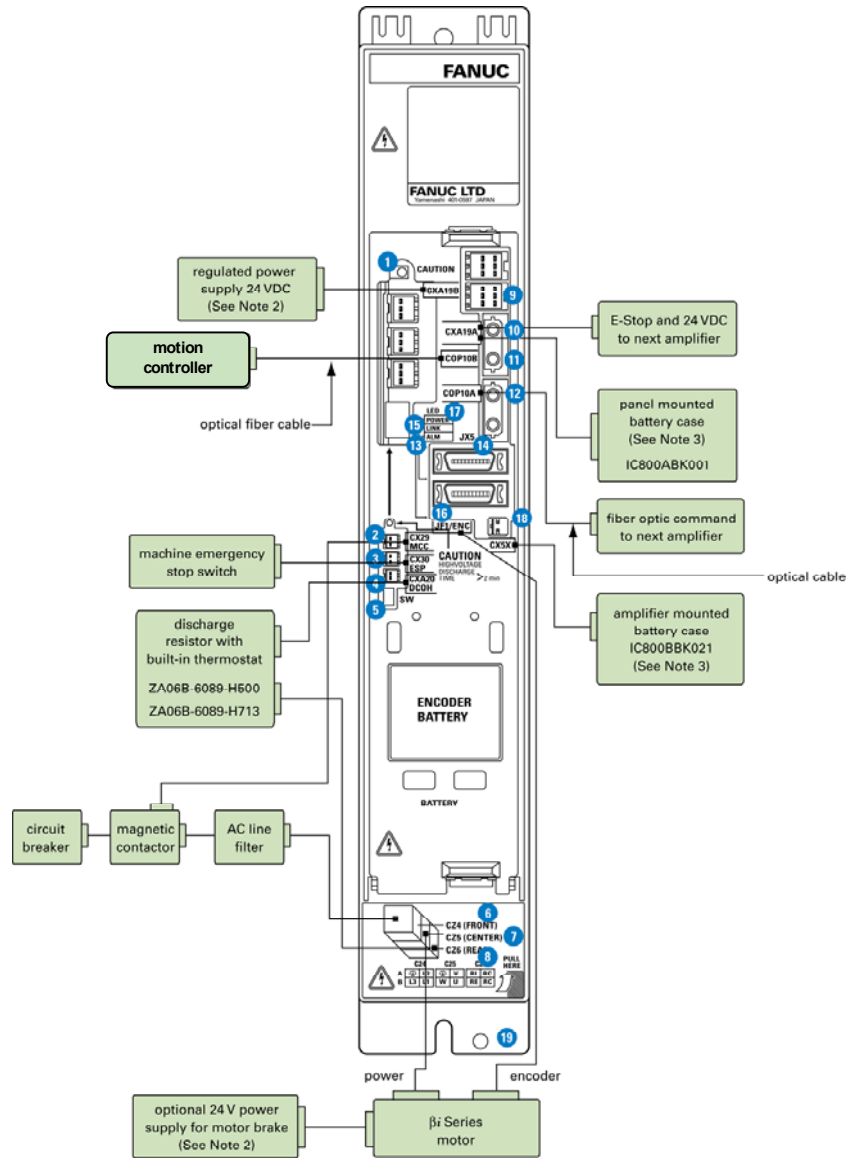



Figure III-34. βSVM1- 40i, βSVM1-10HV, βSVM1-20HV and βSVM1-40HV Connection Diagram

Servo Products Specification Guide

Table 3-32. Connector Location

No.	Name	Description	No.	Name	Description	No.	Name	Description
1		DC link charge LED	7	CZ5	Main power connector	13	ALM	Servo alarm status LED
2	CX29	Main power input connector MCC control signal	8	CZ6	Discharge resistor connector	14	JX5	Reserved
3	CX30	E-stop signal connector	9	CXA19B	24 VDC power input	15	LINK	Fiber optic link status LED
4	CXA20	Regenerative resistor overtemperature switch connector	10	CXA19A	24 VDC power input	16	JF1	Serial encoder feedback
5	SW	Setting switch (DC alarm level)	11	COP10B	Fiber optic servo command input	17	POWER	Control power status display LED
6	CZ4	Main power input connector	12	COP10A	Fiber optic servo command output	18	CX5X	Absolute encoder batter
						19		Tapped hole for grounding the amplifier

Notes

- 1: Always install the circuit breakers, magnetic contactor, and AC line filter.
2. User a regulated 24 VDC power supply for the amplifier. The 24 VDC power supply for the amplifier and power supply for the motor brake cannot be shared.
3. The IC800ABK001 encoder battery pack mounts separately on the panel and can power up to four axes. Alternatively, the IC800BBK021 one-axis lithium battery can be snapped onto each amplifier.

Table III-33. System Connection Cables Summary

Ref.	Connects	GE Intelligent Platforms Cable Part Number	When Required
K1	Built in Serial Motor Encoder to Amplifier (JF1)	See Tables 3-23 and 3-24.	Always.
K2	AC Power to Amplifier	Customer Supplied	Always.
K3	Motor Power to Amplifier	See Tables 3-23 and 3-24.	Always.
K4	Amplifier to Regenerative Discharge Unit	N/A (included with regenerative discharge unit)	In some cases. ¹
K5	Regenerative Discharge Unit Over Temperature Switch to Amplifier	N/A (included with regenerative discharge unit)	In some cases. ¹ (When an external regenerative discharge resistor is not used, a jumper connection must be installed.)
K5	Servo Amplifier Emergency Stop Input (CX30) to Machine E-Stop Contact	Customer Supplied	Always.
K6	Connection of Daisy Chain to an adjacent amplifier the 24 VDC, E-stop and encoder battery backup signals	Customer Supplied	Always.
K7	Relay Output to Control the Main AC Power Contactor Coil (MCC)	Customer Supplied	Control-dependent. Consult your control documentation.
K8	Servo Amplifier Emergency Stop Input (CX30) to Machine E-Stop Contact	Customer Supplied	Always. (When an E-Stop switch is not used a jumper connection must be installed.)
K9	Amplifier (CX19B) to Panel Mounted Backup Battery Holder IC800ABK001	Customer Supplied	One cable per four amplifiers when IC800APK001 encoder battery backup option is used.
K10	External cooling fan to 24VDC power.	This is a factory-installed jumper (T892), since the fan is not required.	Always. (An alarm will be generated if the jumper is not installed.)

¹ See “Discharging Regenerative Energy” on page III-48.

24.12 Cable Details

FSSB Fiber Optic Servo Command Interface Cable

The optical cable is available in various lengths and is used to interface up to four amplifiers to the DSM324i motion controller. Additionally the fiber optic cables come in two styles.

Cable Type	Length	Part Number
PVC Covered Fiber Optic Cable (use in sealed cabinet only)	0.15 meter	ZA66L-6001-0023#L150R0
	0.30 meter	ZA66L-6001-0023#L300R0
	1 meter	ZA66L-6001-0023#L1R003
	2 meter	ZA66L-6001-0023#L2R003
	3 meter	ZA66L-6001-0023#L3R003
Sheathed Fiber Optic Cable*	1 meter	ZA66L-6001-0026#L1R003
	3 meter	ZA66L-6001-0026#L3R003
	5 meter	ZA66L-6001-0026#L5R003
	10 meter	ZA66L-6001-0026#L10R03
	20 meter	ZA66L-6001-0026#L20R03
	30 meter	ZA66L-6001-0026#L30R03
	50 meter	ZA66L-6001-0026#L50R03
100 meter	ZA66L-6001-0026#L100R03	

WARNING

GE Intelligent Platforms cannot guarantee the servo performance and reliability unless the fiber optic command interface cable meets or exceeds the stated specifications.

FSSB Cable Specifications

Connector maker: Tyco Electronics AMP. Parts list:

Connector Part	Vendor Part Number
Ferrule	316892
Housing	316890
Stopper	316891
Spring	900357

- Cable material must be Multi-mode
- Cable loss (max.): 3dB
- The transmission rate is 25Mbps
- The actual fiber used is plastic clad silica fiber
- The core diameter is 200 micrometer, and the plastic clad diameter is 230 micrometer
- The initial loss is 0.015dB per meter (At room temperature)
- The type of light is LED. The wavelength of light is 650nm
- Bend radius minimum: 50mm; Life: ~10 million cycles at 100mm radius, @ +/- 90 degrees
- Twist angle maximum: 360 degrees; Life: 900,000 cycles @ +/- 180 degrees twisting
- Cable must be clamped so that no stretching force is applied and no forces within 200mm (8 inches) of connector.

Servo Products Specification Guide

FSSB Cable Connections

Each β i and β HVi Series amplifier has two FSSB connectors labeled C0P10A and C0P10B. Connector C0P10A is an optical transmitter and C0P10B is an optical receiver. Proper system operation requires that the FSSB cables be installed on the proper connector as shown below.

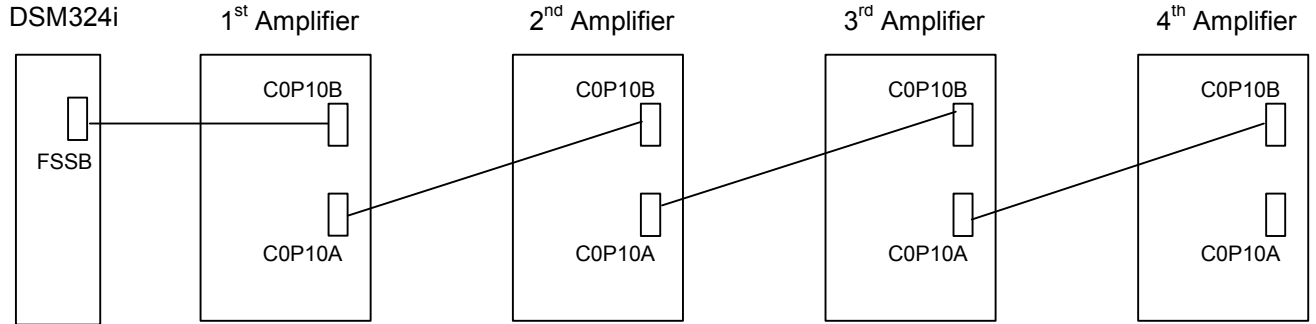

Details of Cable K1- Motor Serial Encoder Feedback

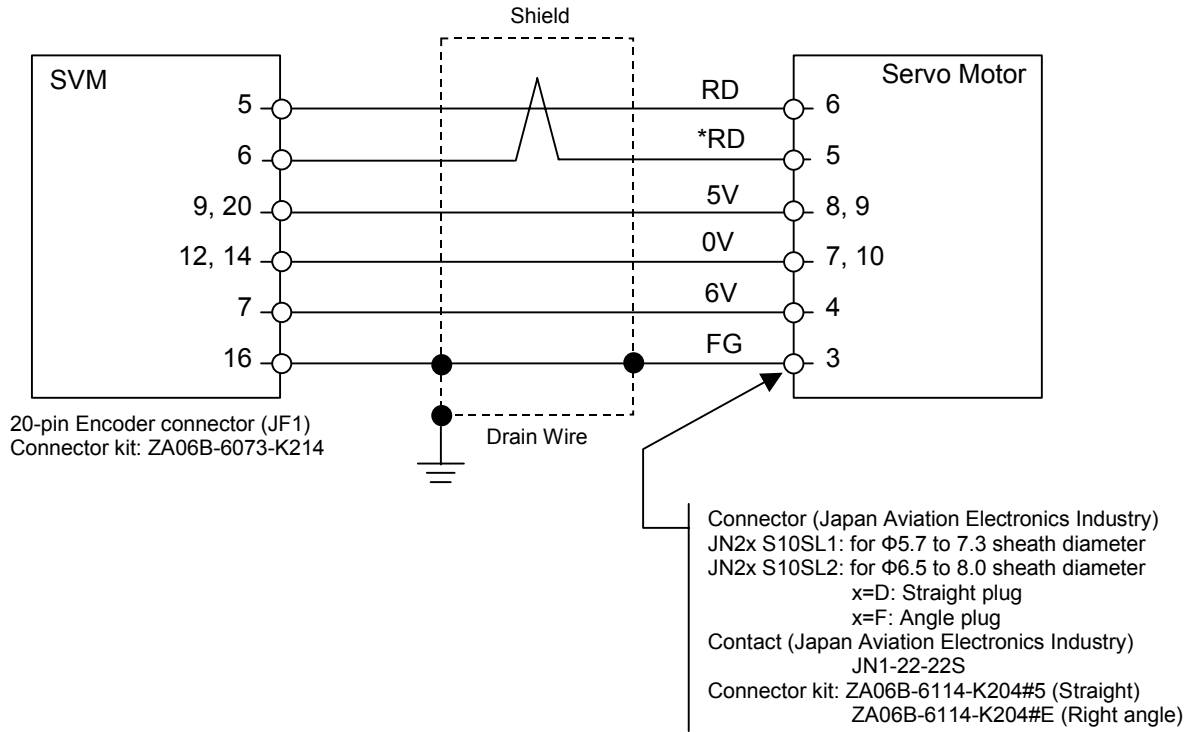

Cable K1 Connectors

The figure below shows the outside dimensions of each type of connector when engaged.

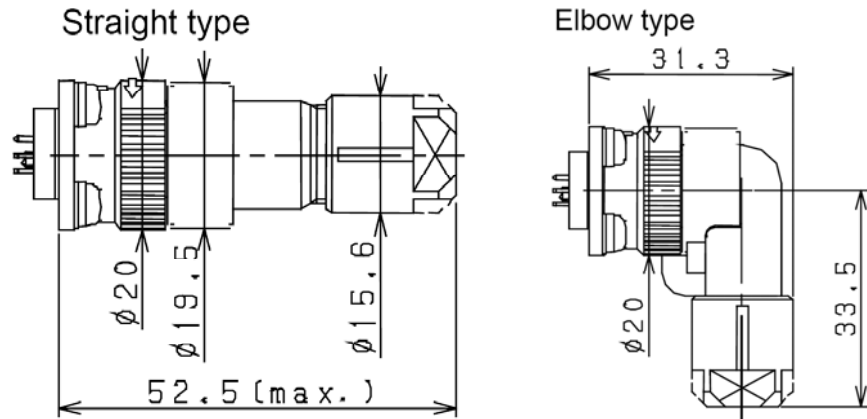

$\beta 0.4is$ to $\beta 22is$ and $\beta 2HVis$ to $\beta 22HVis$

Servo Products Specification Guide

Recommended Cable Conductors

<i>Signal</i>	<i>Cable Length</i>	
	<i>28m or Less</i>	<i>50m or Less</i>
5V, 0V, 6V	0.3mm ² x 5 Wire construction 12/0.18 or 60/0.08 Insulation outer diameter Φ1.5 or less	0.5mm ² x 5 Wire construction 20/0.18 or 104/0.08 Insulation outer diameter Φ1.5 or less
RD, *RD	0.18mm ² or more Twisted pair wire	0.18mm ² or more Twisted pair wire
Drain wire	0.15 mm ² or more	0.15 mm ² or more

Notes:

1. The grounding bar to which the feedback cable shield is connected must be placed as close as possible to the amplifier.
2. Total resistance of the 5V and 0V wire path must be less than 2Ω.
3. Motor encoder connector can accept maximum 0.5mm² wire size (wire construction 20/0.18 or 104/0.08, insulation outer diameter Φ1.5 or less) wire and sheath diameter is Φ 5.7 to Φ 8.0.

Servo Products Specification Guide

Details of Cable K2 – AC Power to β SVM1-20i Amplifier

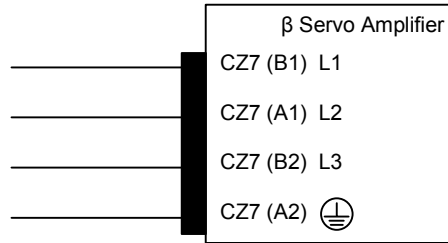

Receptacle Housing

Use the following receptacle housing.

Manufacturer Model Number	Key Specification	Manufacturer
175363-3	Incorrect-insertion prevent key	Tyco Electronics AMP

Receptacle Contact

Receptacle Contact Model Number	Conductor Size	Insulation Outer Diameter (mm)	Manual Tool Model Number	Manufacturer
L size 1-75218-2	0.5—1.25 mm ² 20/18/16 AWG	1.8—2.8	91558-1	Tyco Electronics AMP

Connector and Tool Ordering Information

Connectors (including housings and contacts) and tools can be purchased directly from Tyco Electronics AMP. Connectors can also be ordered as options from GE Intelligent Platforms as listed below.

GE Intelligent Platforms Ordering Number	Description
ZA06B-6130-K200	Housing: Incorrect-insertion prevention key 175636-3 (Qty. 1) Incorrect-insertion prevention key 1318095-2 (Qty. 1) Contact: L size, 1-175218-2 (Qty. 10) Applicable wire diameter: 0.5—1.25mm ² , AWG 20/18/16 Applicable tool: 91558-1 (not included in this kit)
	<p style="margin-left: 20px;">Connector pin location as viewed from the (back) wire insertion side.</p>

Servo Products Specification Guide

Details of Cable K2 – AC Power to β SVM1-40i Amplifier, β SVM1-10HVi, β SVM1-20HVi and β SVM1-40HVi

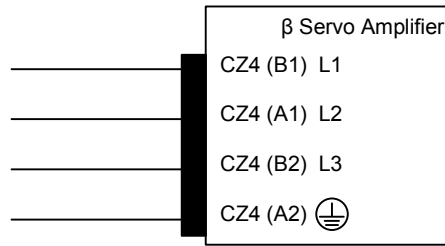

Receptacle Housing

Use the following receptacle housing.

<i>Manufacturer Model Number</i>	<i>Key Specification</i>	<i>Manufacturer</i>
1-917807-2	XX	Tyco Electronics AMP

Receptacle Contact

<i>Receptacle Contact Model Number</i>		<i>Conductor Size</i>	<i>Insulation Outer Diameter (mm)</i>	<i>Manual Tool Model Number</i>	<i>Manufacturer</i>
S size	316040-6	1.25—2.20 mm ² 16/14 AWG	3.0—3.8	234170-1	Tyco Electronics AMP

Connector and Tool Ordering Information

Connectors (including housings and contacts) and tools can be purchased directly from Tyco Electronics AMP. Connectors can also be ordered as options from GE Intelligent Platforms as listed below.

<i>GE Intelligent Platforms Ordering Number</i>	<i>Description</i>				
ZA06B-6110-K200#XXS	<p>Housing: XX key 917807-2 (Qty. 1) Contact: S size, 316040-6 (Qty. 4) Applicable wire diameter: 1.25—2.20mm², AWG 16/14 Applicable tool: 234170-1 (not included in this kit)</p> <p style="text-align: center;">CZ4</p> <table border="1" style="margin-left: auto; margin-right: auto;"> <tr> <td>A2</td> <td>A1</td> </tr> <tr> <td>B2</td> <td>B1</td> </tr> </table> <p>Connector pin location as viewed from the (back) wire insertion side.</p>	A2	A1	B2	B1
A2	A1				
B2	B1				

Servo Products Specification Guide

Details of Cable K3 – Motor Power to β SVM1-20i Amplifier

The D-3000 and D-5000 connector series manufactured by Tyco Electronic AMP are used for motor power connections to the β i series amplifiers.

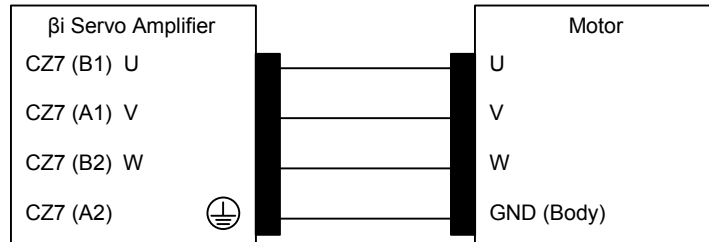

Receptacle Housing

Use the following receptacle housing.

Manufacturer Model Number	Manufacturer
1318095-2	Tyco Electronics AMP

Receptacle Contact

Receptacle Contact Model Number	Conductor Size	Insulation Outer Diameter	Manual Tool Model Number	Manufacturer
L size	1-75218-2	0.5—1.25 mm ² 20/18/16 AWG	1.8—2.8	91558-1 Tyco Electronics AMP

Connector and Tool Ordering Information

Connectors (including housings and contacts) and tools can be purchased directly from Tyco Electronics AMP. Connectors can also be ordered as options from GE Intelligent Platforms as listed below.

GE Intelligent Platforms Ordering Number	Description
ZA06B-6130-K200	Housing: Incorrect insertion prevent key 175363-3 (Qty. 1) Incorrect insertion prevent key 1318095-2 (Qty. 1) Contact: L size, 1-175218-2 (Qty. 10) Applicable wire diameter: 0.5—1.25mm ² , AWG 20/18/16 Applicable tool: 91558-1 (not included in this kit)

CZ7

U	W	G
V	G	G

Connector pin location as viewed from the (back) wire insertion side.

Servo Products Specification Guide

Details of Cable K3 – Motor Power to β SVM1-40i, β SVM1-10HVi, β SVM1-20HVi and β SVM1-40HVi Amplifiers

The D-3000 and D-5000 connector series manufactured by Tyco Electronic AMP are used for motor power connections to the β i series amplifiers.

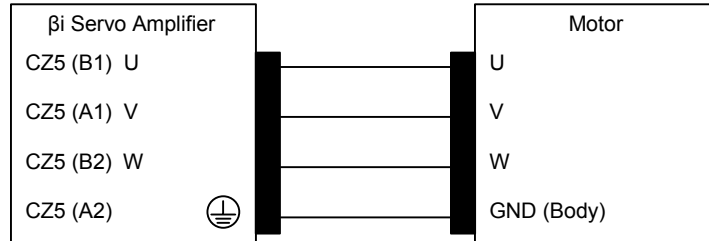

Receptacle Housing

Use the following receptacle housing.

Manufacturer Model Number	Key Specification	Manufacturer
2-917807-2	YY	Tyco Electronics AMP

Receptacle Contact

Receptacle Contact Model Number	Conductor Size	Insulation Outer Diameter	Manual Tool Model Number	Manufacturer
S size 316040-6	1.25—2.2 mm ² 16/14 AWG	3.0—3.8	234170-1	Tyco Electronics AMP

Connector and Tool Ordering Information

Connectors (including housings and contacts) and tools can be purchased directly from Tyco Electronics AMP. Connectors can also be ordered as options from GE Intelligent Platforms as listed below.

GE Intelligent Platforms Ordering Number	Description				
ZA06B-6110-K202#YY5	Housing: YY key 2-917807-2 (Qty. 1) Contact: S size 316040-6 (Qty. 4) Applicable wire diameter: 1.25—2.20mm ² , AWG 16/14 Applicable tool: 234170-1 (not included in this kit)				
	<p style="text-align: center;">CZ5</p> <table border="1" style="margin-left: auto; margin-right: auto;"> <tr> <td>G</td> <td>V</td> </tr> <tr> <td>W</td> <td>U</td> </tr> </table> <p>Connector pin location as viewed from the (back) wire insertion side.</p>	G	V	W	U
G	V				
W	U				

Details of Cables K4 and K5 – Regenerative Discharge Resistor

β SVM1-20i

When a Regenerative Discharge Resistor is Used

The following regenerative discharge resistor models are available for the β SVM1-20i amplifier. The housing and contact are connected to the resistor.

ZA06B-6130-H401	30 ohms, 20 watts
ZA06B-6130-H402	30 ohms, 100 watts

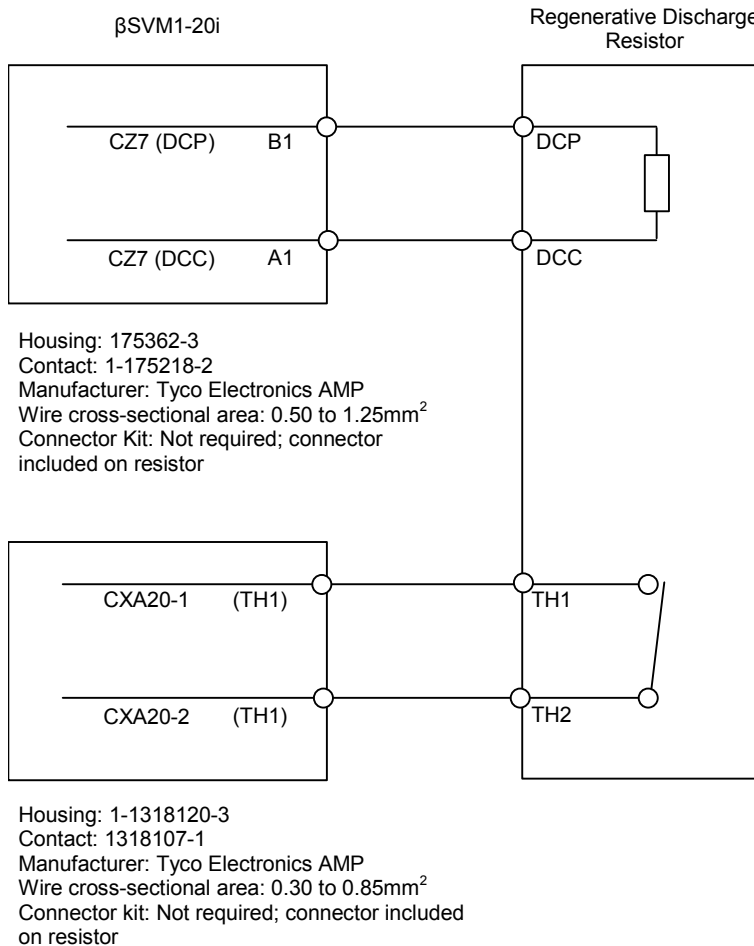

Servo Products Specification Guide

When no Regenerative Discharge Resistor is Used

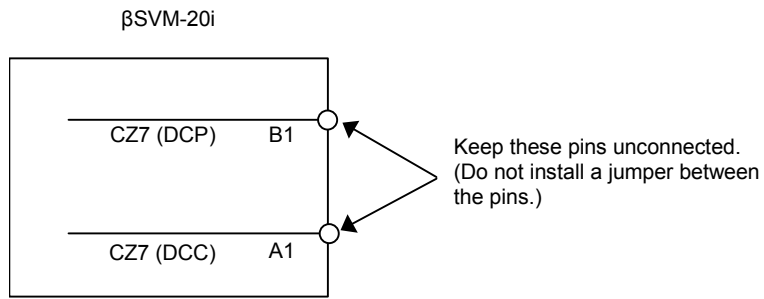

Housing: 175362-3
Contact: 1-175218-2
Manufacturer: Tyco Electronics AMP
Wire cross-sectional area: 0.50 to 1.25mm²
Connector Kit: ZA06B-6130-K200

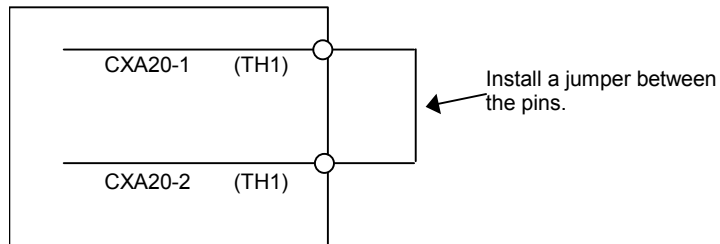

Housing: 1-1318120-3
Contact: 1318107-1
Manufacturer: Tyco Electronics AMP
Wire cross-sectional area: 0.30 to 0.85mm²
Connector Kit: ZA06B-6130-K202

Caution

Do not connect the DCP and DCC pins to each other.

βSVM1-40i

When a Separate Regenerative Discharge Resistor is Used

The following regenerative discharge resistor models are available for the βSVM1-40i amplifier. The users must manufacture the connecting cables.

ZA06B-6089-H500 16 ohms, 200 watts

ZA06B-6089-H713 16 ohms, 200 watts

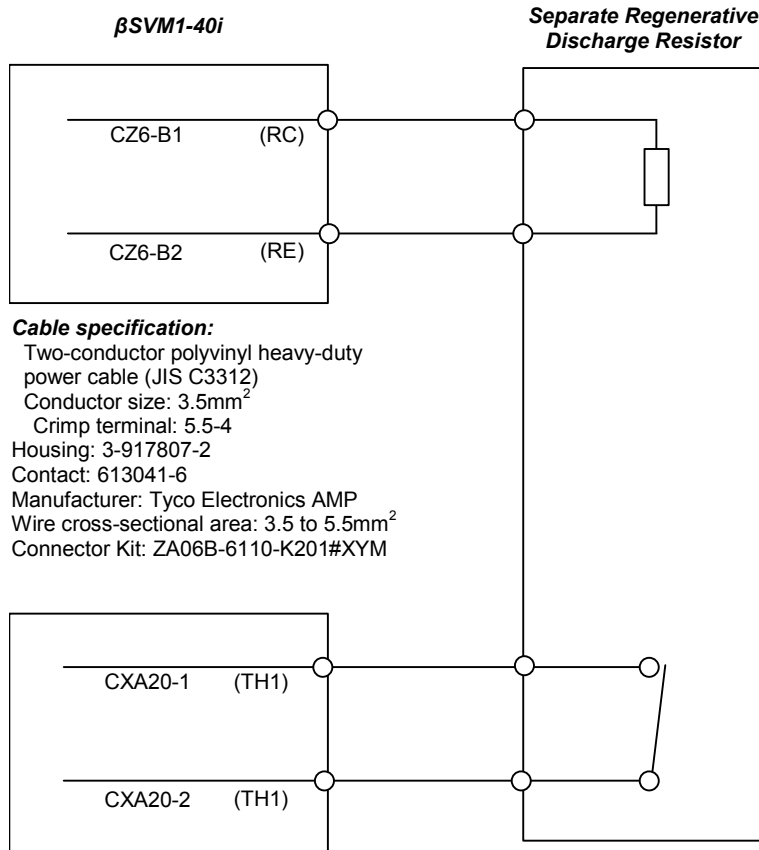

Cable specification:

Two-conductor polyvinyl heavy-duty power cable (JIS C3312)
 Conductor size: 3.5mm²
 Crimp terminal: 5.5-4
 Housing: 3-917807-2
 Contact: 613041-6
 Manufacturer: Tyco Electronics AMP
 Wire cross-sectional area: 3.5 to 5.5mm²
 Connector Kit: ZA06B-6110-K201#XYM

Cable specification:

Two-conductor polyvinyl heavy-duty power cable (JIS C3312)
 Conductor size: 0.75mm²
 Crimp terminal: 1.25-4
 Housing: 1-1318120-3
 Contact: 1318107-1
 Manufacturer: Tyco Electronics AMP
 Wire cross-sectional area: 0.3 to 0.85mm²
 Connector Kit: ZA06B-6130-K202

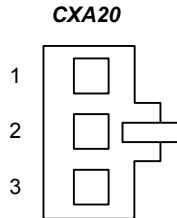
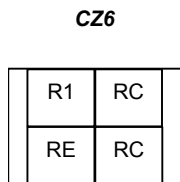

Connector pin location as viewed from the (back) wire insertion side.

Servo Products Specification Guide

When a Built-in Regenerative Discharge Resistor is Used

βSVM1-40i

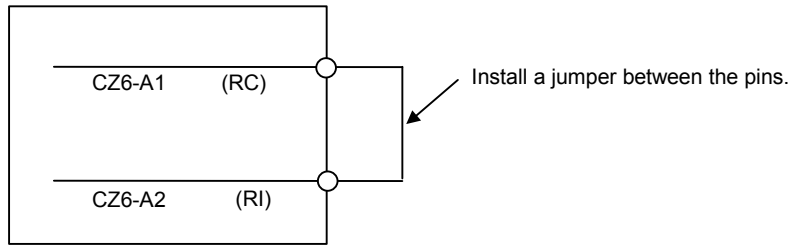

Cable specification:

Two-conductor polyvinyl heavy-duty power cable (JIS C3312)
Conductor size: 3.5mm²
Crimp terminal: 5.5-4

Housing: 3-917807-2

Contact: 613041-6

Manufacturer: Tyco Electronics AMP

Wire cross-sectional area: 3.5 to 5.5mm²

Connector Kit: ZA06B-6110-K201#XYM

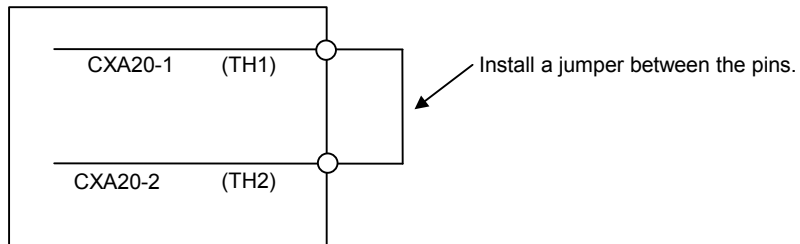

Cable specification:

Two-conductor polyvinyl heavy-duty power cable (JIS C3312)
Conductor size: 0.75mm²
Crimp terminal: 1.25-4

Housing: 1-1318120-3

Contact: 1318107-1

Manufacturer: Tyco Electronics AMP

Wire cross-sectional area: 0.3 to 0.85mm²

Connector Kit: ZA06B-6130-K202

βSVM1-10HVi, βSVM1-20HVi and βSVM1-40HVi

When a Separate Regenerative Discharge Resistor is Used

The following regenerative discharge resistor model is available for the βSVM1-10HVi, βSVM1-20HVi and βSVM1-40HVi amplifiers. The users must manufacture the connecting cables.

ZA06B-6130-H403 16 ohms, 800 watts

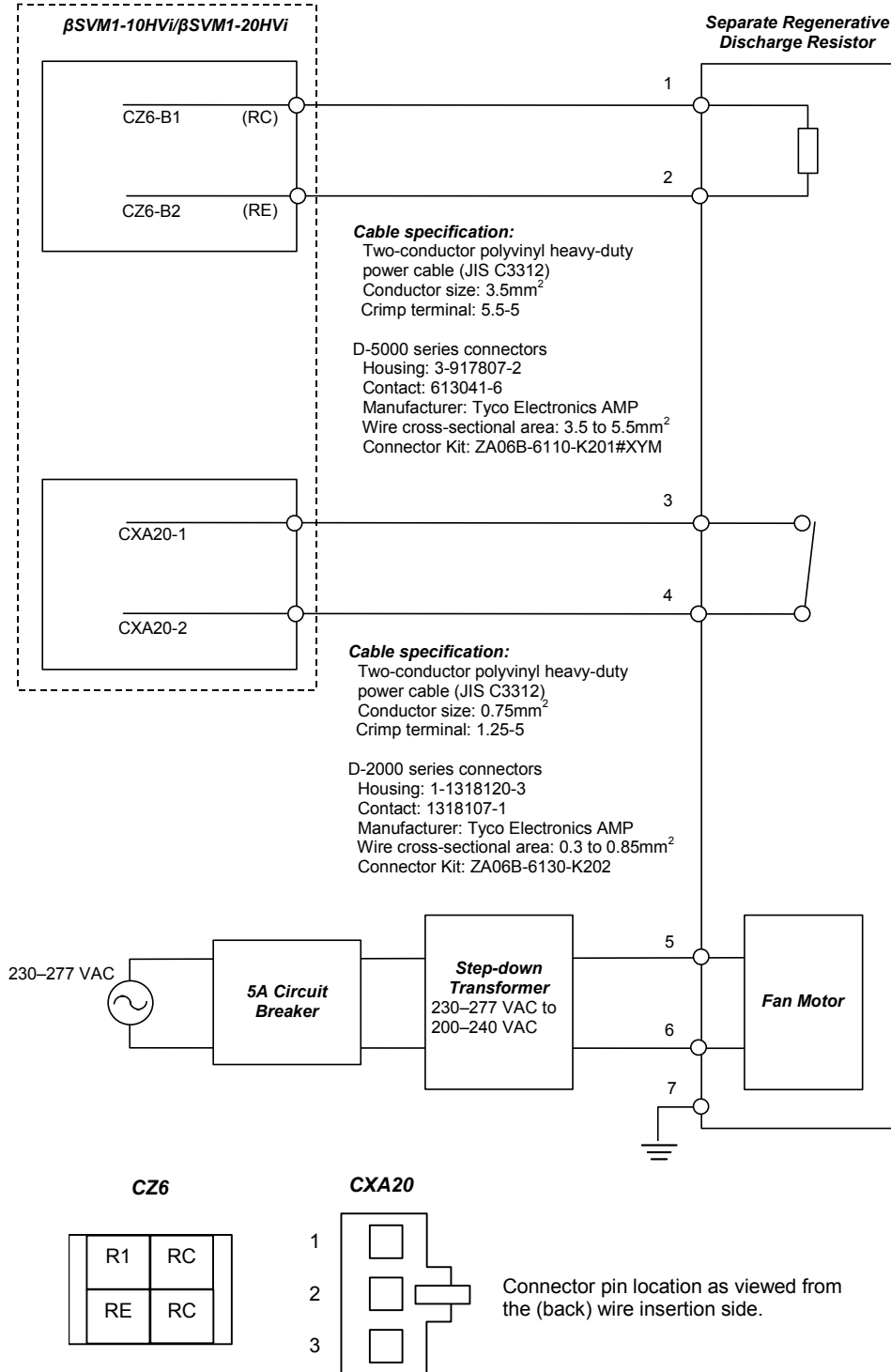

Servo Products Specification Guide

When a Built-in Regenerative Discharge Resistor is Used

The β SVM1-10HVi, β SVM1-20HVi and β SVM1-40HVi amplifiers should be wired as follows when using the built-in regenerative discharge resistor:

β SVM1-10HVi

β SVM1-20HVi

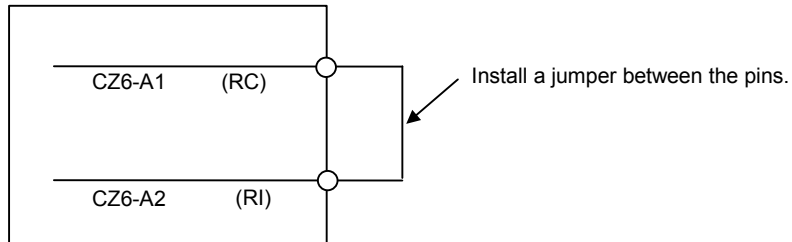

Cable specification:

Two-conductor polyvinyl heavy-duty power cable (JIS C3312)

Conductor size: 3.5mm²

Crimp terminal: 5.5-4

Housing: 3-917807-2

Contact: 613041-6

Manufacturer: Tyco Electronics AMP

Wire cross-sectional area: 3.5 to 5.5mm²

Connector Kit: ZA06B-6110-K201#XYM

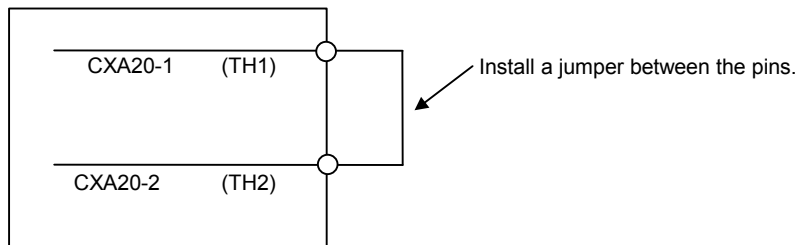

Cable specification:

Two-conductor polyvinyl heavy-duty power cable (JIS C3312)

Conductor size: 0.75mm²

Crimp terminal: 1.25-4

Housing: 1-1318120-3

Contact: 1318107-1

Manufacturer: Tyco Electronics AMP

Wire cross-sectional area: 0.3 to 0.85mm²

Connector Kit: ZA06B-6130-K202

Details of Cable K6 – 24V, E-Stop and Battery Daisy Chain for Multi-Axis Systems

For multi-axis systems, the 24VDC control power, emergency stop, and absolute encoder backup battery signals can be daisy chained from the first amplifier to up to three adjacent amplifiers using the CXA19 connections. The state of the E-stop input signal on connector CX30 on the first amplifier is passed to the other connected amplifiers, allowing an emergency stop condition to be executed on all amplifiers simultaneously. When using this connection for the encoder battery backup, the IC800ABK001 multi-axis battery kit must be connected to the first amplifier. Do not use the IC800BBK021 single-axis battery kit.

Warning

Wiring 24VDC to the incorrect pins will cause amplifier and motor damage. Always confirm proper voltage on the pins before connecting the cable.

Warnings

When connecting two or more servo amplifiers, be careful about the way the ESP (A3) signal is connected, because even when the emergency stop button is pressed, it may fail to stop the motor promptly. For details, see "Details of Cable K8" on page III-93.

When using the built-in battery (A06B-6093-K001), never connect the BAT (B3) of the connector CXA19A/CXA19B. Otherwise, a short circuit will occur between the battery output voltages for different SVMs, possibly resulting in the batteries becoming very hot, which is dangerous.

Do not connect more than one battery to the same BAT (B3) line. Otherwise, a short circuit will occur between the output voltages of different batteries, possibly resulting in the batteries becoming very hot, which is dangerous.

Servo Products Specification Guide

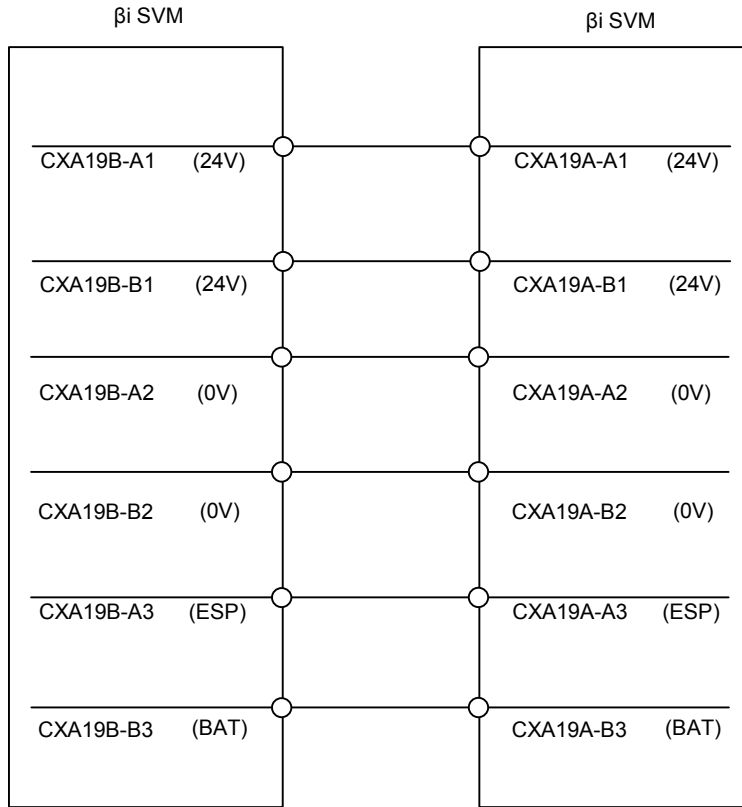

D2000 series
 Housing: 1-1318119-3
 Contact: 1318107-1
 Manufacturer: Tyco Electronics AMP
 Wire cross-sectional area: 0.3 to 0.85mm²
 Connector Kit: ZA06B-6130-K201

D2000 series
 Housing: 1-1318119-3
 Contact: 1318107-1
 Manufacturer: Tyco Electronics AMP
 Wire cross-sectional area: 0.3 to 0.85mm²
 Connector Kit: ZA06B-6130-K201

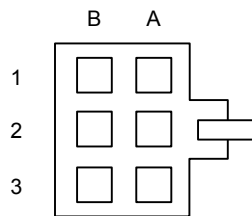

CXA19 connector pin location as viewed from the (back) wire insertion side.

Details of Cable K7 – E-Stop/Power Enable (MCC)

This cable is used to connect the normally open relay contacts on connector CX29 to the power source of the magnetic contactor coil used to interrupt AC power to the amplifier when an amplifier fault occurs or E-stop condition occurs.

The relay contact will close when the amplifier is enabled by the DSM324i controller (MCON signal sent) as long as there are no active servo alarms and the E-stop input on connector CX30 is closed. The relay contacts will open when any one or more of the following conditions occurs:

1. 24 VDC power is removed from the amplifier.
2. A servo alarm occurs on the amplifier.
3. The emergency stop input (CX30) to the amplifier is opened.
4. DSM324i enable (MCON) is 0.

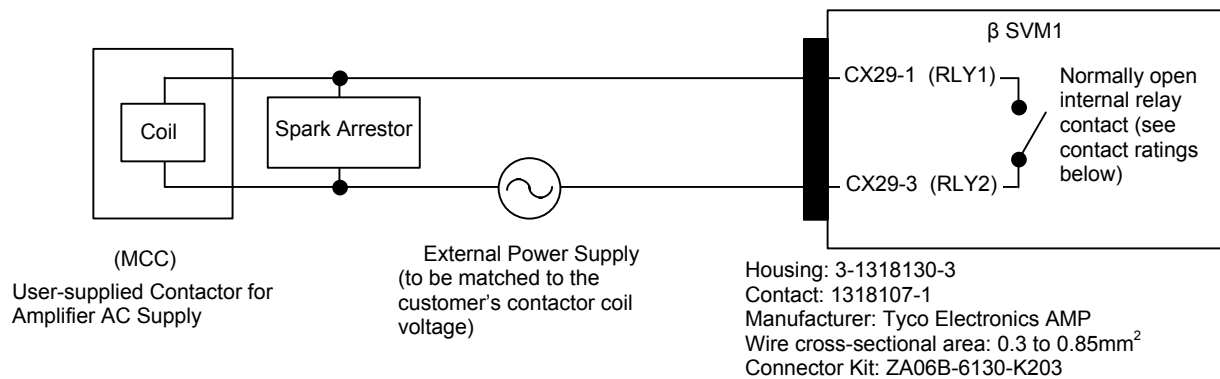

Contact Ratings

Specification of Internal Contact	Resistor Load ($\cos\phi=1$)	Inductance Load ($\cos\phi=0.4, L/R=7msec$)
Rated load	250 VAC, 3A 24 VDC, 5A	250 VAC, 2A 24 VDC, 2A
Max. current	5A	5A

CX29 (MCC)

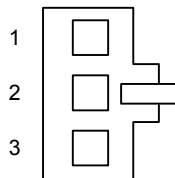

Connector pin location as viewed from (back) wire insertion side

Servo Products Specification Guide

Details of Cable K8 – Servo Amplifier Emergency Stop Connection

The state of this signal input (ESP) is reflected on the CXA19 connector pin A3, allowing one E-stop input to be used for all amplifiers in a multi-axis system (see cable K6). When the E-stop input is open, the MCC relay contacts on connector CX29 will open.

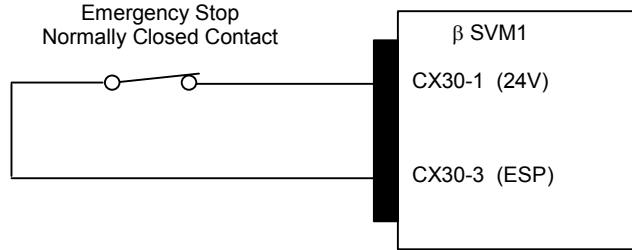

Housing: 2-1318120-3
Contact: 1318107-1
Manufacturer: Tyco Electronics AMP
Wire cross-sectional area: 0.3 to 0.85mm²
Connector Kit: ZA06B-6130-K204

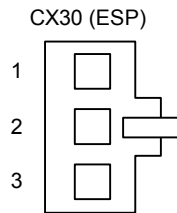

Connector pin location as viewed from the (back) wire insertion side

Details of Cable K9 – Optional External Absolute Encoder Battery Connection

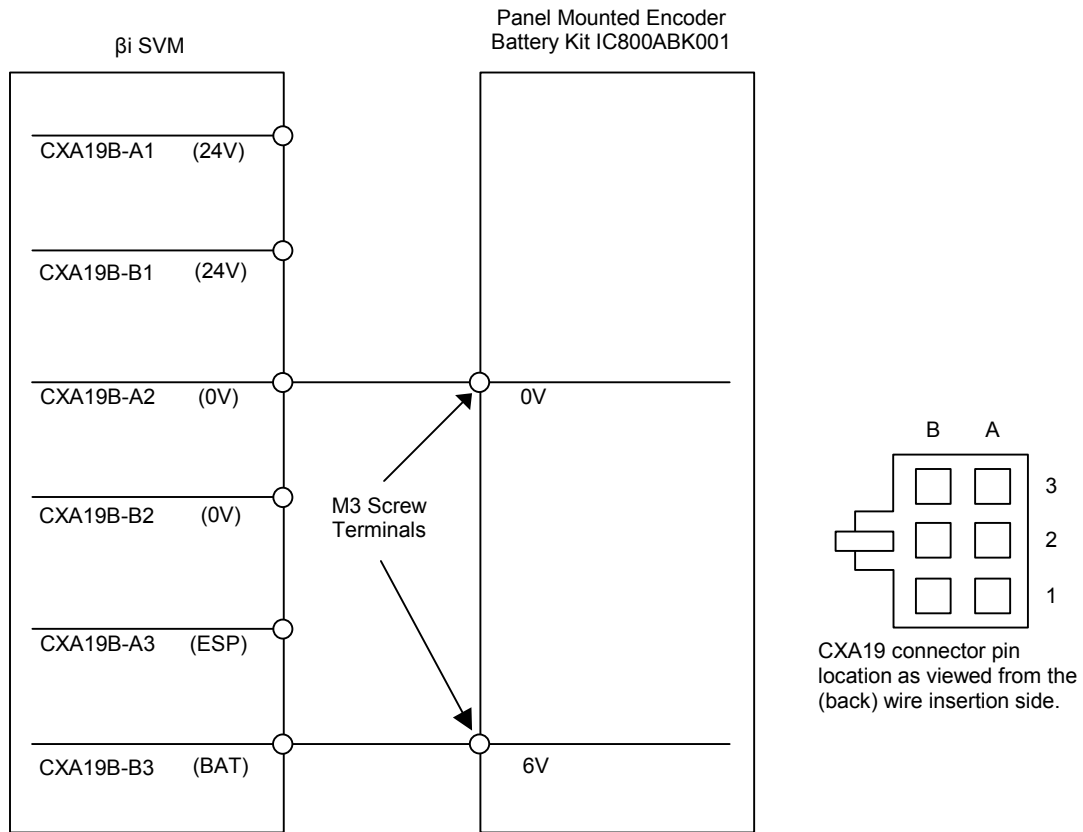

Housing: 1-1318119-3
 Contact: 1318107-1
 Manufacturer: Tyco Electronics AMP
 Wire cross-sectional area: 0.3 to 0.85mm²
 Connector Kit: ZA06B-3160-K201

Crimp terminal: 1.25-2
 Wire cross-sectional area: 0.3 to 0.85mm²

Details of Cable K10 –External Cooling Fan Connector

The β i Series amplifiers include a 3-pin connector on the top of the amplifier for connection to an external cooling fan.

The following amplifier/motor combinations require a fan:

β SVM1-20i with β 4/4000is when single-phase input power is used

β SVM1-20i with β 8/3000is

β SVM1-40HVi with all motors

For systems that *do not* require a fan, the fan connector and associated jumper wire must be installed or an alarm will be generated. The amplifier is shipped with this jumper/connector (T892) installed.

Replacement connector: ZA06B-6130-K202 (wire jumper must be installed by user).

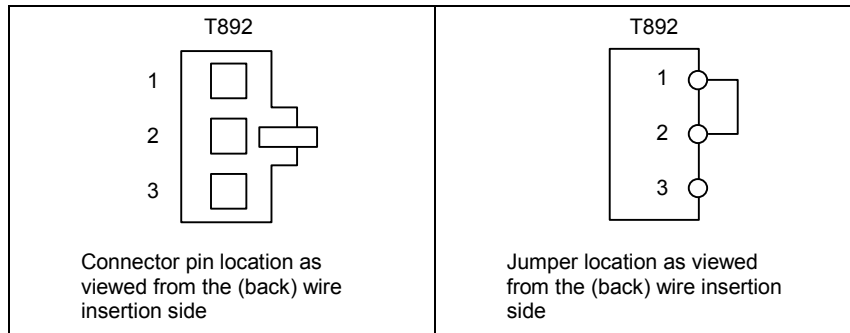

Part IV:
αi and αHVi
Series Servo
Systems

Section 25: ai and αHVi Series Servos Overview

25.1 ai and αHVi Series Servo Systems

The α HVi Series servos are high voltage models with an AC voltage input range of 400-480 VAC and include separately mounted shared power supply modules. These power supply modules offer line regeneration capability which eliminates the need for external power resistors to dissipate regenerated energy during motor deceleration. Depending on the motor rating up to six amplifiers can be connected to one power supply.

Table **2HIV-1** provides a summary of ais Series servo motors supported by the DSM324i and PACMotion controllers for general motion applications. See Section 27: for more detailed motor specifications.

Table IV-1. ais Series Servo Systems (400—480 VAC Main Power)

Motor Model No.	Rated Torque	Encoder (built-in)	Required Amplifier	Motor Catalog No.*
α2/6000HVis	2 Nm continuous stall torque; 6000 RPM	aiA 1000	αSVM1-10HVi βSVM1-10HVi	Motor Only: ZA06B-0219-B200 Motor w/Brake: ZA06B-0219-B500
α4/5000HVis	4 Nm continuous stall torque; 5000 RPM	aiA 1000	αSVM1-10HVi βSVM1-10HVi	Motor Only: ZA06B-0216-B200 Motor w/Brake: ZA06B-0216-B500
α8/6000HVis	8 Nm continuous stall torque; 6000 RPM	aiA 1000	αSVM1-40HVi βSVM1-40HVi	Motor Only: ZA06B-0233-B200 Motor w/Brake: ZA06B-0233-B500
α12/4000HVis	12 Nm continuous stall torque; 4000 RPM	aiA 1000	αSVM1-40HVi βSVM1-40HVi	Motor Only: ZA06B-0239-B200 Motor w/ Brake: ZA06B-0239-B500
α22/3000i	22 Nm continuous stall torque; 3000 RPM	aiA 1000	βSVM1-80i	Motor Only: ZA06B-247-B200 Motor w/ Brake: ZA06B-247-B500
α22/3000HVi	22 Nm continuous stall torque; 3000 RPM	aiA 1000	αSVM1-40HVi βSVM1-40HVi	Motor Only: ZA06B-0249-B200 Motor w/ Brake: ZA06B-0249-B500
α22/4000HVis	22 Nm continuous stall torque; 4000 RPM	aiA 1000	αSVM1-80HVi	Motor Only: ZA06B-0266-B200 Motor w/ Brake: ZA06B-0266-B500
α30/4000HVis	30 Nm continuous stall torque; 4000 RPM	aiA 1000	αSVM1-80HVi	Motor Only: ZA06B-0269-B200 Motor w/ Brake: ZA06B-0269-B500
α40/4000HVis	40 Nm continuous stall torque; 4000 RPM	aiA 1000	αSVM1-80HVi	Motor Only: ZA06B-0273-B200 Motor w/ Brake: ZA06B-0273-B500
α50/3000HVis with fan	75 Nm continuous stall torque; 3000 RPM	aiA 1000	αSVM1-180HVi	Motor Only: ZA06B-0276-B210 Motor w/ Brake: ZA06B-0276-B510

* All motors include straight shaft and key.

25.2 *ai* Series Servo Amplifier Packages

The following table shows which amplifier model is included in each *ai* Series servo package.

Table IV-2. α HVi Series Servo Amplifiers and Packages

<i>Motor</i>	<i>Amplifier Model</i>	<i>Amplifier Catalog #</i>	<i>Amplifier Kit Catalog #</i>
α 2/6000HVVis	α SVM1-10HVi β SVM1-10HVi*	ZA06B-6127-H102 ZA06B-6131-H001	IC800AIHV010 IC800BIHV010
α 4/5000HVVis	α SVM1-10HVi β SVM1-10HVi*	ZA06B-6127-H102 ZA06B-6131-H001	IC800AIHV010 IC800BIHV010
α 8/6000HVVis	α SVM1-40HVi β SVM1-40HVi*	ZA06B-6127-H104 ZA06B-6131-H003	IC800AIHV040 IC800BIHV040
α 12/4000HVVis α 22/3000HVVis	α SVM1-40HVi β SVM1-40HVi*	ZA06B-6127-H104 ZA06B-6131-H003	IC800AIHV040 IC800BIHV040
α 22/4000HVVis α 30/4000HVVis	α SVM1-80HVi	ZA06B-6127-H105	IC800AIHV080
α 40/4000HVVis	α SVM1-80HVi	ZA06B-6127-H105	IC800AIHV80
α 50/3000HVVis with fan	α SVM1-180HVi	ZA06B-6127-H106	IC800AIHV180

*For β SVM1-HVi details, refer to Part III, β i and β HVi Series Servo Systems.”

As a convenience, amplifiers can also be ordered as a package containing all of the components required to operate the amplifier in a servo system, as detailed in the following table:

Table IV-3. α HVi Series Servo Amplifier Kits

<i>Description</i>	<i>Package Contents*</i>	<i>Catalog #</i>
α HVi-series 40A amplifier kit	<ul style="list-style-type: none"> ■ αSVM1-40HVi Amplifier, Qty 1 ■ Amplifier connectors, ■ Bus bar kit ■ ZA06B-6073-K250, Amplifier spare Control Power Fuse, Qty 1 	IC800AIHV040
α HVi-series 80A amplifier kit	<ul style="list-style-type: none"> ■ αSVM1-80HVi Amplifier, Qty 1 ■ Amplifier connectors ■ Bus bar kit ■ ZA06B-6073-K250, Amplifier spare Control Power Fuse, Qty 1 	IC800AIHV080
α HVi-series 180A amplifier kit	<ul style="list-style-type: none"> ■ αSVM1-180HVi Amplifier, Qty 1 ■ Amplifier connectors ■ Bus bar kit ■ ZA06B-6073-K250, Amplifier spare Control Power Fuse, Qty 1 <p>Amplifier αSVM1-180HVi requires dynamic braking module ZA06B-6079-H401.</p>	IC800AIHV180

* Amplifier package components can also be ordered separately.

Section 26: α HVi Servo System Options

Designing a servo control system requires that you understand how the electrical and mechanical aspects of your system interact. The table below will help you select which servo options your system requires.

Table IV-4. α i Servo System Options

Servo Option	Consider Selecting When	Catalog #	Section #
Motor Holding Brake	The system design includes an axis that must hold its position when power is removed	Refer to Table 2HIV-1	27.4
Absolute Encoder Battery Backup Kit	You want to avoid having to re-reference the position when power is restored to the control	IC800ABK001 (4-axis) IC800ABK002 (1-axis)	28.4
AC Line Filters	200—240 VAC is already available to the control cabinet and no isolation transformer is used	5.4 kW, 3-phase: ZA81L-0001-0083#3C 10.5 kW, 3-phase: ZA81L-0001-0101#C	23.2
Pre-finished Cables	The cable lengths available are appropriate for your application	Refer to “Cable Connections” Table	Section 33:
Ground Clamp	CE Installation or high electrical noise environment.	ZA99L-0035-0001, Clamp Z44B295864-001, Bar	31.3
Absolute Encoder Battery Backup Connector	You want to daisy chain multiple amplifiers together to share the multi-axis battery pack IC800ABK001.	ZA06B-6093-K303	28.4

Table IV-5. α HVi Servo System Options

Servo Option	Consider Selecting When	Catalog #	Section #
Motor Holding Brake	The system design includes an axis that must hold its position when power is removed	Refer to Table 2HIV-1	27.4
Absolute Encoder Battery Backup Kit	You want to avoid having to re-reference the position when power is restored to the control	IC800ABK001 (four-axis) IC800ABK002 (one-axis) IC800ABK003, for α SVM1-180HVi Amplifier only	28.4
AC Line Filters	400—480 VAC is already available to the control cabinet and no isolation transformer is used	ZA81L-0001-0163 ZA81L-0001-0164	32.2
Pre-finished Cables	The cable lengths available are appropriate for your application	Refer to “Cable Connections” tables	Section 33:
Ground Clamp	CE Installation or high electrical noise environment.	ZA99L-0035-0001, Clamp Z44B295864-001, Bar	31.3
Absolute Encoder Battery Backup Connector	You want to daisy chain multiple amplifiers together to share the multi-axis battery pack IC800ABK001.	ZA06B-6093-K303	28.4

Section 27: Servo Motors

27.1 Servo Motor Specifications

The αi Series Servo system consists of a servomotor and its corresponding amplifier and cables.

Table IV-6. Specifications of the αi Servo Motor

	<i>Unit</i>	<i>$\alpha 22/3000i$</i>
Rated torque at stall *	Nm	22
	lbf-in	194.7
Stall Current *	A (rms)	18.4
Rated Output *	kW	4.0
	HP	5.4
Rated Speed	RPM	3000
Max. Speed	RPM	3000
Encoder Resolution	Counts/Rev	
Absolute	1,000,000	
Flange Size	mm	
Peak Torque *	Nm	64
	lb-in	566.4
Rotor Inertia	Kgm ²	0.0120
	lb-in-s ² *(10 ⁻⁶)	0.1062
Rotor Inertia (with brake)	Kgm ²	0.0126
	lb-in-s ² *(10 ⁻⁶)	0.1115
Torque Constant *	Nm/A	1.20
	Lb-in/A	10.62
Back EMF Const. (1 phase)*	V _{rms} /1000 rpm	42
Resistance (1 phase) *	ohm	0.16
Mechanical Time Constant	sec	0.004
Thermal time Constant	min	60
Static friction	Nm	1.2
Weight	kg	29
	lb	63.8
Weight (with brake)	kg	35
	lb	77
Axial Load Rating	kg	60
Radial Load Rating	kg	200
Max Current	A (peak)	80

* These values are standard values at 20°C with a tolerance of $\pm 10\%$. The speed-torque characteristics vary, depending on the type of software, parameter setting, and input voltage of the digital servo amplifiers. (The above figures show average values.) These values may be changed without prior notice.

Servo Products Specification Guide

Table IV-7. Specifications of α HVi Servo Motors

	Unit	$\alpha 2/6000HVis$	$\alpha 4/5000HVis$	$\alpha 8/6000HVis$	$\alpha 12/4000HVis$	$\alpha 22/3000HVi$	$\alpha 22/4000HVis$
Rated torque at stall *	Nm	2	4	8	12	22	22
	lbf-in	17.7	35.4	70.8	106.2	194.7	194.7
Stall Current *	A (rms)	2	3	9	6.7	91.11	15.5
Rated Output *	KW	1.0	1.0	2.2	2.5	4.04	4.5
	HP	1.3	1.3	3	3.4	5.4	6
Rated Speed	RPM	6000	4000	6000	3000	3000	3000
No Load Speed	RPM	6000	5000	6000	4000	3000	4000
Encoder Resolution	Counts/Rev absolute	1,000,000	1,000,000	1,000,000	1,000,000	1,000,000	1,000,000
Flange Size	mm	90	90	130	130	174	174
Peak Torque *	Nm	6	8.8	22	46	64	70
	lbf-in	53.1	77.9	194.7	407.14	566.4	619.6
Rotor Inertia	Kgm ² x 10 ⁴	2.91	5.15	11.7	22.8	120	52.7
	lb-in-s ² x 10 ⁴	25.75	45.58	103.54	201.7	1062	466.4
Rotor Inertia (with brake)	Kgm ² x 10 ⁴	3.11	5.25	12.4	23.5	126	58.7
	lb-in-s ² x 10 ⁴	29.52	105.27	109.72	208	1115	519.5
Torque Constant *	Nm/A	0.99	1.32	0.89	1.8	2.41	1.42
	Lbf-in/A	8.76	11.68	7.87	15.9	21.3	12.6
Back EMF Const. (1 phase) *	V _{rms} /1000 rpm	35	46	31	63	84	50
Resistance (1 phase) *	ohm	5.6	2.8	0.5	0.84	0.66	0.25
Mechanical Time Constant	sec	5	3	2	0.002	0.004	0.002
Thermal time Constant	min	15	20	20	25	60	30
Static friction	Nm	0.1	0.2	0.3	0.3	1.2	0.8
Weight	kg	3	4.3	8	11.9	29	17
	lb	6.6	9.46	17.6	26.2	63.8	37.48
Weight (with brake)	kg	4	5.3	10.2	14.1	35	23
	lb	8.8	11.66	22.5	31.1	77	50.7
Axial Load Rating	kg	8	8	20	20	60	60
	lb	17.6	17.6	44	44	132	132
Radial Load Rating	kg	25	25	70	70	200	200
	lb	55	55	154	154	440	440
Max Current	A (peak)	40	40	40	40	40	80

*These values are standard values at 20°C with a tolerance of $\pm 10\%$. The speed-torque characteristics vary, depending on the type of software, parameter setting, and input voltage of the digital servo amplifiers. (The above figures show average values.) These values may be changed without prior notice.

Servo Products Specification Guide

Table IV-8. Specifications of α 30HVis, α 40HVis and α 50HVis Servo Motors

	<i>Unit</i>	<i>α30/4000HVis</i>	<i>α40/4000HVis</i>	<i>α50/3000HVis with Fan</i>
Rated torque at stall *	Nm	30	40	75
	lbf-in	265.5	354.0	663.8
Stall Current *	A (rms)	15.9	18.1	39.6
Rated Output *	kW	5.5	5.5	14
	HP	7.4	7.4	19
Rated Speed	RPM	3000	3000	3000
No Load Speed	RPM	4000	4000	3000
Encoder Resolution	Counts/Rev	1,000,000	1,000,000	1,000,000
Flange Size	mm	174	174	174
Peak Torque *	Nm	100	115	215
	lbf-in	885.1	1017.9	1903
Rotor Inertia	Kgm ² x 10 ⁴	75.9	99	145
	lb-in-s ² x 10 ⁴	671.7	8761	1283
Rotor Inertia (with brake)	Kgm ² x 10 ⁴	81.9	105	151
	lb-in-s ² x 10 ⁴	7248	929	1336
Torque Constant *	Nm/A	1.9	2.21	1.9
	lbf-in/A	16.8	19.6	1638
Back EMF Const. (1 phase) *	V _{rms} /1000 rpm	66	77	66
Resistance (1 phase) *	ohm	0.25	0.23	0.1
Mechanical Time Constant	sec	0.002	0.001	0.001
Thermal time Constant	min	35	40	30
Static friction	Nm	0.8	1.2	1.8
Weight	kg	23	28	39
	lb	50.7	61.7	86.0
Weight (with brake)	kg	29	34	42
	lb	63.9	75.0	92.6
Axial Load Rating	kg	60	60	60
	lb	132	132	132
Radial Load Rating	kg	200	200	200
	lb	440	440	440
Max Current	A (peak)	80	80	180

*These values are standard values at 20°C with a tolerance of $\pm 10\%$. The speed-torque characteristics vary, depending on the type of software, parameter setting, and input voltage of the digital servo amplifiers. (The above figures show average values.) These values may be changed without prior notice.

27.2 *ai* and *αHVis* Series Motor Speed–Torque Curves

The curves shown in the following figure illustrate the relationship between the speed of the motor and the output torque. The motor can operate continuously at any combination of speed and torque within the prescribed continuous operating zone. The limit of the continuous operating zone is determined with the motor’s ambient temperature at 20°C and its drive current as pure sine wave. The curves reflect peak torque limits based on maximum current of the servo amplifier unit.

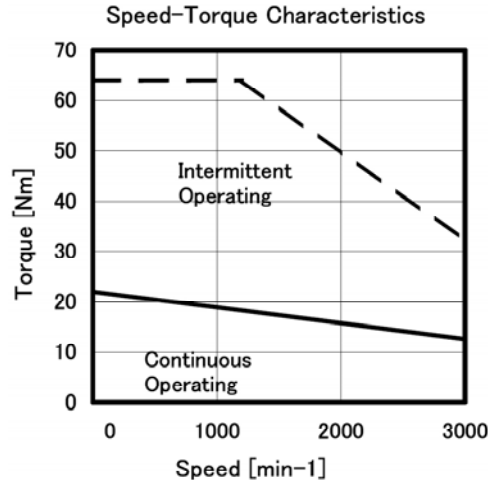

Figure IV-1. *ai* Series Servo Motor Speed-Torque Curve ($\alpha 22/3000i$)

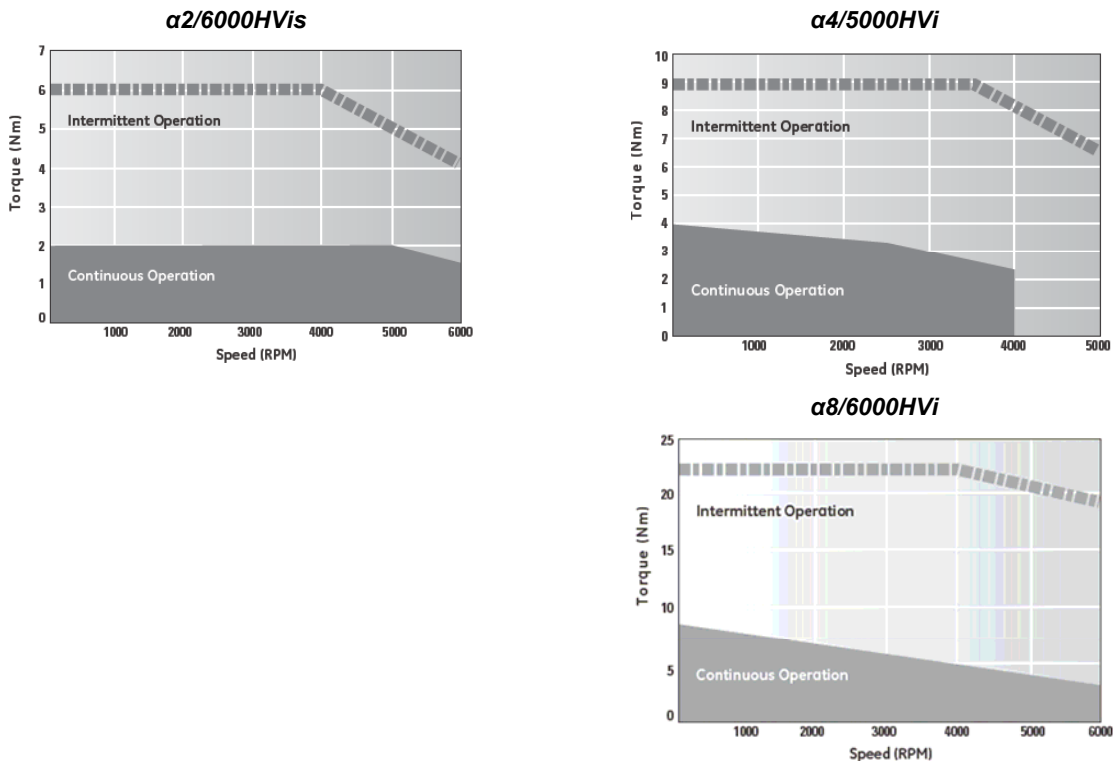

Figure IV-2. *αHVis* Series Servo Motor Speed-Torque Curves ($\alpha 2/6000HVIs$, $\alpha 4/5000HVIs$ and $\alpha 8/6000HVIs$)

Servo Products Specification Guide

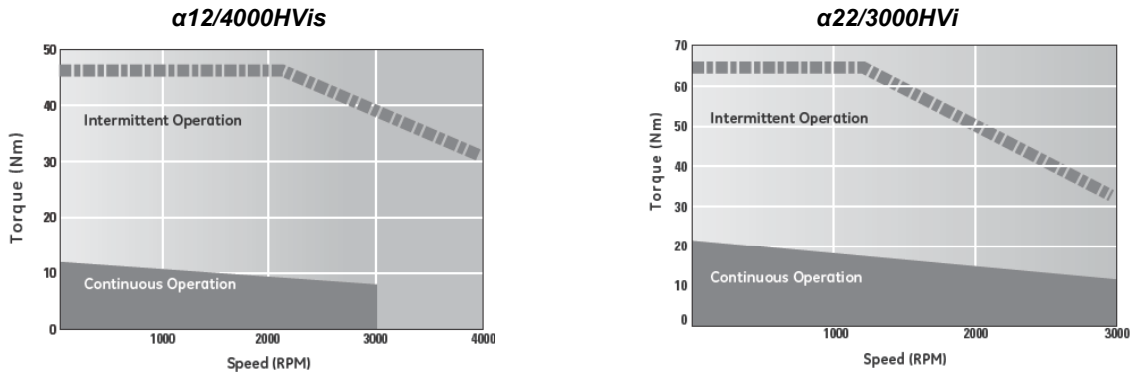

Figure IV-3. αHVi Series Servo Motor Speed-Torque Curves (α12/4000HVIs and α22/3000HVVi)

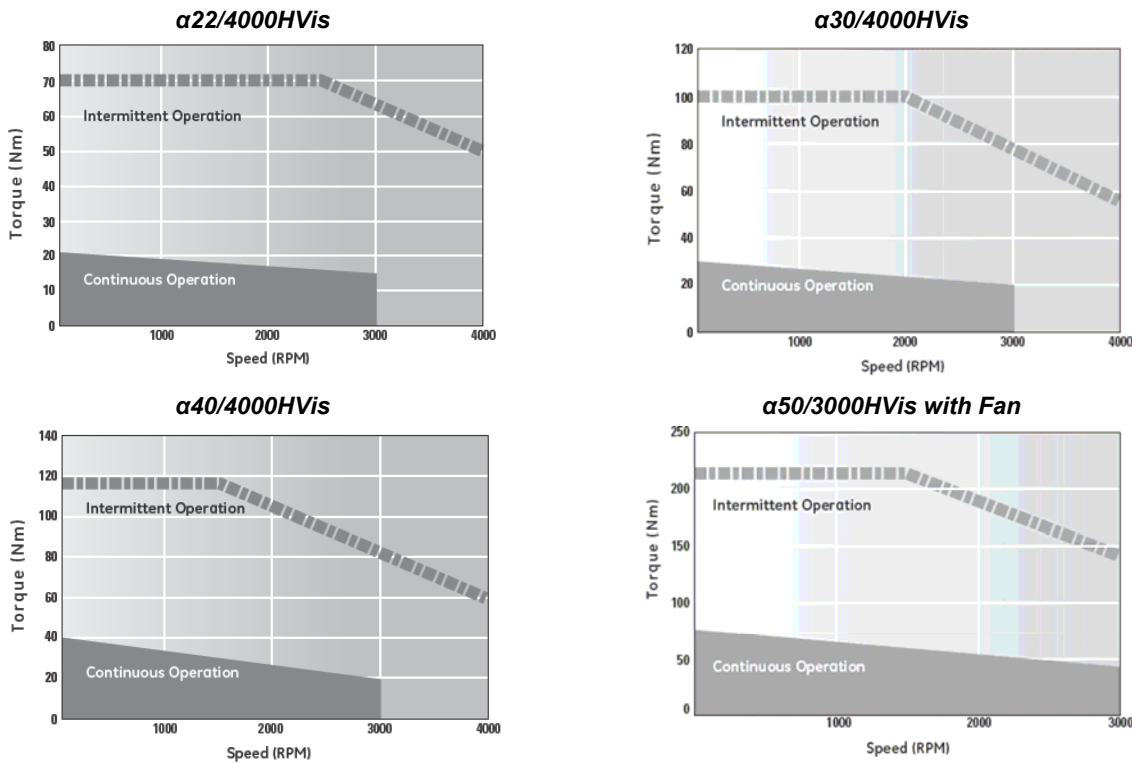
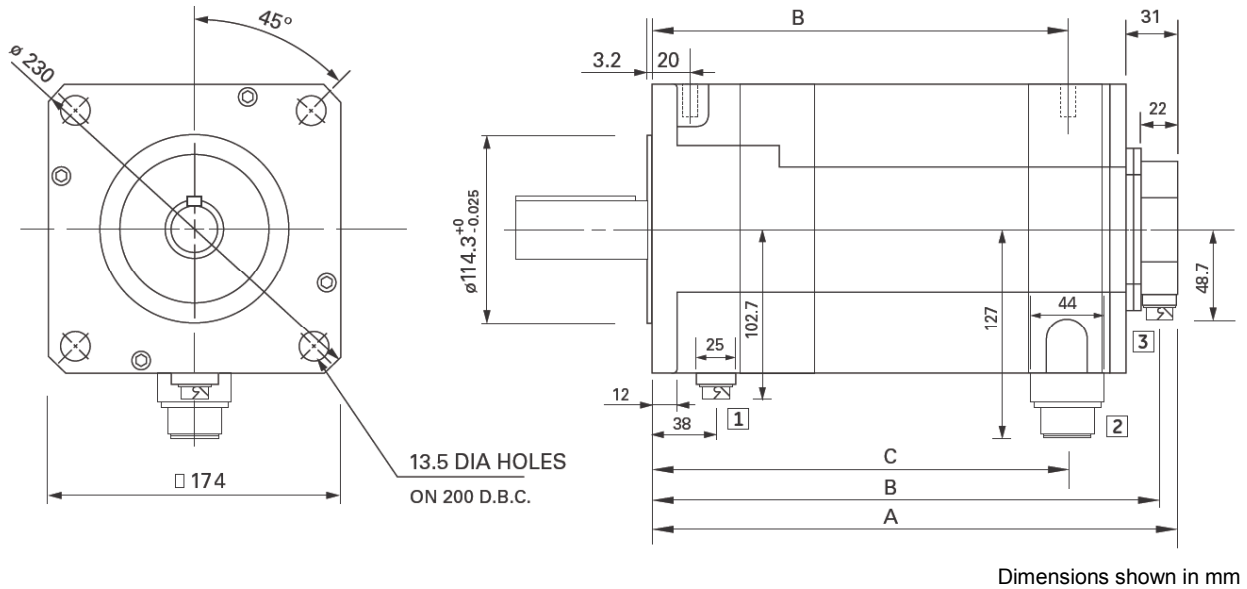

Figure IV-4. αHVi Series Servo Motor Speed-Torque Curves(α22/4000HVIs, α30/4000HVIs, α40/4000HVIs and α50/3000HVIs with Fan)

27.3 Motor Outline Drawings

ai Motor



Motor

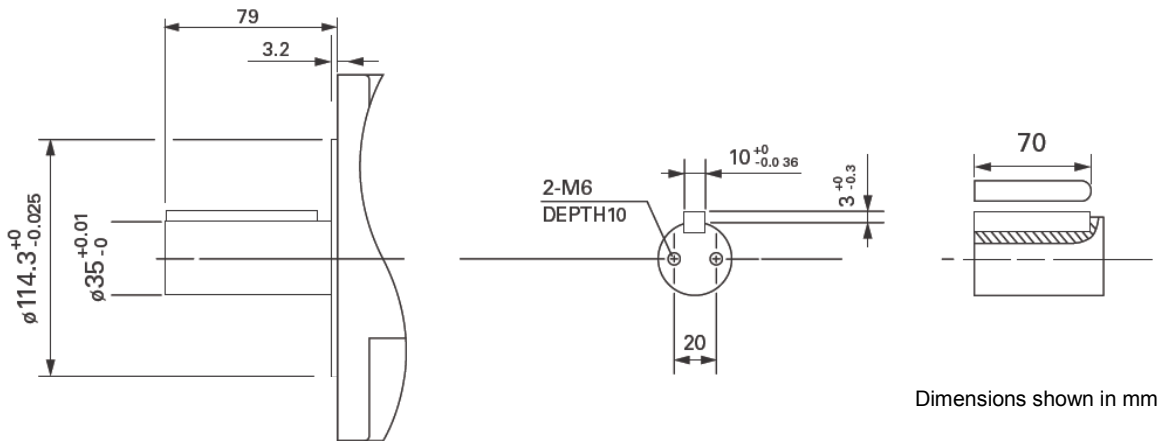

Shaft Detail

Dimension	$\alpha 22/3000i$	Connector	Description
A	276mm	1	Brake (optional)
A with brake	317mm	2	Power
B	265mm	3	Encoder
B with brake	306mm		
C	215mm		
C with brake	256mm		

Figure IV-5. ai Series Servo Motor Outline Drawing ($\alpha 22/3000i$)

Servo Products Specification Guide

*α*HVi Motors

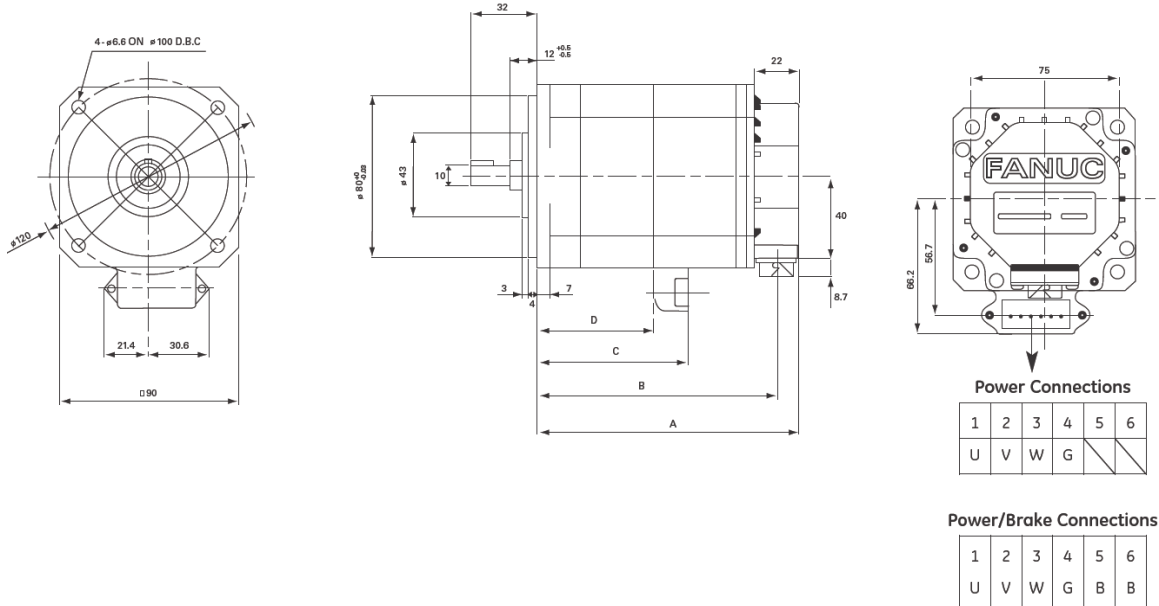

Motor

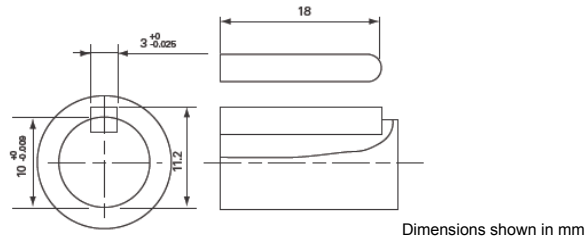

Shaft Detail

Dimension	<i>α</i> 2/6000HVis
A	130mm
A with brake	159mm
B	119mm
B with brake	148mm
C	75mm
C with brake	75mm
D	59mm
D with brake	59mm

Figure IV-6. *α*2/6000HVis Series Servo Motor Outline Drawing

Servo Products Specification Guide

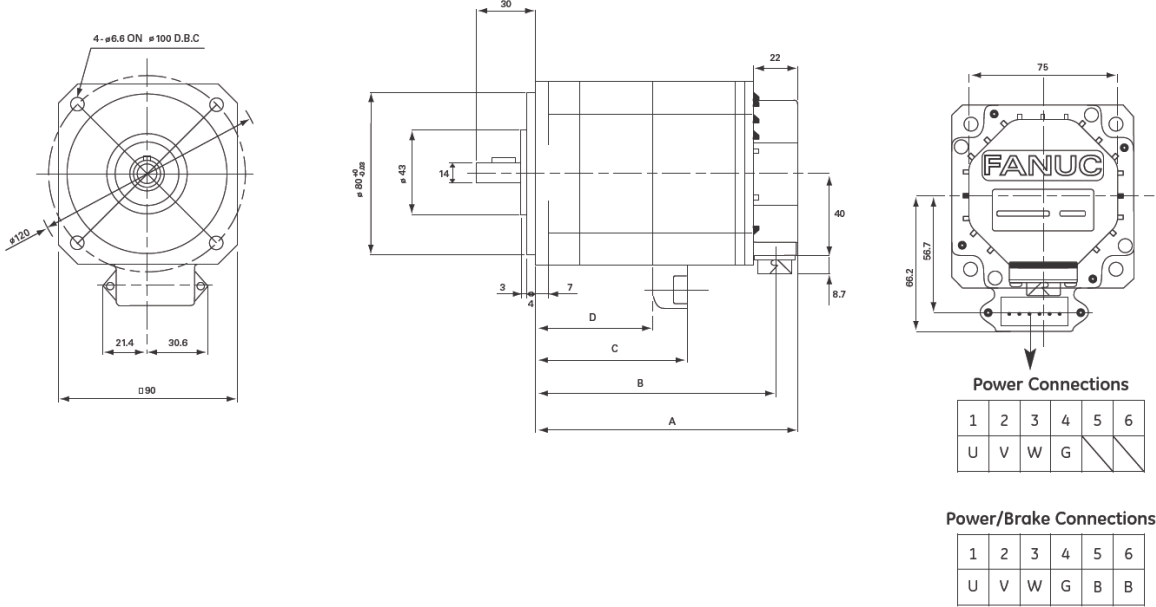

Motor

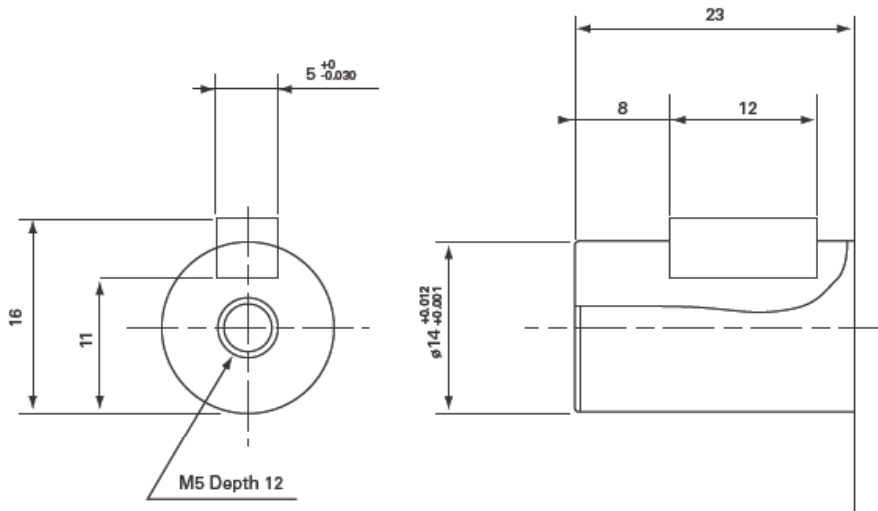

Dimensions shown in mm

Shaft Detail

Dimension	α4/5000HVis
A	166mm
A with brake	195mm
B	155mm
B with brake	184mm
C	111mm
C with brake	111mm
D	95mm
D with brake	95mm

Figure IV-7. α4/5000HVis Series Servo Motor Outline Drawing

Servo Products Specification Guide

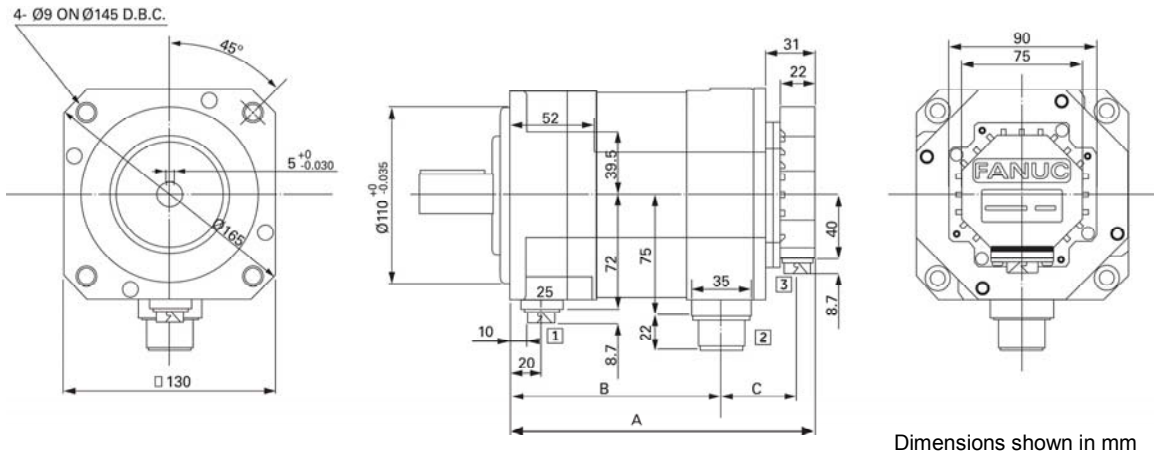

Motor

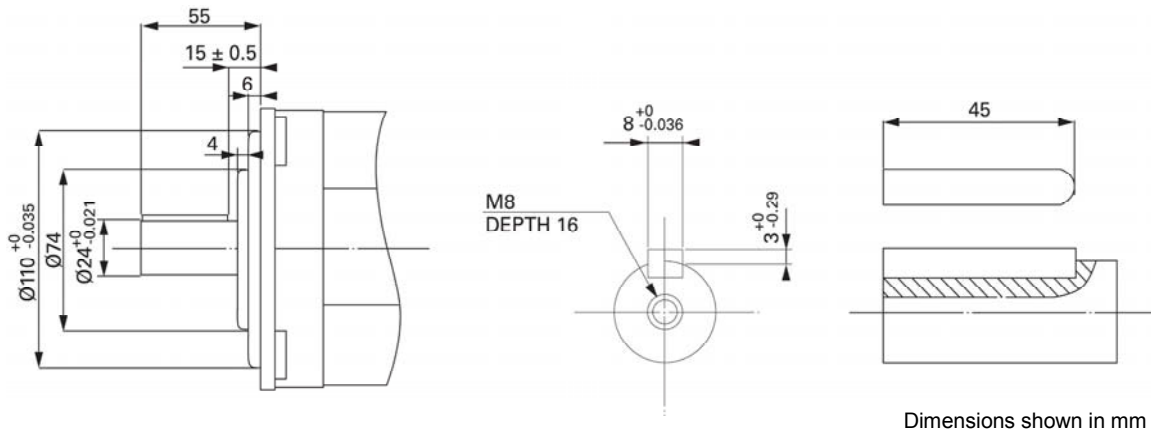

Shaft Detail

Dimension	$\alpha 8/6000HVis$	$\alpha 12/4000HVis$
A	166mm	222mm
A with brake	191mm	247mm
B	108mm	164mm
B with brake	133mm	189mm
C	47mm	47mm
C with brake	47mm	47mm

Connector	Description
1	Brake (optional)
2	Power
3	Encoder

Figure IV-8. $\alpha 8/6000HVis$ and $\alpha 12/4000HVis$ Series Servo Motor Outline Drawing

Servo Products Specification Guide

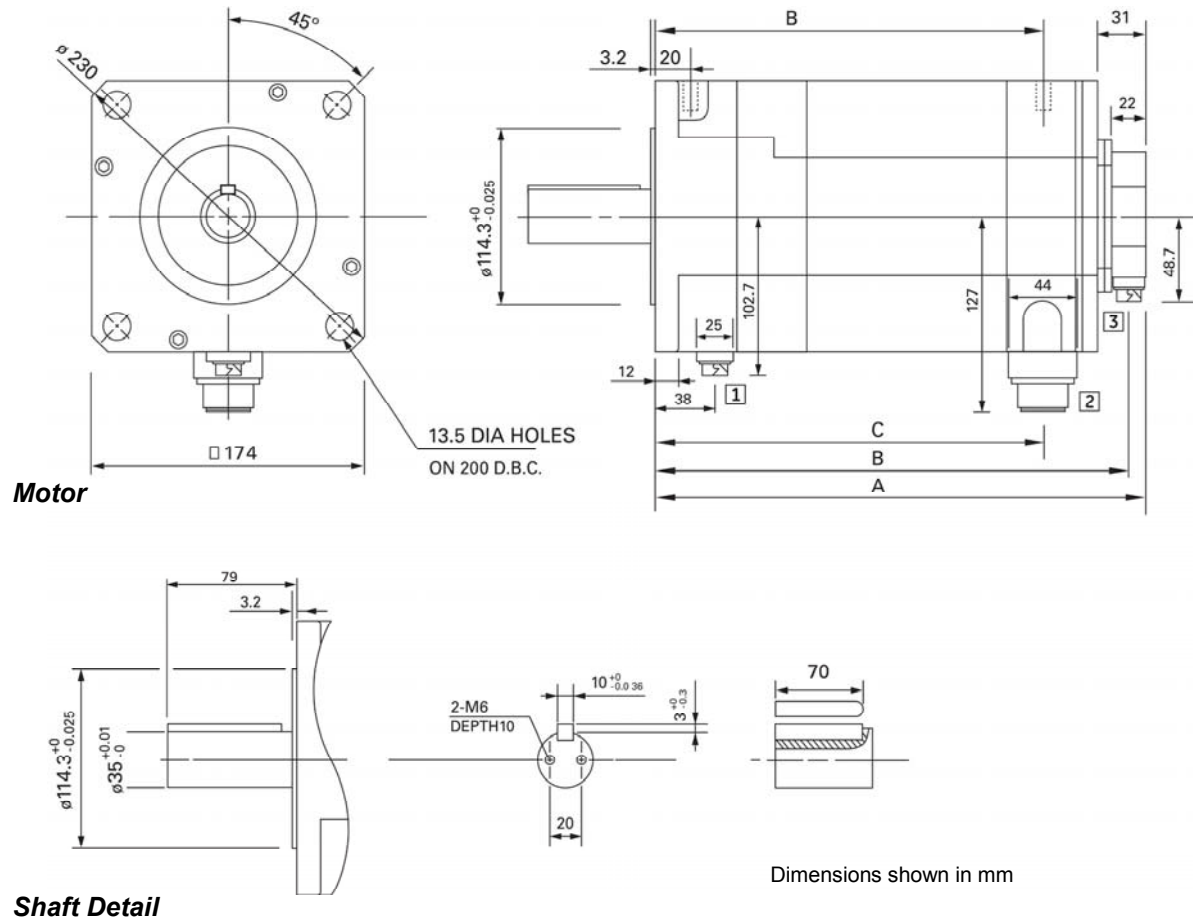

Dimension	$\alpha 22/4000HVis$	$\alpha 30/4000HVis$	$\alpha 40/4000HVis$
A	202mm	239mm	276mm
A with brake	243mm	280mm	317mm
B	191mm	228mm	265mm
B with brake	232mm	269mm	306mm
C	151mm	178mm	215mm
C with brake	182mm	219mm	256mm

Connector	Description
1	Brake (optional)
2	Power
3	Encoder

Figure IV-9. $\alpha 22/4000HVis$, $\alpha 30/4000HVis$, $\alpha 40/4000HVis$ Series Servo Motor (with Brake) Outline Drawing

Servo Products Specification Guide

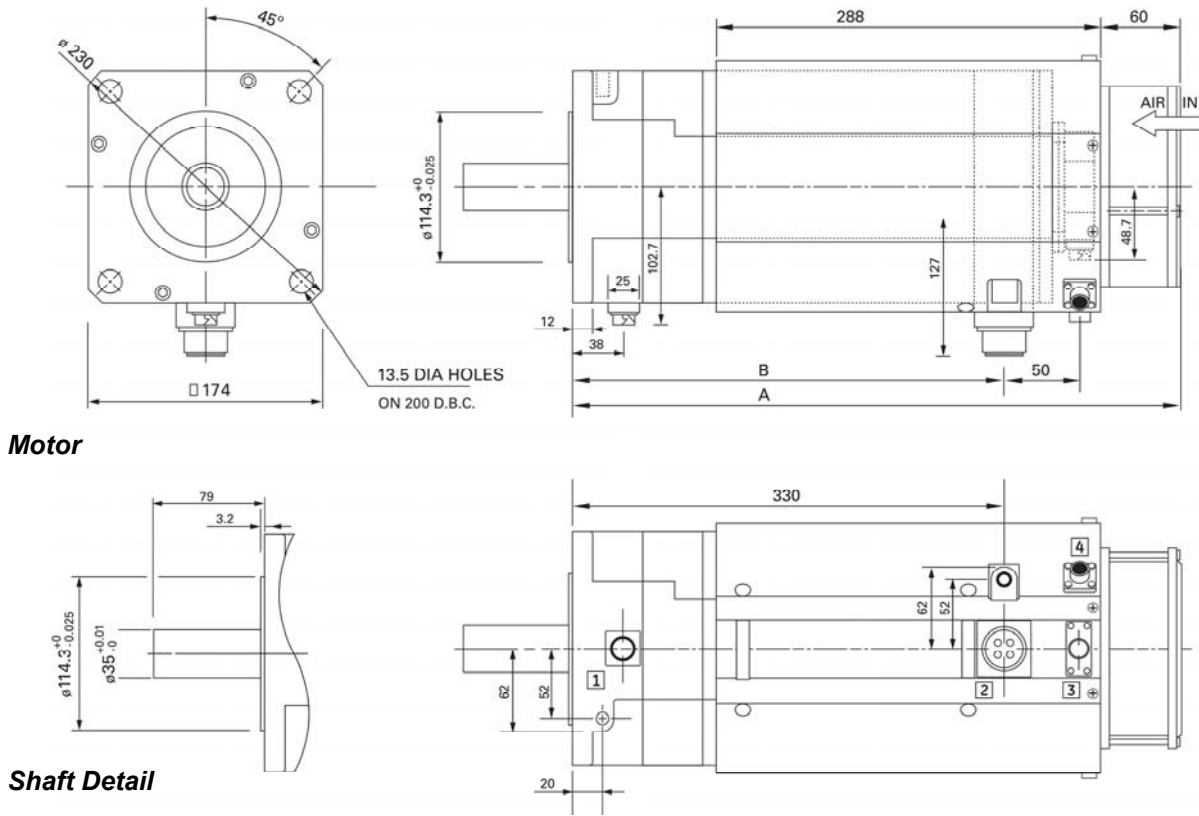

Motor

Shaft Detail

<i>Dimension</i>	<i>α50/3000Vis</i>	<i>Connector</i>	<i>Description</i>
A	416mm	1	Brake (optional)
A with brake	457mm	2	Power
B	289mm	3	Encoder
B with brake	330mm	4	Fan

Note: The motor does not include a circuit breaker for protecting the fan. Prepare such a circuit breaker in the power magnetics cabinet.

Figure IV-10. α50HV*is* Series Servo Motor with Fan Outline Drawing

27.4 Built-in Brake

The built-in holding brake is used to prevent movement on horizontal axes or falling along the vertical axis when the servo motor control is turned off. Brakes are spring-set and electrically released and are designed for holding stationary loads only. Using the holding brake to stop a moving axis may damage the brake or severely reduce its service life.

The specifications of the built-in brakes are listed in the following table.

Table IV-9. αi and $\alpha HVis$ Motor Holding Brake Specifications

Motor Model		Unit	$\alpha 2/6000HVis$, $\alpha 4/5000HVis$ $\alpha 8/6000HVis$	$\alpha 12HVis$	$\alpha 22i$, $\alpha 22HVi$, $\alpha 22HVis$, $\alpha 30HVis$, $\alpha 40HVis$, $\alpha 50HVis$ with fan
Brake Holding Torque		Nm	3	8	35
		lbf-in	26.6	70.8	309.8
Response Time	Release	msec	20	30	30
	Engage	msec	30	160	160
Power Supply	Voltage	VDC	24	24	24
	Current	A	0.9	1.1	1.2
	Power	W	22	26	29
Weight Increase		kg	1	2.2	6.0
Inertia Increase		kg-m ²	0.2	0.00007	0.0006
		lbf-in-s ²	1.77	0.0006195	0.00531

The values shown above are standard values at 20°C.

Brake Power Supply Circuit

The following table lists the recommended parts and their specifications to be used as components of a user-built brake circuit. Configure a brake circuit by referencing the following brake connection diagram and the recommended parts as shown below.

For brake connector details, refer to "Motor Connections" on page IV-19.

Table IV-10. ai and aHVi Holding Brake Circuit Components

Name	Model No.	Name of Manufacturer	Specifications
Rectifier*	D3SB60 ZA06B-6050-K112	Shindengen Electric Mfg. Co., Ltd.	Withstand voltage 400V min. Maximum output current: 2.3 A (with no fins)
Switch	N/A	N/A	Rated load capacity (resistance load) 250VAC 10A / 30VDC 10A or more
Spark Killer	XEB0471	Okaya Electric Ind. Co., Ltd.	47 ohm/0.1 μF Withstand voltage 400V min
Surge Absorber	ERZV10D820	Matsushita Electric Industrial Co., Ltd.	Varistor voltage 82V Max allowable voltage 50 VAC

* At an ambient temperature of 20°C, the temperature of the rectifier rises to about 60°C when one brake axis is used, or to about 90°C when two brake axes are used. Use a radiator fin as required.

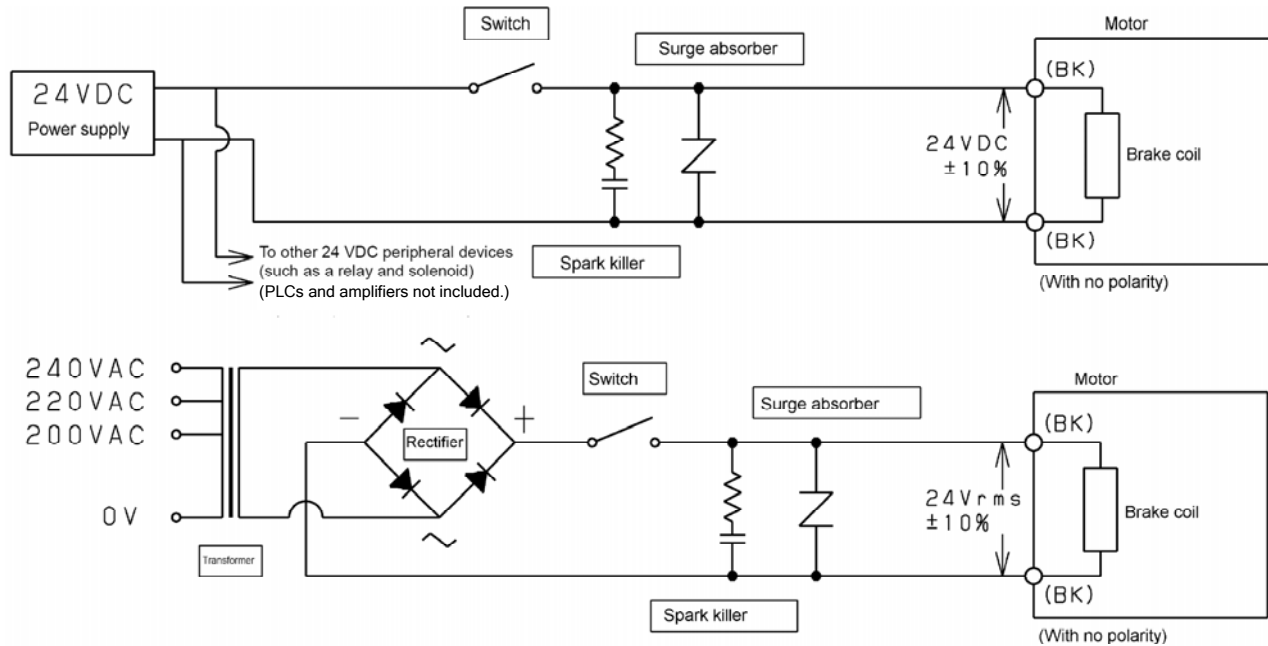

Figure IV-11. Connecting Motor Holding Brake Control and Power Circuit

Servo Products Specification Guide

1. Use a 24 VDC power supply as the power supply for the α i series servo motor brake. Power (equivalent to 24 Vrms) produced by full-wave rectification after transforming commercial power (50 Hz/60 Hz) is also available.
2. Use a power supply separate from the 24-V power supply for the amplifier as the power supply for the brake. If the control power supply is also used for the brake, an amplifier malfunction or another danger may occur. The power supply for a relay, solenoid, or another peripheral device can be used for the brake. Be careful of the power capacity and changes in voltage due to changes in load.
3. For full-wave rectification, transform the secondary side voltage obtained during energization of the brake into approximately 29VAC by taking voltage drop in the rectifier or cable into account.
In this case, check the power capacity and power voltage fluctuations sufficiently and then make sure the fluctuations of the voltage applied to the brake during energization falls within 24 Vrms \pm 10%. Switch the transformer's primary side input to a desired position such as 100-110-120 VAC or 200-220-240 VAC.
4. If the contact is installed on the DC side (at the position shown in the figure), the life of the contact is generally shortened due to the surge voltage at brake off. Provide an adequate contact capacity and always use a surge absorber and spark killer for protecting the contact.
5. You can use either positive or negative power pin to connect the brake because the brake coil is nonpolarized.
6. Use a shielded cable as required.

Caution

Observe the following precautions when motors with built-in brakes are used.

1. **A built-in brake is used as a holding brake to prevent a vertical axis from falling or a horizontal axis from being moved when torque is removed from the motor. This brake functions as a brake at an emergency stop or power failure, but should not be used to decrease the stop distance during ordinary deceleration.**
2. **The brake cannot be used to assist stopping the motor under servo control. This causes abnormal heating of the motor.**
3. **Match the timing of brake release (axis release) to the timing of servo on (motor energization) as much as possible. Similarly, match the timing of brake engagement to the timing of servo off as much as possible.**
4. **The total length of a motor with a built-in brake is much longer than that of the motor with no built-in brake. Be careful not to apply excessive force to the opposite side of the mounting flange or to apply excessive acceleration to the entire motor.**

27.5 Motor Connections

Table IV-11. α HVis Motor Connections

Power/Brake Connectors

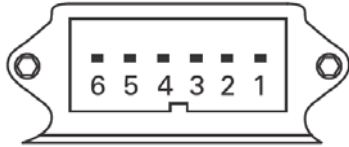

Description	Motor Connector	GE Intelligent Platforms Part Numbers	
		α 2HVis and α 4HVis	
1	U	Straight: ZA06B-6114-K220#S Right angle: ZA06B-6114-K220#E	
2	V		
3	W		
4	Ground (Motor Body)		
5	Brake VDC		
6	Brake VDC		

Power Connectors

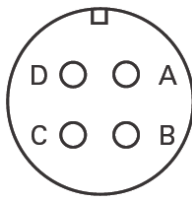

Description	Motor Connector	GE Intelligent Platforms Part Numbers	
		α 8HVis and α 12HVis	All others (except α 2HVis and α 4HVis)
U	A	Straight: Z44A730464-G17 Right angle: Z44A730464-G18	Straight: Z44A730464-G19 Right angle: Z44A730464-G20
V	B		
W	C		
Ground (Motor Body)	D		

Serial Encoder Connectors

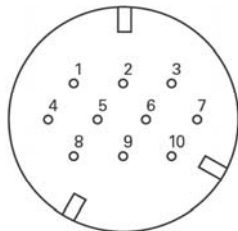

All α HVis, α HVi and α i Motors

Description	Motor Connector	Amplifier JF1 Connector	GE Intelligent Platforms Part Numbers
			All models
N/C	1	1—4, 8, 10, 11, 13, 15, 17—19	ZA06B-6073-K214
N/C	2		
RD	6	5	
*RD	5	6	
+5 VDC	8,9	9, 20	
0 VDC	7,10	12, 14	
+6 VA (battery)	4	7	
Frame Ground	3	16	
Cable Shield	3	16	

Servo Products Specification Guide

Brake Connector



α HVis, α HVi and α i Brake

		GE Intelligent Platforms Part Numbers
Description	Motor Connector	All models (except α2HVis and α4HVis)
Earth (case)	4	Right angle: ZA06B-6114-K213#E Straight: ZA06B-6114-K213#S
Brake VDC	1	
Brake VDC	2	
N/C	3	

Fan Connector



		GE Intelligent Platforms Part Numbers
Description	Motor Connector	α50/3000HVis w/ Fan
Earth (fan motor body)	4	Right angle: ZA06B-6114-K214#E Straight: ZA06B-6114-K214#S
Single-phase 200 VAC	1	
Single-phase 200 VAC	2	
N/C	3	

For information on connecting the fan, see page IV-21.

27.6 Cooling Fan

The α50/3000HVis servo motor includes a cooling fan.

Table IV-12. Cooling Fan Specifications

Input voltage	Single-phase 200 VAC	
	50 Hz	60 Hz
	170 to 220 VAC	170 to 242 VAC
Rated input	31W ±10%	30W ±10%
Rated current	0.23A ±10%	0.2A ±10%
Degree of protection (IEC34-5)	IP00	

Connecting the Fan Power

Manufacturer: Japan Aviation Electronics Industry

Manufacturer specification: JN2AS04MK2X-R

GE Intelligent Platforms Part Numbers:

ZA06B-6114-K214#E (right angle)

ZA06B-6114-K214#S (straight)

This connector is not drip-roof.

The shape and pin layout of the connector are shown below.

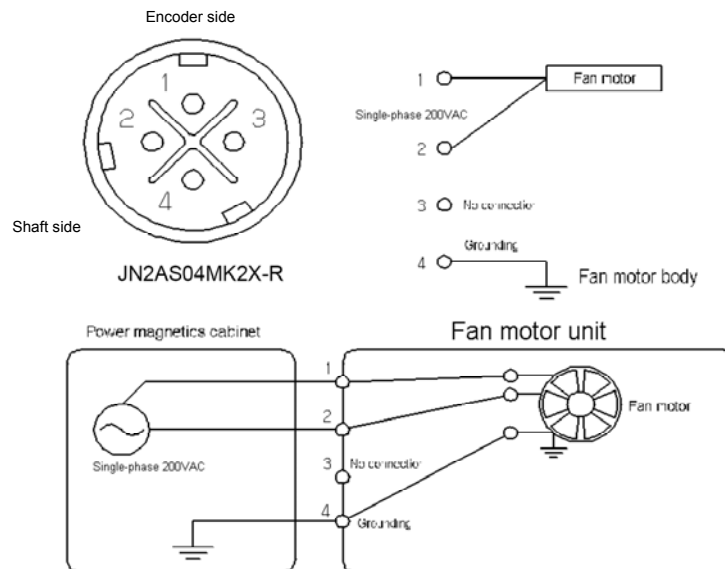

Section 28: α SVM1 Amplifiers

28.1 Amplifier Specifications

Table IV-13. α SVM1 Series Amplifier Electrical Specifications

Item	α SVM1-10HV <i>is</i>	α SVM1-40HV <i>i</i>	α SVM1-80HV <i>i</i>	α SVM1-180HV <i>i</i>
Type	60mm-wide with external fin	60mm-wide with external fin	60mm-wide with external fin	150mm-wide with external fin
Power Supply Voltage (amplifier)	3-Phase 400–480VAC			
Power Supply Voltage (control)	Single-phase 200VAC to 240VAC (input from connector CX1A)			
Allowable Voltage Deviation	-15% to +10% (including voltage variation due to load)			
Power Frequency	50/60Hz, \pm 1Hz			
Power Supply Imbalance	\pm 5% of the rated voltage or less			
Power Supply Impedance	The voltage variation must be within \pm 7% when a maximum output is produced for voltage at non-load time (power running and regeneration).			
Dynamic Brake Module	NA	NA	NA	ZA06B-6079-H401
Short Circuit Current Rating (SCCR)	85KA	85KA	85KA	85KA

Table IV-14. α HVi Series Amplifier Environmental Specifications

Item	Specification
Ambient Temperature Operation Storage	0 to 55 °C -20 to 60 °C
Humidity	90% RH or below (non-condensing)
Vibration	Below 0.5 G

28.2 α HVi Series Amplifier Status LED and Alarm Functions

The servo amplifier unit can detect error conditions and provide alarm information.

The LEDs on the front of the amplifier provide a visual indication of system status by indicating, for example, when the motor and amplifier are ready to function.

- POWER LED (green) indicates the logic 24 VDC power is present.
- DC LINK CHARGED LED (red) indicates that the amplifier has high (motor) voltage DC present.
- LINK LED (green) indicates that the FSSB (fiber optic) interface is functioning.
- ALM LED (yellow) is turned ON when an alarm condition is detected. When an alarm is detected, power is dropped and the motor is stopped by dynamic braking action. Alarm information is additionally displayed as diagnostic data in the DSM324i motion controller. The amplifier control power must be cycled to reset this alarm state. The table below details the alarm conditions the α i Series Servo Amplifier can detect.

Servo Products Specification Guide

Table IV-15. α HVi Series Servo Amplifier Alarms

Alarm Condition	Description
DC Link Under-Voltage	Issued when the DC voltage in the main circuit power supply is abnormally low. Indicates low AC mains power dip or hardware problem. Make sure the plug-in (gray faceplate) circuit board is securely seated in the amplifier base. Replace amplifier.
DC Link Over-Voltage	Issued when the DC voltage in the main circuit power supply is abnormally high. Indicates high AC mains power or hardware problem. Make sure the plug-in (gray faceplate) circuit board is securely seated in the amplifier base. May also be caused by excessive regenerated power. Increase acceleration/deceleration time and/or add additional regenerative discharge capacity. Replace amplifier.
Excessive Deceleration Power	<p>If no external regeneration resistor is used, the discharge resistor thermal sensor jumper is missing on connector CXA20. This input requires a normally closed contact for normal operation.</p> <p>When using an external regeneration resistor, the thermal sensor in the regeneration resistor has tripped. Indicating excessive regenerated power load to the regeneration resistor. Use a meter to confirm an open circuit on the thermal sensor leads. Make sure the plug-in (gray faceplate) circuit board is securely seated in the amplifier base. Increase capacity of external regeneration resistor or decrease deceleration rate or frequency, and/or the top speed from which the axis must decelerate.</p>
Control Power Under-Voltage	The 24 VDC control power is below 21.6 VDC. Check the supply voltage level and make sure the CXA19A and CXA19B connectors are secure and associated cables are wired correctly. Replace amplifier.
Internal Cooling Fan Stopped	Fan is jammed, has failed or is not connected. Check for foreign material in fan blades. Make sure fan is plugged in. Make sure the plug-in (gray faceplate) circuit board is securely seated in the amplifier base. Replace amplifier.
IPM Alarm	Excessive current in the power transistors. Phase to phase or phase to ground short circuit on motor power output. Make sure the plug-in (gray faceplate) circuit board is securely seated in the amplifier base. Possible incorrect phase connection of the motor power wiring. Motor type code must be configured correctly in the GE Intelligent Platforms controller. Disconnect motor power leads from amplifier and reset E-stop condition. If IPM alarm occurs replace amplifier. If no IPM alarm the problem is in the motor or motor power cable. Check for electrical shorts in the motor power cable or motor winding shorted to frame ground.
IPM Overheat	Issued when the temperature inside the amplifier becomes so high that the thermostat trips. Make sure the plug-in (gray faceplate) circuit board is securely seated in the amplifier base. Check that the heat sink cooling fan (if applicable) is running. Make sure the ambient temperature around the amplifier is 55°C or lower. Check that the motor load is within the rating of the motor.
Motor Over-current	Issued when an abnormally high current is detected in the main circuit. Make sure the plug-in (gray faceplate) circuit board is securely seated in the amplifier base. Check for electrical shorts in the motor power cable or motor winding shorted to frame ground. Possible incorrect phasing on motor power wiring. Motor type code may be configured incorrectly in the DSM324i or PACMotion controller. Possible excessive force loading on motor.
FSSB Communication Error	FSSB connector or cable failure. Check the connections to the COP10A and COP10B connectors. Try replacing the optical cable. Replace amplifier.

28.3 Amplifier External Dimensions

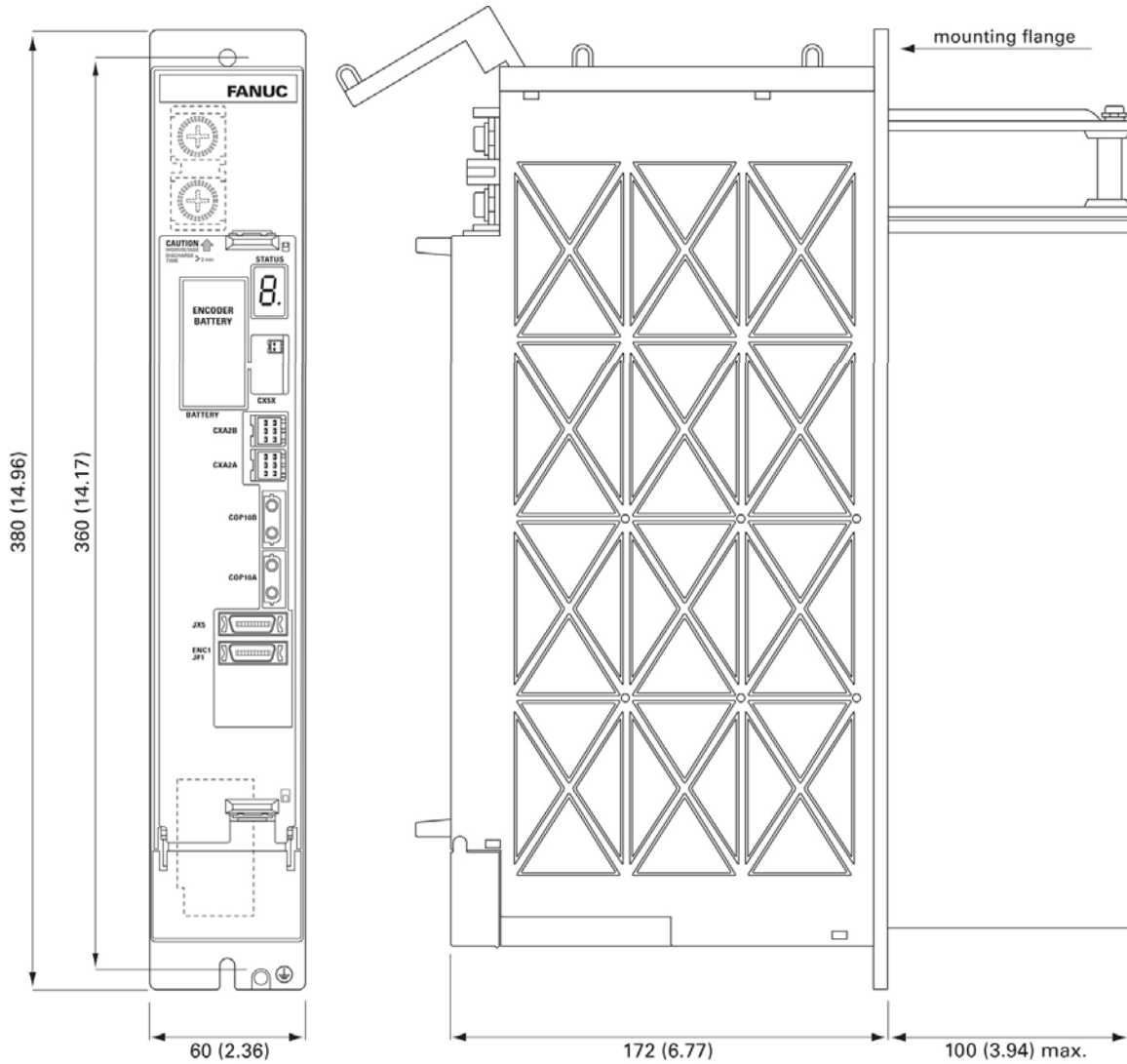

Figure IV-12. External Dimensions of α SVM1-10HVi, α SVM1-40HVi and α SVM1-80HVi Amplifiers

Servo Products Specification Guide

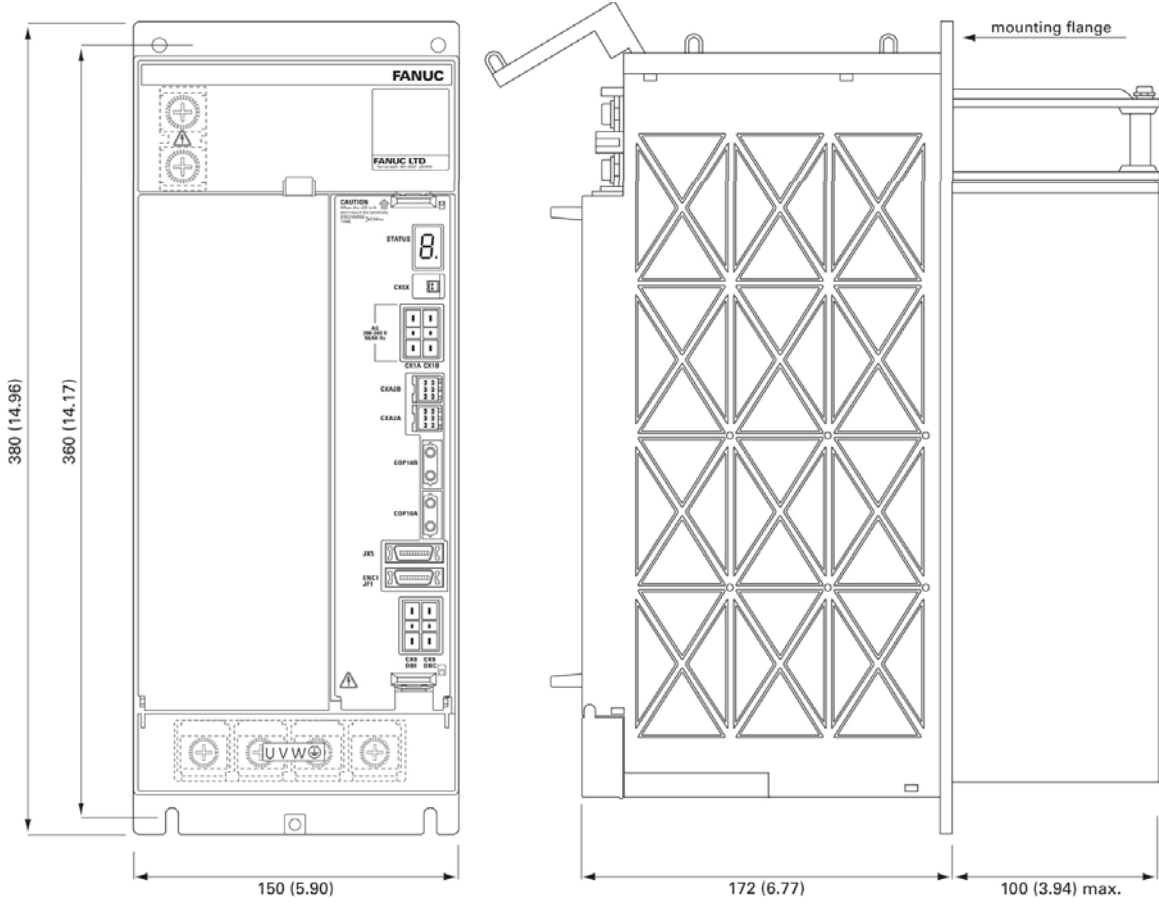

Figure IV-13. External Dimensions of α SVM1-180HVi Amplifier

28.4 Dynamic Braking Module Dimensions

The SVM1-180i requires a dynamic brake module (DBM), ZA06B-6079-H401. The DBM is used to immediately stop the motor at emergency stop or during servo alarms. Other amplifiers contain a similar function.

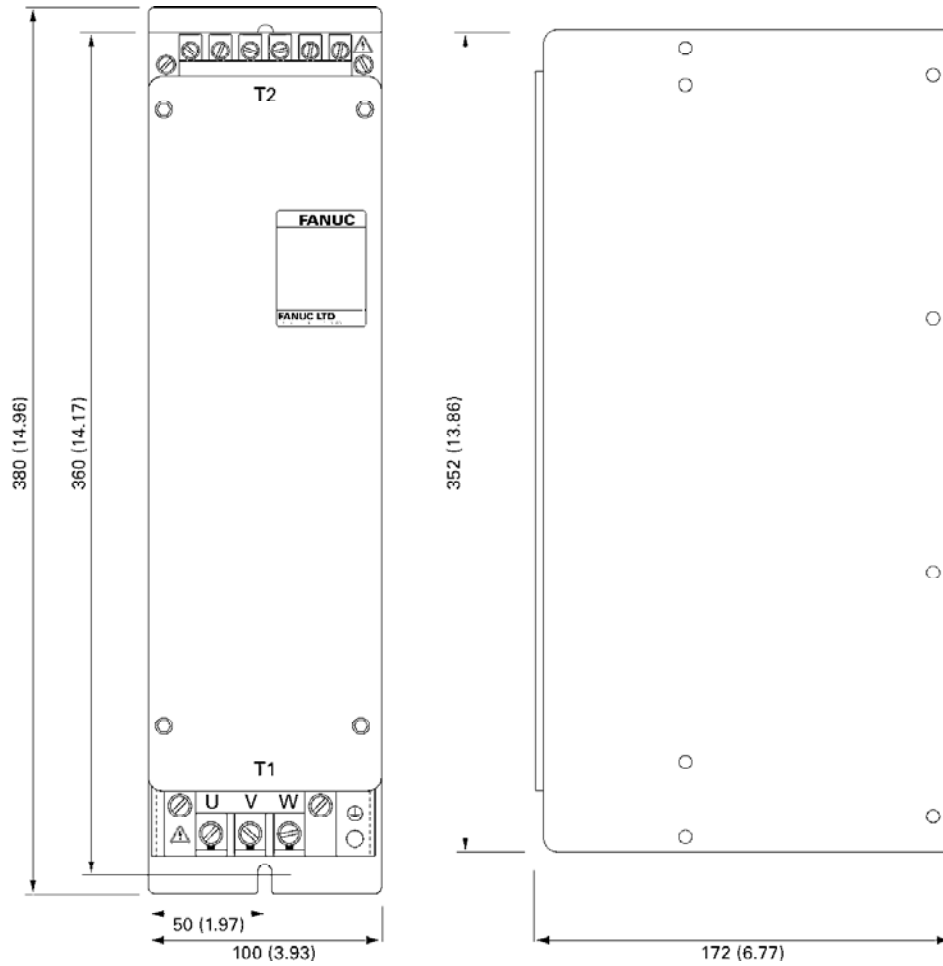

Figure IV-14. Dynamic Braking Module Outline Drawing

28.5 Power Supplies

Four power supply modules, PSM-11HVi, PSM-18HVi, PSM-30HVi and PSM-45HVi, are available for use with the α HVis Series servo system.

A maximum of six SVM1 amplifiers can be connected to a power supply, provided the output capacity conditions listed in the following table are not exceeded.

Table IV-16. 400V Input Power Supplies

Specification	PSM-11HVi ZA06B-6150-H011	PSM-18HVi ZA06B-6150-H018	PSM-30HVi ZA06B-6150-H030	PSM-45HVi ZA06B-6150-H045
Rated Output Capability	11kW	18kW	30kW	45kW
Maximum Output Capability	20kW	35kW	60kW	85kW
Peak Output Capability	34kW	58kW	87kW	124kW

Power Supply Dimensions

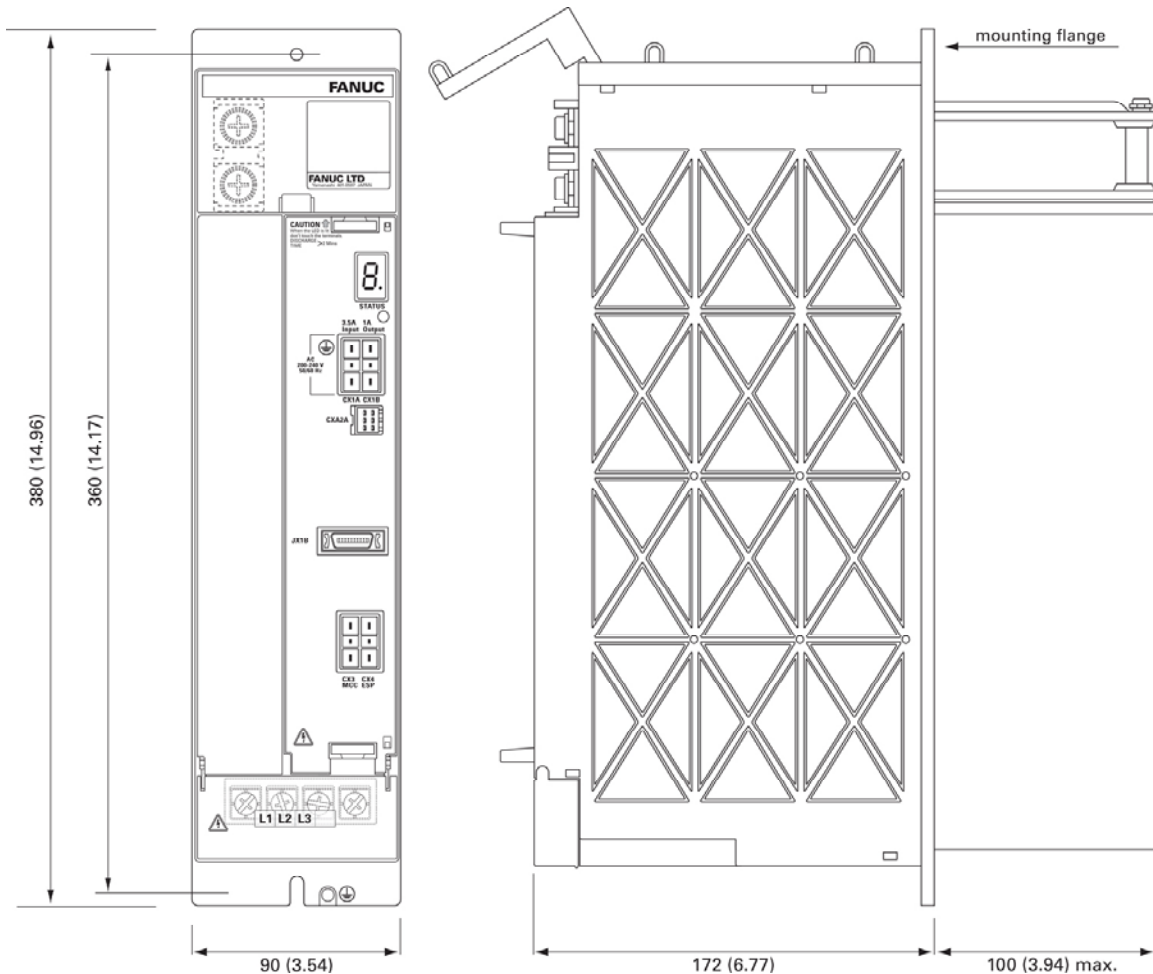

Figure IV-15. Power Supply Modules PSM-11HVi and PSM-18 HVi Outline Drawing

Servo Products Specification Guide

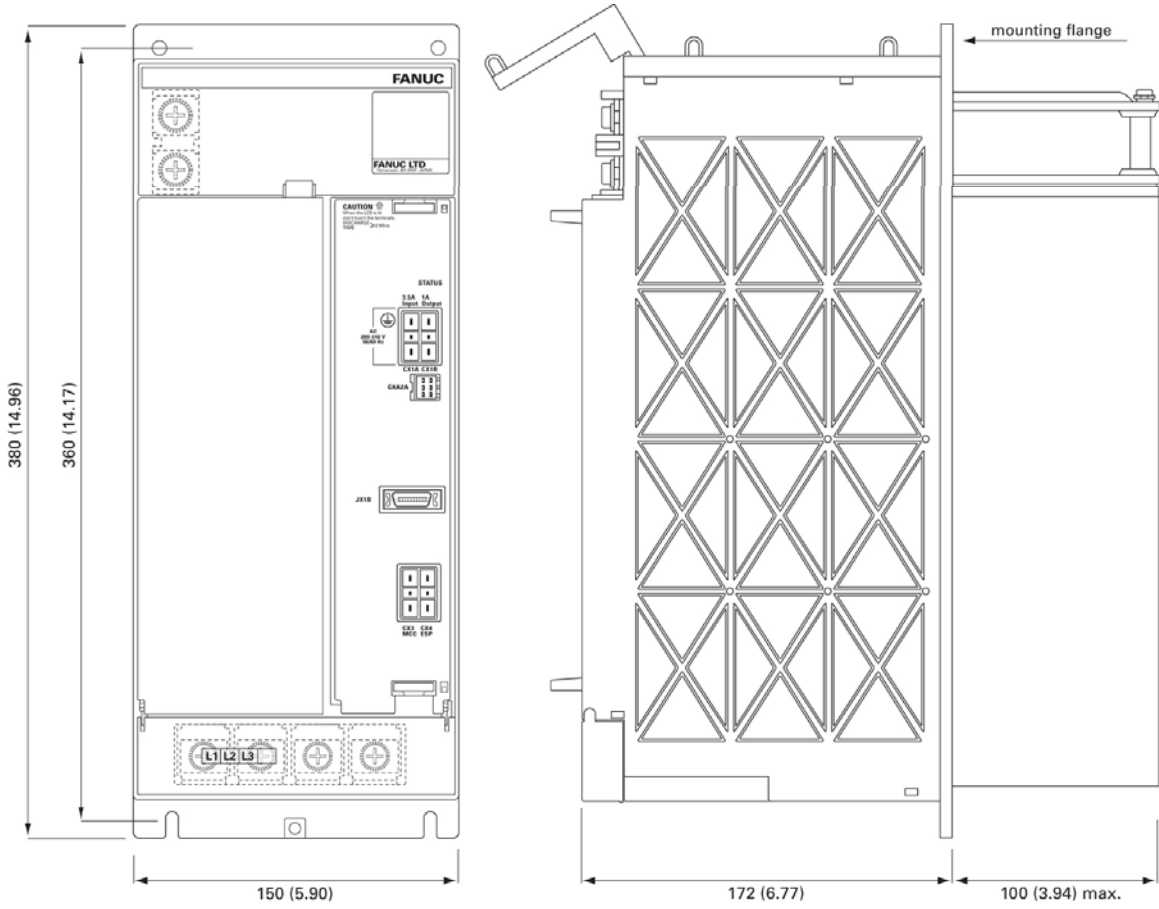

Figure IV-16. Power Supply Modules PSM-30HVi and PSM-45 HVi Outline Drawing

28.6 Absolute Encoder Battery Options

The α i, α HVi and α HVis Series servomotors feature a built-in absolute encoder that requires an encoder battery pack. This pack allows the encoder's position information to be maintained so that the machine does not need to be re-referenced to a home position every time power is restored to the servo system.

The encoder contains an integral capacitor that will maintain the encoder backup voltage for approximately 10 minutes. This allows battery change without loss of absolute position data.

There are two encoder battery backup options for the α HVi Series amplifiers:

- a snap-on lithium battery pack that will support a single amplifier
- a panel mounted battery pack for up to four amplifiers that uses standard D cell alkaline batteries.

Table IV-17. Battery Kits and Accessories

Battery Kits and Accessories	αSVM1-40HVi and αSVM1-80HVi	αSVM1-180HVi
Panel Mounted Encoder Battery Kit	IC800ABK001	IC800ABK001
Built-in Lithium Encoder Battery Kit*	IC800ABK002	IC800ABK003
Lithium Battery Pack	ZA06B-6114-K504	ZA06B-6114-K504
Battery Holder	ZA06B-6114-K505	ZA06B-6114-K506

* Includes the lithium battery pack and battery holder. Replacement battery packs can be ordered separately.

Battery Connection Method for Single Amplifiers

For optimal panel space utilization, a small lithium battery pack IC800ABK002 or IC800ABK003 is available that snaps onto the amplifier housing (see figure below). An integral pigtail cable plugs directly into the CX5X connector on the faceplate of the amplifier. One battery is required for each amplifier. The lithium battery service life is approximately two years.

Installation

1. Make sure 24V control power is applied to the amplifier (if trying to hold position on an existing system).
2. Place system in an E-stop condition.
3. Remove AC power from the amplifier.
4. Remove the old battery (if applicable).
5. Place battery into plastic cover.
6. Snap cover onto amplifier housing.
7. Attach battery cable to amplifier CX5X connector as indicated in diagram making sure polarity is correct.

Notes:

- Do not attempt to connect multiple amplifiers to one IC800ABK002 or IC800ABK003 battery kit.
- Replacement CX5 battery connectors are available as kit number ZA06B-6093-K303

Servo Products Specification Guide

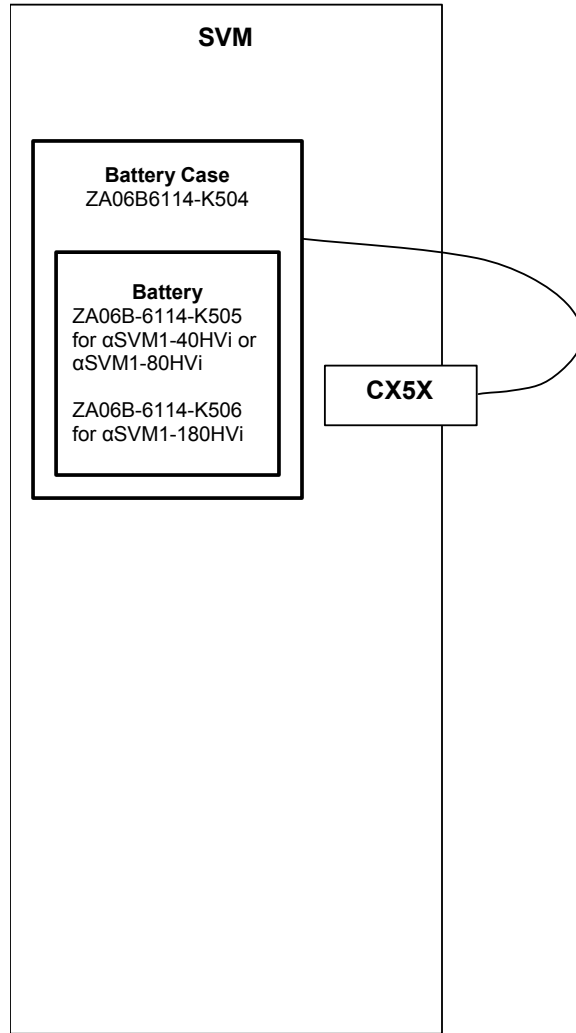

Figure IV-17. Installing the Absolute Encoder Battery Pack (One-Axis)

Connection Method for Multiple Amplifiers

To utilize the absolute capability for multiple amplifiers, the IC800ABK001 panel mounted battery pack must be installed.

The Absolute Encoder Battery Kit (IC800ABK001) contains the following:

- One battery holder (ZA06B-6050-K060)
- Four D-cell, alkaline batteries (ZA98L-0031-0005)

One kit provides battery backup for up to four absolute encoders. The user is responsible for manufacturing the cable used to connect the battery pack to the amplifier. The battery connection is made to the CXA2A connector on the last amplifier in the sequence supported by the battery pack. Terminals CXA2A-B3 (6V) and CXA2A-A2 (0V) are used and wire should be 0.3 mm² minimum cross sectional area. The battery power is distributed to the other amplifiers in the sequence by daisy chaining the CXA2B connections to the CXA2A connections on adjacent amplifiers. See Section 33: aHVi Series Servo System Connection for more detail.

The battery service life is approximately one year and we recommend a yearly replacement schedule.

The IC800ABK001 battery pack is panel-mounted and requires a cutout in the mounting surface. Mounting dimensions and terminal designations are shown below.

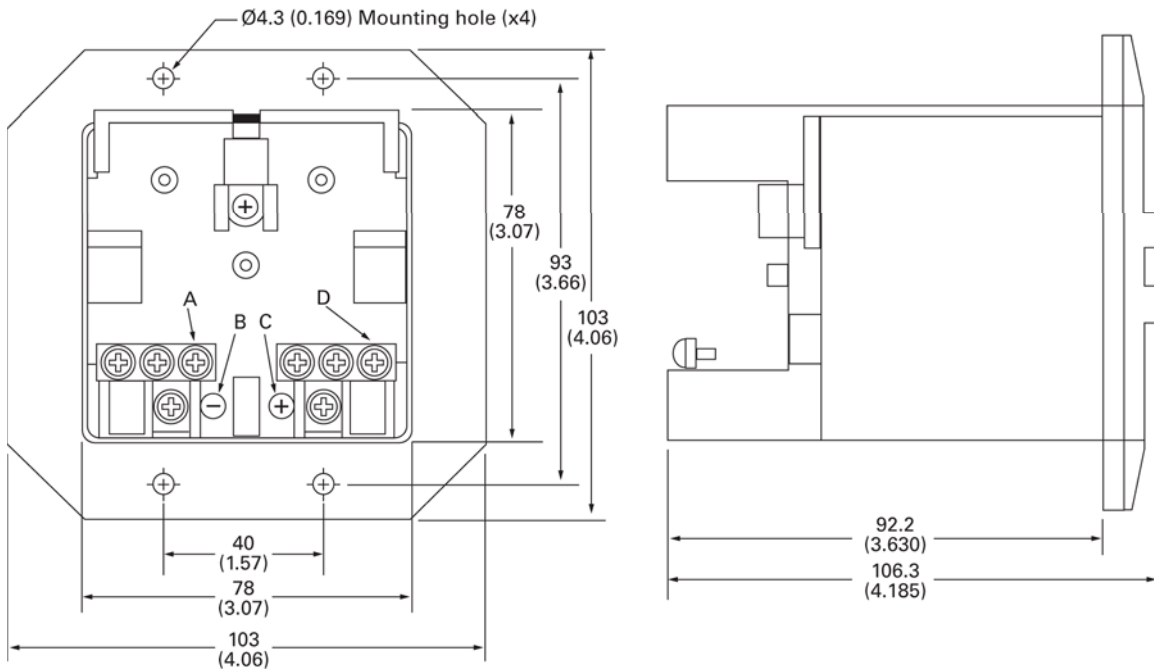

All dimensions in mm (in.)

A	3-M3 negative terminal
B	Negative terminal indication
C	Positive terminal indication
D	3-M3 positive terminal
E	4- $\varnothing 4.3$ (0.169) mounting holes

Figure IV-18. Absolute Encoder Battery Pack IC800ABK001 (up to Four Axes)

Section 29: Installation Guidelines

This section includes environmental requirements, motor and amplifier dimension drawings and information on ensuring noise protection and selecting a ground fault interrupter.

29.1 αi , αHVi and $\alpha HVis$ Motor Environmental Requirements

The servomotor must be installed in a location that satisfies the following environmental conditions:

Table IV-18. Servo Motor Environmental Conditions

Condition	Description
Ambient temperature	0°C to 40°C When operating the motor at a temperature higher than 40°C, it is necessary to de-rate the output power so that the motor's and the encoder's temperature rating is not exceeded.
Ambient humidity	Should be 80% relative humidity or less, non-condensing
Vibration	When installed in a machine, the vibration applied to the motor must not exceed 5G.
Altitude	Up to 1,000 meters (3,300 ft) above the sea level requires no particular provision for attitude. When operating the machine at a higher level, the maximum operating temperature should be lowered 1°C for every 100m higher than 1,000m. For example, when the machine is installed at 1,500 meters above sea level, the ambient temperature should be 35°C or less.
Drip-Proof Environment	The motors have a drip-proof structure that complies with IP65 of the IEC standard. Nevertheless, to ensure long-term performance, the motor surface should be protected from solvents, lubricants, and fluid spray. A cover should be used when there is a possibility of wetting the motor surface. Also, to prevent fluid from being led to the motor through the cable, put a drip loop in the cable when the motor is mounted. Finally, turn the motor connector sideways or downward as far as possible. If the cable connector will be subjected to moisture, it is recommended that an R class or waterproof plug be used. For additional information, see <i>Servo and Spindle Motors Exposed to Liquids</i> , GFK-1046.

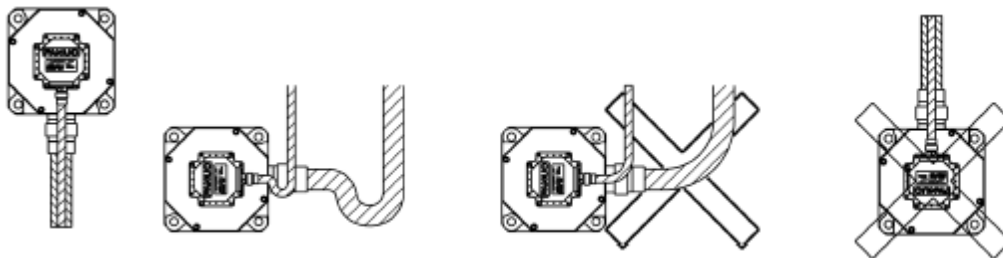

Figure IV-19. Motor Installation for Drip-Proof Environment

29.2 α HVi Servo Amplifier Environmental Requirements

The servo amplifier must be installed in a location that satisfies the environmental conditions identified in the table below.

Table-19. Servo Amplifier Environmental Conditions

Condition	Description
Ambient temperature	Operating: 0°C to 55°C (operating). See temperature derating curves below. Storage and transportation: -20°C to 60°C Outside cabinet: 0°C to 45°C
Temperature fluctuation	Within 1.1°C/min.
Humidity	90% relative humidity (non-condensing) or lower.
Altitude	No more than 1000 m (3,300 ft) above sea level.
Vibration	No more than 0.5 G during operation.
Atmosphere	The circuitry and cooling fins must not be exposed to corrosive or conductive vapor or liquid.

Temperature Derating

Consider derating as shown below, according to ambient operating temperatures.

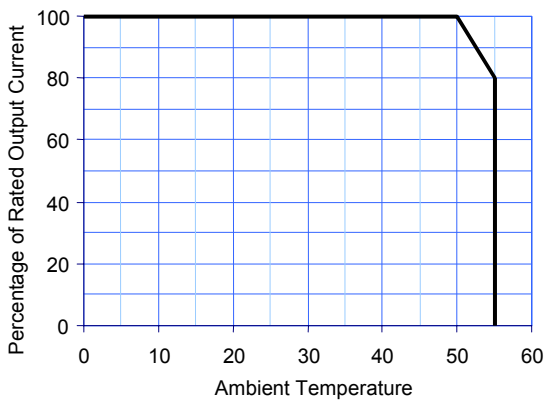

αSVM1-40HVi and αSVM1-80HVi Amplifiers

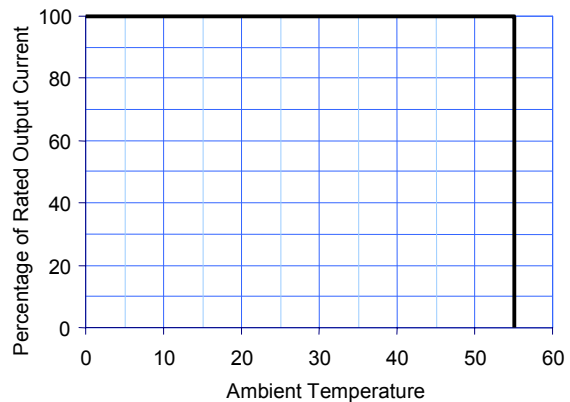

αSVM1-180HVi Amplifiers

Figure IV-20. Temperature Derating

Cabinet Installation

The amplifier must be installed in a cabinet that protects it from contaminants such as dust, coolant, organic solvents, acid, corrosive gas, and salt. Adequate protection must also be provided for applications where the amplifier could be exposed to radiation, such as microwave, ultraviolet, laser light, or x-rays.

To adequately protect the amplifier, you must ensure that:

- Contaminants such as dust and fluid cannot enter through the air inlet or outlet.
- The flow of cooling air is not obstructed.
- The amplifier can be accessed for inspection.
- The amplifier can be disassembled for maintenance and later reinstalled.
- There is sufficient separation between the power and signal lines to avoid interference. Noise protection should be provided.

Note: Attach the accompanying gasket around the panel cutout to prevent oil and dust from getting in. Reinforce the right and left sides of the panel cutout by using fittings such as angles to maintain satisfactory contact between the cabinet and the amplifier.

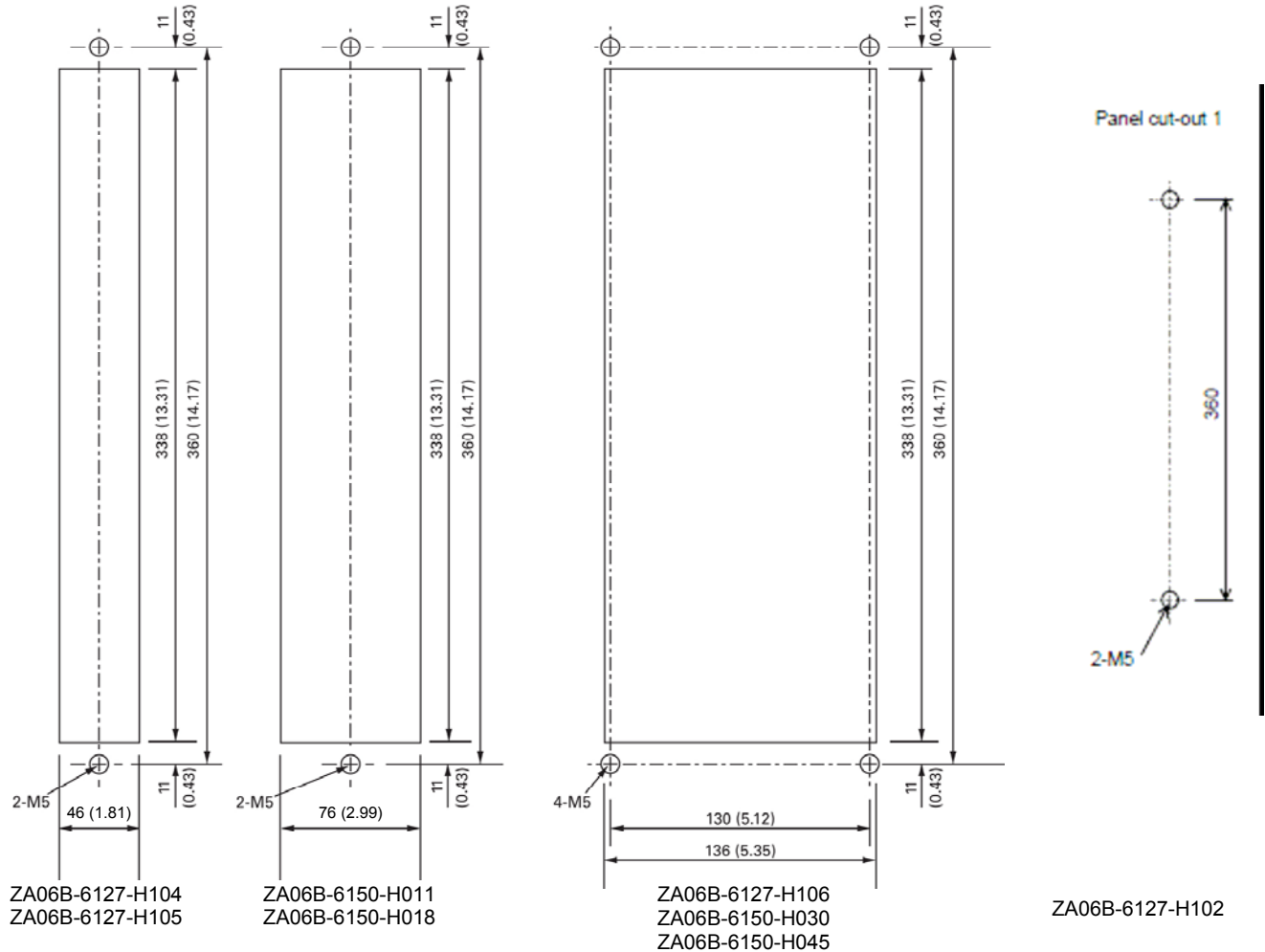
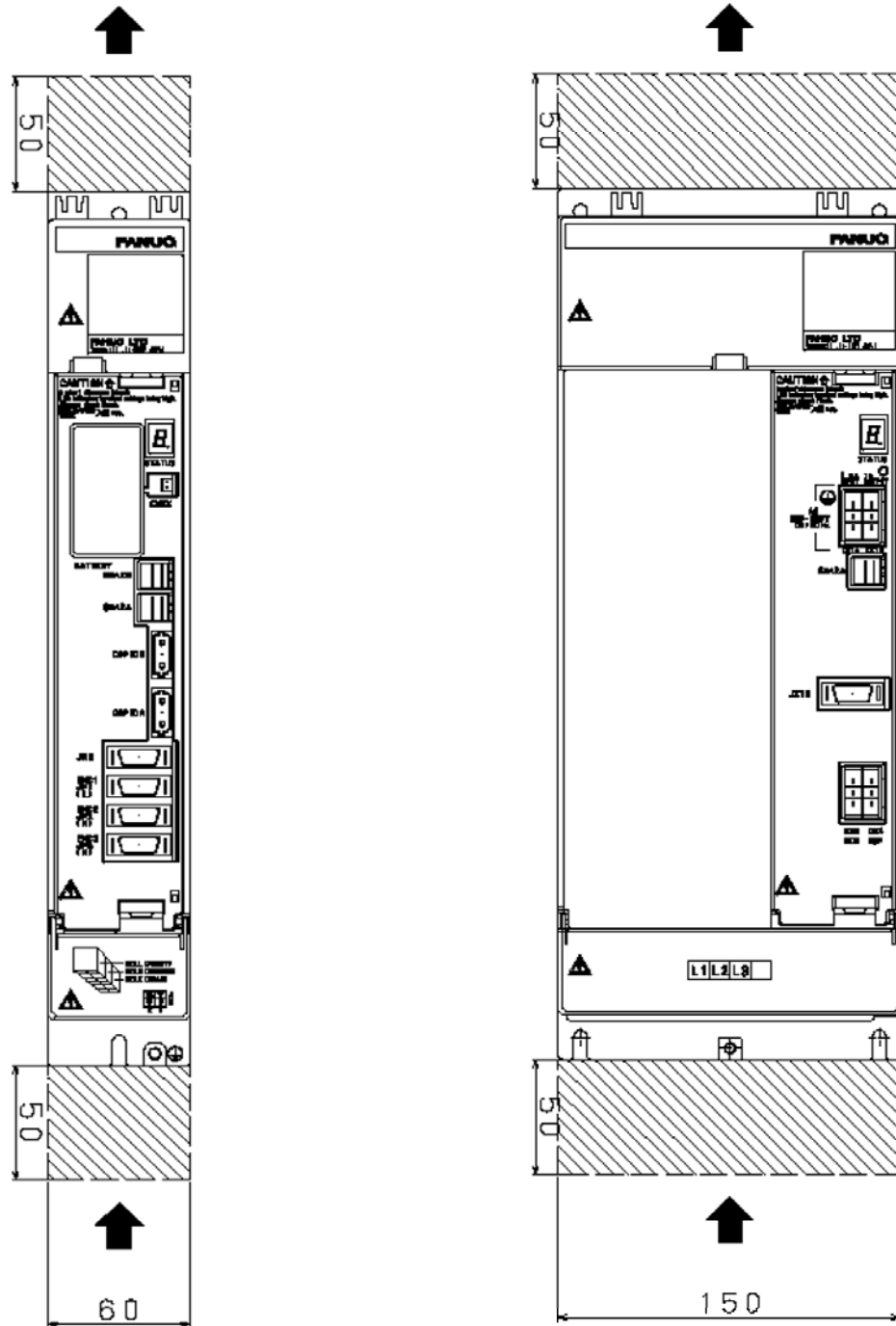

Figure IV-21. αHV_i Amplifier Maintenance Clearances (dimensions shown in mm)

29.3 Amplifier Heat Dissipation and Maintenance Clearance

The amplifier may contain a cooling fan that forces air through the unit. Allow for adequate clearance for airflow when installing the amplifier using the recommended distances shown in the drawings below. If possible, do not mount amplifiers one above the other unless they are staggered to prevent the heated exhaust of the lower unit from flowing over the upper unit.



alphaSVM1-40HVi and alphaSVM1-80HVi Amplifiers

alphaSVM1-180HVi Amplifier

Figure IV-22. Alpha Amplifier Maintenance Clearances (dimensions shown in mm)

Section 30: Heat Dissipation

Table IV-20 identifies worst-case heat dissipation values for each amplifier. These values may be used to determine heat load for sizing enclosures and cooling equipment.

The total heat dissipation is a function of the amplifier base dissipation (a) plus the amplifier heat coefficient (K) times the heat generated by RMS stall current flowing through the servo motor (b).

Total heat dissipation, Watts = a + (K * b)

Table IV-20. In Cabinet Heat Dissipation

<i>Amplifier</i>	<i>Catalog #</i>	<i>Amplifier base heat dissipation (a)</i>	<i>Amplifier heat coefficient (K)</i>	<i>Motor Model</i>	<i>Motor Current (b) [Arms]</i>	<i>Total heat dissipation [Watts]</i>
αSVM1-40HVi	ZA06B-6127-H104	13 watts	8.8 (heat sink in cabinet)	α12/4000HVis	6.7	71.9
				α22/3000HVis	9.1	93.0
			1.76 (heat sink external to cabinet)	α12/4000HVis	6.7	24.8
				α22/3000HVis	9.1	29.0
αSVM1-80HVi	ZA06B-6127-H105	17 watts	9.0 (heat sink in cabinet)	α22/4000HVis	15.5	156.0
				α30/4000HVis	15.9	160.0
				α40/4000HVis	18.1	180.0
			0.90 (heat sink external to cabinet)	α22/4000HVis	15.5	31.0
				α30/4000HVis	15.9	31.3
				α40/4000HVis	18.1	33.3
αSVM1-180HVi	ZA06B-6127-H106	25 watts	8.8 (heat sink in cabinet)	α50/3000HVis w/Fan	39.6	373.0
			0.44 (heat sink external to cabinet)	α50/3000HVis w/Fan	39.6	42.4

Section 31: Noise Protection

31.1 Grounding

A typical machine has three separate grounds:

- **Signal Ground:** Provides the reference potential (0 V) for the electrical signal system.
- **Frame Ground:** Ensures safety and shields external and internal noise.
- **System Ground:** Connects each unit and the inter-unit frame ground system to earth ground.

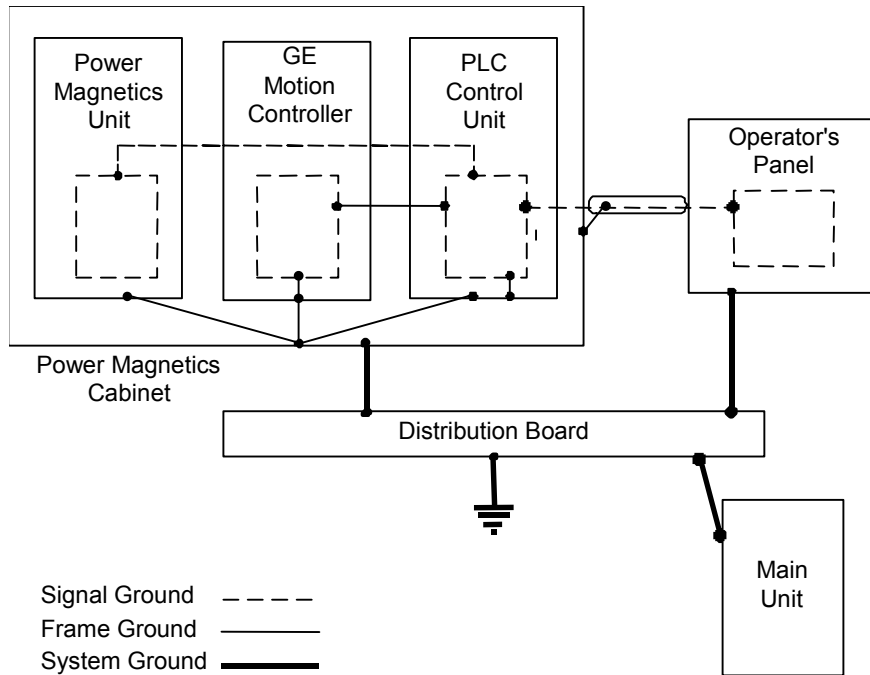

Figure IV-23. Ground System

Ground system wiring:

- Connect the signal ground (0V) with the frame ground (FG) at only one place in the power supply module.
- The grounding resistance of the system ground shall be 100 ohms or less (class D grounding).
- The system ground cable must have enough cross-sectional area to safely carry the accidental current flow into the system ground when an accident such as a short circuit occurs. (Generally, it must have the cross-sectional area of the AC power cable or more.)
- Use the cable containing the AC power wire and the system ground wire so that power is supplied with the ground wire connected.

Servo Products Specification Guide

Grounding of Each Module

- Separate the frame ground (FG) of the power system and that of the signal system. Otherwise, noise may propagate from the power system to the signal system, possibly causing the unit to malfunction.
- Connect the ground terminal of the Power Supply's CX1A connector to the frame ground. This acts as the signal ground. Connect the ground terminal of the metal frame to the frame ground.
- Connect the ground cable of the motor power cable to a ground terminal of the Servo Amplifier's terminal block. Connect the other ground terminal of the terminal block to the frame ground. Connect the ground terminal of the metal frame to the frame ground.
- On the Regenerative Discharge Unit and Dynamic Brake Module, connect the ground terminal of the metal frame to the frame ground.

Note:

- Securing the ground terminal and a cable together is not permitted.
- The motor flange mounting section may not be able to be connected to the machine mounting section of the power magnetics cabinet via the mechanical unit at sufficiently low impedance in a machine. In this case, a cable of a minimum required length that is at least 1.25 mm² thick must be run from the motor flange to the frame ground of the power magnetics cabinet. The cable must also be separated from the motor power line as much as possible.

31.2 Separation of Signal and Power Lines

When routing signal and power lines, the signal lines must be separated from the power lines to ensure best noise immunity. The table below lists the types of cables used:

Table IV-21. Servo amplifier signal line separation

Group	Signal Type	Action
A	Amplifier input power line Motor power line Magnetic contactor drive coil ¹	Separate these cables from those of group B by bundling them separately ² or by means of electromagnetic shielding ³ . Attach a noise suppressor (spark arrester) to the MCC drive coil.
B	Cable connecting control unit with servo amplifier Serial encoder feedback cable	Separate these cables from those of group A by bundling them separately* or by means of electromagnetic shielding**. In addition, shielding must be provided.

¹ Attach a noise suppressor such as a spark killer to the magnetic contactor drive coil.

² The bundle of group A cables must be separated from the bundle of group B cables by at least 10 cm.

³ Electromagnetic shielding involves shielding groups from each other by means of a grounded metal (steel) plate.

31.3 Cable Clamp and Shield Grounding

Terminal processing of the shield sheaths

Perform terminal processing of the shield sheaths of the signal cables according to the description in “ α HVi Series Servo System Connection” on page IV-48.

Cable clamp

The cables that run into the amplifier and which require shield processing must be clamped as indicated in Fig. 5.3.2(a).

Clamping secures a cable and also provides shielding. Clamping must always be performed since it is very important for stable system operation.

Strip part of the cable jacket to expose the shield sheath, as shown in the figure below. Secure that part of the cable to the ground plate by using a clamp. At this time, the ground plate must be in contact with the surface of the shield so that the contact area becomes wide.

Connect each shield cable to the ground plate installed near the cabinet inlet by using a ground clamp. This prevents noise generated in the panel from being emitted to external devices.

Connect the cable clamp of the signal cables of SVM connected to common PSM to common the ground plate for signals.

Grounding

The ground plate must be created and installed by the user as shown in Figure IV-24.

31.4 Encoder Feedback Cable Grounding

The motor encoder feedback cable shielding should be grounded by the method shown below. This cable clamp treatment provides both cable support (strain relief) and proper grounding of the shield. To ensure stable system operation, the cable clamp method is recommended. Partially peel back the cable sheath to expose the shield. Push the clamp (ZA99L-0035-0001) over the exposed shield and insert the clamp hooks into slots on the grounding bar (Z44B295864-001). Tighten the clamp to secure cable and complete the ground connection. The grounding bar must be attached to a low impedance earth ground.

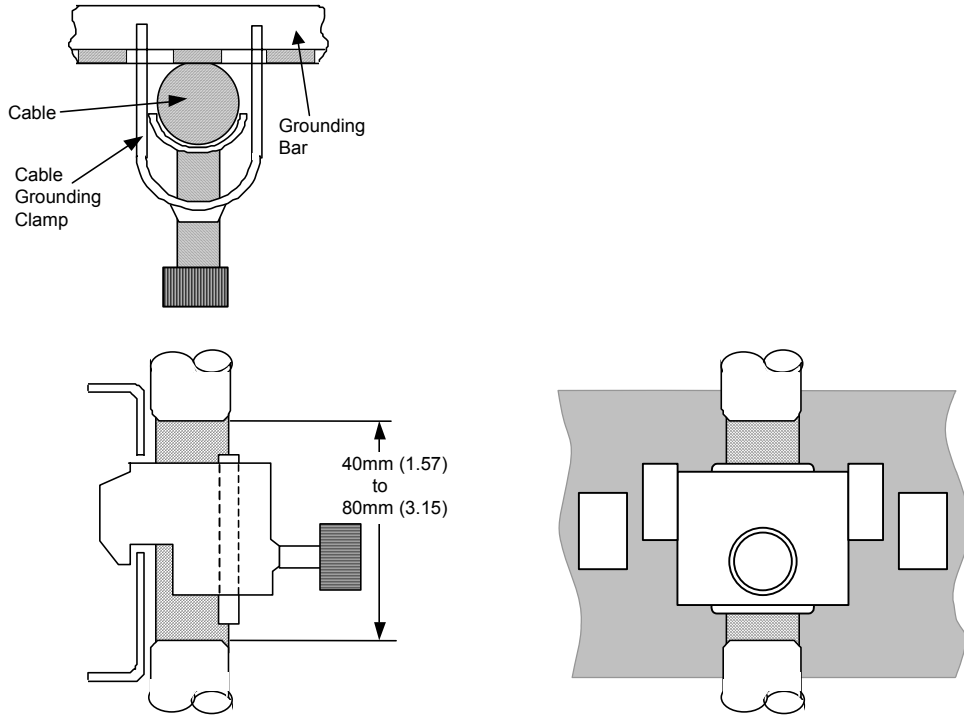

Figure IV-24. Cable Grounding Clamp Detail

Note: The grounding bar should be located as close as possible to the amplifier to minimize cable length between amplifier and grounding bar. Observe recommended maintenance clearance.

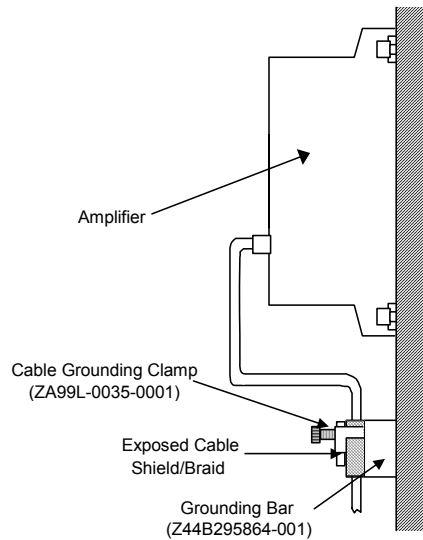

Figure IV-25. Feedback Cable Shield Grounding System

Servo Products Specification Guide

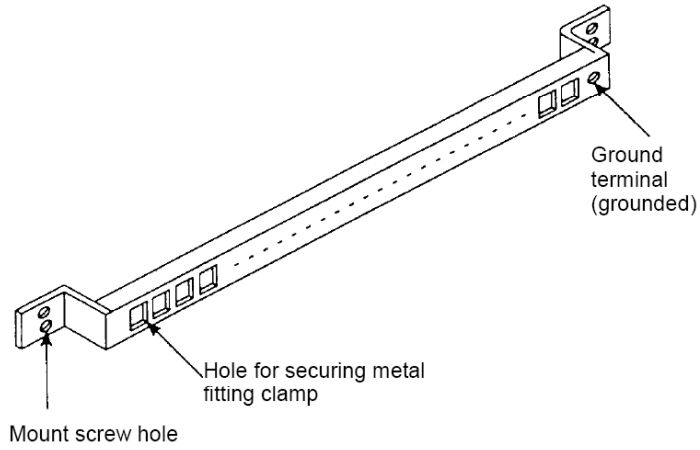

Figure IV-26. Ground Plate

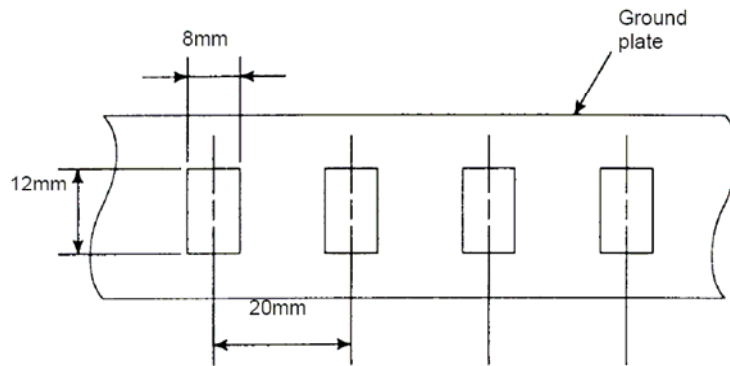

Figure IV-27. Ground Plate Holes

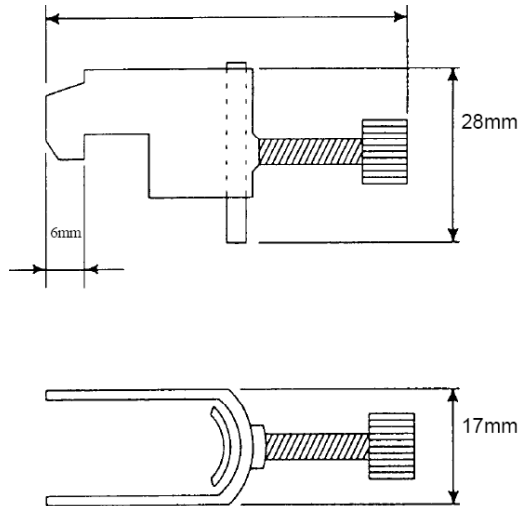

Figure IV-28. Metal Fittings for Clamp

Section 32: α HVi Servo System Power Requirements

This section provides information about AC and DC amplifier power as well as the discharge of regenerative power.

32.1 Power Line Protection

A circuit breaker, electromagnetic contactor, and AC line filter or transformer should be installed as part of your α HVi Series Servo system. The AC line filter is available as an option. The transformer, circuit breaker, and electromagnetic contactor, however, are user-supplied components. In European countries where power sources are 380 to 400 VAC and neutral grounded, it is necessary to install a transformer or supply single-phase power for the α i Series amplifiers.

The same incoming AC control components can be used to provide power to multiple amplifiers, as long as the components are rated for the current and power drawn by the sum of all of the amplifiers.

32.2 AC Line Filter

An AC line filter is recommended to suppress the influences of high-frequency input line noise on the drive power supply. When an isolation-type power transformer is used because a power supply voltage within the specified range is not available, an AC line filter is not required.

If two or more servo amplifiers are connected to one AC line filter, the total continuous output rating of all connected servo amplifiers should be kept below the continuous output rating of the AC line filter. The continuous output rating for the various servos are shown below.

Table IV-22. α i Servo Motor Continuous Output Rating at Low Line of 200 VAC

<i>Motor</i>	<i>Continuous Output Rating</i>
α 22/3000i	4.0 KW

Table IV-23. α HVis Servo Motor Continuous Output Rating at Low Line of 400 VAC

<i>Motor</i>	<i>Continuous Output Rating</i>
α 2/6000HVis	1.0 KW
α 4/5000HVis	1.0 KW
α 8/6000HVis	2.2 KW
α 12/4000HVis	2.5 KW
α 22/3000HVi	4.0 KW
α 22/4000HVis	4.5 KW
α 30/4000HVis	5.5 KW
α 40/4000HVis	5.5 KW
α 50/3000HVis with fan	14 KW

If your installation must be EMC compliant, verify that the use of an AC line filter fully satisfies the EMC requirements. You may need to select and install a user-supplied noise filter to meet EMC requirements.

AC Line Filter Outline Drawings and Specifications

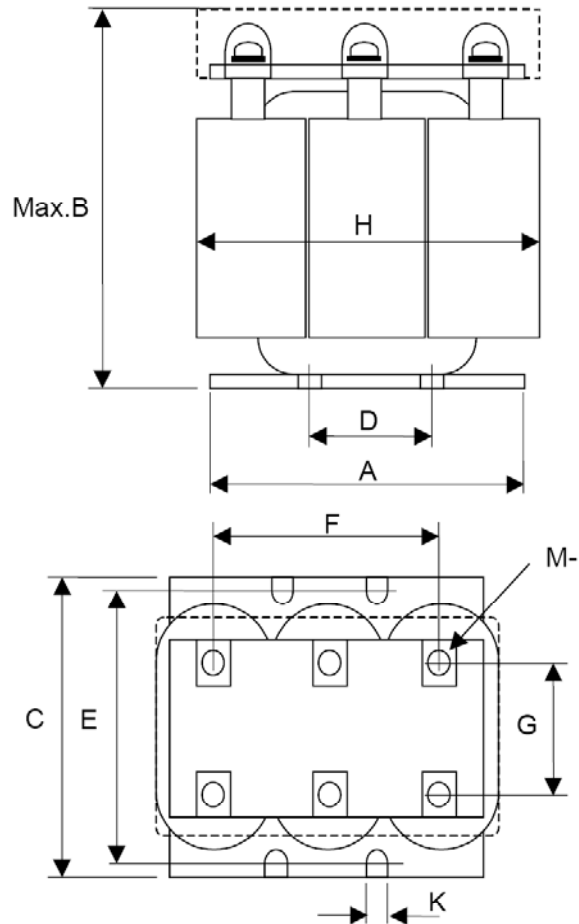

Dim.	AC Line Filter	
	ZA81L-0001-0163 for PSM-11HVi and PSM-18HVi	ZA81L-0001-0164 for PSM-30HVi and PSM-45HVi
A	135	185
B	155	172
C	165	175
D	55	70
E	145	154
F	84	116
G	66	106
H	135	185
K	7	7
M-	M5	M8

Figure IV-29. AC Line Filter Outline Drawing

32.3 Circuit Breaker and Magnetic Contactor Selection

The required circuit breaker and magnetic contactor capacities are determined by the power supply module specifications. The power supply model numbers and specifications of the circuit breakers and magnetic contactors are shown below.

Table IV-24. Circuit Breaker and Magnetic Contactor Specification

<i>Power Supply</i>	<i>Circuit Breaker 1</i>	<i>Circuit Breaker 2</i>	<i>Magnetic Contactor</i>
PSM-11HVi	20A	3A	20A
PSM-18HVi	45A		45A
PSM-30HVi	75A		75A
PSM-45HVi	125A		125A

Notes:

- For the installation positions of the circuit breakers and magnetic contactor, see the sample configuration on page IV-45.
- Set the rated voltage of circuit breakers 1 and 2 according to the power supply voltage.
- The current and voltage of the operation coil of the magnetic contactor must be within the rating of the internal contact CX3 (MCC) of the Power Supply. For details, see “Details of Cable K1” on page IV-65.

Sample Configuration for 400V Input Power

Notes:

- Single-phase 200VAC is required for the control power supply.
- A magnetic contactor, AC line filter, and circuit breakers are always required.
- To protect the unit from surge currents caused by lightning, connect surge absorbers between lines, and between the lines and ground, at the power inlet of the power magnetic cabinet.

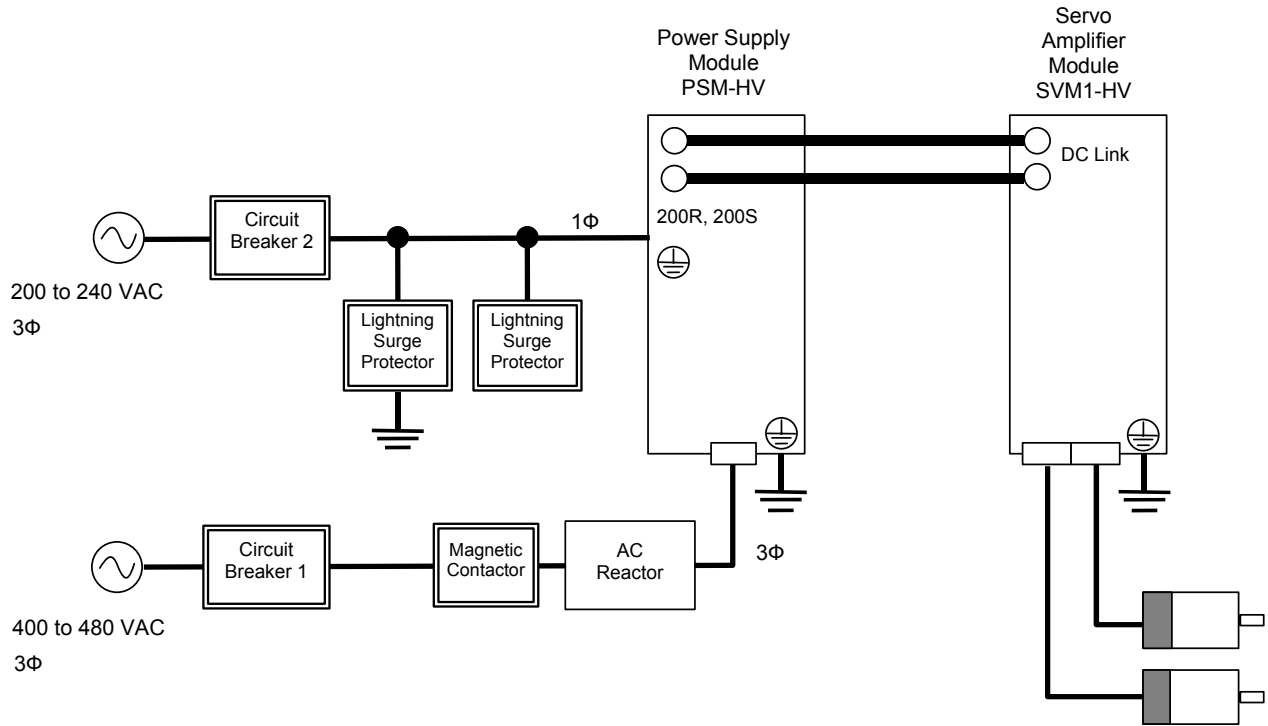

32.4 Incoming AC power

Table IV-25. AC Power

<i>Specification</i>	<i>αHVi Amplifiers</i>
Voltage for the main circuit: 3-phase (+10%, -15%) 1-phase (+10%, -15%)	400—480 VAC n/a
Power supply voltage for the control circuit	Single-phase 200 VAC to 240 VAC (input from connector CX1A)
Allowable voltage deviation	-15% to =10% (including voltage variation due to load)
Frequency	50 Hz/60Hz, ±1 Hz
Power supply unbalance	±5% of the rated voltage or less
Power supply impedance Note: When the power supply impedance is high, and the voltage variation exceeds the specified values, a PSM alarm (DC link undervoltage alarm or DC link overvoltage alarm) can be issued, or the output of the motor can decrease.	The voltage variation must be within ±7% when a maximum output is produced for voltage at non-load time (power running and regeneration).

AC Power Ratings

The power supply rating required when using multiple servo motors can be determined by summing the requirements of the individual motors.

The power supply ratings listed in Table IV-26 are sufficient as continuous ratings. Note, however, that servo motor acceleration causes a current to momentarily flow that is approximately three times the continuous current rating.

When the power is turned on, a surge current of about 37A (when 264VAC is applied) flows for 20 msec.

Table IV-26. Three-Phase Power Supply Ratings

<i>Motor</i>	<i>Continuous Output Rating</i>
α2/6000HVis	1.0 KW
α4/5000HVis	1.0 KW
α8/6000HVis	2.2 KW
α22/4000HVis	4.5 KW
α30/4000HVis	5.5 KW
α40/4000HVis	5.5 KW
α50/3000HVis with fan	14 KW

Servo Products Specification Guide

Power Supply of 400V Input Series

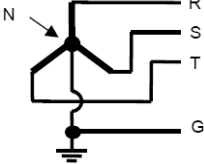
Item	Specification
Power supply voltage for the main circuit	Three-phase 400 VAC to 480 VAC Star connection, neutral grounding (For details, see items (5) and (6).) 
Power supply voltage for the control circuit	Single-phase 200 VAC to 240 VAC (input from connector CX1A) (For details, see Item 7.)
Allowable voltage deviation	-15% to +10% (including voltage variation due to load)
Power frequency	50/60Hz, ± 1 Hz
Power supply unbalance	$\pm 5\%$ of the rated voltage or less
Power supply impedance (Note)	The voltage variation must be within $\pm 7\%$ when a maximum output is produced for voltage at non-load time (power running and regeneration).

Section 33: α HVi Series Servo System Connection

When planning your motion control system, it is important to determine how the different parts of the system connect together. This section provides information on the various cables and connectors required to connect the motor, amplifier and motion controller.

Many cables required for the system are available from GE Intelligent Platforms. Motor cable and connector kit part numbers for each motor and amplifier combination are shown in the tables below.

Table IV-27. α 2HVis to α 8HVis Motor Power, Feedback and Brake Cables, and Connector Kits

<i>Motor Model</i>		<i>α2/6000HVis</i>	<i>α4/5000HVi</i>	<i>α8/6000HVis</i>
<i>Amplifier Model</i>		<i>αSVM1-10HVi βSVM1-10HVi</i>	<i>αSVM1-10HVi βSVM1-10HVi</i>	<i>αSVM1-40HVi βSVM1-40HVi</i>
Motor Feedback Cable (90° Connector)	7m	CFDA-3WPB-0070-AZ	CFDA-3WPB-0070-AZ	CFDA-3WPB-0070-AZ
	14m	CFDA-3WPB-0140-AZ	CFDA-3WPB-0140-AZ	CFDA-3WPB-0140-AZ
Motor Feedback Cable (Straight Connector)	7m	CFDA-0WPB-0070-AZ	CFDA-0WPB-0070-AZ	CFDA-0WPB-0070-AZ
	14m	CFDA-0WPB-0140-AZ	CFDA-0WPB-0140-AZ	CFDA-0WPB-0140-AZ
Motor Power Cable	7m	CP2I-0WPB-0070-AZ	CP2I-0WPB-0070-AZ	CP3I-0WPB-0070-AZ
	14m	CP2I-0WPB-0140-AZ	CP2I-0WPB-0140-AZ	CP3I-0WPB-0140-AZ
Motor Brake Power Cable	7m	Integrated with power cable	Integrated with power cable	Integrated with power cable
	14m			
Motor Power Cable, Shielded	7m	CP2I-0WEB-0070-AZ	CP2I-0WEB-0070-AZ	CP3I-0WEB-0070-AZ
	14m	CP2I-0WEB-0140-AZ	CP2I-0WEB-0140-AZ	CP3I-0WEB-0140-AZ
PSM Interface Cable (panel mounted battery)	0.2m	Z44C746453-001	Z44C746453-001	Z44C746453-001
PSM Interface Cable (Built-in Lithium Battery or No battery)	0.2m	Z44C746453-002	Z44C746453-002	Z44C746453-002
PSM Power Supply Module Connector Kit	NA	NA	NA	ZA06B-6071-K203
Amplifier CXA2A/B Connector	NA	ZA06B-6110-K210	ZA06B-6110-K210	ZA06B-6110-K210

Servo Products Specification Guide

Table IV-28. α 12HVis to α 22HVis Motor Power, Feedback and Brake Cables, and Connector Kits

<i>Motor Model</i>		<i>α12/4000HVis</i>	<i>α22/3000HVi</i>	<i>α22/4000HVis</i>
<i>Amplifier Model</i>		<i>αSVM1-40HVi</i>	<i>αSVM1-40HVi</i>	<i>αSVM1-80HVi</i>
Motor Feedback Cable (90° Connector)	7m	CFDA-3WPB-0070-AZ	CFDA-3WPB-0070-AZ	CFDA-3WPB-0070-AZ
	14m	CFDA-3WPB-0140-AZ	CFDA-3WPB-0140-AZ	CFDA-3WPB-0140-AZ
Motor Feedback Cable (Straight Connector)	7m	CFDA-0WPB-0070-AZ	CFDA-0WPB-0070-AZ	CFDA-0WPB-0070-AZ
	14m	CFDA-0WPB-0140-AZ	CFDA-0WPB-0140-AZ	CFDA-0WPB-0140-AZ
Motor Power Cable	7m	CP3I-0WPB-0070-AZ	CP4I-0WPB-0070-AZ	CP4I-0WPB-0070-AZ
	14m	CP3I-0WPB-0140-AZ	CP4I-0WPB-0140-AZ	CP4I-0WPB-0140-AZ
Motor Brake Power Cable	7m	CB4N-0WPM-0070-AZ	CB4N-0WPM-0070-AZ	CB4N-0WPM-0070-AZ
	14m	CB4N-0WPM-0140-AZ	CB4N-0WPM-0140-AZ	CB4N-0WPM-0140-AZ
Motor Power Cable, Shielded	7m	CP4I-0WEB-0070-AZ	CP4I-0WEB-0070-AZ	CP4I-0WEB-0070-AZ
	14m	CP4I-0WEB-0140-AZ	CP4I-0WEB-0140-AZ	CP4I-0WEB-0140-AZ
PSM Interface Cable (panel mounted battery)	0.2m	Z44C746453-001	Z44C746453-001	Z44C746453-001
PSM Interface Cable (Built-in Lithium Battery or No battery)	0.2m	Z44C746453-002	Z44C746453-002	Z44C746453-002
PSM Power Supply Module Connector Kit	NA	ZA06B-6071-K203	ZA06B-6071-K203	ZA06B-6071-K203
Amplifier CXA2A/B Connector	NA	ZA06B-6110-K210	ZA06B-6110-K210	ZA06B-6110-K210

Servo Products Specification Guide

Table IV-29. α 30HVis to α 50HVis Motor Power, Feedback and Brake Cables, and Connector Kits

<i>Motor Model</i>		<i>α30/4000HVis</i>	<i>α40/4000HVis</i>	<i>α50/3000HVis with fan</i>
<i>Amplifier Model</i>		<i>αSVM1-80HVi</i>	<i>αSVM1-180HVi</i>	<i>αSVM1-180HVi</i>
Motor Feedback Cable (90° Connector)	7m	CFDA-3WPB-0070-AZ	CFDA-3WPB-0070-AZ	CFDA-3WPB-0070-AZ
	14m	CFDA-3WPB-0140-AZ	CFDA-3WPB-0140-AZ	CFDA-3WPB-0140-AZ
Motor Feedback Cable (Straight Connector)	7m	CFDA-0WPB-0070-AZ	CFDA-0WPB-0070-AZ	CFDA-0WPB-0070-AZ
	14m	CFDA-0WPB-0140-AZ	CFDA-0WPB-0140-AZ	CFDA-0WPB-0140-AZ
Motor Power Cable	7m	CP4I-0WPB-0070-A	CP4I-0WPB-0070-A	CP9I-0MPB-0070-AZ
	14m	CP4I-0WPB-0140-A	CP4I-0WPB-0140-A	CP9I-0MPB-0140-AZ
Motor Power Cable, Shielded	7m	CP4I-0WEB-0070-AZ	CP4I-0WEB-0070-AZ	CP9I-0MEB-0070-AZ
	14m	CP4I-0WEB-0140-AZ	CP4I-0WEB-0140-AZ	CP9I-0MEB-0140-AZ
Motor Brake Power Cable	7m	CB4N-0WPM-0070-AZ	CB4N-0WPM-0070-AZ	CB4N-0WPM-0070-AZ
	14m	CB4N-0WPM-0140-AZ	CB4N-0WPM-0140-AZ	CB4N-0WPM-0140-AZ
Motor Fan Power Cable	7m	NA	NA	CB5N-0WPM-0070-AZ
	14m	NA	NA	CB5N-0WPM-0140-AZ
PSM Interface Cable (panel mounted battery)	2m	Z44C746453-001	Z44C746453-001	Z44C746453-001
PSM Interface Cable (Built-in Lithium Battery or No battery)	2m	Z44C746453-002	Z44C746453-002	Z44C746453-002
PSM Power Supply Module Connector Kit	NA	ZA06B-6071-K203	ZA06B-6071-K203	ZA06B-6071-K203
Amplifier CXA2A/B Connector	NA	ZA06B-6110-K210	ZA06B-6110-K210	ZA06B-6110-K210
CX8/CX9 Dynamic Brake Module Interface Connector Kit	NA	NA	NA	ZA06B-6073-K216
CX1A/B Dynamic Brake Module Control Power Connector Kit	NA	NA	NA	ZA02B-0120-K321

33.1 Motor Power Connectors

For the Servo Motor αi , αHVi and $\alpha HVis$ series, connect the power line of the motor and the signal line of an absolute encoder to an $\alpha SVM1$ Servo Amplifier. When the motor has a built-in brake or cooling fan as an option, connect the built-in brake or cooling fan to the specified power supply.

Table IV-30. Connectors for αi , αHVi and $\alpha HVis$ Motors

<i>Motor Type</i>	<i>for Power</i>
$\alpha 12/4000HVis$	90°: Z44A730464-G18
	Straight: Z44A730464-G17
$\alpha 22/3000i$	90°: Z44A730464-G20
	Straight: Z44A730464-G19
$\alpha 22/3000HVi$	90°: Z44A730464-G20
	Straight: Z44A730464-G19
$\alpha 22/4000HVis$	90°: Z44A730464-G20
	Straight: Z44A730464-G19
$\alpha 30/4000HVis$	90°: Z44A730464-G20
	Straight: Z44A730464-G19
$\alpha 40/4000HVis$	90°: Z44A730464-G20
	Straight: Z44A730464-G19
$\alpha 50/3000HVis$ with fan	90°: Z44A730464-G20
	Straight: Z44A730464-G19

CAUTION

Motors should be installed with their connector facing downward if possible. When it is impossible to install a motor in this position, allow slack in the cable to keep liquids such as a dielectric fluid from flowing along the cable into the cable capacitor or motor. If there is a possibility that the motors and connectors will get wet, provide a cover to protect them.

If a motor is not connected to the earth ground through the machine (frame), connect the motor grounding point and the amplifier grounding point to absorb noise using a 1.25 mm² or larger conductor other than the grounding conductor in the power cable. Keep the grounding conductor as far from the power cable as possible.

33.2 Encoder Connectors for *ai*, *αHVi* and *αHVis* Motors

For all servo motors of the *ai* series, a small dedicated connector is used for the Encoder signals. The connector is drip-proof when engaged with the motor connector.

There are two types of connectors depending on how a cable is connected to a connector: the crimp type and the solder type. For the crimp type connector, a dedicated crimping tool is required.

The diameter of the cable used is restricted considering cable clamp and voltage drop. The connectors for signals do not have to conform to IEC60034.

Crimp Type Connector

Connector Specifications		For Signal	
Straight Type		JN2DS10SL1-R or JN2DS10SL2-R: Connector JN1-22-22S: Contact (Japan Aviation Electronics Industry) Connector ZA06B-6114-K204#S (FANUC specification)* Including the contact	
Right Angle Type		JN2FS10SL1-R or JN2FS10SL2-R: Connector JN1-22-22S: Contact (Japan Aviation Electronics Industry) ZA06B-6114-K204#E (FANUC specification)* Including the contact	
Insulation external diameter		Φ1.5 or less	
Compatible cable O.D.		Φ5.7 to Φ7.3: JN2DS10SL1-R or JN2FS10SL1-R Φ6.5 to Φ8.0: JN2DS10SL2-R or JN2FS10SL2-R *With the FANUC specifications, two types of bushings: for Φ5.7 to Φ7.3 and for Φ6.5 to Φ8.0 are included.	
Wire		Cable length: 28m or less	Cable length: 50m or less
	5V, 0V	0.3 mm ² x 2	0.5mm ² x 2 *Use a cable with strand configuration 20/0.18 or 104/0.08.
	6V	0.3 mm ² x 2	0.5mm ² *Use a cable with strand configuration 20/0.18 or 104/0.08.
	RD, *RD	Twisted pair of at least 0.18 mm ²	
Tool for crimping terminal	AWG#21 (0.5mm ² :20/0.18)		CT150-2-JN1-E (Japan Aviation Electronics Industry) A06B-6114-K201#JN1E (FANUC specification)
	AWG#23 (0.3mm ²)		
	AWG#25 (0.18mm ²)		
	AWG#20 (0.5mm ² :104/0.08)		CT150-2-JN1-D (Japan Aviation Electronics Industry) A06B-6114-K201#JN1D (FANUC specification)
	AWG#21 (0.5mm ² :20/0.18)		
	AWG#25 (0.18mm ²)		
Tool for pulling terminal out		ET-JN1(Japan Aviation Electronics Industry) A06B-6114-K201#JN1R (FANUC specification)	

Servo Products Specification Guide

The outside dimensions of each type of connector when engaged are shown below:

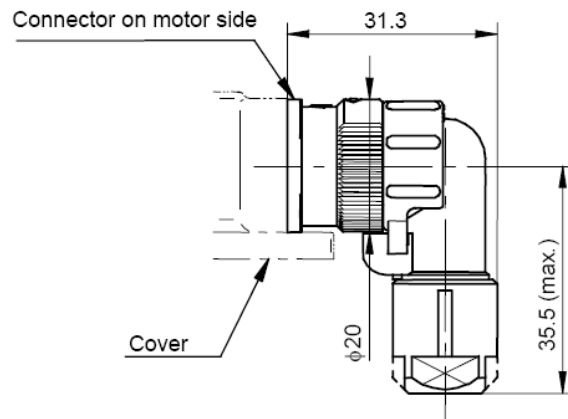
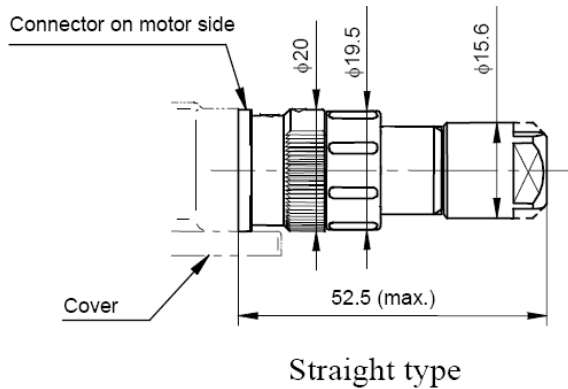

Solder Type Connector

Connector specifications		For Signal	
Straight type		HR34B-12WPA-10S or HR34B-12WPB-10S (Hirose Electric) ZA06B-6114-K205#S (FANUC specification)	
Right angle type		HR34B-12WLPA-10S or HR34B-12WLPB-10S (Hirose Electric) ZA06B-6114-K205#E (FANUC specification)	
Applicable wire size		AWG#20 or less (φ0.8mm or less)	
Compatible cable O.D.		φ5.7 to φ7.3: HR34B-12WPA-10S or HR34B-12WLPA-10S φ6.5 to φ8.0: HR34B-12WPB-10S or HR34B-12WLPB-10S *FANUC specification includes two types of bushings and end nuts for φ5.7 to φ7.3 and for φ6.5 to φ8.0.	
Wire		Cable length: 28 m or less	Cable length: 50 m or less
	5V, 0V	0.3 mm ² × 2	0.5 mm ² × 2
	6V	0.3 mm ²	0.5mm ²
	RD, *RD	Twisted pair of at least 0.18 mm ²	

The outside dimensions of each type of connector when engaged are shown below:

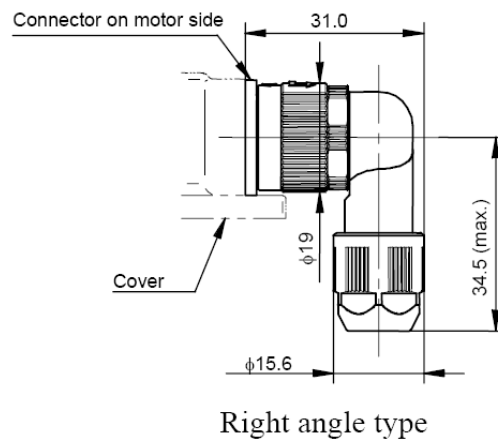
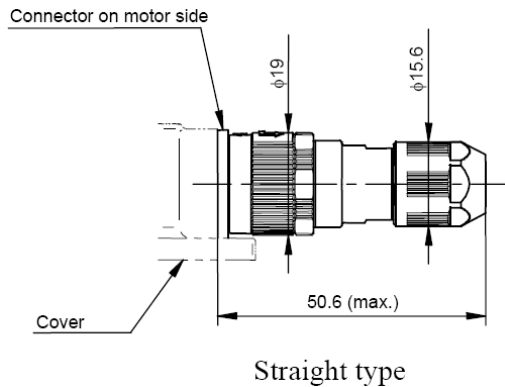

33.3 Connectors for Power

To meet the IEC60034 standard, TUV-approved plug connectors and cable clamps should be used to connect the power cable. To meet the IEC60034 standard by using a cable or conduit hose seal adapter, contact the manufacturer for details. GE Intelligent Platforms can provide TUV-approved types (waterproof) and waterproof types as plug connectors on the cable side for the *αi* series AC servo motors. All these connectors are black. Of course, conventional plug connectors may be used, because they are MS-compatible. The specifications of each connector are explained based on the examples shown below. The specification numbers used for ordering a power connector kit are listed below. The power connector kit contains a plug connector on the cable side (waterproof conforming to IP67, TUV approved type) described subsequently.

Motors	Power connector kit specification	Content
α12/4000HVis	Z44A730464-G17	Straight type connector + cable clamp
	Z44A730464-G18	Right angle type connector + cable clamp
α22/3000i, α22/3000HVi α22/4000HVis, α30/4000HVis α40/4000HVis, and α50/3000HVis with fan	Z44A730464-G19	Straight type connector + cable clamp
	Z44A730464-G20	Right angle type connector + cable clamp

Connection Example

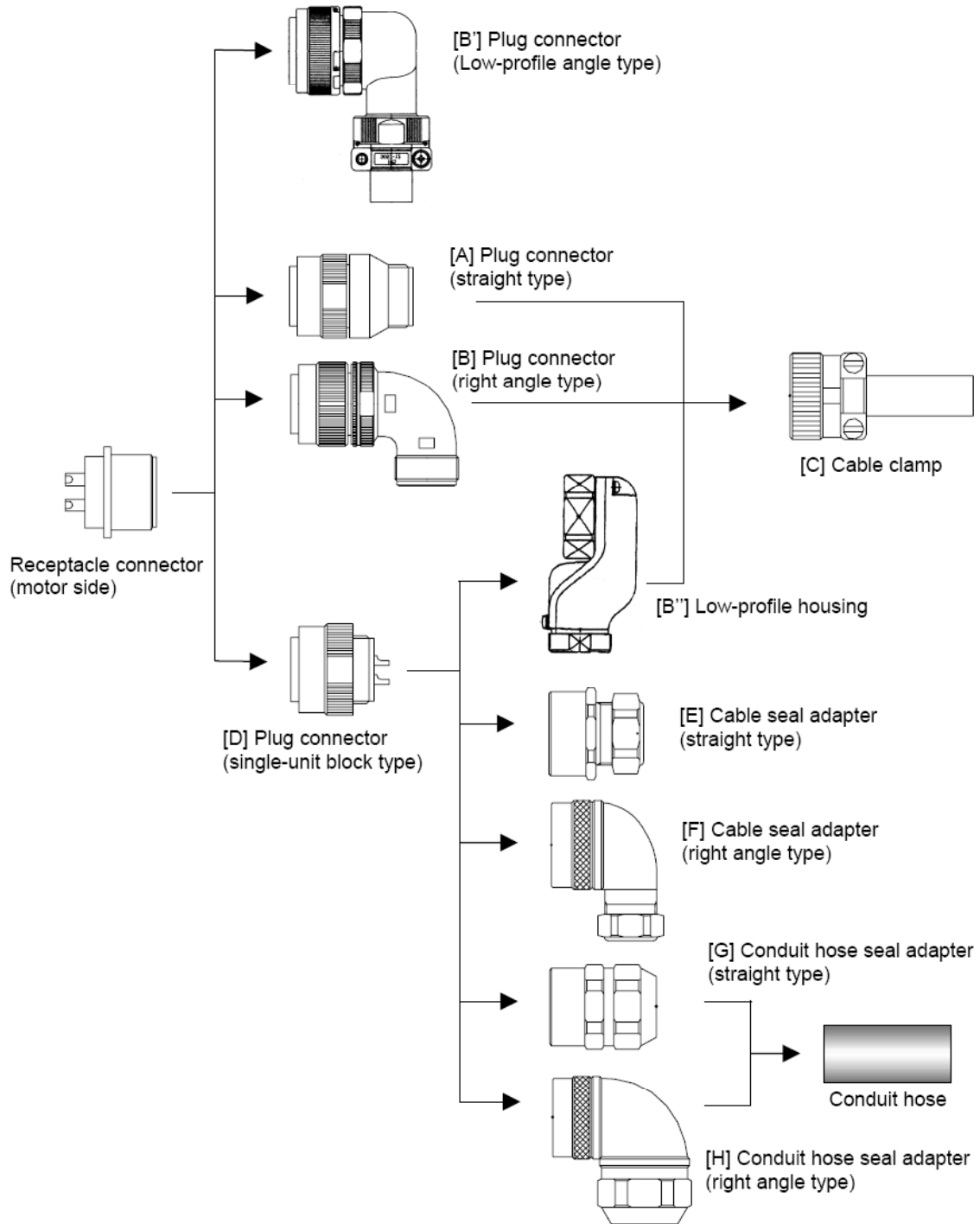

Servo Products Specification Guide

Motor Power Connectors (support for waterproof IP67, TUV-approved type)

Listed below are the manufacturer's part numbers for waterproof (conforming to IP67), TUV-approved motor power connectors supplied by the manufacturers listed. For details of the connectors, contact each manufacturer.

Motor	[D] Single Block Type Plug Connector	[A] Straight Type Plug Connector	[B] Right angle Type Plug Connector	[B'] Low profile angle type plug connector (with clamp)	[B''] Low profile housing	[C] Cable Clamp
α12/4000HVis	Hirose Electric					
	H/MS3106A 18-10S-D-T(13)	H/MS3106A 18-10S-D-T(10)	H/MS3108A 18-10S-D-T(10)	(1) H/MS3108A 18-10S- DT10D(10) (2) H/MS3108A 18-10S- DT10D1(10)	-	H/MS3057-10A (10)
	Solder pot diameter φ2.6			Solder pot diameter φ2.5 Compatible cable O.D. (1) φ2 - φ14.3 (2) φ10 - φ12.5	-	Compatible cable O.D. φ10.3 - φ14.3 0
α22/3000i, α22/3000HVi α22/4000HVis, α30/4000HVis, α40/4000HVis, and α50/3000HVis with fan	Japan Aviation Electronics Industry					
	JL04V-6A22- 22SE-R Both (1) and (2)	(1) JL04V- 6A22-22SE-EB- R (2) JL04V- 6A22-22SE- EB1-R	(1) JL04V- 8A22-22SE-EB- R (2) JL04V- 8A22-22SE- EB1-R	-	(1) JL04-22EBA (2) -	(1) JL04- 2022CK (14)-R (2) JL04- 2428CK (20)-R
	Solder pot diameter φ5.3 Applicable wire (1) 5.5mm ² or less, (2) 10mm ² or less			-	Compatible cable O.D. (1) φ12.9 - φ16, (2) φ18 - φ20	

Servo Products Specification Guide

Plug Connectors on the Cable Side (support for waterproof IP67)

Listed below are the manufacturer's part numbers for waterproof (conforming to IP67) plug connectors on the cable side, supplied by the manufacturers listed. For details of the connectors, contact each manufacturer.

Model Name	[D] Single Block Type Plug Connector	[A] Straight Type Plug Connector	[B] Right Angle Type Plug Connector	[B] Low-profile angle type plug connector	[B"] Low-profile housing	[C] Cable Clamp
α12/4000HVis	Japan Aviation Electronics Industry					
	JA06A-18-10S-J1-R	JA06A-18-10S-J1-EB-R	JA08A-18-10S-J1-EB-R		JL04V-18EBA	JL04-18CK (13)-R
	Hirose Electric					
	H/MS3106A 18-10S(13)	H/MS3106A 18-10S(10)	H/MS3108B 18-10S(10)	H/MS08A18-10S-DT10D(10)		H/MS3057-10A(10)
	DDK Ltd.					
D/MS3106A 18-10S-B(D190)	D/MS3106A 18-10S-B-BSS	D/MS3108A 18-10S-B-BAS			CE3057-10A-1-D	
α22/3000i, α22/3000HVi α22/4000HVis, α30/4000HVis α40/4000HVis, and α50/3000HVis with fan	Japan Aviation Electronics Industry					
	JA06A-22-22S-J1-R	JA06A-22-22S-J1-EB-R	JA08A-22-22S-J1-EB-R		JL04V-22EBA	JL04-2022CK (14)-R
	Hirose Electric					
	H/MS3106A 22-22S(13)	H/MS3106A 22-22S(10)	H/MS3108B 22-22S(10)	H/MS08A22-22S-DT12D(10)		H/MS3057-12A(10)
	DDK Ltd.					
D/MS3106A 22-22S-B(D190)	D/MS3106A 22-22S-B-BSS	D/MS3108A 22-22S-B-BAS			CE3057-12A-1-D	

33.4 Connectors for the Brake

The αHV*i*S Series servo motors use a dedicated connector to connect power for the built-in brake. This connector is drip-proof. Because it is connected by soldering, no special tool is required.

This connector differs from conventional connectors used for the α Series. The following subsection explains this connector.

Consider soldering, cable clamp, and voltage drop. Also note that there are restrictions. The connector for the 24-V brake does not conform to the IEC60034 standard.

Connector Specifications

Straight type	JN2DS04FK2-R (Japan Aviation Electronics Industry) ZA06B-6114-K213#S (FANUC specification)
Right angle	JN2FS04FK2-R (Japan Aviation Electronics Industry) ZA06B-6114-K213#E (FANUC specification)
Applicable wire size	AWG#16 or less (1.25mm ² or less) *Solder pot diameter φ1.9
Insulation external diameter	φ2.7 or less
Compatible cable O.D.	φ6.5 to φ8.0
Example of applicable wire	300-V two-conductor vinyl heavy-duty power cord cable VCTF (JIS C 3306) or equivalent
Applicable wire size and cable length	0.75mm ² (AWG#18) when cable length 30m or less 1.25mm ² (AWG#16) when cable length 50m or less

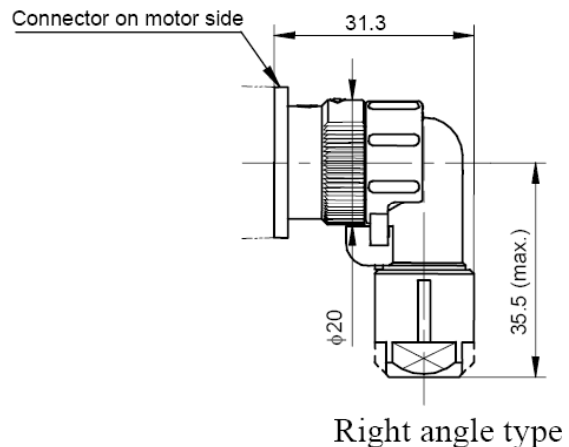
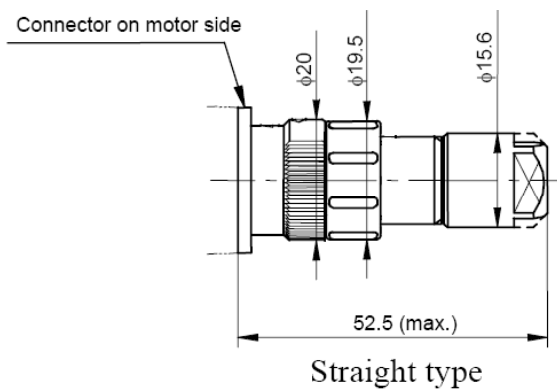

Notes:

- The same body is used for the brake and fan connectors. They differ in the key position to prevent an improper insertion.
- If the cable length is longer than or equal to 50 m, take measures such as installation of repeaters so that the sum of wire resistance (for both ways) becomes 1.5Ω or less.
- For details of brakes, “Built-in Brake” on page IV-16.

33.5 Connectors for the Fan

The *aiS* 50/3000HV with fan uses a dedicated connector to connect the power supply for the fan.

This connector is drip-proof. Because it is connected by soldering, no special tool is required.

This connector differs from conventional connectors used for the α Series. The following subsection explains this connector.

Consider soldering, cable clamp, and voltage drop. Also note that there are restrictions.

Connector Specifications for *aiS* 50/3000HV with Fan

Connector Type	Straight type	JN2DS04FK2X-R (Japan Aviation Electronics Industry) ZA06B-6114-K214#S (FANUC specification)
	Right angle	JN2FS04FK2X-R (Japan Aviation Electronics Industry) ZA06B-6114-K214#E (FANUC specification)
Applicable wire size	AWG#16 or less (1.25mm^2 or less) *Solder pot diameter $\phi 1.9$	
Insulation external diameter	$\phi 2.7$ or less	
Compatible cable O.D.	$\phi 6.5$ to 8.0	
Example of applicable wire	300-V two-conductor vinyl heavy-duty power cord cable VCTF (JIS C 3306) or equivalent	
Applicable wire size and cable length	0.5 mm^2 or more (AWG#20)	

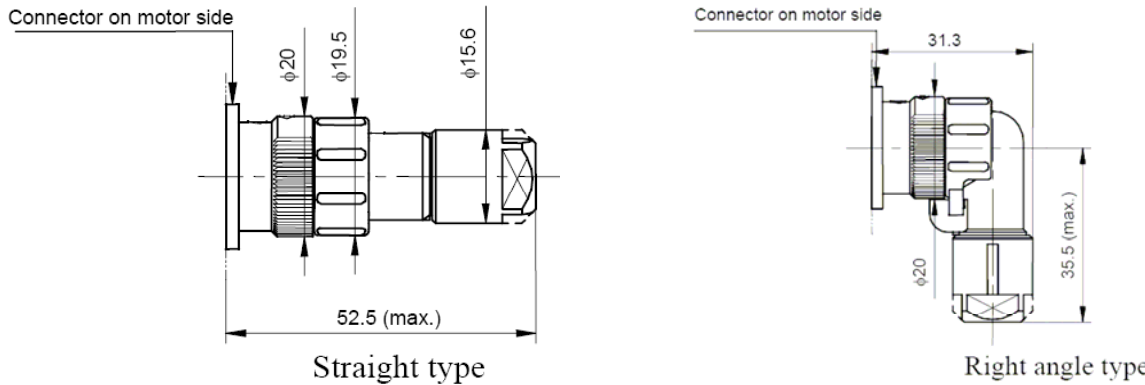

Notes:

- The same body is used for the brake and fan connectors. They differ in the key position to prevent an improper insertion.
- If the cable length is longer than or equal to 50 m, take measures such as installation of repeaters so that the sum of wire resistance (for both ways) becomes 1.5Ω or less.

33.6 Connection to a Conduit Hose

This section provides manufacturer's part numbers for of several adapters that are made by conduit hose manufacturers. Before using an adapter, contact the corresponding conduit hose manufacturer for more details.

Manufacturer's Part Numbers for Conduit Hose Adapters (Waterproof type/seal adapter specifications)

Model Name	[E] Cable Seal adapter Straight type	[F] Cable Seal adapter Elbow type	[G] Conduit hose Seal adapter Straight type	[H] Conduit hose Seal adapter Elbow type
For power				
α12/4000HVis	CKD12-18 (SANKEI) YSO 18-12-14 (DAIWA DENGYOU) ACS-12RL-MS18F (NIPPON FLEX) CG12S-JL18 (NEOFLEX)	C90° KD12-18 (SANKEI) YLO 18-12-14 (DAIWA DENGYOU) ACA-12RL-MS18F (NIPPON FLEX) CG12A-JL18 (NEOFLEX)	KKD16-18 (SANKEI) MSA 16-18 (DAIWA DENGYOU) RCC-104RL-MS18F (NIPPON FLEX) MAS16S-JL18 (NEOFLEX)	K90° KD16-18 (SANKEI) MAA 16-18 (DAIWA DENGYOU) RCC-304RL-MS18F (NIPPON FLEX) MAS16A-JL18 (NEOFLEX)
α22/3000i, α22/3000HV α22/4000HVis, α30/4000HVis α40/4000HVis, and α50/3000HVis with fan	CKD16-22 (SANKEI) YSO 22-12-14 (DAIWA DENGYOU) ACS-16RL-MS22F (NIPPON FLEX) CG16S-JL22 (NEOFLEX)	C90° KD16-22 (SANKEI) YLO 22-12-14 (DAIWA DENGYOU) ACA-16RL-MS22F (NIPPON FLEX) CG16A-JL22 (NEOFLEX)	KKD22-22 (SANKEI) MSA 22-22 (DAIWA DENGYOU) RCC-106RL-MS22F (NIPPON FLEX) MAS22S-JL22 (NEOFLEX)	K90° KD22-22 (SANKEI) MAA 22-22 (DAIWA DENGYOU) RCC-306RL-MS22F (NIPPON FLEX) MAS22A-JL22 (NEOFLEX)
For signal				
Common to all models			N2KY16-FN3 (SANKEI) PCJN-12-M13F (DAIWA DENGYOU) RQJN-M13-9 RQJN-M13-16 (NEOFLEX)	
For brake				
Common to all models			N2KY16-FN3 (SANKEI) PCJN-12-M13F (DAIWA DENGYOU) RQJN-M13-9 RQJN-M13-16 (NEOFLEX)	

(*) ManufactureSANKEI: SANKEI MANUFACTURING CO.,LTD. DAIWA DENGYOU: DAIWA DENGYOU CO.,LTD. NIPPON FLEX: NIPPON FLEX CO.,LTD. NEOFLEX

33.7 System Connection Diagram and Cable Reference

Motor and amplifier connector kits required for the system are available from GE Intelligent Platforms. The following figures indicate the physical connector locations on the amplifiers, the appropriate connector designations and connector kit part numbers.

The following diagrams illustrate typical system connections. For details on cables and connectors, refer to Table 101HIV-31 on page IV-64.

Amplifier Connections

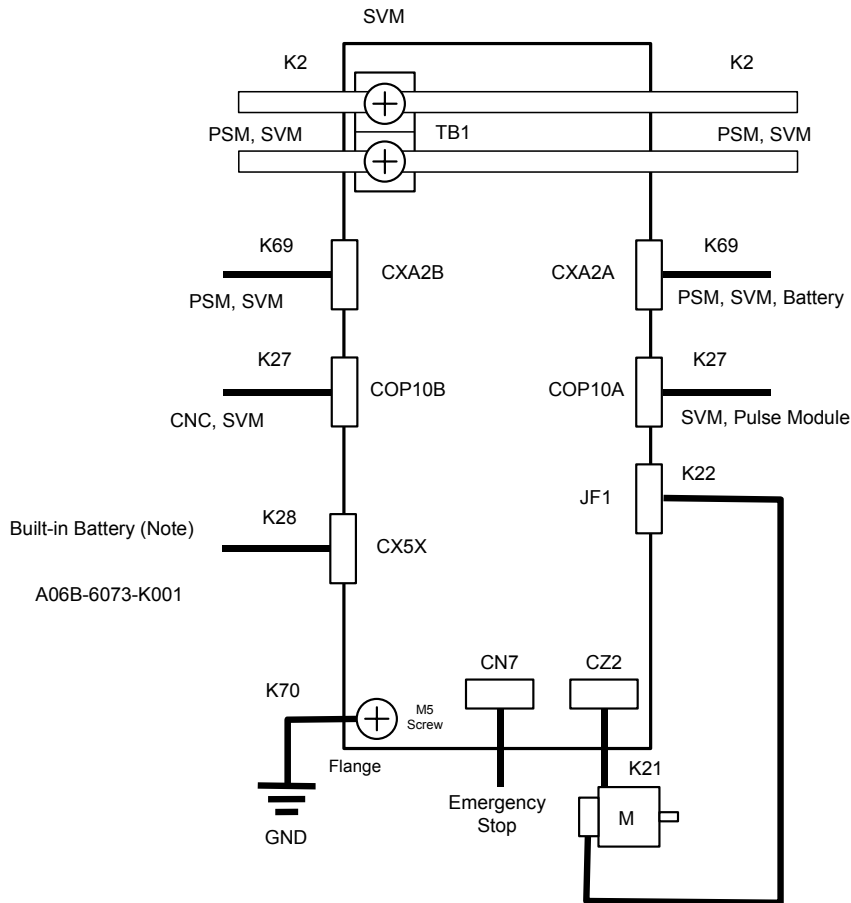

Note: See page IV-29 for details on connection to the battery.

Connector Location

Name	Cable	Description
TB1	K2	DC link
CXA2A/CXA2B	K69	Communication cable between modules
COP10A/COP10B	K27	FSSB interface
CX5X	K28	Built-in battery connector
CZ2L	K21	Output power to servo motor
JF1	K22	Serial encoder feedback
CZ2M	K21	Output power to servo motor
CN7		Emergency stop
	K70	Protective ground connection

Figure IV-30. αSVM1-40i and αSVM1-80i Connection Diagram

Servo Products Specification Guide

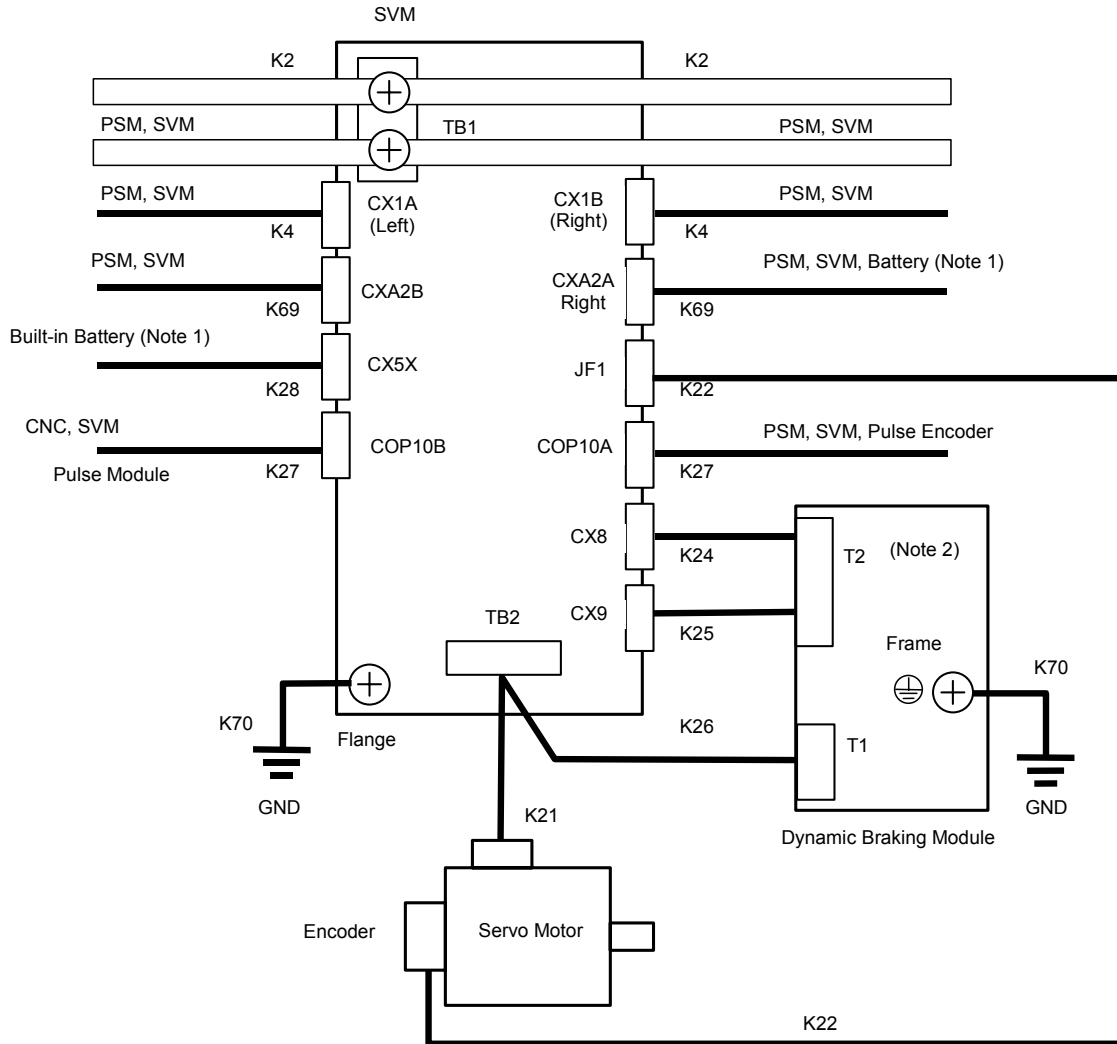

- Note:** 1. See page IV-26 for details on connection to the multi-axis battery pack or the built-in battery.
2. Connect one dynamic brake module for each servo amplifier.

Connector Location

Name	Cable	Description
TB1	K2	DC link
CX1A/CX1B	K4	Input power for dynamic brake module
CXA2A/CXA2B	K69	Communication cable between modules (SVM1-180HVi only)
CX5X	K28	Built-in battery connector
COP10A/COP10B	K27	FSSB interface
JF1	K22	Serial encoder feedback
CX8	K24	Dynamic brake module
CX9	K25	Dynamic brake module.
TB2	K26	Power to dynamic brake module
	K21	Power to servo motor
⊕	K70	Protective ground connection

Figure IV-31. αSVM1-180HVi Connection Diagram

Power Supply Connections

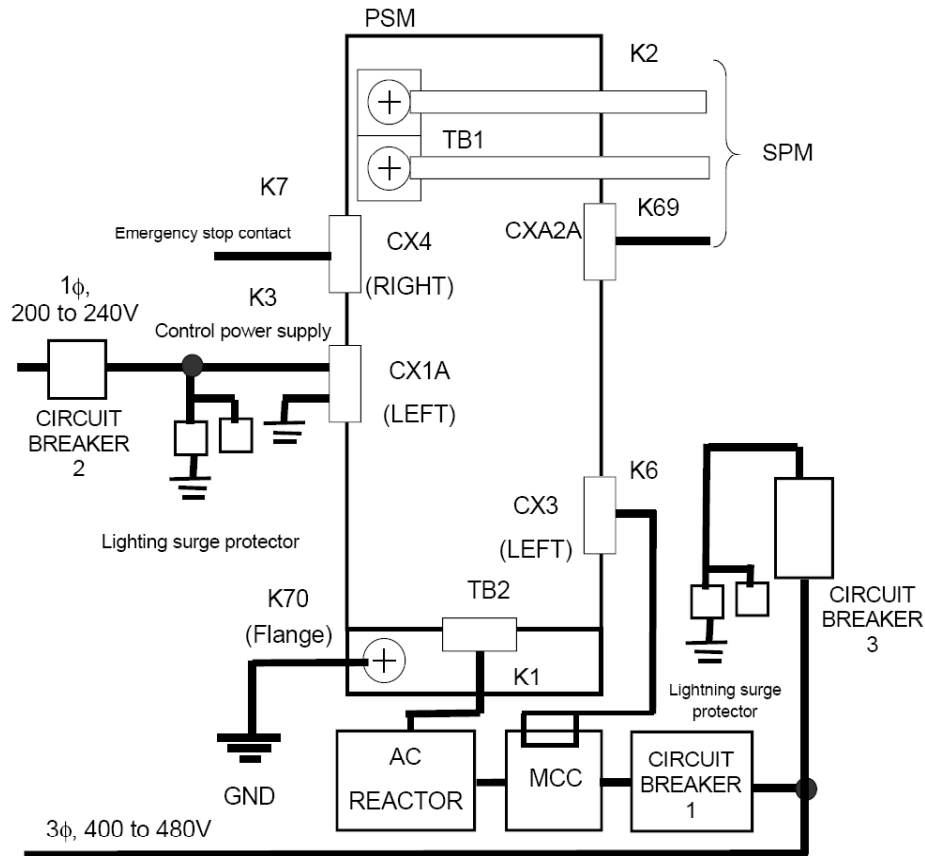

Notes:

1. Always install the circuit breakers, magnetic contactor, and AC reactor.
2. To protect the equipment from lightning surge voltages, install a lightning surge protector across each pair of power lines and across each power line and the grounding line at the power inlet of the power magnetics cabinet. For details, see "Grounding" on page IV-37.
3. Always connect the control power supply cable to the CX1A connector. If it is connected to the CX1B connector, fuses inside the unit may blow.
4. See "Details of Cable K70 – Ground Connection" on page IV-84 for the type of the cable to be used for making a connection to a frame ground.

Figure IV-32. PSM 400V-Input Series Connection Diagram

Servo Products Specification Guide

Cable Connections Summary

Table IV-31. System Connection Cables Summary

Ref.	Connects	GE Intelligent Platforms Cable Part Number	When Required
K1	Main power to PSM	Customer supplied	Always
K2	DC Link	See page IV-66 for details.	Always
K3	Control power to the PSM	Customer supplied. See page IV-68 for details.	Always
K4	Dynamic Brake Module	Customer supplied. See page IV-69 for details.	SVM-180i only
K6	Control signal for external magnetic contactor (MCC)	Customer supplied. See page IV-70 for details.	Always
K7	Emergency stop signal to the PSM	See page IV-71 for details.	Always
K21	Output power to Servo Motor	Customer supplied. See page IV-72 for details.	Always
K22	Serial Encoder feedback	Customer supplied. See page IV-75 for details.	Always
K24	Dynamic Brake Interlock Signals	Customer supplied. See page IV-77 for details.	SVM-180i only
K25	Dynamic Brake Driving Coil	Customer supplied. See page IV-78 for details.	SVM-180i only
K26	Power to Dynamic Brake Module	Customer supplied. See page IV-78 for details.	SVM-180i only
K27	FSSB interface	See page IV-79 for details.	Always
K28	Built-in Battery	Customer supplied. See page IV-80 for details.	Always
K69	Optional External Absolute Encoder Battery Connection	Customer supplied. See page IV-81 for details.	When external absolute encoder operation is required
K70	Protective ground	Customer supplied. See page IV-84 for details.	Always

33.8 Cable Details

Details of Cable K1 – AC Power to PSM-HVi Power Supply

Cable K1 is used to supply main power to the power supply module.

Make sure that the cable used between the power supply and power supply module satisfies the requirements listed below.

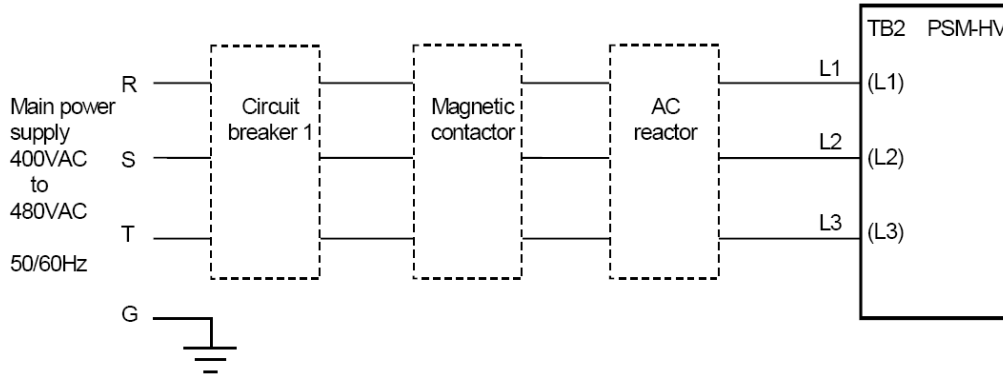

Cable K1 Specifications

<i>Model</i>	<i>Heavy Duty Power Cable (Note 1)</i>	<i>Heat Resistant Cable (Note 2)</i>	<i>Terminal Screw</i>	<i>Tightening Torque</i>
PSM-11HVi	5.5 mm ² minimum	5.5 mm ² minimum	M4	1.1 to 1.5 Nm
PSM-18HVi	NA	8 mm ² minimum	M4	1.1 to 1.5 Nm
PSM-30HVi	NA	14 mm ² minimum	M6	3.5 to 4.5 Nm
PSM-45HVi	NA	22 mm ² minimum	M6	3.5 to 4.5 Nm

Notes:

- 1) Four-conductor polyvinyl heavy-duty power cable (JIS C3312) (VCT: heat-resistant 60°C)
- 2) Fire-retardant polyflex wire (heat-resistant 105°C) or equivalent to LMFC manufactured by The Furukawa Electric Co., Ltd.
- 3) The cross-section area of each cable is determined under the following conditions:
 At PSM rated output
 Ambient temperature of cable: 30°C
 Number of harnesses: 3 (No current flows through the ground wire during normal operation.)
- 4) Select the required cable cross-section area according to the user environment and conditions.

Details of Cable K2 - DC Link Bus Bars

A set of bars is used to supply the DC link voltage generated in each power supply module to the connected amplifier. When designing a bus bar for connecting modules placed close to each other, refer to "Specifications of bus bars for connecting modules placed close to each other."

To determine the length of the bus bars to be used for connecting modules placed separately, refer to "Location of Terminal Board on Each Module."

For convenience, bus bar kits are available from GE Intelligent Platforms. Part numbers for these kits are shown in the table below.

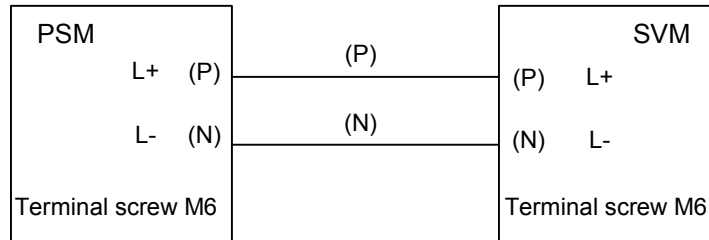

Specifications of bus bars for connecting modules placed close to each other

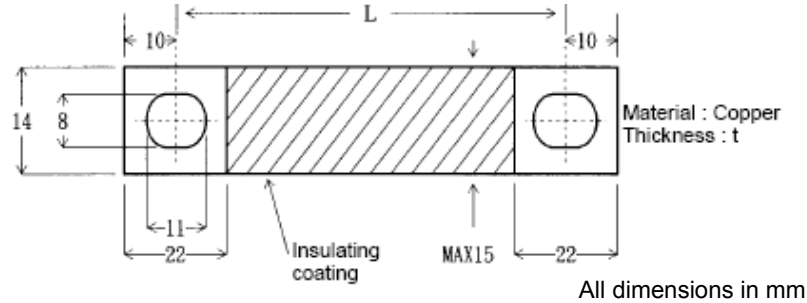

Bus Bar Specifications

Module Width	Bus Bar Length (L)	Bus Bar Thickness (t)	Cross-Section Area*	Bus Bar Kit Part Number
150mm	150mm	1.5mm	21mm ²	Z44A718031-G12
90mm	90mm	1.5mm	21 mm ²	Z44A718031-G03
60mm	60mm	1.5mm	21 mm ²	Z44A718031-G05

* If the modules cannot be placed close to each other, they do not need to be connected with a bus bar (copper plate). If you connect them with a power cable, the cable may not be thinner than the recommended cross-section area and must be insulated with heat-resistant polyvinyl.

Servo Products Specification Guide

Location of Terminal Board on Each Module

The figure below shows the location of terminal board TB1 on each module.

If you want to install modules at distances not specified herein, design bus bars or power cables for the DC Link connection by referring to the dimensions shown below.

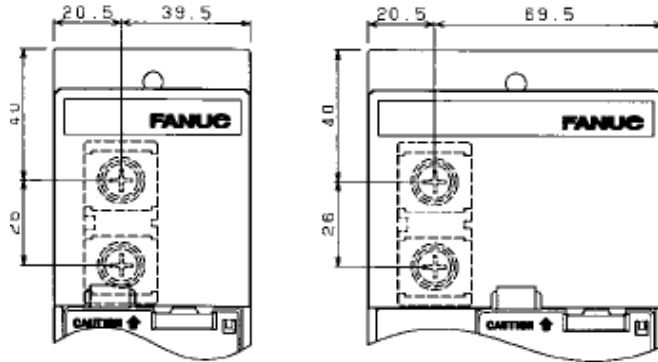

60mm-Wide Module
 α SVM1-40HVi; α SVM1-80HVi

90mm-Wide Module
PSM-11HVi; PSM-18HVi

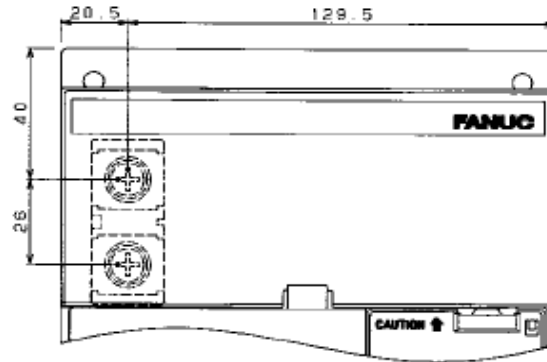

60mm-Wide Module
 α SVM1-180HVi; PSM-30HVi;
PSM-40HVi

All dimensions in mm

Servo Products Specification Guide

Details of Cable K3

Cable K3 is used to supply control power to the power supply module.

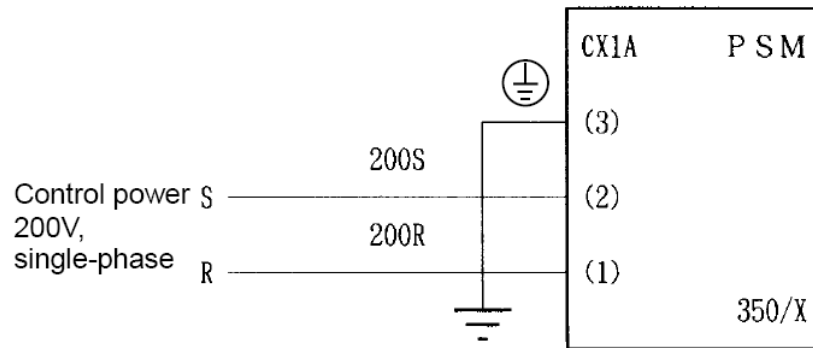

Cable Specification

Two-conductor polyvinyl heavy-duty power cable (JIS C3312)

Conductor size: 1.25 mm² (50/0.18),

PVC sheath: 9.6 mm diameter

Connector Specification

Tyco Electronics AMP connector

Receptacle housing: 1-178128-3

Receptacle contact: 1-175218-2

Servo Products Specification Guide

Details of Cable K4 – Dynamic Brake Module Power (SVM1-180HVi Amplifier Only)

Cable K4 is a connection cable used to supply power (single phase, 200 VAC) for driving the dynamic brake unit connected to an SVM1-180 HVI amplifier.

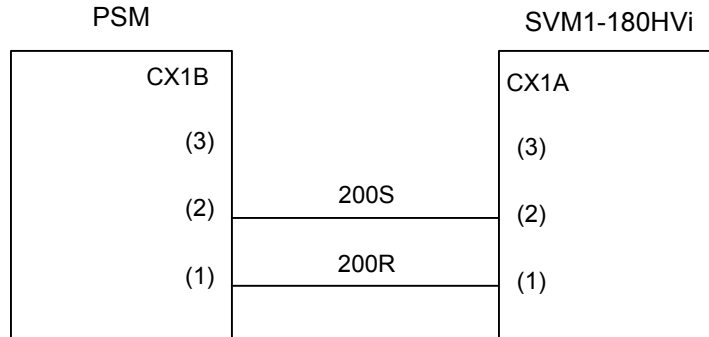

Sample Cable

Two-conductor polyvinyl heavy-duty power cable (JIS C3312)

Conductor size: 1.25mm² (50/0.18)

PVC sheath: 9.6 mm in diameter

Connector Specification

Tyco Electronics AMP connector

Receptacle housing: 1-178128-3

Receptacle contact: 1-175218-2

GE Intelligent Platforms Part Number: ZA02B-0120-K321 (two required)

Details of Cable K6

Cable K6 is used to control the magnetic contactor (MCC) if it is installed outside the unit.

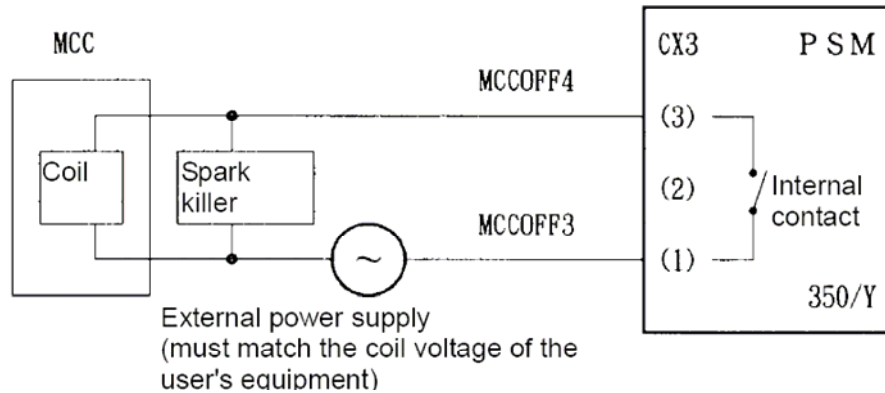

Cable Specification

Two-conductor polyvinyl heavy-duty power cable (JIS C3312),

Conductor size: 1.25 mm² (50/0.18)

PVC sheath: 9.6 mm diameter

Connector Specification

Tyco Electronics AMP connector

Receptacle housing: 2-178128-3

Receptacle contact: 1-175218-2

Internal Contact Specification

	Resistive load ($\cos\phi=1$)	Inductive load ($\cos\phi=0.4, L/R=7msec$)
Rated load	250VAC, 5A / 30VDC, 5A	250VAC, 2A / 30VDC, 2A
Maximum contact rating	5A	5A

Note: Always install a spark killer (CR) that matches the magnetic contactor to protect the internal contacts. The following table lists the recommended capacitances and resistances.

Coil voltage	Capacitance	Resistance
24VDC	0.22 μ F	22 Ω
100 to 230VAC	0.1 μ F	220 Ω

Details of Cable K7 – Power Supply Emergency Stop

Cable K7 is used to supply an emergency stop signal to the power supply module. To provide an emergency stop signal to an amplifier, refer to page IV-85.

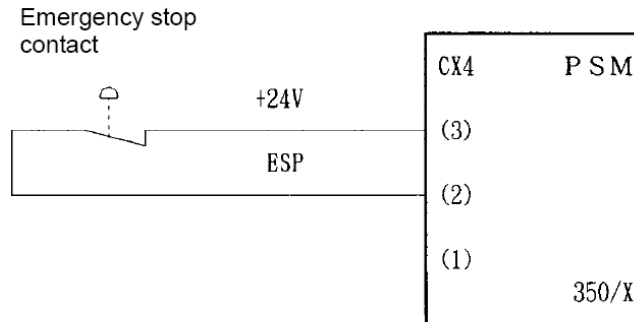

Cable specification

Two-conductor polyvinyl heavy-duty power cable (JIS C3312)

Conductor size: 1.25 mm² (50/0.18)

PVC sheath: 9.6 mm diameter

Connector specification

Tyco Electronics AMP connector

Receptacle housing: 1-178128-3

Receptacle contact: 1-175218-2

1. When the contact is ON (closed), the motor is enabled.

When the contact is OFF (open), the external magnetic contactor (MCC) is in the off state, and the servo motor does not operate.

2. When the contact is OFF (open) during motor rotation, the servo motor is stopped by the dynamic brake.
3. The contact input signal is specified as follows:
 - External contact capacity must be a voltage of at least 30 VDC and a current of at least 100 mA.
 - Levels (with the voltage between input pins) when the contactless signal input mode is used:
 - Low level "logic 0": Up to 2 V
 - High level "logic 1": At least 20 V
4. When the PSM main power is turned off for safety, for example when the machine protection door is open, the contact of the ESP signal (CX4), which is input to the PSM, must be set to OFF (open) within 200 ms after turn-off of the PSM main power. When the contact of the ESP signal (CX4) remains ON (closed) after the PSM main power is turned off, a DC link low-voltage alarm (alarm No. 4) occurs in the PSM.

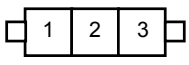
Connector	GE Intelligent Platforms Part No.	Manufacturer
Servo Amplifier CX4	ZA02B-0120-K321 (included with amplifier packages)	AMP Housing: 1-178128-3; Contact: 1-175218-2 (crimp terminal)  Connector viewed from wire insertion side.

Details of Cable K21 – Motor Power to α SVM1-40HVi and α SVM1-80HVi Amplifiers

The cable K21 is a power cable used between the SVM amplifier and motor. The cable is attached to the SVM through the D-5000 series connector (ZA06B-6110-K203#ZZN).

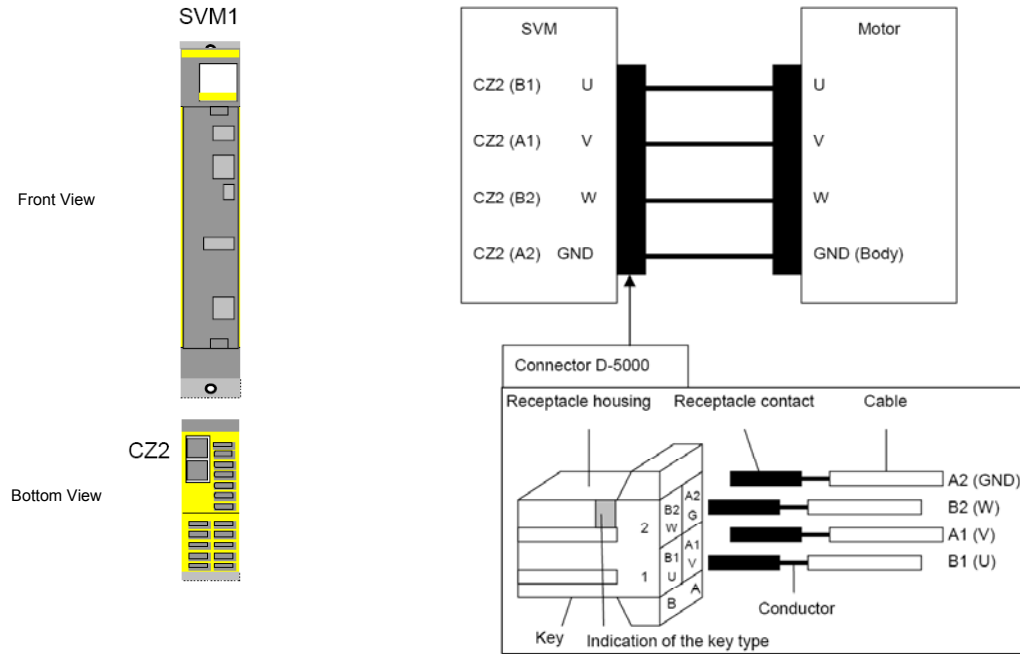

Note: When the α HVi series amplifier is used, always mount the motor so that it is connected to the system ground. If it is not possible to connect the motor flange to the system ground, connect the motor flange and frame ground (ground plate of the cabinet) using a cable at least 1.25 mm² thick. The cable must be separated from the power lines as much as possible.

SVM1 Amplifier CZ2 Motor Power Connector

Specification of the D-5000 for SVM1 Amplifiers

Receptacle Housing: 1-917807-2

GE Intelligent Platforms Part Number: ZA06B-6110-K203#ZZ

The CZ2 connector uses an SS size contact.

Contact model number	Conductor size (mm ²)	Conductor size AWG	Insulation outer diameter (mm)	Manual tool model number
SS size 1318986-6	0.50 – 1.42	20/18	1.08-3.23	1366656-1

Servo Products Specification Guide

Cable Considerations

Consider the following conditions for use when selecting the motor power cable.

1. Motor current rating or actual current needed for motor loaded based on application requirements.
2. Cable type (heat resistance temperature, etc.)
3. Environment in which the cable is installed (operating ambient temperature, etc.).
4. Need for waterproofing. (Note the diameter of the applicable cable clamp.)
5. Certification for CE marking (compliance with various safety standards and EMC standard)
6. Securing insulation space among the cable pins at the time of cabling

Motor Connector

The specification of the motor power connector varies from one motor model to another.

Refer to “Motor Power Connectors on page IV-51 for motor power connector part numbers.

Details of Cable K21 – Motor Power to α SVM1-180HVi Amplifier

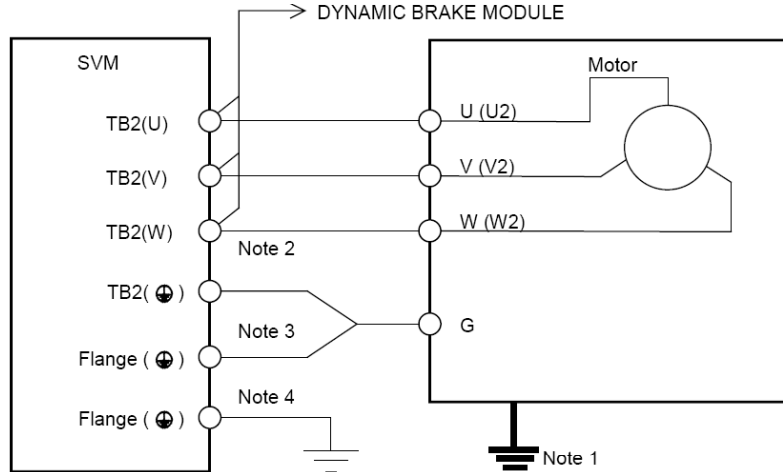

Notes:

1. When the α HVi Series amplifier is used, always mount the motor so that it is connected to the system ground. If it is not possible to connect the motor flange to the system ground, connect the motor flange and frame ground (ground plate of the cabinet) using a cable at least 1.25 mm² thick. The cable must be separated from the power lines as much as possible.
2. Size of screw for motor power line TB2 (U), TB2 (V), and TB2 (W): M6
3. Size of screw for motor ground lead TB2 (G): M6
4. Size of screws for connection between motor flange and ground: M5

Details of Cable K22 – Motor Serial Encoder Feedback

The cable K22 is used to connect the αSVM amplifier and motor serial encoder.

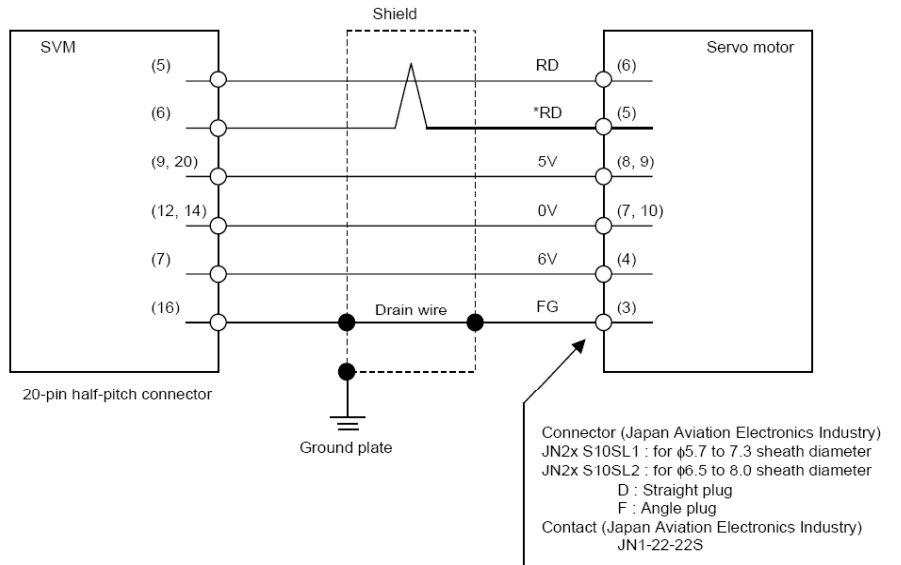

Cable Conductors

Signal name	Cable length: 28m or less	Cable length: 50m or less
5V, 0V, 6V	0.3mm ² × 5 Strand configuration 12/0.18 or 60/0.08 Insulation outer diameter φ0.8 to φ1.5	0.5mm ² × 5 Strand configuration 20/0.18 or 104/0.08 Insulation outer diameter φ0.8 to φ1.5
RD, *RD	0.18mm ² or more Twisted-pair wire Insulation outer diameter φ0.8 to φ1.5	0.18mm ² or more Twisted-pair wire Insulation outer diameter φ0.8 to φ1.5
Drain wire	0.15mm ² or more	0.15mm ² or more

Notes:

- The ground plate to which the shield is connected must be placed as close as possible to the servo amplifier so that distance between the ground plate and the servo amplifier is minimized.
- The total resistance of the complete wiring run, comprised of the 5V and 0V lines, must be less than 2Ω. Higher resistance will reduce the supply voltage to the serial encoder, possibly resulting in unreliable operation of the encoder.
- The encoder connector can accept a maximum wire size of 0.5mm² (wire construction 20/0.18 or 104/0.08, diameter Φ1.5 or less) wire and sheath diameter is Φ5.7 to Φ8.0. When using thicker wire or cable, take the measures described below.

[Case 1] Cable conductor exceeds 0.5mm².

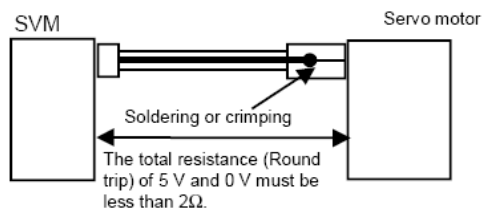

[Case 2] Sheath diameter of exceeds φ8.

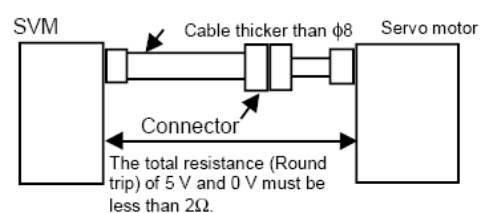

Servo Products Specification Guide

Crimp tool part numbers:

A06B-6114-K201/JN1S: For 0.3 mm²

A06B-6114-K201/JN1L: For 0.18 mm² or 0.5 mm²

GE Intelligent Platforms part numbers for connector kits:

ZA06B-6114-K204#S: Straight plug (kit includes contacts)

ZA06B-6114-K204#E: Elbow plug (kit includes contacts)

Amplifier JF1 Details

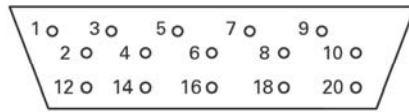

alphaHV Amplifier (JF1)

<i>Description</i>	<i>JF1 Pin Assignments</i>
N/C	1—4, 8, 10, 11, 13, 15, 17—19
N/C	
RD	5
*RD	6
+5 VDC	9, 20
0 VDC	12, 14
+6 VA (battery)	7
Frame Ground	16
Cable Shield	16

Details of Cable K24 – Dynamic Brake Module Interlock Signals

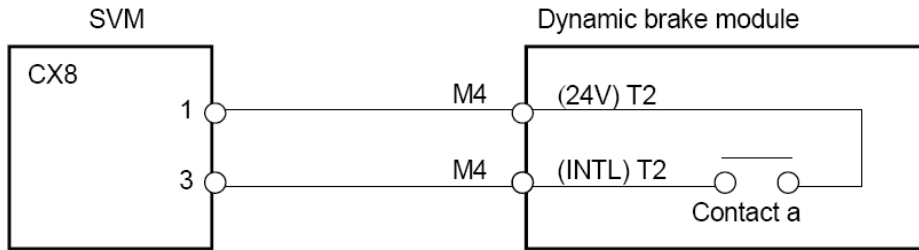

Example cable:

Two-conductor polyvinyl heavy-duty power cable (JIS C3312)

Conductor size: 1.25mm² (50/0.18)

PVC sheath 9.6 mm in diameter

Connector specification:

Tyco Electronics AMP connector with receptacle housing

2-178128-3 and receptacle contact 1-175218-2

Crimping terminal: 2-4

GE Intelligent Platforms part number: ZA06B-6073-K216

Details of Cable K25 – Dynamic Brake Driving Coil

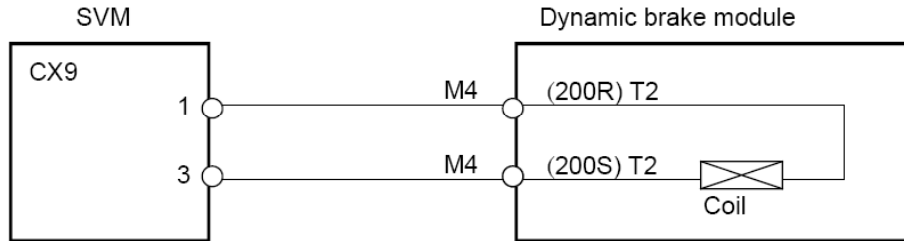

Example cable:

Two-conductor polyvinyl heavy-duty power cable (JIS C3312)
 Conductor size of: 1.25mm² (50/0.18)
 PVC sheath 9.6 mm in diameter

CX9 Connector specification:

Tyco Electronics AMP connector with receptacle housing
 1-178128-3 and receptacle contact 1-175218-2
 Crimping terminal: 2-4
 GE Intelligent Platforms part number: ZA06B-6073-K216

Details of Cable K26 – Power to Dynamic Brake Module

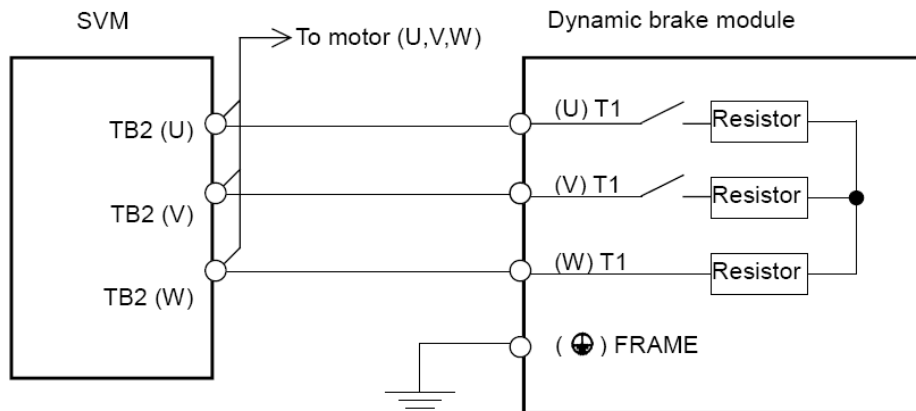

Example cable:

Fire-retardant polyflex wire (maximum conductor temperature 105°C) or equivalent to LMFC
 manufactured by The Furukawa Electric Co., Ltd., 5.5 mm² or larger
 TB2 screw terminal size: M6

Servo Products Specification Guide

Details of Cable K27 - FSSB Fiber Optic Servo Command Interface Cable

The optical cable is available in various lengths and is used to interface up to four amplifiers to the DSM324i or PACMotion controller. Additionally the fiber optic cables come in two styles.

Cable Type	Length*	Part Number
PVC Covered Fiber Optic Cable (use in sealed cabinet only)	0.15 meter	ZA66L-6001-0023#L150R0
	0.30 meter	ZA66L-6001-0023#L300R0
	1 meter	ZA66L-6001-0023#L1R003
	3 meter	ZA66L-6001-0023#L3R003
Sheathed Fiber Optic Cable*	1 meter	ZA66L-6001-0026#L1R003
	2 meter	ZA66L-6001-0023#L2R003
	3 meter	ZA66L-6001-0026#L3R003
	5 meter	ZA66L-6001-0026#L5R003
	10 meter	ZA66L-6001-0026#L10R03
	20 meter	ZA66L-6001-0026#L20R03
	30 meter	ZA66L-6001-0026#L30R03
	50 meter	ZA66L-6001-0026#L50R03
	100 meter	ZA66L-6001-0026#L100R3

*Longer lengths are available but are not stocked.

WARNING

GE Intelligent Platforms cannot guarantee the servo performance and reliability unless the fiber optic command interface cable meets or exceeds the stated specifications.

FSSB Cable Specifications

Connector maker: Tyco Electronics AMP. Parts list:

Connector Part	Vendor Part Number
Ferrule	316892
Housing	316890
Stopper	316891
Spring	900357

- Cable material must be Multi-mode
- Cable loss (max.): 3dB
- The transmission rate is 25Mbps.
- The fiber used is plastic clad silica fiber. The core diameter is 200 micrometer, and the plastic clad diameter is 230 micrometer.
- The initial loss is 0.015dB per meter (At room temperature).
- The type of light is LED. The wavelength of light is 650nm.
- Bend radius minimum: 50mm.
Life: ~10 million cycles at 100mm radius, @ +/- 90 degrees .
- Twist angle maximum: 360 degrees.
Life: 900,000 cycles @ +/- 180 degrees twisting.
- The cable must be clamped so that no stretching force is applied and no forces within 200mm (8 inches) of connector.

Servo Products Specification Guide

FSSB Cable Connections

Each αHVi Series amplifier has two FSSB connectors labeled C0P10A and C0P10B. Connector C0P10A is an optical transmitter and C0P10B is an optical receiver. Proper system operation requires that the FSSB cables be installed on the proper connector as shown below.

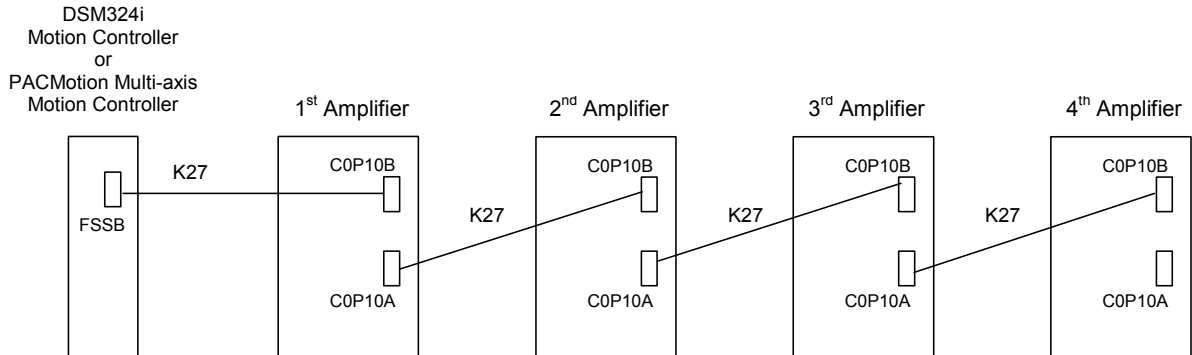

Details of Cable K28

Cable K28 is used to connect the single-axis lithium battery, which is used to power the absolute serial encoder on the motor when power is removed from the SVM amplifier. This cable and connector is part of the lithium battery assembly included in the IC800ABK002 and IC800ABK003 battery kits.

Details of Cable K69 – PSM Interface to SVM Amplifiers

The cable K69 is used between the PSM and SVM when supplying power from one IC800ABK001 multi-axis encoder battery unit to more than one SVM amplifier. This cable interface is also used to supply 24VDC power from the PSM power supply module to all connected SVM amplifiers. Additionally, all connected SVM amplifiers can share a system emergency stop (ESP) signal.

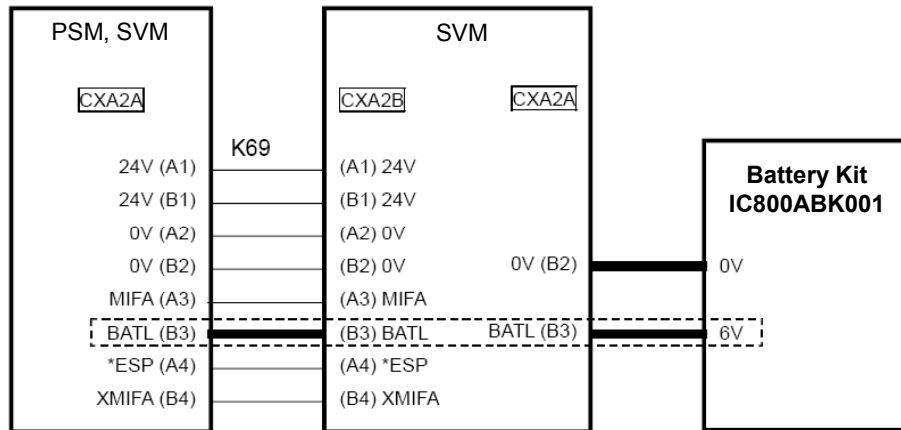

Figure IV-33. PSM Interface Connection Between Modules

Battery Interface

The BATL (B3) pin is an interface for supplying power from one absolute Encoder battery unit to more than one SVM amplifier.

Warning

When using the built-in battery (IC800ABK002 or IC800ABK003), never connect the BATL(B3) of the connector CXA2A/CXA2B. Otherwise, a short-circuit will occur between the battery output voltages for different SVMs, possibly resulting in the batteries becoming very hot, which is dangerous.

Do not connect more than one IC800ABK001 multi-axis battery kit to the same BATL(B3) line. Otherwise, a short-circuit will occur between the output voltages of different batteries, possibly resulting in the batteries becoming very hot, which is dangerous.

Up to six servo motors can be connected to one battery. The life of the batteries is about two years if they are used for six ai series servo motors.

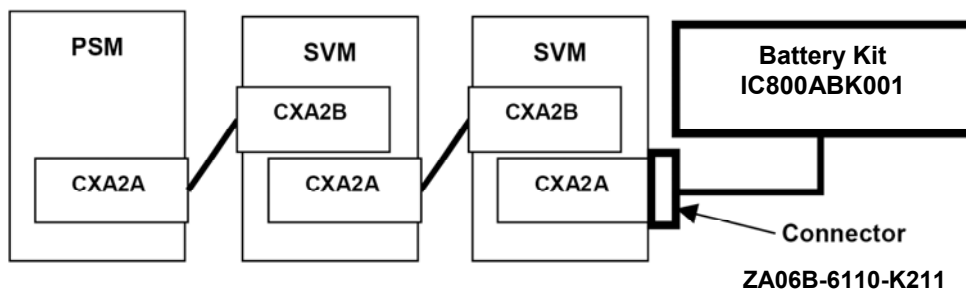

Figure IV-34. Supplying Power from One Battery to Multiple Amplifiers

Servo Products Specification Guide

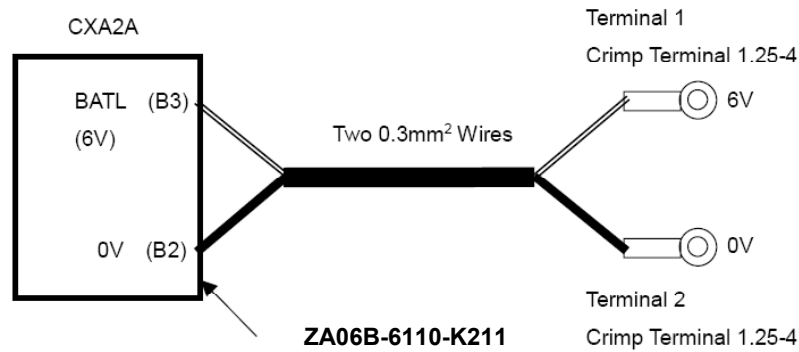

Figure IV-35. Connection Between IC800ABK001 Battery Unit and SVM Amplifier

Table IV-32. CXA2A/CXA2B Connector and Cable Options for K69

<i>Option</i>	<i>Part Number</i>
Connector only	ZA06B-6110-K210
200mm cable with connector for use with IC800ABK001 battery backup kit	Z44C746453-001
200mm cable with connectors for use with IC800ABK002 or IC800ABK003 battery backup kit, or no battery	Z44C746453-002

Table IV-33. ZA06B-6110-K210 Connector Specification

This connector is required when building cable K69.

<i>Manufacturer</i>	<i>AMP Japan, Ltd</i>
Connector Specification	D-2100 series Housing 1-1318119-4 (quantity: 1) Contact 1318107-1 (quantity: 8) GE Intelligent Platforms part number: ZA06B-6110-K210 (connector only)
Conductor size	0.5mm ² , AWG20
Insulation outer diameter	1.08–2.83mm

Servo Products Specification Guide

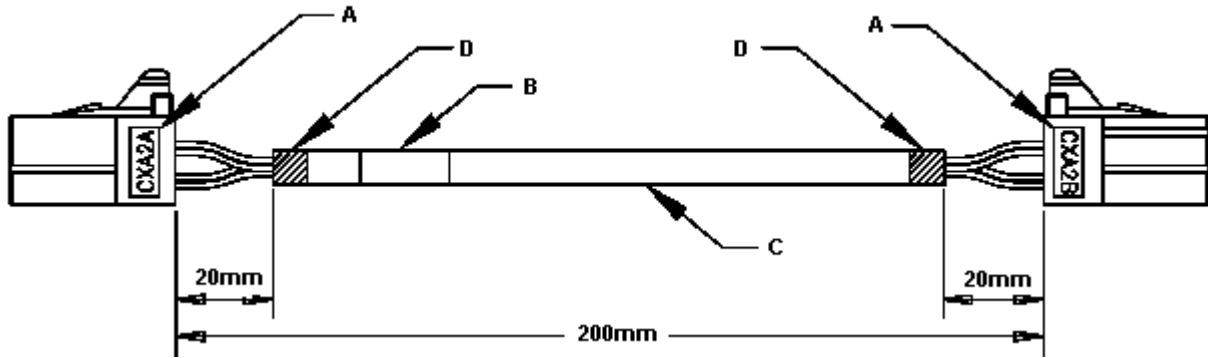

A	ZA06B-6110-K210 connectors.
B	Mark cables with date, part number and revision number. Cable markings should be permanent, smear-proof and oil proof.
C	Cable type: 20 AWG, stranded CU, 80°C, 300V, 8 conductor, PVC jacket, Alpha 5058C or equivalent. Unused ends should be cut at cable jacket.
D	Heat shrink tubing, 0.5".

CXA2A/CXA2B Pin	Signal		Function
	Z44C746453-001 Cable	Z44C746453-002 Cable	
A1	24V	24V	24V power from PSM to SVM
A2	0V	0V	
B1	24V	24V	24V power from PSM to SVM
B2	0V	0V	
A3	MIFA	MIFA	Encoded power supply alarm signal
B3	BATL	No connection	Battery interface
A4	ESP	ESP	Emergency stop
B4	XMIFA	XMIFA	Encoded power supply alarm signal

Figure IV-36. CXA2A/CXA2B Connector and Cable Details

Details of Cable K70 – Ground Connection

Connect the SVM mounting flange to the cabinet grounding plate through a grounding cable (protective ground connection).

Cable K70 is used for the following ground connections:

- a. Connector CX1A on the power supply module to the frame ground of the cabinet. Conductor size: 1.25 mm².
- b. The metal frame of the power supply module to the frame ground of the cabinet.
- c. The metal frames of the servo amplifier module to the frame ground of the cabinet.
- d. The cable K70 is used to connect the metal frame of the dynamic brake module (DBM) to the frame ground of the cabinet. Select the size of the cable according to the following table. The cross-section size of the motor power cable listed in the table complies with the conductor diameter of the motor power cable used in a unit to which the DBM is connected.

Table IV-34. Grounding Cable Conductor Diameter

<i>Motor power cable cross-section S (mm²)</i>	<i>Grounding cable cross-section (mm²)</i>
S ≤ 5.5	5.5 or greater
5.5 < S ≤ 16	S or greater
16 < S ≤ 35	16 or greater
35 < S	S/2 or greater

Note: The following M5 crimp terminal can be used with a cable having a large conductor diameter.

Nichifu Co., Ltd. CB22-5S

Overall conductor size range: 16.78 to 22.66 mm²

Safety Relay Wiring and Operation

The wiring shown in this section allows you to disconnect motor power to a single axis. This wiring applies only to the following amplifiers:

- αSVM1-10HVi (ZA06B-6127-H102)
- αSVM1-20Hvi (ZA06B-6127-H103)
- αSVM1-40Hvi (ZA06B-6127-H104)
- αSVM1-80Hvi (ZA06B-6127-H105)

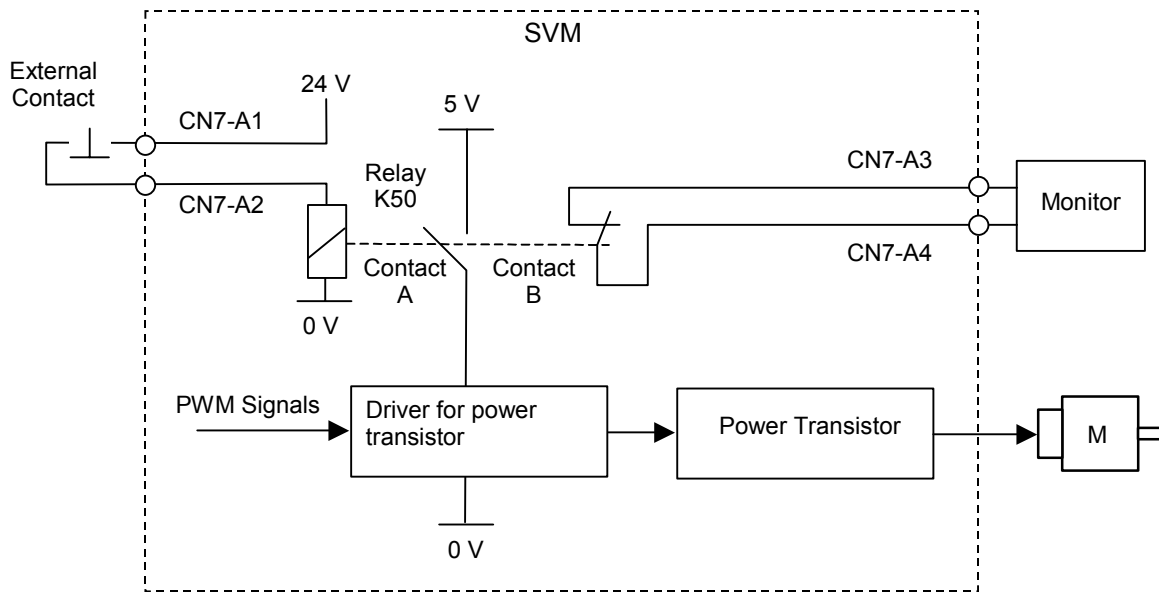

Figure IV-37. PSM Interface Connection Between Modules

Safety Relay Operation

- The safety relay K50 operates by an external contact signal.
- Contact A of relay K50 cuts off the power supply of the drive for the motor power output transistor.
- Contact B of relay K50 is used to monitor the relay status.

Operation of the Circuit

When the external contact closes, contact A of relay K50 closes. The power supply of the driver for the power transistors turns on, enabling power to the motor. Contact B is open in this state.

When the external contact is open, contact A cuts off the power supply of the driver for power transistors, and the power transistors are forced off, disabling power to the motor. Contact B closes in this state.

Contact B can be used to monitor the state of the circuit. If the state of the circuit is not monitored, there is a possibility that the motor could be energized unexpectedly.

This function does not satisfy the requirement for safety standard by itself. Users should implement the proper safety circuit according to the safety standard required.

Servo Products Specification Guide

Connector Interface

The safety relay drive and the monitor contact are accessed on connector CN7, located on the bottom of the amplifier, as shown below.

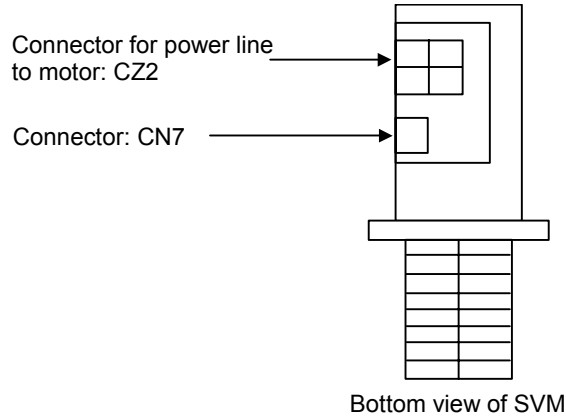

Connector CN7 Specification

Manufacturer	Tyco Electronics AMP
Specification	D2100 Series
	Housing: 1-1318119-4
	Contact: 1318107-1

Pin Assignments for Connector CN7

Pin No.	A4	A3	A2	A1
Name	AS2	AS1	DOFEX	24V
Pin No.	B4	B3	B2	B1
Name	–	–	–	24V

Specifications for the Coil and Contact B of Relay K50

Input voltage of the coil	20.4V–26.4V
Rating of the contact	30VDC, 6A (resistance load)

Note: The dummy connector to short CN7-A1 and CN7-A2 is inserted at shipment. When you do not use this function, the dummy connector must be inserted. If the dummy connector is not installed, the motor cannot be operated. Take care not to short the 24V supply.

#

- α HVi Servo System
 - system connection, IV-48
- α i Servo System
 - system connection, IV-48
- α Servo System
 - Block Diagram, I-2, II-2
 - Package Options, I-8, II-10
 - Specifications, II-9
- α Servo system specifications, I-7
- α SVU Series, I-2
- α SVU1 Amplifier Connections, I-41
- βHVi Servo System
 - amplifiers, III-20
 - heat dissipation, III-39
 - installation, III-35
 - motor outline drawings, III-11
 - Overview, III-2
 - speed-torque curves, III-9
 - system connection, III-57
- βHVIs Servo System
 - Servo Motor Specifications, III-8
- βi Servo System
 - amplifiers, III-20
 - heat dissipation, III-39
 - installation, III-35, IV-32
 - motor outline drawings, III-11
 - Overview, III-2
 - Package Options, III-6, IV-4
 - Servo Motor Specifications, III-7
 - speed-torque curves, III-9
 - system connection, III-57

A

- Absolute Encoder Battery, I-10, II-11, III-29, IV-29
- AC line filter, II-26, III-44, IV-42
- AC power, I-30, I-33, II-26, II-28, III-44, III-46, IV-42, IV-46
- Alarm Functions, I-57, II-50, III-22, IV-22
- Amplifier Control Power, II-29, III-47
- Amplifier Package, α Series, I-6
- Amplifiers
 - α heat dissipation, I-12, II-13
 - βHVi heat dissipation*, III-37
 - βi and βHVi Models, III-4
 - βi heat dissipation*, III-37, IV-35
 - βSVM i connectors, III-72
 - Alarm Functions, I-21, I-57, II-19, II-50, III-22, IV-22
 - βHVi, III-23
 - βi, III-23
 - αHVi, IV-23
 - αi, IV-23

- Connector Kit, II-33
 - α Series, I-42, II-32
 - Environmental Requirements, I-11, II-12
 - Maintenance Clearances, II-13
 - Models, I-6, II-8, III-4
 - αHVi heat dissipation, IV-35
 - αi and αHVi kits, IV-3
 - αi and αHVi models, IV-3
- Axial Load, I-21, II-19

B

- Battery Packs, Encoder, I-10
 - βHVi series, III-29
 - βi series, III-29
 - αHVi series, IV-29
 - αi series, IV-29
- Battery, Packs Encoder, II-11
- Bearing, I-21, II-19
- Block diagram, I-2, II-2
- Brake, I-9
 - α Series motor, I-5, II-6
 - βHVi Series motor, III-16
 - βi Series motor, III-16
 - αHVi Series motor, IV-16
 - αi Series motor, IV-16
- Brake Power Supply, I-5

C

- Cables, α Series
 - K10-Emergency Stop/Power Enable Cable, I-54
 - K10-Emergency-Stop/Power Enable Cable, II-48
 - K11-Separate Regenerative Discharge Unit Fan Supply Cable, I-55
 - K12-24 VDC Amplifier Power Cable, II-48
 - K12-Motor Brake Power Connection, I-55
 - K13-24 VDC Power Daisy Chain Cable, II-49
 - K13-Cooling Fan Power Connection, I-56
 - K14-Motor Brake Power Cable, II-49
 - K1-Servo Command Signal Cable, I-45, II-36
 - K2-Motor Encoder Feedback Cable, I-47
 - K2-Motor Encoder Feedback Cable (β0.5/3000), II-38
 - K2-Motor Encoder Feedback Cable (β2/3000, β6/2000), II-39
 - K3-Three-Phase Servo Power Cable, I-48, II-41
 - K4-Motor AC Power Cable (β2/3000, β6/2000), II-43
 - K4-Motor Power Cable (β0.5/3000), II-42
 - K4-Motor Power Cable (α12/3000, α22/2000), I-48

- K4-Motor Power Cable (α 30/3000, α 40/2000), I-50
- K4-Motor Power Cable (α 30/3000, α 40/2000), I-49
- K4-Motor Power Cable (α C 12/2000), II-44
- K5-Amplifier Stop Connection, I-51
- K5-Emergency Stop Connection, II-45
- K6-Amplifier Control Power Connection, I-51
- K7-Regenerative Discharge Cable, II-46
- K7-Separate Regenerative Discharge Unit Power Cable, I-52
- K8-Regenerative Discharge Thermal Protection Cable, II-46
- K8-Separate Regenerative Discharge Unit Thermal Protection Cable, I-52
- K9-absolute encoder battery cable, II-47
- K9-Optional Absolute Encoder Battery Cable, I-53
- Motor Encoder Feedback Cable (α C12/2000, II-40 overview, I-43, II-34
- Cables, α HVi Series summary, IV-64
- Cables, β i and β HVi Series
 - K10, III-95
 - K2-AC power to β SVM1-20i Amplifier, III-80
 - K2-AC power to \square SVM1-40i Amplifier, III-81
 - K2-motor power to \square SVM1-40i Amplifier, III-83
 - K3-motor power to \square SVM1-20i Amplifier, III-82
 - K4, III-84
 - K6, III-90
 - K7, III-92
 - K8, III-93
 - K9, III-94
- Cables, β i Series
 - K1-motor serial encoder feedback, III-78
- Catalog Numbers
 - α Series, I-6
 - β Series, II-8
 - β i Series, III-4
- Circuit breaker, I-32, II-27, III-45, IV-44
- Clearances
 - Amplifier, I-12, II-13
- Connection
 - Details, I-45, II-36
- Connectors
 - β Series Motors, II-32
- Contact rating, I-32, II-27, III-45
- Control Power, I-33
- Crimp tools
 - for β Cx11 connectors, II-33

D

- DC power, II-29, III-47

Dimensions

- β Discharge units, III-50
- β Series amplifier, II-20
- α Series amplifier Panel cutouts, I-22
- α Series amplifiers, I-22
- α Series Regenerative D.U., I-38
- AC Line Filters, I-31
- Discharge Resistor, I-39
- Discharging regenerative energy, I-34, II-29, III-48
- Dissipation
 - Amplifier, I-12, II-13, III-37, IV-35
- Dynamic Braking Module, IV-26

E

Encoder

- Battery, I-10, II-11
 - β HVi series, III-29
 - β i series, III-29
 - α HVi series, IV-29
 - α i series, IV-29

Environmental requirements

- β amplifiers, II-12
- α amplifiers, I-11
- α Series, I-11, II-12
- β HVi amplifiers, III-36
- β HVi Series, III-35
- β i amplifiers, III-36
- β i Series, III-35
- Motors, I-11, II-12, III-35, IV-32
- α HVi amplifiers, IV-33
- α HVi Series, IV-32
- α i amplifiers, IV-33
- α i Series, IV-32

F

- Fuses, II-29, III-47

G

Ground fault interrupter

- α Series, I-29, II-25

Grounding

- α Series, I-26
- β Series, II-21
- β i and β HVi Series, III-40
- α i and α HVi Series, IV-37

- Grounding Clamp, I-28

H

Heat dissipation

- α Series, I-12
- β Series, II-13

βHVi, III-39
βHVi Series, III-37
 βi, III-39
βi Series, III-37
 αHVi, IV-36
 αHVi Series, IV-35
 αi, IV-36
 αi Series, IV-35
 High Response Vector function, I-4, II-4,
 III-9, IV-8

I

Installation Guidelines, I-11, II-12
 βHVi, III-35
 βi, III-35
 αHVi, IV-32
 αi, IV-32

L

Line filter, I-30, II-26, III-44, IV-42

M

Maintenance Clearances, II-13, III-37, IV-
 35
 Motor Dimensions
 β0.5/3000, II-14
 α12/3000, I-15
 β2/3000, II-15
 β2/3000 w/brake, II-17
 α22/3000, I-15
 α30/3000, I-15
 α40/2000, I-18
 β6/2000, II-15
 β6/2000 w/brake, II-17, II-18
 α6/3000, I-13
 αC12/2000, II-15
 αC12/2000 w/brake, II-17, II-18
 βM0.5/4000, II-18
 βM1/4000, II-18
 Motor outline drawings
 βHVi Servo System, III-11
 βi Servo System, III-11
 αHVi Servo System, IV-10
 αi Servo System, IV-10
 Motors, I-9
 Brake, I-5, I-9, II-6, III-16, IV-16
 Environmental requirements, I-11
 Environmental Requirements, II-12, III-35,
 IV-32
 Speed-Torque Curves, IV-8
 HRV function, I-4, II-4, III-9

N

Noise Protection
 α Series, I-26, II-21
 βHVi Series, III-40
 βi Series, III-40
 αHVi Series, IV-37
 αi Series, IV-37

O

Options
 α Series, I-8, II-10
 αi Series, IV-4
 βi Series, III-6
 Overview
 α Series, I-3, II-3
 βHVi Series, III-2
 βi Series, III-2
 α HVi Series, IV-2
 α i Series, IV-2

P

Package Options, I-8, II-10
 αi, IV-4
 βi, III-6
 Part Numbers
 α Series, I-6, II-8
 βHVi Series, III-4
 βi Series, III-4
 Power Line Protection, I-30, II-26, III-44,
 IV-42
 Power requirements
 α HVi Series, IV-42
 α HVi Series AC Power, IV-42
 α HVi Series Circuit Breakers, IV-44
 α i Series, IV-42
 α i Series AC Power, IV-42
 α i Series Circuit Breakers, IV-44
 α Series, I-30, II-26
 β Series AC Power, II-26
 α Series Circuit Breakers, I-32, II-27
 α Series Discharging Regenerative Energy,
 I-34, II-29
 α Series Electromagnetic Contactor, I-32, II-
 27
 α Series Incoming AC Power, I-30
 βHVi Series, III-44
 βHVi Series AC Power, III-44
 βHVi Series Circuit Breakers, III-45
 βHVi Series Discharging Regenerative
 Energy, III-48
 βHVi Series Electromagnetic Contactor, III-
 45
 βi Series, III-44

- β i Series AC Power, III-44
- β i Series Circuit Breakers, III-45
- β i Series Discharging Regenerative Energy, III-48
- β i Series Electromagnetic Contactor, III-45
 - AC power, I-33, II-28, III-46, IV-46
 - Incoming DC power, III-47
 - Incoming DC Power, II-29
- Power supplies, IV-27
- Protection
 - α Series, I-57, II-50
 - β HVi Series, III-22
 - β i Series, III-22

R

- Radial Load, I-21, II-19
- Regenerative Discharge Units
 - α Series, I-34
 - β Series, II-29
 - β i Series, III-48
- Regenerative energy, I-34
 - calculating for α Series, I-34, II-30
 - calculating for β i Series, III-55
- Regenerative Energy, II-29, III-48

S

- Safety relay wiring and operation
 - α HVi Series, IV-85
- Sealing Option, I-9
- Servo package options, I-8, II-10
 - β i, III-6
 - α i, IV-4
- Shaft Loading
 - α Series, I-21, II-19
- Specifications
 - α Series, I-7
 - β Series, II-9
- Speed-Torque curves
 - α Series, I-4, II-4
 - β HVi Series, III-9
 - β i Series, III-9
 - α HVi Series, IV-8
 - α i Series, IV-8
- Switch Settings, I-25, III-49

T

- Technical Support. See page iii
- Tools
 - for A06B-6110-K200#XXS connector, III-81
 - for A06B-6110-K202#YYs connector, III-83
 - for A06B-6130-K200 connector, III-80, III-82
- Tools, crimp
 - for β Cx11 connectors, II-33
- Transformer, I-30, II-26, III-44, IV-42

A

- α HVi Servo System
 - heat dissipation, IV-36
 - installation, IV-32
 - motor outline drawings, IV-10
 - Overview, IV-2
 - speed-torque curves, IV-8
- α HVis Servo System
 - Servo Motor Specifications, IV-6, IV-7
- α i Servo System
 - amplifiers, IV-22
 - motor outline drawings, IV-10
 - Overview, IV-2
 - Servo Motor Specifications, IV-5
 - speed-torque curves, IV-8
- α i Servo System
 - heat dissipation, IV-36