

K-Track

TRK500

TRK500-HD

Kawasaki Robotics 7th axis

Linear track with maximum capacity of 800kg

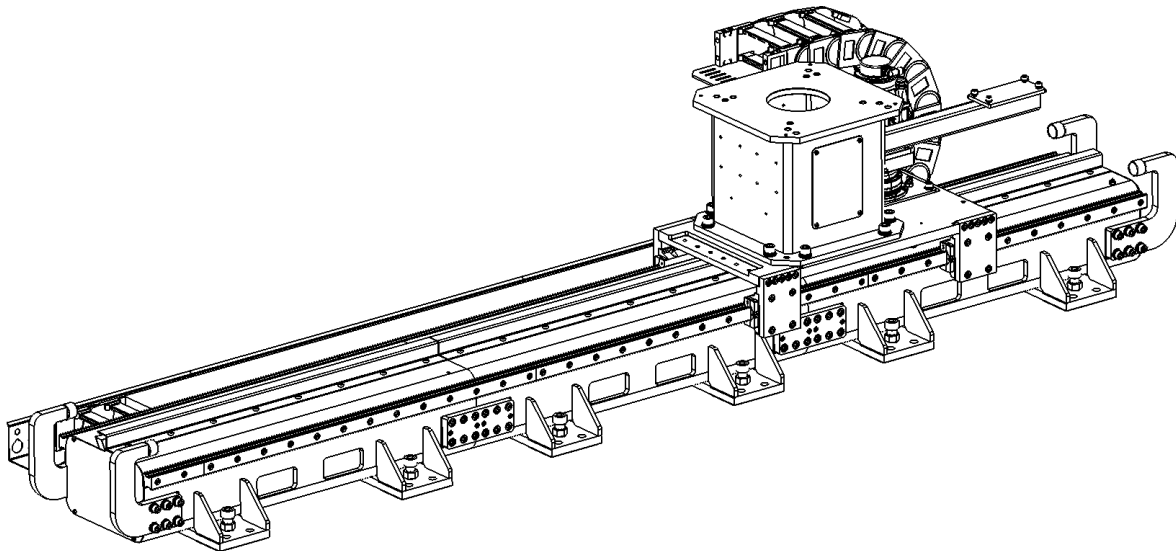

Contents:

1. Introduction	2
2. Technical parameters	3
3. External dimensions	4
4. Basic assembly of the basic module	5
4.1. Mechanical system	5
4.2. Electrical system	5
4.3. Cleaning station connector	6
5. Assembly and start-up	7
5.1. Assembly	7
5.2. Getting ready for operation	8
5.3. Emergency Stop connection	8
5.3.1. Cubic-S Option	8
5.4. Start-up	9
5.5. Working conditions and safe use.	9
5.6. Maintenance of the linear track	10
5.7. Maintenance schedule	10
6. Layout of user cables inside the structure	11
7. Storage and transport conditions	11
7.1. Storage	11
7.2. Transport	12
8. Safety information and residual risk	13
8.1. Danger due to mechanical construction	13
8.1.1. Crashing and cut-offs	13
8.2. Dangers due to the electrical system	13
8.3. Information about noise emission	13
9. Notes	14
10. Manufacturer's data	15

Appendix 1 - Spare parts list

Appendix 2 - Standard of cable terminations

1. Introduction

K-Track TRK500-HD linear track is an electrically driven unit. It is equipped with one rotary axis controlled in a continuous manner. It is designed to work in a robotic welding station and is used to move the robot or other equipment. It is controlled from the Kawasaki Robotics robot controller as additional axis.

All units are in International System of Units.

-
- I. These instructions do not constitute a guarantee of the system in which the linear track is installed. Accordingly, ASTOR company is not liable for any accidents, damages and/or problems related to industrial property rights arising as a result of using the system.
 - II. It is recommended that all personnel assigned to operating, teaching, servicing or maintaining the linear track attend the necessary courses when installing the system before commencing the performance of their duties.
 - III. ASTOR company reserves the right to alter, correct or update this manual without prior notice.
 - IV. Keep the following instructions with care and in a place where they can always be available for use. If the linear track is re-installed or relocated, please attach these complete and unaltered instructions. In case the instructions are lost or damaged, please contact ASTOR company.
-

2. Technical parameters of K-Track TRK500-HD linear track

Model	TRK500-HD
Maximum payload	800 kg
Max. speed	1.4 m/s
Max. capacity of the Robot	80kg
Min. travel distance	1200 mm
Max. travel distance	30 000 mm
Min. travel distance gradation	1000mm
Repeatability	±0.05 mm
Carriage mass	80 kg
Carriage mass with options	180 kg
Default height of robot assembly	285 mm*
Installation position	Floor/ceiling/wall
Environment conditions	5-40°C

*possibility of adding a robot pedestal:

- max. height 300mm
- min. height 100mm
- standard height 300mm

It is possible to equip the track with a lubrication system, detailed are described in the instructions:

K-Track_lubricaion_system

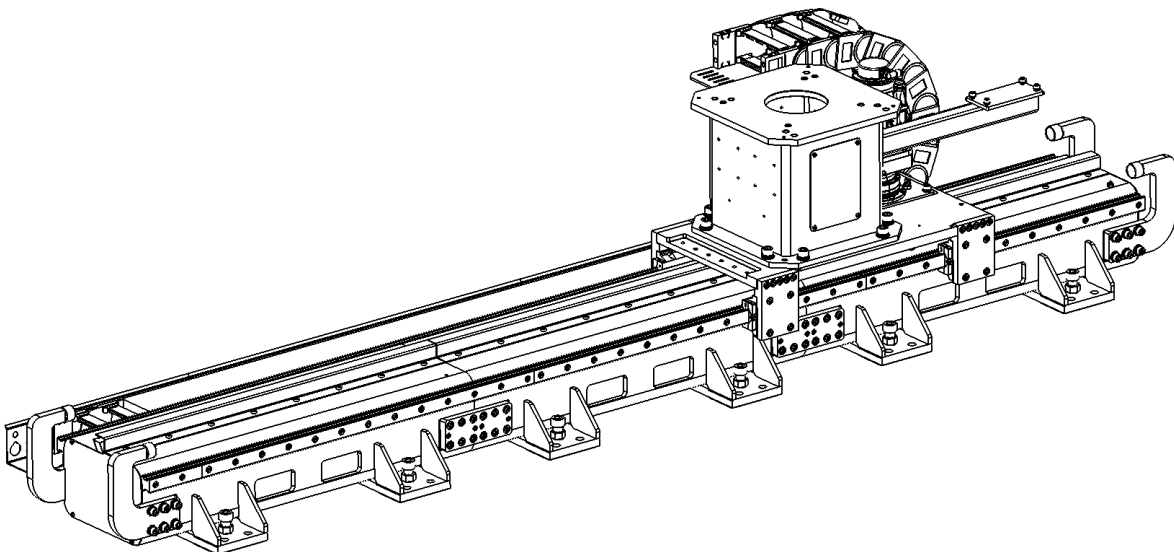

Linear track with robot pedestal

3. External dimensions

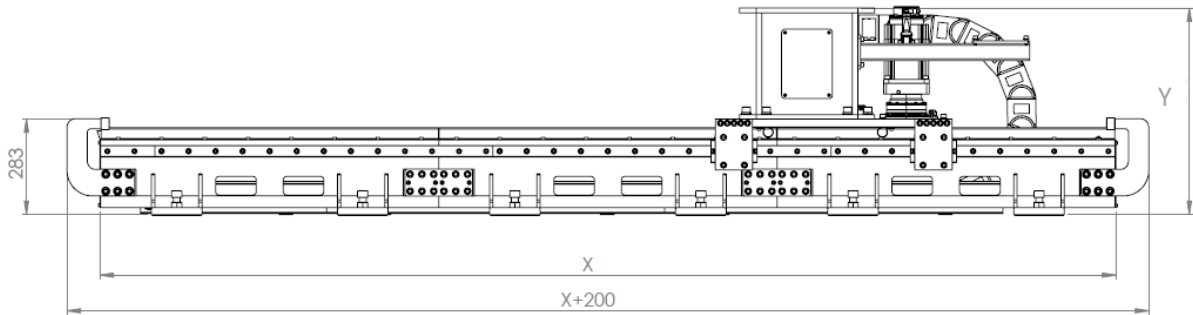

X – travel distance,
 Y- height from the floor, depending on the pedestal used

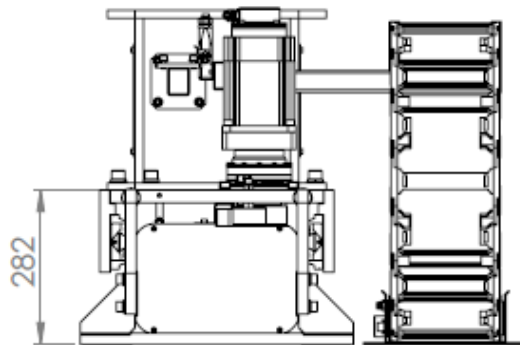
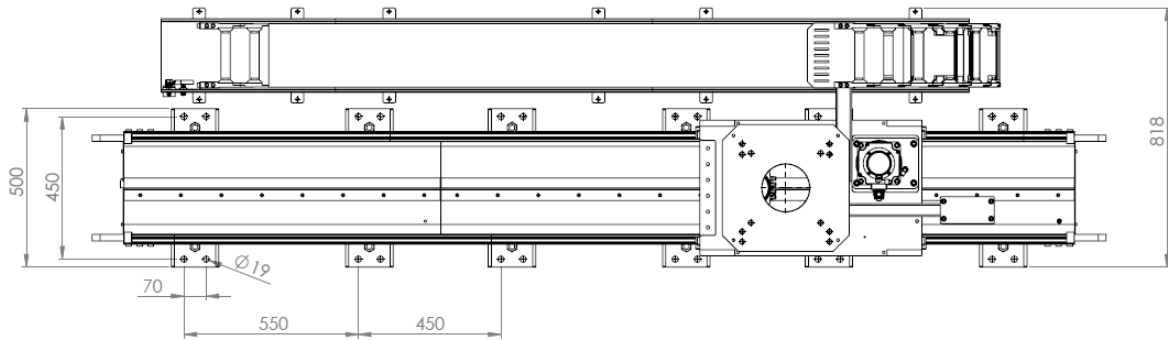

Fig. 1 Basic dimensions of the robot track with spacing of fixing holes.

4. Basic assembly of the basic module

4.1. Mechanical system

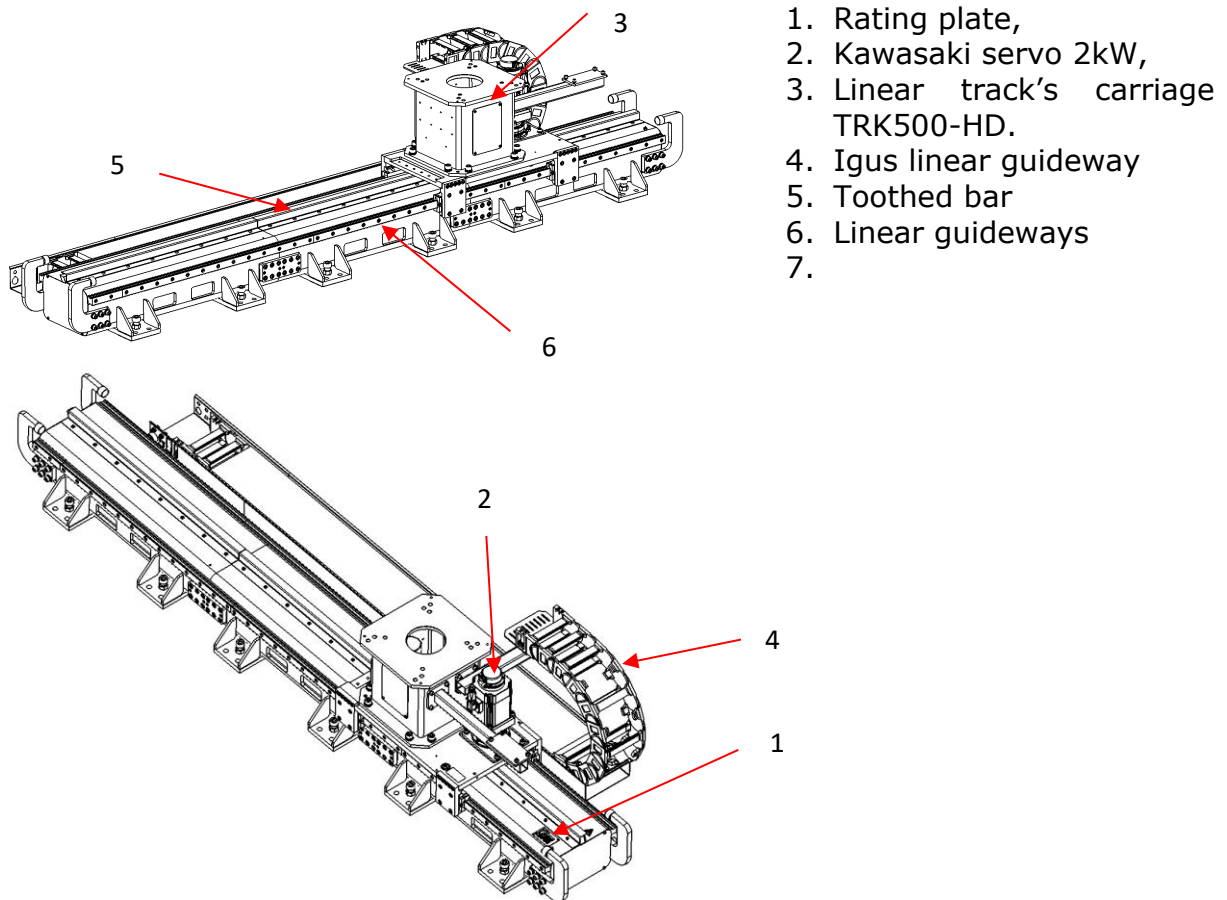

Fig. 2. Basic assembly of the basic module

4.2. Electrical system

The power units consist of:

Axis 1 (Linear move) Kawasaki Servo-Motor 2.0kW and planetary gearbox.

The axes are controlled as external axes from the robot control system. It is not possible to move the carriage without connecting it to the Kawasaki Robotics robot controller.

4.3. Cleaning station connector

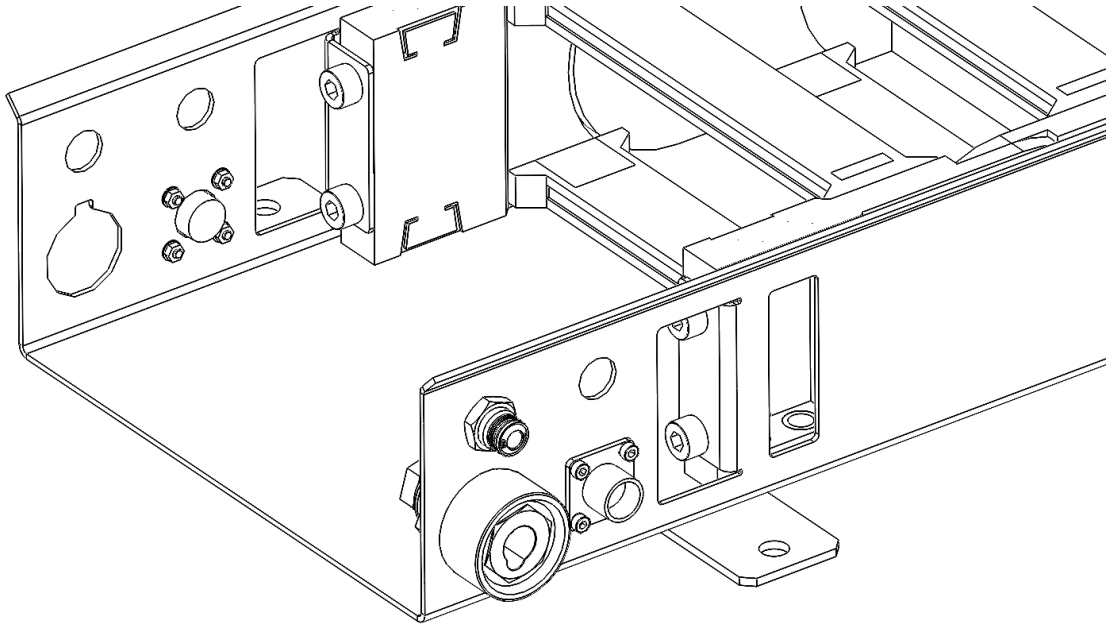

Cleaning station cable colours:

PIN 1 – grey

PIN2 – pink

PIN3 – white

PIN4 – red

PIN5 – yellow

PIN6 – green

PIN7 – brown

PIN8 - blue

5. Assembly and start-up

5.1. Assembly

The TRK500-HD robot track is assembled, connected, and pre-commissioned by the personnel appropriately prepared for this task. These persons are assigned by the manufacturer. These persons have the knowledge and skills required to safely and correctly assemble the machine. Connection to the mains must be carried out in accordance with the Polish Standards. It is not allowed to carry out the assembly independently; this will result in loss of warranty. During the warranty period, the user may not interfere in the electronic or mechanical components except as set forth in this maintenance documentation. Failure to comply with the above will result in loss of warranty.

Linear track must be leveled and fixed to the ground using foundation bolts, M12 bolts with a strength class of at least 10.9 or chemical anchor bolting M12 x 150mm. The spacing of the mounting holes fixing the positioner to the slab is shown in Figure 1. In case of robot with load capacity below 20 kg should be anchored every other mounting hole in the robot base, for robots with a higher load capacity, this should be anchored through each mounting hole.

Concrete class at least c20 - Surface slope up to 5 degrees, Surface irregularities up to 5mm

Detailed installation instructions are described in the instructions:

„K-Track - TRK500-HD Installation Manual“

5.2. Getting ready for operation

After completing the installation work on the linear track:

- Perform all the tasks on connecting the robotic station,

The definition of the external axis is described in the documentation of the External Axis (90210-1292DEC_External_Axis_Addition_Manual_(EOx-Series)).

Detailed configuration instructions are described in the instructions:

„**Configuration - basic settings - K-Tracks**”

„**K-Positioners_cooperation_manual**”

„**External Axis EOx - basic configuration - K-Positioners & K-Tracks**”

5.3. Emergency Stop connection

Safety of the linear axis is ensured by the robot safety circuits and the circuits must be prepared in accordance with Kawasaki Robotics technical documentation.

5.3.1. Cubic-S option

The Cubic-S option can further control the status of the Kawasaki exterior axis. In order for Cubic-S to monitor the linear axis, a value other than "0" should be set in the axis cooperation settings (cooperation enabled, with one of the robot axes).

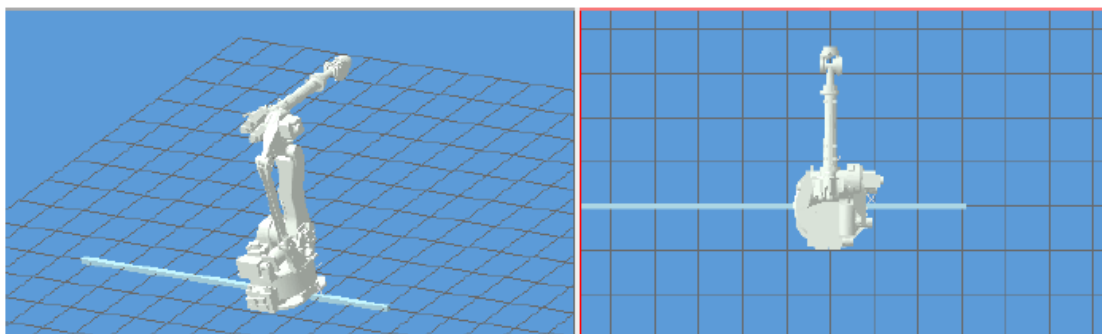

Fig. 3 Stop Monitoring Declaration for auxiliary axis in the Cubic-S option

The definition of the dedicated input for monitoring the status of the auxiliary axis in CUBIC-S is described in **CUBIC-S (90210-1272DEC_Cubic-S_Instruction Manual (E series))**.

5.4. Start-up

To start the linear track, connect it to the robot controller.

Activation of the two-axis positioner is synonymous with the activation of the robotic station and follows the algorithm of the station's operation.

To move the JT7 axis, press the 7 "+" or "-" button on the Teach Pendant with the motors off and DeadMan Switch on.

5.5. Working conditions and safe use.

The TRK500-HD linear track is suitable for indoor use in the following environmental conditions:

- Air free from condensed steam, dust, corrosive or explosive gases,
- Permissible ambient temperature: +5°C ÷ +40°C.

When operating the linear track:

- Observe all the safety rules for safe work at a robotic station;
- Get acquainted with possible health or life hazards due to improper operation of the device;
- An employee handling the robotic station with the TRK500-HD linear track must be familiar with the contents of this Operation and Maintenance Manual and the Operation and Maintenance Manual for the industrial robot;
- It is not permitted to carry out maintenance work during the operation of the station;
- It is forbidden to leave tools on the housing and servo drives.

Detailed health and safety regulations should be developed by the user at the workplace. Observe general health and safety regulations for electrical and mechanical equipment when connecting, starting-up and operating the linear track.

It's not permitted for persons to be present in the operating area of the positioner during the work of the machine (within range of the tilt and working rotation position of the linear track including the tooling) as well as for unauthorized persons to carry out repairs and maintenance.

In addition, the operating crew must know how to attach the tools to the positioner plate and how to place the parts in this equipment.

Secure the robot in the positioner workstation area using fencing and light barriers in accordance with Polish safety standards.

5.6. Maintenance of the K-Track TRK500-HD robot track

Maintenance procedures include measures aiming at reducing wear on parts and components of the mechanical system and ensuring correct robot track operation. Maintenance should be carried out by trained personnel. The service technician authorized to carry out repairs is the manufacturer or a person designated by the manufacturer. The warranty does not cover mechanical damage resulting from improper use of the station.

Before performing any maintenance work, make sure the equipment is disconnected from the mains

5.7. Maintenance schedule

Action	Period of time	
	Daily inspection	5000 hours
Physical damage	<input checked="" type="checkbox"/>	<input checked="" type="checkbox"/>
Gear backlash and abnormal sounds during operation	<input checked="" type="checkbox"/>	<input checked="" type="checkbox"/>
Check the linear track brakes		<input checked="" type="checkbox"/>
Toothed bar greasing		<input checked="" type="checkbox"/>
Check the internal wires		<input checked="" type="checkbox"/>
Battery change		<input checked="" type="checkbox"/>
Linear track carriages greasing		<input checked="" type="checkbox"/>
Checking the tightening torque of the assembly screws *		<input checked="" type="checkbox"/>

* in case of parts replacing

6. Layout of user cables inside the structure

The linear track allows you to carry out the wires through the Igus cable guides.

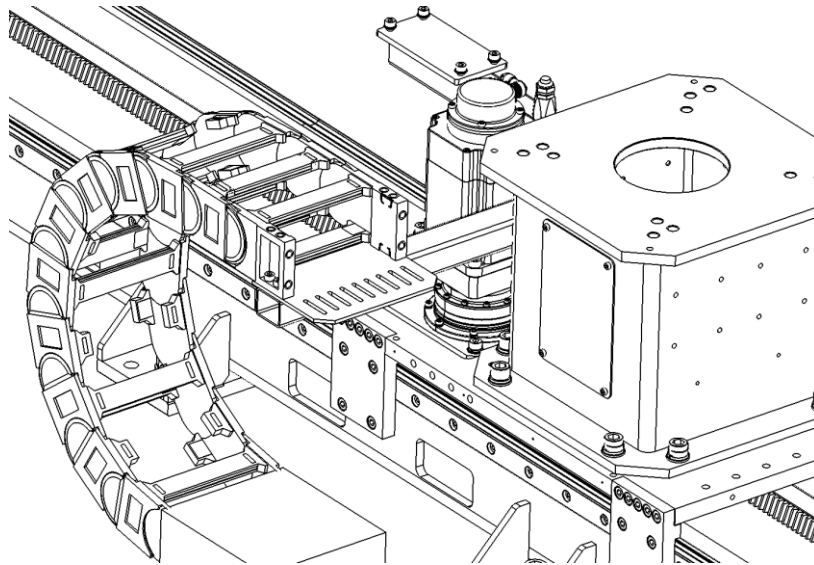

Fig. 4 Cable routing in Igus energy chains

7. Storage and transport conditions

7.1. Storage

The K-Track TRK500-HD robot track should be stored indoors, in rooms free from aggressive corrosive agents. Ambient temperature should range between $+ 5^{\circ} \text{C} \div + 40^{\circ} \text{C}$ and humidity should not exceed 80%. The positioner should also be protected against shocks and vibrations.

7.2. Transport

Transport of the TRK500-HD linear track should be carried out by clean, dry and covered means of transport, protected against penetration of precipitation into the interior and against exceeding the temperatures of +50°C and -25°C. At the same time the positioner must be protected against sliding.

For transporting the TRK500, use the dedicated forklift pockets marked below

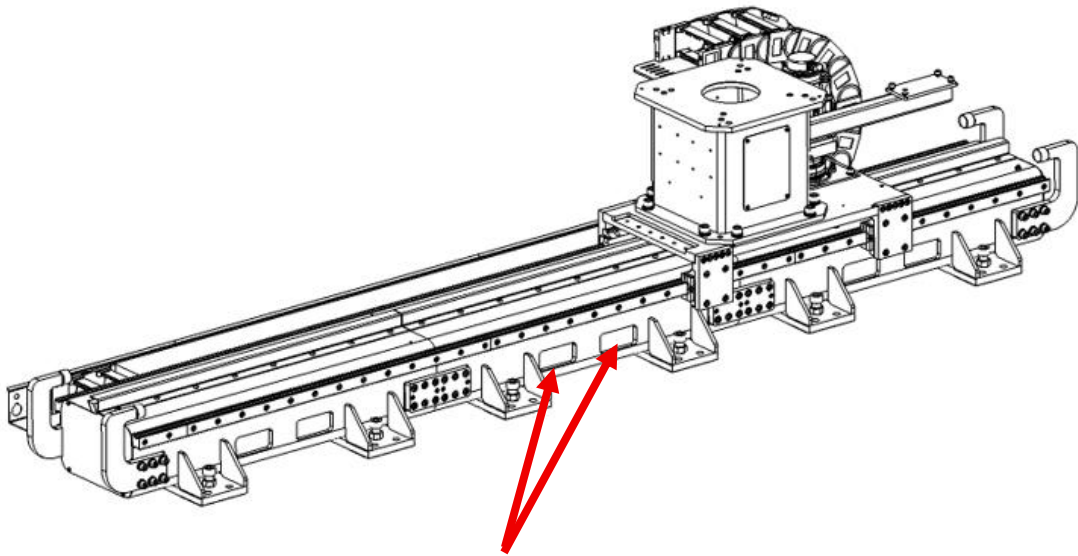

Forklift pockets 160x80mm

8. Safety information and residual risk

The TRK500-HD has been designed and built for precise positioning of objects attached to it in one axis, depending on the used version of the device. It is a prerequisite for the safe use of the device described above that the maximum permissible load shown in this manual is not exceeded.

8.1. Danger due to mechanical construction:

8.1.1. Crashing and cut-offs

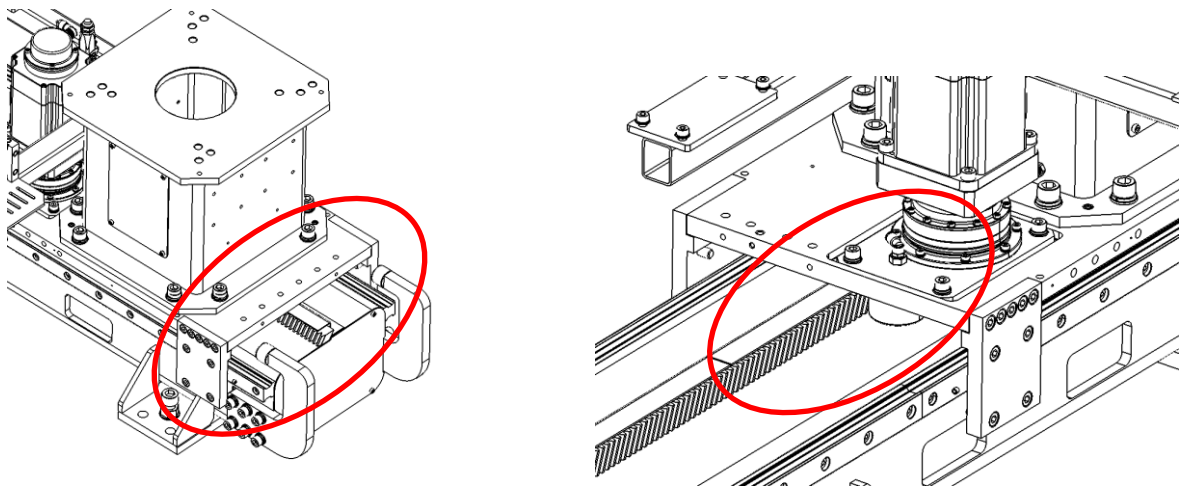

Fig. 5 Areas with the risk of crashing

There is a risk of crashing, cutting fingers or other parts of the body in the marked areas. Do not leave or put any tools or parts of the body or animals in these areas.

It is forbidden to stay in the work zone while the robot track is in operation.

8.2. Dangers due to the electrical system

After connecting the K-Track TRK500-HD robot track to the mains, it is forbidden to connect and/or disconnect the wiring of the device; these actions may result in an electric shock.

8.3. Information about noise emission

The level of the emitted acoustic pressure at the workstations, corrected by the A characteristics, does not exceed the value of 70 dB (A). Peak momentary acoustic pressure at work stations, adjusted by C, does not exceed 63 Pa (130 dB versus 20 μ Pa).

9. Notes

10. Manufacturer's data

ASTOR Sp. z o.o.

29, Smoleńsk St., 31-112 Kraków, Poland

Phone number: +48 (12) 428 63 00

<https://www.astor.com.pl/en>



e-mail: info@astor.com.pl

NIP: 676 01 05 127

Appendix 1. Spare parts list

Parts of the positioner must be ordered from the ASTOR company. List of branches available at: <https://www.astor.com.pl/en/contact-us/>. In order to improve order handling, please specify the positioner model and the part name along with the code.

Spare Parts List:

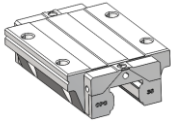
Nazwa	Product code	Quantity [pcs.]
Kawasaki Servo-drive 2kW 	50601-1460	1
Planetary gear 	AD110-010-P0 ADR-110-014-P0*	1
Linear carriage 	HCR35FL	4-6

* depending on the options used

Appendix 2. Standard of cable terminations *

This document describes the ends of cables that are led out from the cable supplied by ASTOR technological solution as well as their lengths protruding beyond the outline of the cable guide.

1. 3-phase power cord

The cable is terminated with a 3P+N+Z 32A-6H IP44

Illustrative photo:



Length of cable protruding beyond the track: approximately 0.5m

2. Ground cable

The cable ends with a socket ŁP ŁW 50mm

Illustrative photo:



Length of cable protruding beyond the track: tip is attached to the panel at the end of the cable guide.

3. Pneumatic pipe

Pneumatic pipe (8mm) is terminated with a type 26 male quick connector

Illustrative photo:



Length of cable protruding beyond the track: tip is attached to the panel at the end of the cable guide.

There is an additional pneumatic outlet on the panel for service use, terminated a type 26 female quick connector.

Illustrative photo:



4. Gas cable

The 8mm reinforced gas pipe is terminated with a type 26 male quick connector
Illustrative photo:



Length of cable protruding beyond the track: approximately 0.5 m

5. Ethernet cable (2 pieces)

The cable is terminated with an RJ45 female socket
Illustrative photo:



Length of cable protruding beyond the track: tip is attached to the panel at the end of the cable guide.

6. Signal cable of the cleaning station

The cable is terminated with a 9-pin male plug, supplied with a matching female plug for self-assembly (soldering).

Illustrative photo:

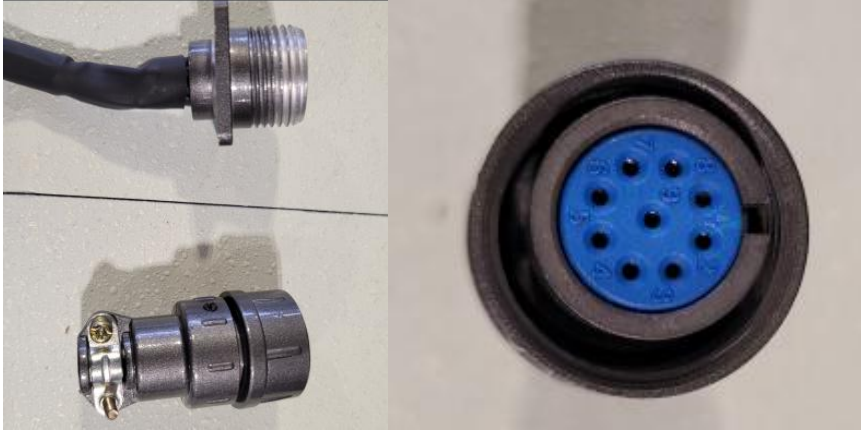

Length of cable protruding beyond the track: tip is attached to the panel at the end of the cable guide.

7. Robot-controller cables

Cables used to connect the manipulator to the controller terminated with appropriate plugs

Illustrative photo:

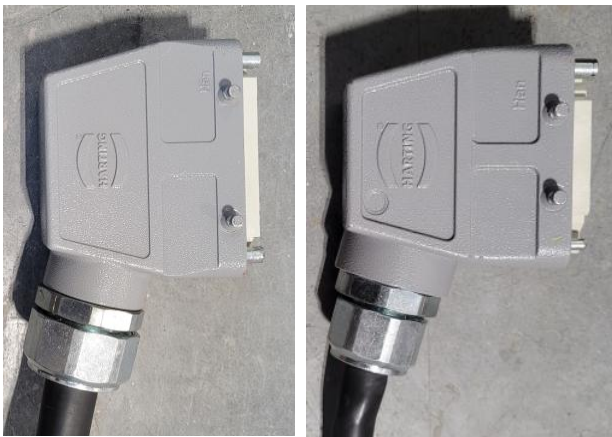

Length of cable protruding beyond the track: length depends on the technological solution used.

*specific cable on request

8. Connection panel

The panel shown below is an illustrative photo of the delivered solution, which is located at the end of the robot track cable guide.



