

# **K**-Positioner

## PST125-F2

**Double axis welding positioner with rated capacity of 125 kg**

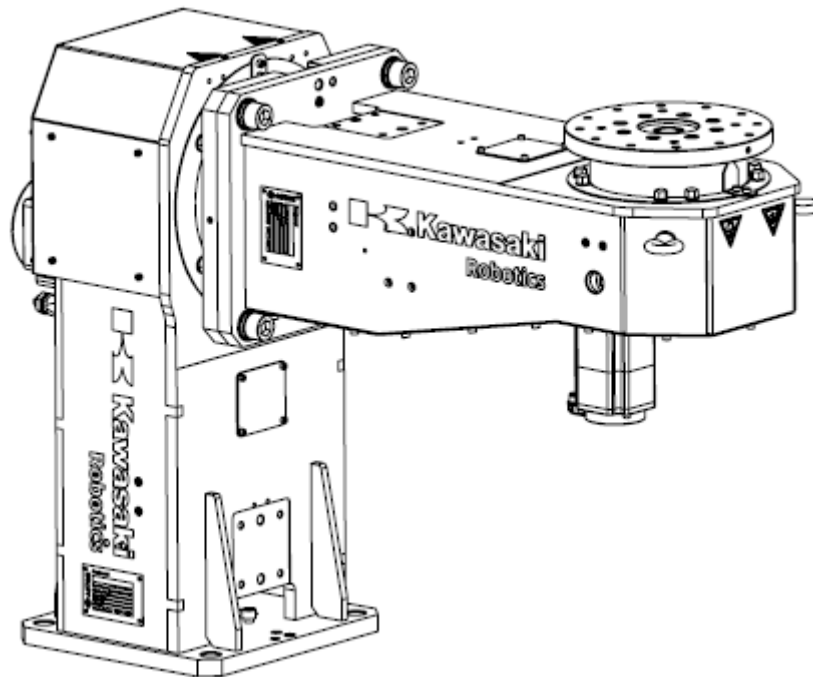

**Contents:**

- 1. Introduction ..... 2
- 2. Technical parameters..... 3
- 3. External dimensions ..... 4
- 4. Markings on the machine..... 5
- 5. Load charts ..... 7
  - 5.1. Maximum rated load distances..... 7
  - 5.2. Chart of the load relative from the distance from the plate axis ..... 7
  - 5.3. Chart of the load relative from the distance from the plate ..... 8
- 6. Basic units of the welding positioner..... 8
  - 6.1. Mechanical system..... 8
  - 6.2. Electrical system..... 9
- 7. Assembly and start-up ..... 9
  - 7.1. Assembly ..... 9
  - 7.2. Getting ready for operation ..... 11
  - 7.3. Emergency Stop connection..... 12
    - 7.3.1. Cubic-S Option..... 12
  - 7.4. Start-up ..... 13
  - 7.5. Working and safe use conditions ..... 14
  - 7.6. Maintenance of the positioner ..... 15
  - 7.7. Maitenance schedule ..... 15
  - 7.8. Supplementation of the copper paste in the ground transfer system.... 16
  - 7.9. Adjustment of the clamping force of the ground transferring system ... 16
- 8. Lay of user cables inside the structure ..... 17
- 9. Storage and transport conditions ..... 18
  - 9.1. Storage..... 18
  - 9.2. Transport ..... 18
- 10. Safety information and residual risk ..... 19
  - 10.1. Danger due to mechanical construction: ..... 19
    - 10.1.1. Crashing and cut-offs..... 19
  - 10.2. Dangers due to the electrical system ..... 19
- 11. Warranty conditions..... 19
- 12. Notes ..... 20
- 13. Manufacturer’s data ..... 23

Appendix 1 - Spare parts list

## 1. Introduction

Two-axis (rotary-tilting) PST125-F2 welding positioner is an electrically driven positioner. It is equipped with rotary axes controlled in a continuous manner. It is designed to work in a robotic welding station and is used to rotate and tilt the welded parts. **It is controlled from the Kawasaki robot controller as additional axes.** Read and understand this manual thoroughly, and take appropriate safety measures in using this product.

All units are displayed in metric system.

- 
- I. These instructions do not constitute a guarantee of the system in which the welding positioner is installed. Accordingly, the ASTOR company is not liable for any accidents, damages and/or problems related to industrial property rights arising as a result of using the system.
  - II. It is recommended that all personnel assigned to operating, teaching, servicing or maintaining the welding positioner attend the necessary courses when installing the system before commencing the performance of their duties.
  - III. The ASTOR company reserves the right to alter, correct or update this manual without prior notice.
  - IV. Keep the following instructions with care and in a place where they can always be available for use. If the welding positioner is re-installed or relocated, please attach these complete and unaltered instructions. In case the instructions are lost or damaged, please contact the ASTOR company.
-

## 2. Technical parameters of PST125-F2 welding positioner

Parameter	PST125-F2
Max. Payload	125 kg
Nominal Torque JT1	490 Nm
Max. Torque JT1	1200 Nm
Nominal Torque JT2	265 Nm
Max. Torque JT2	660 Nm
Turning Range JT1	+/-180°
Turning Range JT2	+/-360°*
Max. Rotating Speed JT1	150°/s
Max. Rotating Speed JT2	180°/s
Repeatability	±0.05 mm*
Max. Offset COG from Rotating Axis JT2	140 mm
Max. Offset COG from Flange Surface	200 mm
Max. Mass moment of inertia JT1	182 kgm <sup>2</sup>
Max. Mass moment of inertia JT2	80 kgm <sup>2</sup>
Mass	214 kg
Default Height of Rotating Axis JT1	709 mm
Installation Position	Floor
Nominal weld current – 100% duty cycle	500 A
Environment conditions	0-40°C
Emitted acoustic pressure (adjusted by A)	< 70 dB
Emitted acoustic pressure (adjusted by C)	< 63 Pa

\*R=340mm from rotating axis

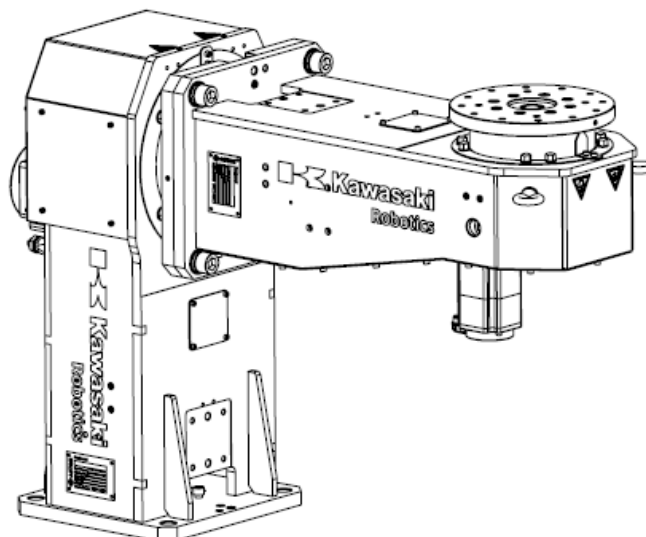

### 3. External dimensions

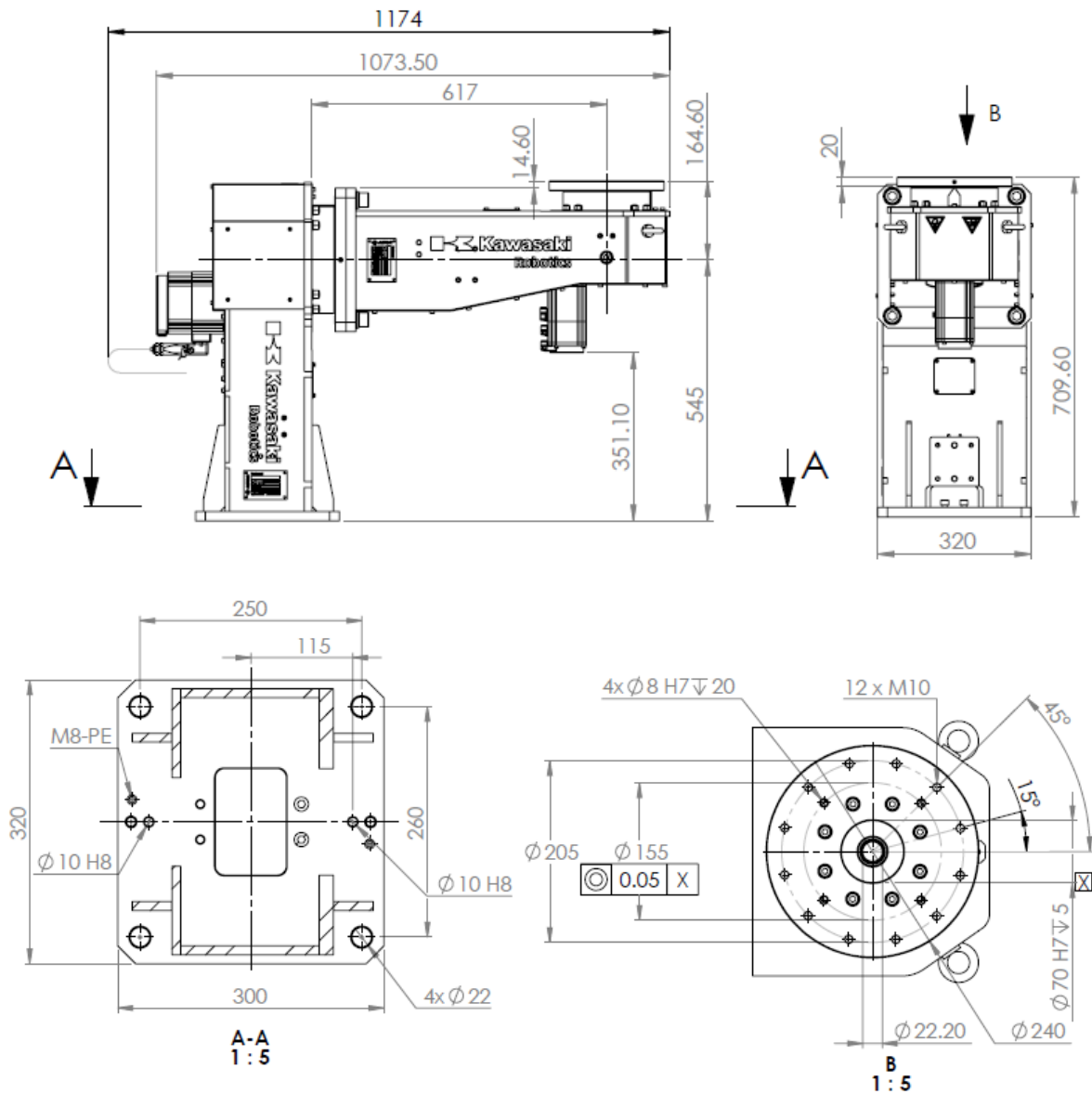

Fig. 1 Basic dimensions of the welding positioner with spacing of fixing holes on the base and the plate

### 4. Markings on the machine



High voltage warning label



Rotating machine parts warning label



Compression/crashing warning label



Hot surface warning label



Information label



#### UWAGA! CAUTION!

Przed instalacją, włączeniem, serwisem lub rozmontowaniem zapoznaj się dokumentacją techniczną urządzenia

Before installation, start-up, maintenance or dissembling read and follow the safety directions and operating instructions!

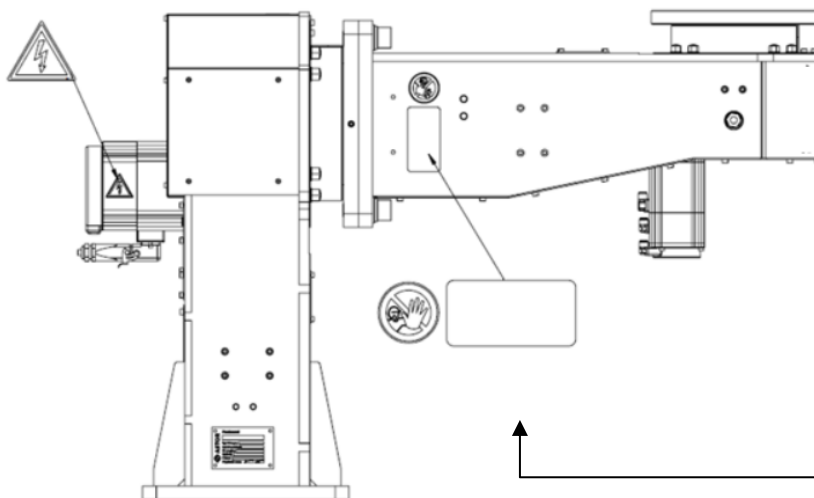
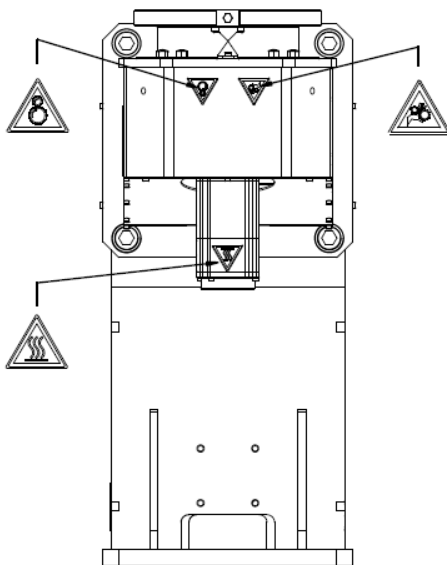

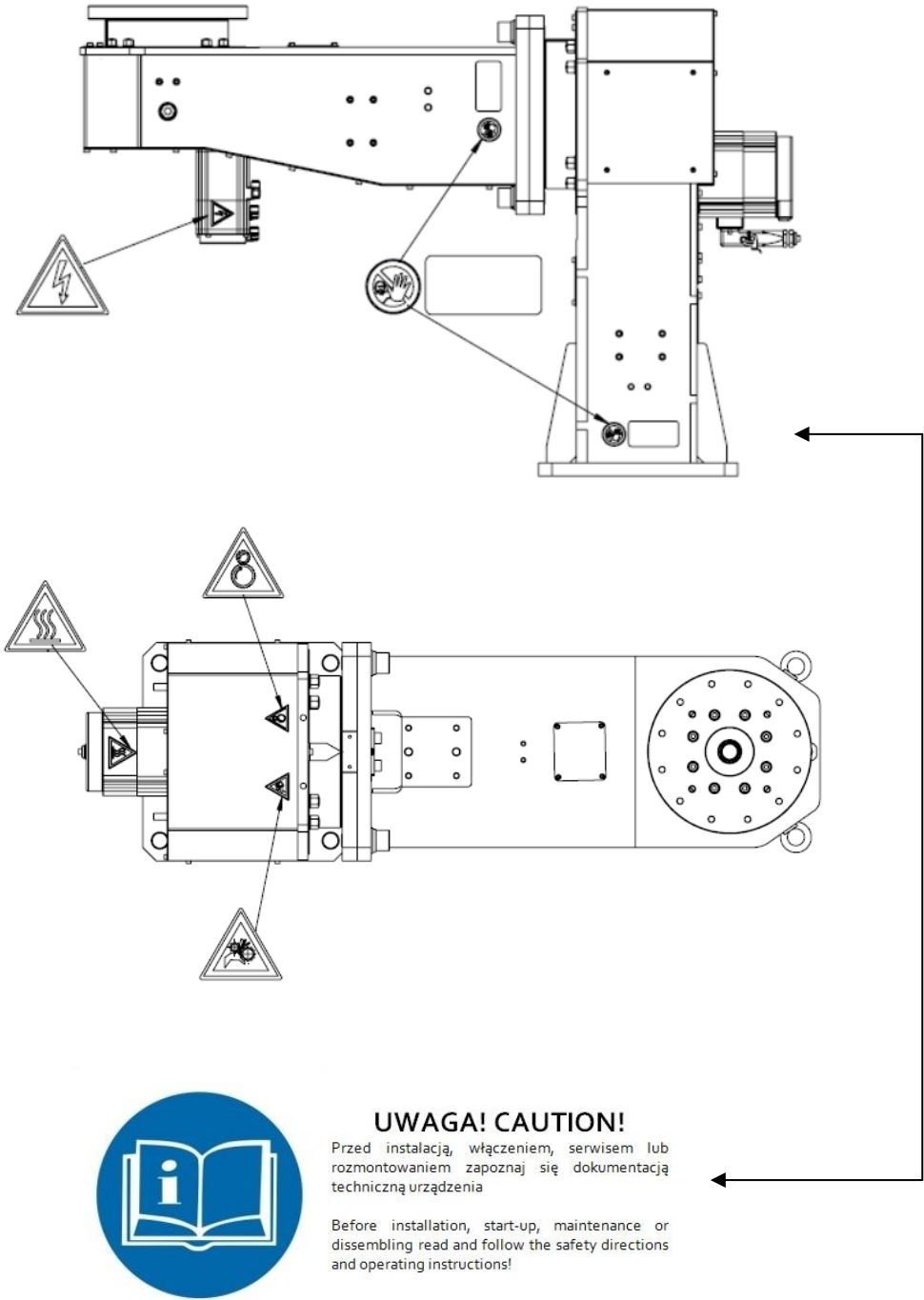

Fig. 2 Warning signs located on the welding positioner

## 5. Load charts

### a. Maximum rated load distances

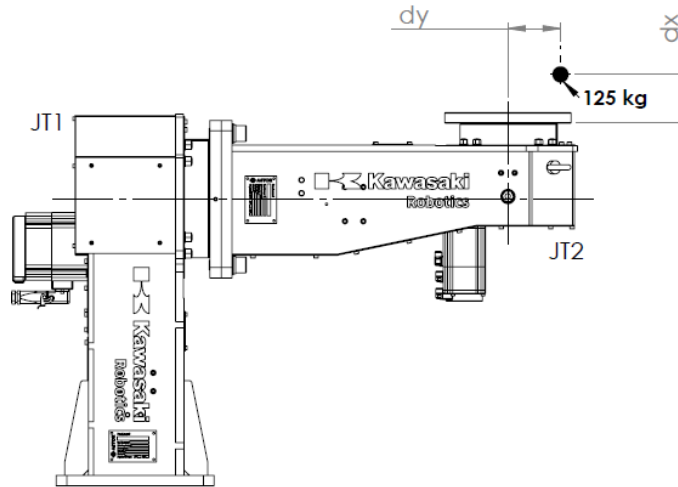

Fig. 3 Nominal rated load position

### b. Chart of the load relative from the distance from the plate axis

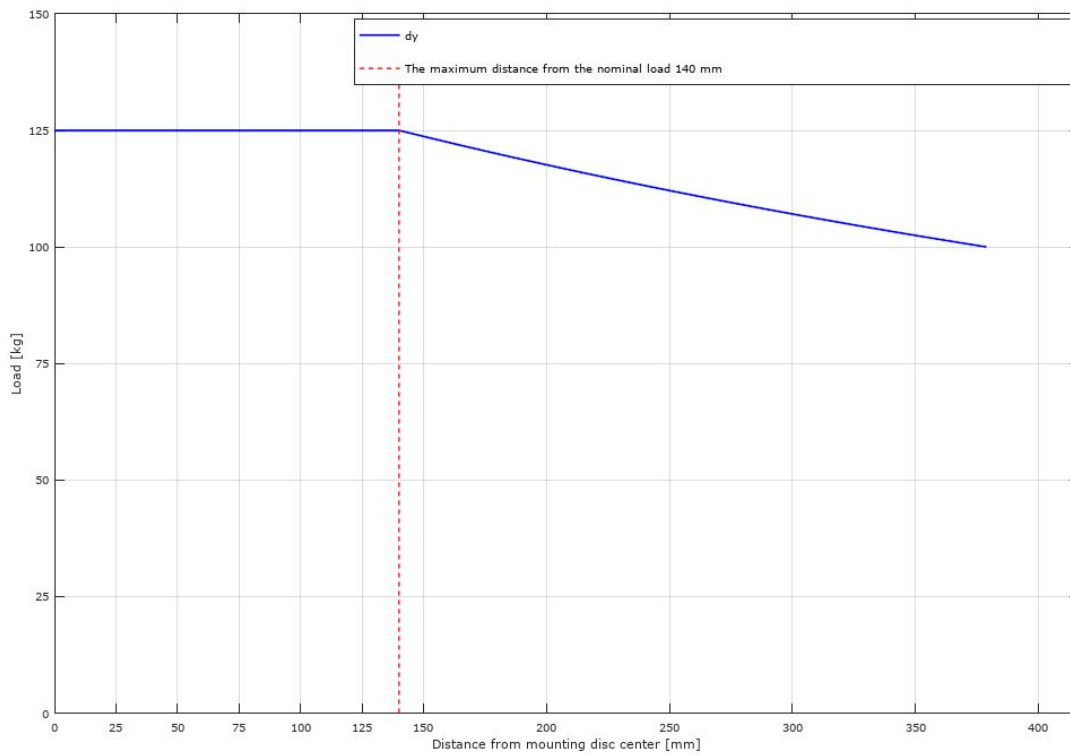

Fig. 4 Drive torque of the axis

**c. Chart of the load relative from the distance from the plate**

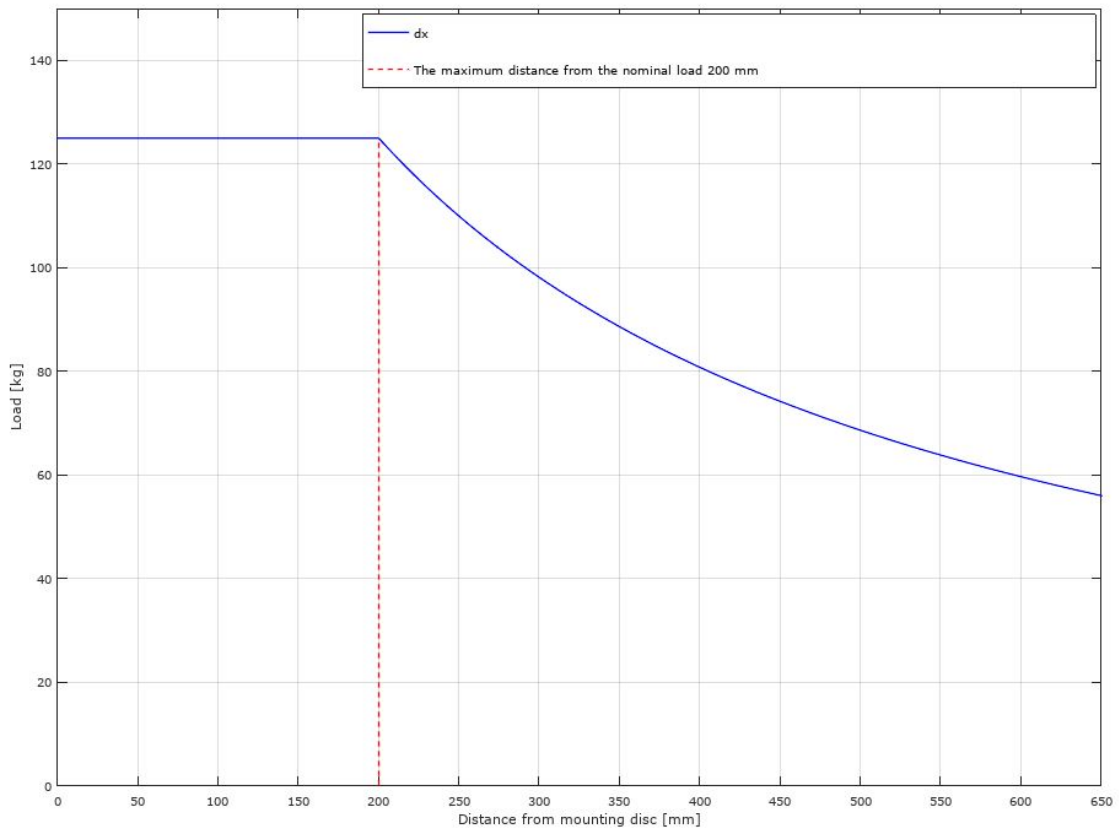
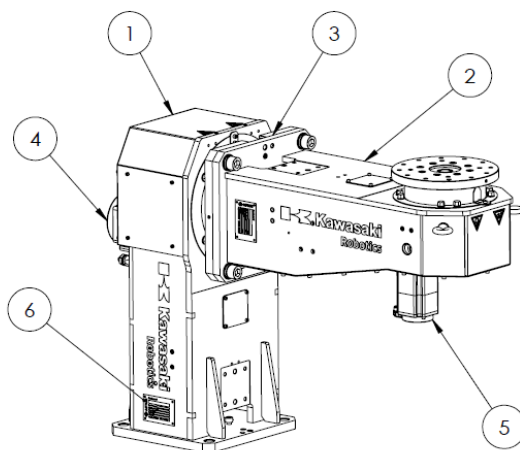

Fig. 5 Rigidity of the structure

**6. Basic units of the welding positioner**

**a. Mechanical system**



1. Basic module – PST250,
2. Basic module – PST125,
3. Mounting plate - connecting two modules into one device,
4. Kawasaki Servo 1.2 kW,
5. Kawasaki Servo 0.675 kW,
6. Rating plate

Fig.6 Basic units of the welding positioner

## b. Electrical system

The power units consists of:

**Axis 1** (plate tilt in the range of  $-180^{\circ} \div 180^{\circ}$ ) Kawasaki servo motor 1.2 kW and cycloidal transmission.

**Axis 2** (rotation of the plate  $-360^{\circ} \div 360^{\circ}$ ) Kawasaki servo motor 0.675kW and cycloidal transmission.

The axes are controlled as external axes from the robot control system. It is not possible to move the welding positioner without connecting it to the KAWASAKI robot controller.

Standard length of electrical wires connecting the servo with the controller is 15 m, but usable length is 13m.

The ground is transferred to the rotating plate by means of a set of 2 copper blocks located below the bottom of the welding positioner gear.

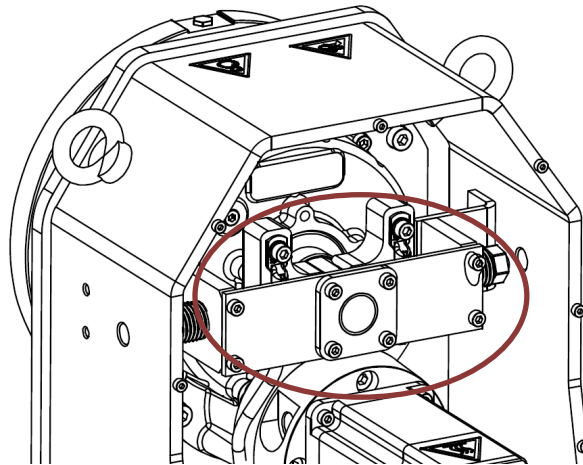

Fig. 7 Ground transfer of the PST125-F2 welding positioner

## 7. Assembly and start-up

### a. Assembly

The PST125-F2 is assembled, connected, and pre-commissioned by the personnel appropriately prepared for this task. These persons are assigned by the manufacturer. These persons have the knowledge and skills required to safely and correctly assemble the machine. Connection to the mains must be carried out in accordance with the Polish Standards. It is not allowed to carry out the assembly independently; this will result in loss of warranty. During the warranty period, the user may not interfere in the electronic or mechanical components except as set forth in this maintenance documentation. Failure to comply with the above will result in loss of warranty.

The welding positioner must be leveled and fixed to the ground using foundation bolts, M20 bolts with a strength class of at least 10.9 or M20 x 260

chemical anchor bolting. The spacing of the mounting holes fixing the welding positioner to the slab is shown in Figure 1.

The positioning connector is used to properly install the welding positioner on the station, after fastening the welding positioner to the ground, the connector can be unscrewed.

In this case, place a steel slab of the thickness of at least 28 mm (thread length min. 25 mm); the slab size and the concrete class must withstand the transfer of the torque values given below.

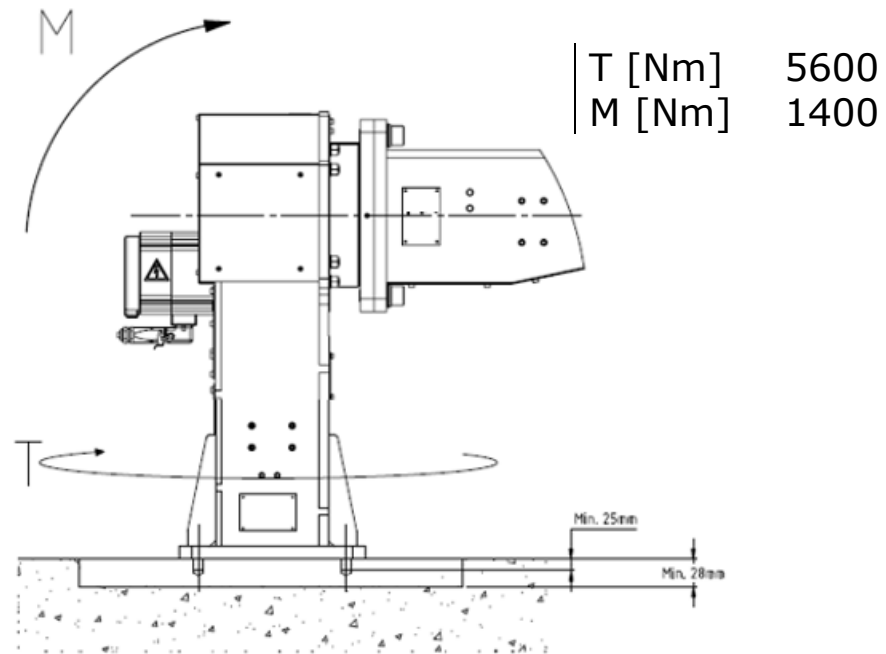

Fig. 8 Mounting the welding positioner directly on the floor - fixed slab

The second case assumes mounting the welding positioner on a steel slab anchored to the concrete with 6xM20 chemical anchor bolting. Spacing of the anchor holes for concrete – PCD650

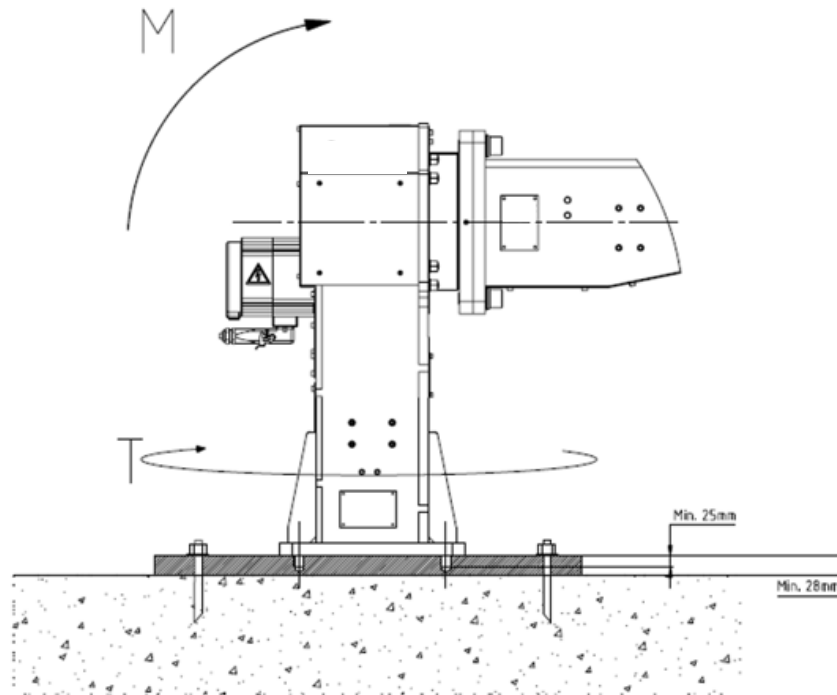

Fig. 9 Mounting the welding positioner directly on the floor - anchored slab

### **b. Getting ready for operation**

After completing the installation work on the welding positioner:

- Perform all the tasks on connecting the robotic station;

- Set up the tool for the welding positioner;
- Place the part in the tool.

**The definition of the external axis is described in the documentation of the External Axis (90210-1292DEC\_External\_Axis\_Addition\_Manual\_(EOx-Series)).**

**c. Emergency Stop connection**

Safety of the JT1 and JT2 axes is ensured by the robot safety circuits and the circuits must be prepared in accordance with Kawasaki technical documentation.

For proper safety of the JT1 and JT2 axes of the welding positioner, two PN\_CMD and PN\_ON signals must be connected to the robot inputs, the signals come from the safety curtain or the safety controller. The signals in a high state after the axes control group (GROUP) change, cause power cut to the servo which is located close to the operator.

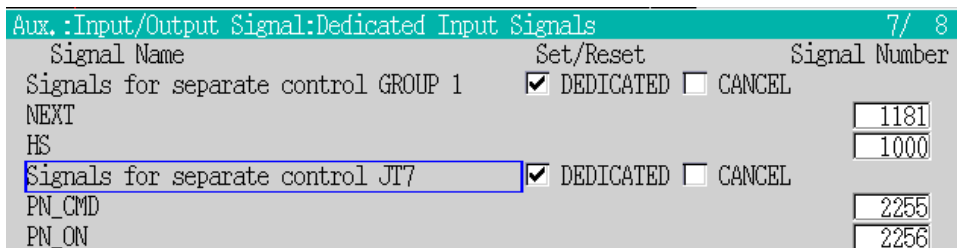

Fig. 10 Auxiliary axis off signal declaration

**CAUTION!**

When the positioner is supplied, the PN\_CMD and PN\_ON signals are declared as internal signals. This should be changed when the positioner is integrated in the position.

**i. Cubic-S Option**

The Cubic-S option can further control the status of the Kawasaki exterior axis. In order to add the axis monitoring, declare axis 7, 8 or 9 as DEVICE 1, 2 or 3.

No.	Classification	Name	Unit	Value1	Value2	Value3	Value4	Value5	Value6	Value7	Value8	Value9
601	Stop Monitoring	Valid/Invalid in Teach Mode/Fast-forward Check	-	Valid								
32		Robot Joint Definition (1-9)	-	0	0	0	0	0	0	0	0	0
38		Device 1 Joint Definition (1-9)	-	0	0	0	0	0	0	0	0	0
39		Device 2 Joint Definition (1-9)	-	0	0	0	0	0	0	0	0	0
40		Device 3 Joint Definition (1-9)	-	0	0	0	0	0	0	0	0	0

Fig. 11 Stop Monitoring Declaration for auxiliary axis in the Cubic-S option

The definition of the dedicated input for monitoring the status of the auxiliary axis in CUBIC-S is described in **the documentation of the CUBIC-S option (90210-1272DED\_Cubic-S\_Instruction Manual (E series))**.

#### d. Start-up

To start the welding positioner, connect it to the robot control system.

Connect the 50979-0073L15 with the B marking to the B-JT8 MOTOR in the Kawasaki controller

Connect the 50979-3340L13 with the B marking to the B-JT8 SIGNAL in the Kawasaki controller

Connect the 50979-0073L15 with the C marking to the C-JT8 MOTOR in the Kawasaki controller

Connect the 50979-3340L13 with the C marking to the C-JT8 MOTOR in the Kawasaki controller

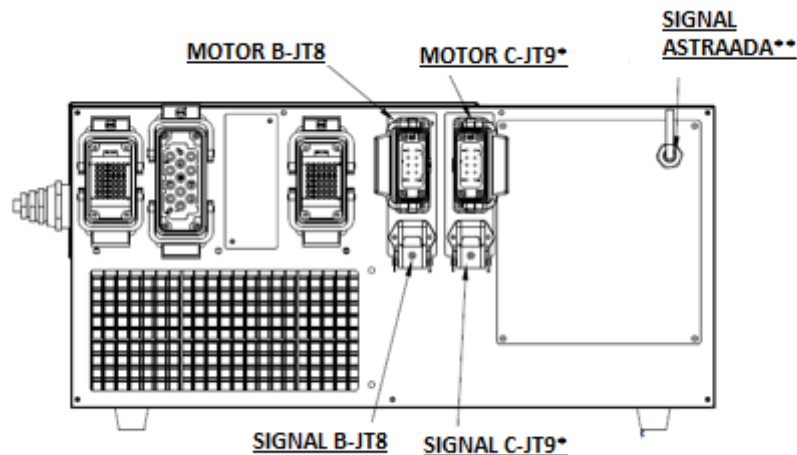

\* - connecting the second auxiliary axis wires - a station with two auxiliary Kawasaki axes,

\*\*-only when controlling additional indexing servomotors.

Starting up the biaxial welding positioner starts up the robotic station and follows the positioning algorithm.

To move the axis JT7 or JT8 (drives Kawasaki), you should choose the appropriate group. Press the "ALT" key on the Teach Pendant off Monitors under (C) of the screen TP.JT7 or JT8.

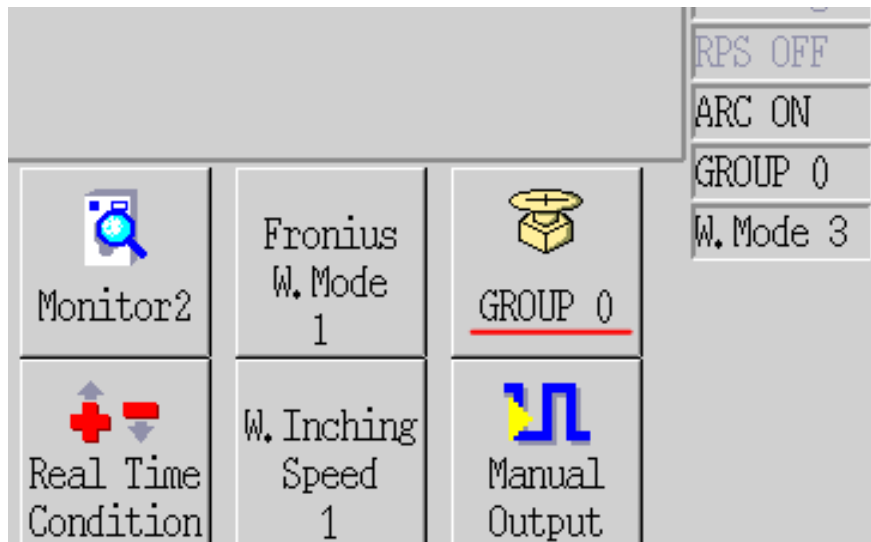

**GROUP -1** - no possibility of moving additional axes,

**GROUP 0** - the ability to move axes without cooperation,

**GROUP 1** - moving the JT7 and JT8 axis in co-operative mode.

Fig. 12 Revision Steering Group axes

Starting the welding positioner is synonymous with starting the robotic station and follows the algorithm of the station's operation.

### e. Working and safe use conditions

The PST125-F2 welding positioner is suitable for indoor use in the following environmental conditions:

- Air free from condensed steam, dust, corrosive or explosive gases;
- Permissible ambient temperature: +5°C ÷ +40°C;
- Maximum temperature of the welding positioner's plate: 90°C.

When operating the welding positioner:

- Observe all the safety rules for safe work at a robotic station;
- Get acquainted with possible health or life hazards due to improper operation of the device;
- An employee handling the robotic station with the PST125-F2 welding positioner must be familiar with the contents of this Operation and Maintenance Manual and the Operation and Maintenance Manual for the industrial robot;
- It is not permitted to carry out maintenance work during the operation of the station
- It is forbidden to leave tools on the housing and servo drives of the welding positioner.

Detailed health and safety regulations should be developed by the user at the workplace. Observe general health and safety regulations for electrical and mechanical equipment when connecting, starting-up and operating the welding positioner.

It is not permitted for persons to be present in the operating area of the welding positioner during the work of the machine (within range of the tilt and working rotation position of the welding positioner including the tooling) as well as for unauthorized persons to carry out repairs and maintenance.

In addition, the operating crew must know how to attach the tools to the welding positioner plate and how to place the parts in this equipment.

Secure the robot in the welding positioner workstation area using fencing and light barriers in accordance with Polish safety standards.

**f. Maintenance of the welding positioner**

Maintenance procedures include measures aiming at reducing wear on parts and components of the mechanical system and ensuring correct welding positioner operation. Maintenance should be carried out by trained personnel. The service technician authorized to carry out repairs is the manufacturer or a person designated by the manufacturer. The warranty does not cover mechanical damage resulting from improper use of the station.

**Before performing any maintenance work, make sure the equipment is disconnected from the mains**

**g. Maintenance schedule**

Action \ Period of time	Daily inspection	Monthly inspection	2500 hours	5000 hours or 1 year
Physical damage	<input checked="" type="checkbox"/>		<input checked="" type="checkbox"/>	
Gear backlash and abnormal sounds during operation	<input checked="" type="checkbox"/>		<input checked="" type="checkbox"/>	
* Complement to the copper paste on the shaft of the disc in the ground transfer system		<input checked="" type="checkbox"/>	<input checked="" type="checkbox"/>	
Replenish gear lubrication and bearings				
Check the positioner brakes			<input checked="" type="checkbox"/>	
Refresh transmission lubricants			<input checked="" type="checkbox"/>	
Check the internal wires of the positioner			<input checked="" type="checkbox"/>	
Battery change			<input checked="" type="checkbox"/>	
Check the welding mass clamps			<input checked="" type="checkbox"/>	
** Replacement of welding mass clamps			<input checked="" type="checkbox"/>	
Checking the tightening torque of the assembly screws			<input checked="" type="checkbox"/>	
Technical review made by authorized service K-Positioners				<input checked="" type="checkbox"/>

\* instruction on performing the activity in item 7.8

\*\* In case of excessive wear and tear

**h. Supplementation of the copper paste in the ground transfer system**

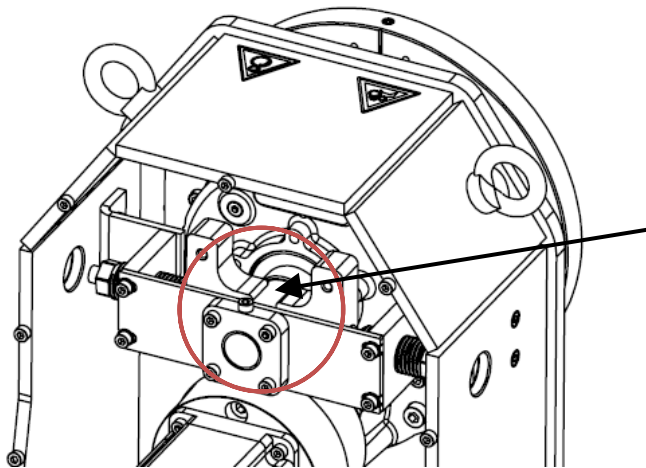

On the shaft of the disk, the copper paste in the ground transfer system should be supplemented

Fig. 13 Place of restoration of copper paste

The recommended measure is the grease or copper paste (WÜRTH CU 800), which as a means of separating, protects the surface against seizing. In order to be completed, you must remove the back cover of keeping any precautions-the device must be disconnected from the power supply. Then clean the old grease length and apply a new one. The action should be performed once a month.

**i. Adjustment of the clamping force of the ground transferring system**

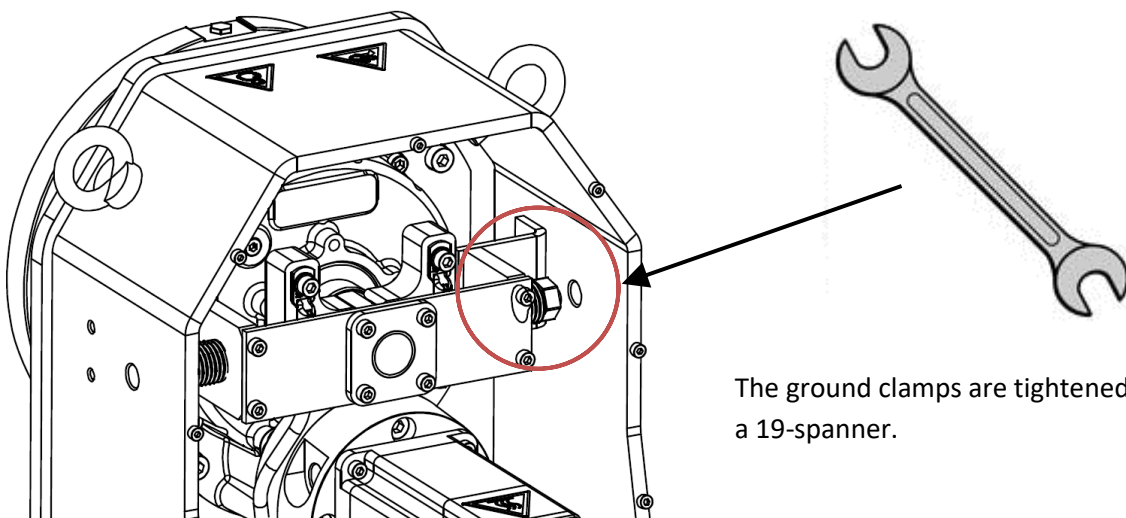

The ground clamps are tightened with a 19-spanner.

Fig. 14 Tightening place of the ground clamps

## 8. Layout of user cables inside the structure

The base module allows laying the user wires through the open gear and the body of the device itself. The diameter of the passage opening is 22 mm. The flight of the first axis with a diameter of 36 mm is half occupied by the wires of the second axis of the welding positioner.

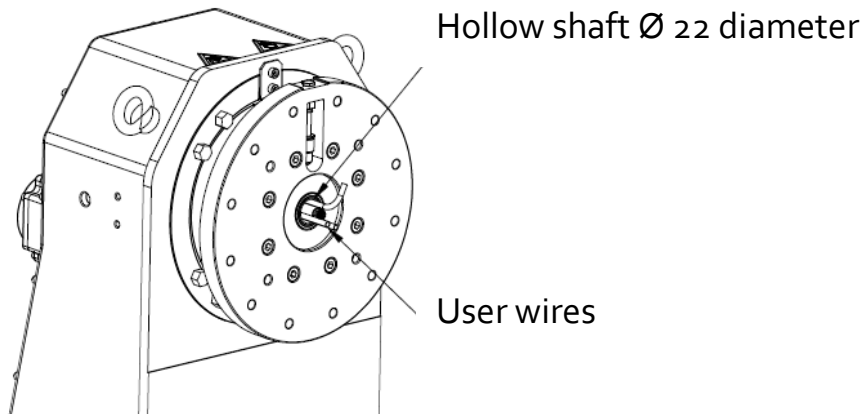

Fig. 15 Layout of wires inside the structure

## 9. Storage and transport conditions

### a. Storage

The PST125-F2 biaxial welding positioner should be stored indoors, in rooms free from aggressive corrosive agents. Ambient temperature should range between + 5 ° C ÷ + 40 ° C and humidity should not exceed 80%. The welding positioner should also be protected against shocks and vibrations.

### b. Transport

Transport of the welding positioner should be carried out by clean, dry and covered means of transport, protected against penetration of precipitation into the interior and against exceeding the temperatures of + 50°C and - 25°C. At the same time the welding positioner must be protected against sliding.

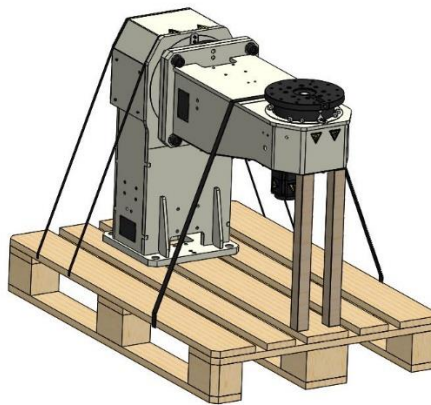

Fig. 16 The way of transporting the welding positioner on a Euro pallet

## 10. Safety information and residual risk

The PST125-F2 has been designed and built for precise positioning of objects attached to it in two axes, depending on the used version of the device. It is a prerequisite for the safe use of the device described above that the maximum permissible load shown in this manual is not exceeded.

### a. Danger due to mechanical construction:

#### i. Crashing and cut-offs

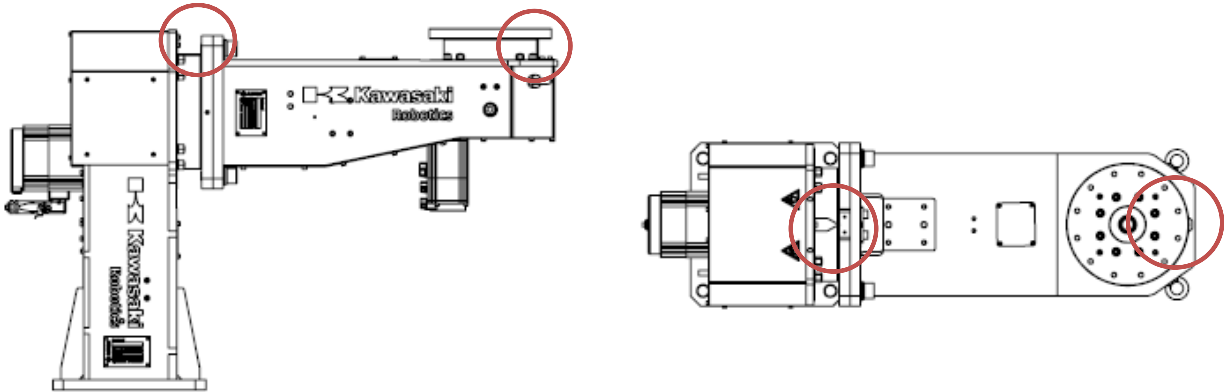

Fig. 17 Areas with the risk of crashing

There is a risk of crashing, cutting fingers or other parts of the body in the marked areas. Do not leave or put any tools or parts of the body or animals in these areas.

**It is forbidden to stay in the work zone while the welding positioner is in operation.**

### b. Dangers due to the electrical system

After connecting the welding positioner to the mains, it is forbidden to connect and/or disconnect the wiring of the device; these actions may result in an electric shock.

## 11. Warranty conditions

Warranty covers only defects arising from causes inherent in the sold product. The manufacturer's warranty covers 12 months. The basic principle of the maintenance of warranty is to use a table with the timing of the steps preservatives (p. 15) and use the device as intended and technical parameters.

**12. Notes**

**Appendix 1.**

Parts of the welding positioner must be ordered from the ASTOR company. Contact data available at: [www.astor.com.pl/en/contact-us/](http://www.astor.com.pl/en/contact-us/). In order to improve order handling, please specify the welding positioner model and the part name along with the code.

Spare Parts List:

Name		Product code	Quantity [pcs.]
<b>Kawasaki Servo drive 0.675kW</b>		50601-1461	1
<b>Kawasaki Servo drive 1.2kW</b>		50601-1465	1
<b>JT2 Cycloidal transmission</b>		PST-RDS-027C	1
<b>JT1 Cycloidal transmission</b>		PST-RDS-050C	1
<b>Ground transfer</b>		PST125-MASA	1
<b>JT2 Body</b>		PST125-BODY	1

<b>JT2 Plate</b>		PST125-PLATE	1
<b>JT1 Body</b>		PST250-BODY	1
<b>F2 Mounting</b>		PST-F2	1

### **13. Manufacturer's data**



**ASTOR Sp. z o.o.**

**29, Smoleńsk St., 31-112 Kraków, Poland**

**Phone number: +48 (12) 428 63 00**

**<https://www.astor.com.pl/en>**

**e-mail: [info@astor.com.pl](mailto:info@astor.com.pl)**

**NIP: 676 01 05 127**



