

K-Positioner

PST230SE

**Single axis welding positioner drive module
with rated capacity of 230 kg**

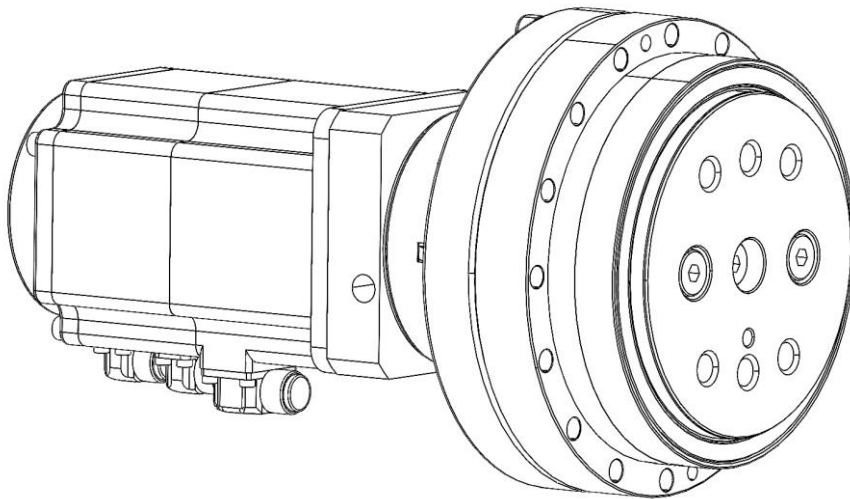

Contents:

- 1. Introduction 2
- 2. Technical parameters of PST230SE welding positioner drive module 3
- 3. External dimensions 4
- 4. Markings on the machine 6
- 5. Load charts..... 7
 - 5.1. Maximum rated load distances 7
 - 5.2. Chart of the load relative from the distance from the plate axis 7
- 6. Basic units of the welding positioner drive module..... 8
 - 6.1. Mechanical system..... 8
 - 6.2. Electrical system..... 8
- 7. Assembly and start-up 9
 - 7.1. Assembly 9
 - 7.2. Getting ready for operation..... 9
 - 7.3. Emergency Stop connection..... 9
 - 7.3.1. Cubic-S Option..... 10
 - 7.4. Start-up..... 10
 - 7.5. Working and safe use conditions 12
 - 7.6. Maintenance of the welding positioner drive module..... 12
 - 7.7. Maintenance schedule 13
- 8. Storage and transport conditions..... 13
 - 8.1. Storage..... 13
 - 8.2. Transport..... 13
- 9. Safety information and residual risk 14
 - 9.1. Danger due to mechanical construction: 14
 - 9.1.1. Crashing and cut-offs..... 14
 - 9.2. Dangers due to the electrical system..... 14
- 10. Warranty conditions..... 14
- 11. Notes 15
- 12. Manufacturer’s data 17

Appendix 1 - Spare parts list

1. Introduction

One-axis (tilting) PST230SE welding positioner drive module drive module is an electrically driven positioner. It is equipped with rotary axes controlled in a continuous manner. It is designed to work in a robotic welding station and is used to rotate and tilt the welded parts. **It is controlled from the Kawasaki Robotics robot controller as additional axis.** Read and understand this manual thoroughly, and take appropriate safety measures in using this product.

All units are displayed in metric system.

-
- I. These instructions do not constitute a guarantee of the system in which the positioner is installed. Accordingly, ASTOR company is not liable for any accidents, damages and/or problems related to industrial property rights arising as a result of using the system.
 - II. It is recommended that all personnel assigned to operating, teaching, servicing or maintaining the welding positioner drive module attend the necessary courses when installing the system before commencing the performance of their duties.
 - III. ASTOR company reserves the right to alter, correct or update this manual without prior notice.
 - IV. Keep the following instructions with care and in a place where they can always be available for use. If the welding positioner drive module is re-installed or relocated, please attach these complete and unaltered instructions. In case the instructions are lost or damaged, please contact the Astor company.
-

2. Technical parameters of PST230SE welding positioner drive module

Parameter	PST230SE
Max. Payload	230 kg
Nominal Torque	167 Nm
Max. Torque	412 Nm
Max. Tilting Torque	882 Nm
Turning Range	+/-360°*
Max. Rotating Speed	120°/s
Repeatability	±0.05 mm**
Max. Offset COG from Rotating Axis JT1	102 mm
Max. Mass moment of inertia	27.31 kgm ²
Mass	8 kg
Installation Position	Any
Environment cond.	0-40°C
Emitted acoustic pressure (adjusted by A)	< 70 dB
Emitted acoustic pressure (adjusted by C)	< 63 Pa

*possibility of setup range +/-36000

**on radius r=340mm from rotating axis

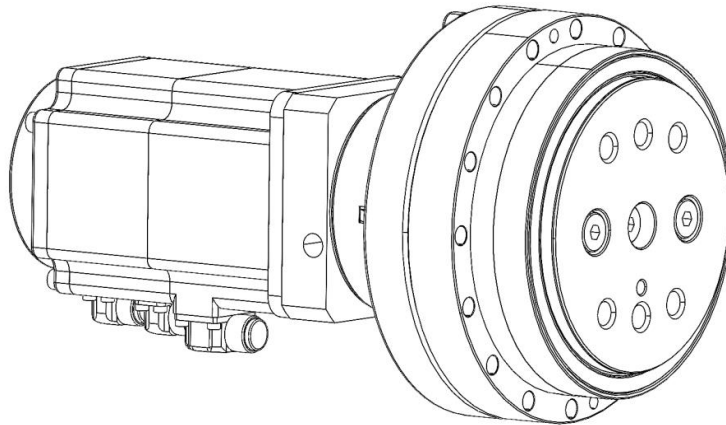

3. External dimensions

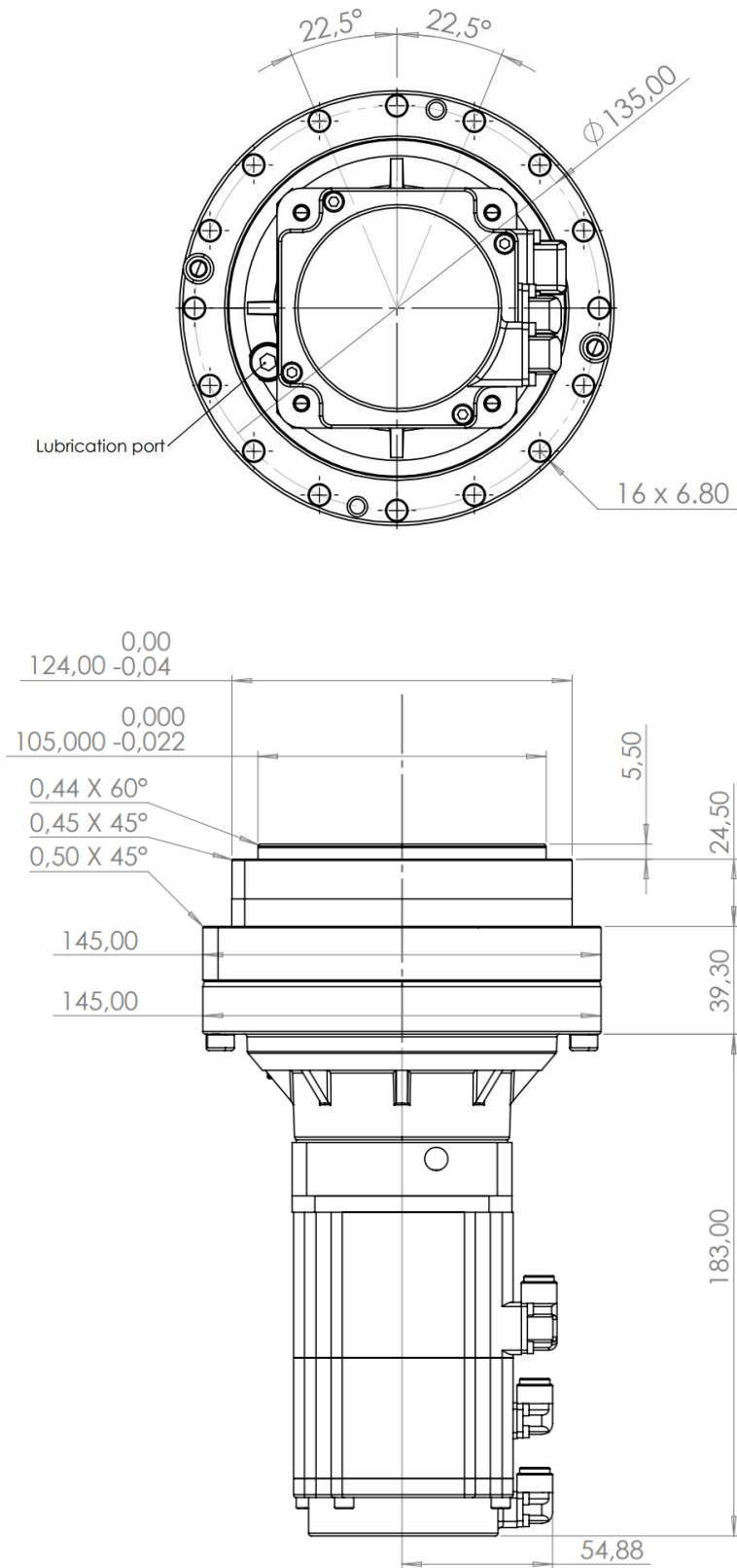

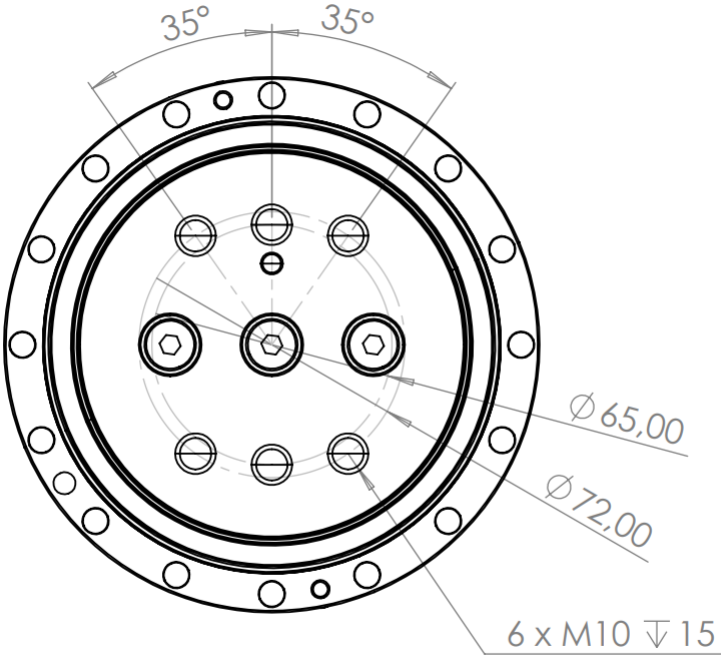



Fig. 1 Basic dimensions of the welding positioner drive module

4. Markings on the machine

 High voltage warning label

 Hot surface warning label

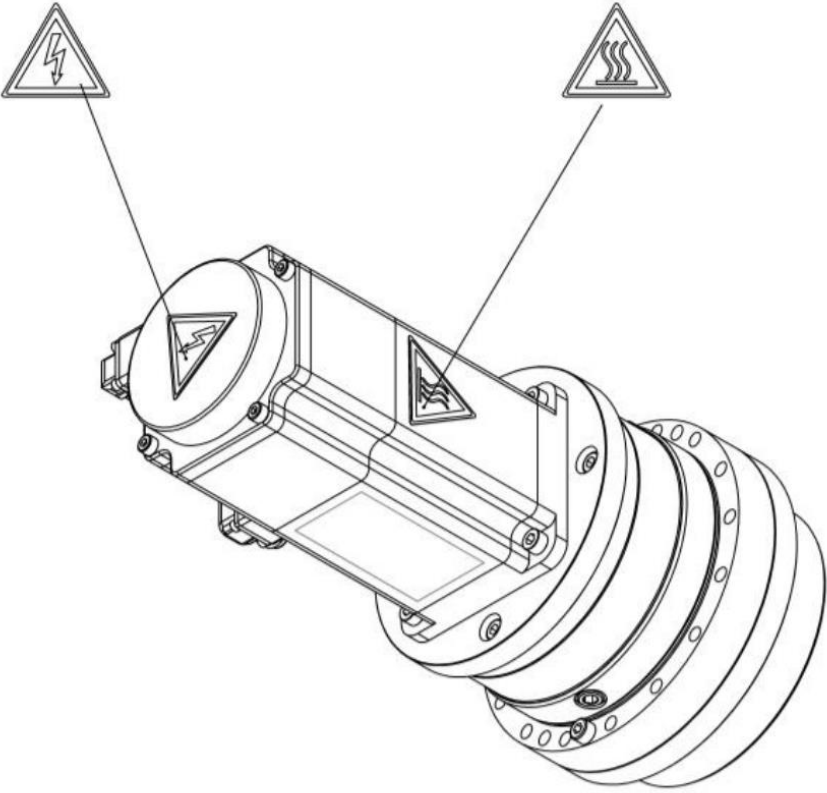

Fig. 2 Warning signs located on the welding positioner drive module

5. Load charts

5.1. Maximum rated load distances

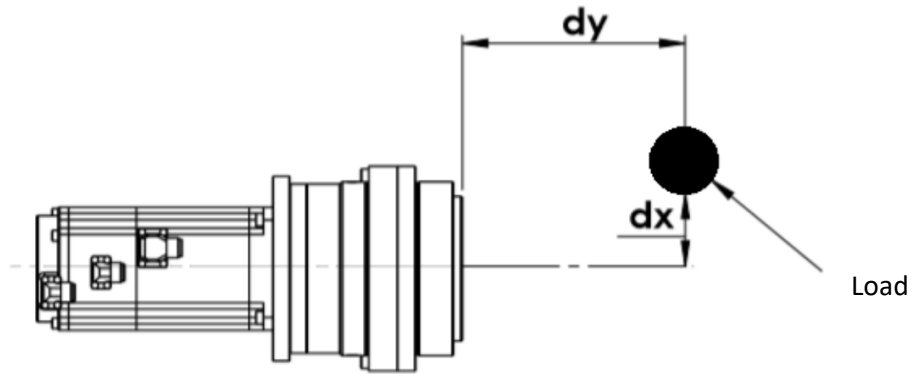

Fig. 3 Nominal rated load position

5.2. Chart of the load relative from the distance from the plate axis

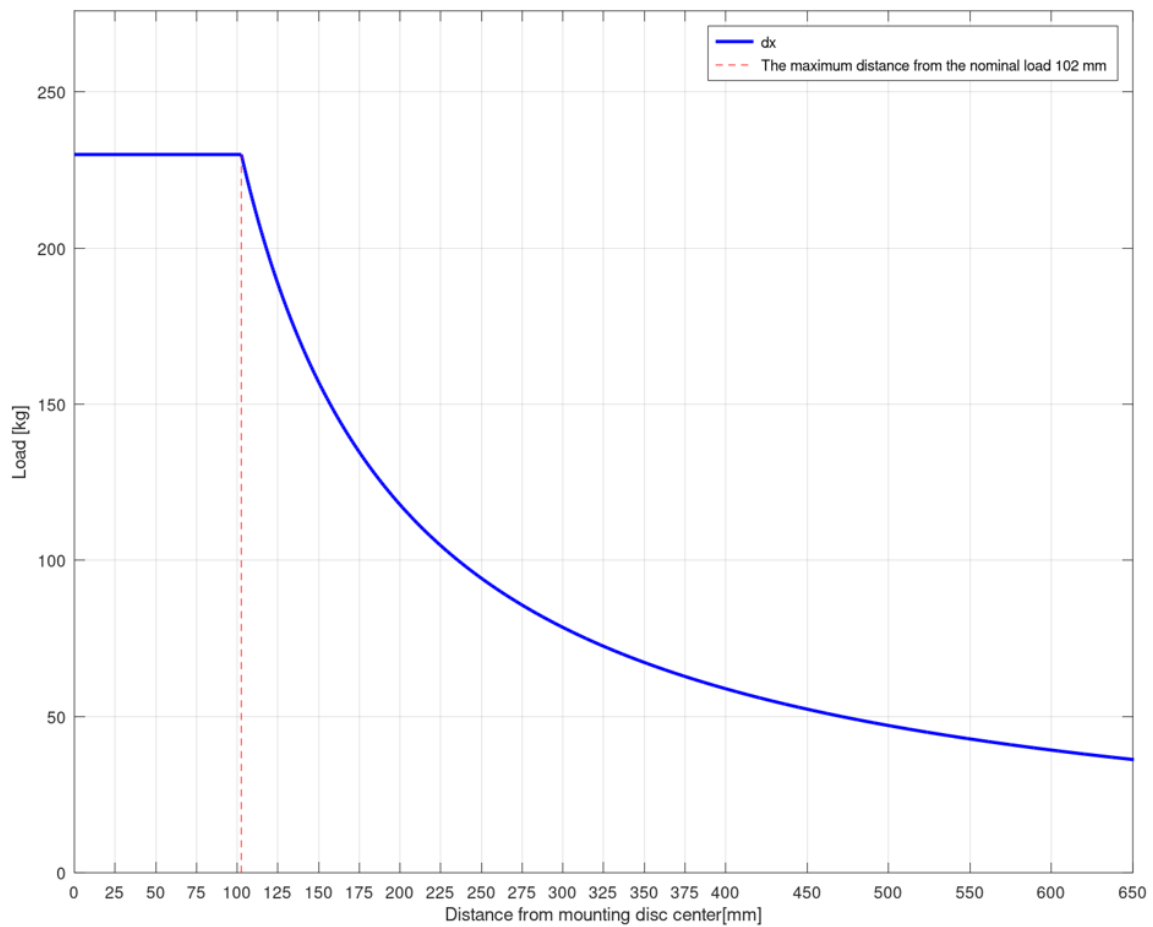

Fig. 4 Drive torque of the axis

6. Basic units of the welding positioner drive module

6.1. Mechanical system

1. Gearbox
2. Kawasaki servodrive: 400W
3. Rating plate

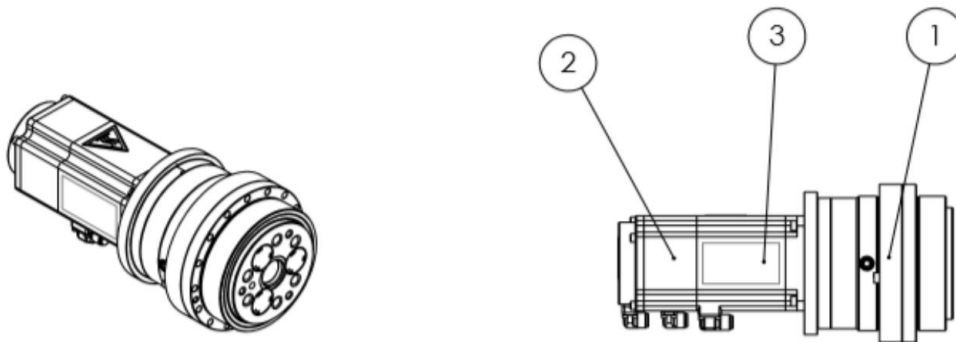

Fig.5 Basic units of the positioner

6.2. Electrical system

The power units consists of:

Axis 1 (Rotation of the plate $-360^{\circ} \div 360^{\circ}$) Kawasaki servo motor 400W and cycloidal transmission.

The axes are controlled as external axes from the robot control system. It is not possible to move the welding positioner drive module without connecting it to the KAWASAKI robot controller. Standard length of electrical wires connecting the servo with the controller is 15m, but usable length is 13m.

7. Assembly and start-up

7.1. Assembly

The PST230SE is assembled, connected, and pre-commissioned by the personnel appropriately prepared for this task. These persons are assigned by the manufacturer. These persons have the knowledge and skills required to safely and correctly assemble the machine. Connection to the mains must be carried out in accordance with the Polish Standards. It is not allowed to carry out the assembly independently; this will result in loss of warranty. During the warranty period, the user may not interfere in the electronic or mechanical components except as set forth in this maintenance documentation. Failure to comply with the above will result in loss of warranty.

The welding positioner drive module must be leveled and fixed to the pedestal/table using foundation bolts, M12 bolts with a strength class of at least 10.9 and positioning pegs. The spacing of the mounting holes fixing the welding positioner drive module to the slab is shown in Figure 1.

7.2. Getting ready for operation

After completing the installation work on the welding positioner drive module:

- Perform all the tasks on connecting the robotic station;
- Set up the tool for the welding positioner drive module;
- Place the part in the tool.

The definition of the external axis is described in the documentation of the External Axis (90210-1292DEC_External_Axis_Addition_Manual_(EOx-Series)).

7.3. Emergency Stop connection

Safety of the JT1 axis is ensured by the robot safety circuits and the circuits must be prepared in accordance with Kawasaki technical documentation.

For proper safety of the JT1 axis of the welding positioner drive module, two PN_CMD and PN_ON signals must be connected to the robot inputs, the signals come from the safety curtain or the safety controller. The signals in a high state after the axes control group (GROUP) change, cause power cut to the servo which is located close to the operator.

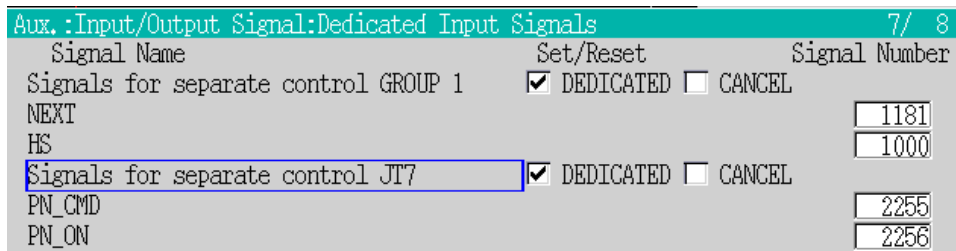

Fig. 7 axis off signal declaration

CAUTION!

When the positioner is supplied, the PN_CMD and PN_ON signals are declared as internal signals. This should be changed when the positioner is integrated in the position.

7.3.1. Cubic-S Option

The Cubic-S option can further control the status of the Kawasaki exterior axis. In order to add the axis monitoring, declare axis 7, 8 or 9 as DEVICE 1, 2 or 3.

No.	Classification	Name	Unit	Value1	Value2	Value3	Value4	Value5	Value6	Value7	Value8	Value9
601	Stop Monitoring	Valid/Invalid in Teach Mode/Fast-forward Check	-	Valid								
32		Robot Joint Definition (1-9)	-	0	0	0	0	0	0	0	0	0
38		Device 1 Joint Definition (1-9)	-	0	0	0	0	0	0	0	0	0
39		Device 2 Joint Definition (1-9)	-	0	0	0	0	0	0	0	0	0
40		Device 3 Joint Definition (1-9)	-	0	0	0	0	0	0	0	0	0

Fig. 8 Stop Monitoring Declaration for auxiliary axis in the Cubic-S option

The definition of the dedicated input for monitoring the status of the auxiliary axis in CUBIC-S is described in **the documentation of the CUBIC-S option (90210-1272DED_Cubic-S_Instruction Manual (E series))**.

7.4. Start-up

To start the welding positioner drive module, connect it to the robot control system.

Connect the 50979-0073L15 with the B marking to the B-JT8 MOTOR in the Kawasaki controller

Connect the 50979-3340L13 with the B marking to the B-JT8 SIGNAL in the Kawasaki controller

Connect the 50979-0073L15 with the C marking to the C-JT8 MOTOR in the Kawasaki controller

Connect the 50979-3340L13 with the C marking to the C-JT8 MOTOR in the Kawasaki controller

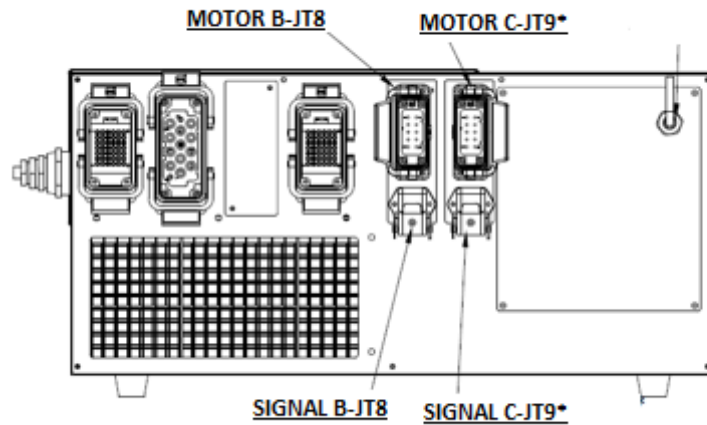

* - connecting the second auxiliary axis wires - a station with two auxiliary Kawasaki axes,

** - only when controlling additional indexing servomotors.

Starting up the welding positioner drive module starts up the robotic station and follows the positioning algorithm.

To move the axis JT7 or JT8 (drives Kawasaki), you should choose the appropriate group. Press the "ALT" key on the Teach Pendant off Monitors under (C) of the screen TP.JT7 or JT8.

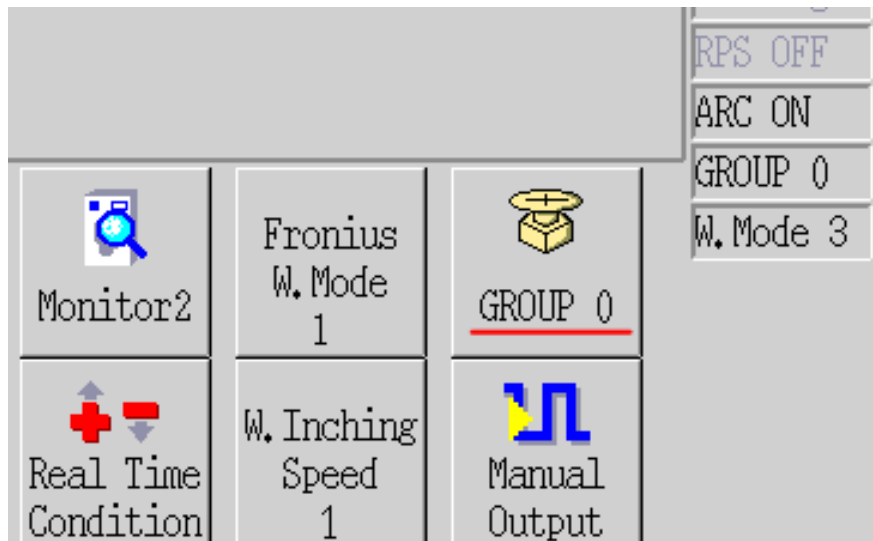

GROUP -1 - no possibility of moving additional axes,

GROUP 0 - the ability to move axes without cooperation,

GROUP 1 - moving the JT7 and JT8 axis in co-operative mode.

Fig. 9 Revision Steering Group axes

Starting the positioner is synonymous with starting the robotic station and follows the algorithm of the station's operation.

7.5. Working and safe use conditions

The PST230SE welding positioner drive module is suitable for indoor use in the following environmental conditions:

- Air free from condensed steam, dust, corrosive or explosive gases;
- Permissible ambient temperature: +5°C ÷ +40°C;
- Maximum temperature of the positioner's plate: 90°C.

When operating the positioner:

- Observe all the safety rules for safe work at a robotic station;
- Get acquainted with possible health or life hazards due to improper operation of the device;
- An employee handling the robotic station with the PST230SE welding positioner drive module must be familiar with the contents of this Operation and Maintenance Manual and the Operation and Maintenance Manual for the industrial robot;
- It is not permitted to carry out maintenance work during the operation of the station
- It is forbidden to leave tools on the housing and servo drives of the positioner.

Detailed health and safety regulations should be developed by the user at the workplace. Observe general health and safety regulations for electrical and mechanical equipment when connecting, starting-up and operating the positioner.

It is not permitted for persons to be present in the operating area of the positioner during the work of the machine (within range of the tilt and working rotation position of the positioner including the tooling) as well as for unauthorized persons to carry out repairs and maintenance.

In addition, the operating crew must know how to attach the tools to the positioner plate and how to place the parts in this equipment.

Secure the robot in the positioner workstation area using fencing and light barriers in accordance with Polish safety standards.

7.6. Maintenance of the welding positioner drive module

Maintenance procedures include measures aiming at reducing wear on parts and components of the mechanical system and ensuring correct positioner operation. Maintenance should be carried out by trained personnel. The service technician authorized to carry out repairs is the manufacturer or a person designated by the manufacturer. The warranty does not cover mechanical damage resulting from improper use of the station.

Before performing any maintenance work, make sure the equipment is disconnected from the mains

7.7. Maintenance schedule

Action \ Period of time	Daily inspection	Monthly inspection	2300 hours	5000 hours or 1 year
Physical damage	<input checked="" type="checkbox"/>		<input checked="" type="checkbox"/>	
Gear backlash and abnormal sounds during operation	<input checked="" type="checkbox"/>		<input checked="" type="checkbox"/>	
* Complement to the copper paste in the ground transfer system		<input checked="" type="checkbox"/>	<input checked="" type="checkbox"/>	
Replenish gear lubrication and bearings				
Check the positioner brakes			<input checked="" type="checkbox"/>	
Refresh transmission lubricants			<input checked="" type="checkbox"/>	
Check the internal wires of the positioner			<input checked="" type="checkbox"/>	
Battery change			<input checked="" type="checkbox"/>	
Check the welding mass clamps				
** Replacement of welding mass clamps				
Checking the tightening torque of the assembly screws			<input checked="" type="checkbox"/>	
Review made by authorized service K-Positioners				<input checked="" type="checkbox"/>

* instruction on performing the activity in item 7.8.

** In case of excessive wear and tear.

8. Storage and transport conditions

8.1. Storage

The PST230SE one-axis positioner should be stored indoors, in rooms free from aggressive corrosive agents. Ambient temperature should range between + 5 ° C ÷ + 40 ° C and humidity should not exceed 80%. The positioner should also be protected against shocks and vibrations.

8.2. Transport

Transport of the positioner should be carried out by clean, dry and covered means of transport, protected against penetration of precipitation into the interior and against exceeding the temperatures of + 50 ° C and -25 ° C. At the same time the positioner must be protected against sliding.

9. Safety information and residual risk

The PST230SE welding positioner drive module has been designed and built for precise positioning of objects attached to it in one axis, depending on the used version of the device. It is a prerequisite for the safe use of the device described above that the maximum permissible load shown in this manual is not exceeded.

9.1. Danger due to mechanical construction:

9.1.1. Crashing and cut-offs

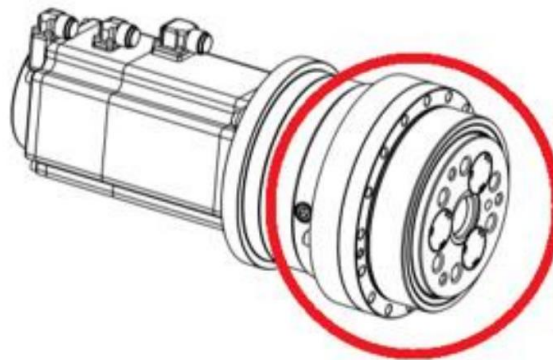

Fig. 12 Areas with the risk of crashing

There is a risk of crashing, cutting fingers or other parts of the body in the marked areas. Do not leave or put any tools or parts of the body or animals in these areas.

It is forbidden to stay in the work zone while the welding positioner drive module is in operation.

9.2. Dangers due to the electrical system

After connecting the welding positioner drive module to the mains, it is forbidden to connect and/or disconnect the wiring of the device; these actions may result in an electric shock.

10. Warranty conditions



Warranty covers only defects arising from causes inherent in the sold product. The manufacturer's warranty covers 12 months. The basic principle of the maintenance of warranty is to use a table with the timing of the steps preservatives (p. 11) and use the device as intended and technical parameters.

11. Notes

Appendix 1.

Parts of the welding positioner drive module must be ordered from the ASTOR company. Contact data available at: www.astor.com.pl/en/contact-us/. In order to improve order handling, please specify the welding positioner drive module model and the part name along with the code.

Spare Parts List:

Name	Image	Product code	Quantity [pcs]
Kawasaki Robotics Servo drive 400W		50601-1119B	1
Cycloidal transmission JT1		RVM-020E	1

12. **Manufacturer's data**



ASTOR Sp. z o.o.

29, Smoleńsk St., 31-112 Kraków, Poland

Phone number: +48 (12) 428 63 00

<https://www.astor.com.pl/en>

e-mail: info@astor.com.pl

NIP: 676 01 05 127

